



**DIODES, MICROWAVE, SILICON,**

**MULTIPLIER VARACTOR**

**BASED ON TYPES DH252, DH256, DH267, DH292**

**AND DH294**

**ESCC Detail Specification No. 5512/016**

Issue 5	November 2014
---------	---------------



### **LEGAL DISCLAIMER AND COPYRIGHT**

European Space Agency, Copyright © 2013. All rights reserved.

The European Space Agency disclaims any liability or responsibility, to any person or entity, with respect to any loss or damage caused, or alleged to be caused, directly or indirectly by the use and application of this ESCC publication.

This publication, without prior permission of the European Space Agency and provided it is not used for a commercial purpose, may be:

- copied in whole, in any medium, without alteration or modification.
- copied in part, in any medium, provided that the ESCC document identification, comprising the ESCC symbol, document number and document issue, is removed.

**DOCUMENTATION CHANGE NOTICE**

(Refer to <https://escies.org> for ESCC DCR content)

DCR No.	CHANGE DESCRIPTION
863	Specification upissued to incorporate editorial changes per DCR.

**TABLE OF CONTENTS**

1	GENERAL	6
1.1	SCOPE	6
1.2	TYPE VARIANTS	6
1.3	MAXIMUM RATINGS	6
1.4	PARAMETER DERATING INFORMATION	6
1.5	PHYSICAL DIMENSIONS	6
1.6	FUNCTIONAL DIAGRAM	6
1.7	HANDLING PRECAUTIONS	6
2	APPLICABLE DOCUMENTS	6
3	TERMS, DEFINITIONS, ABBREVIATIONS, SYMBOLS AND UNITS	7
4	REQUIREMENTS	18
4.1	GENERAL	18
4.2	DEVIATIONS FROM GENERIC SPECIFICATION	18
4.2.1	Deviations from Production Control	18
4.2.2	Deviations from Final Production Tests (Chart II(b))	18
4.2.3	Deviations from Burn-in and Electrical Measurements (Chart III(a))	18
4.2.4	Deviations from Qualification Tests (Chart IV)	18
4.2.5	Deviations from Lot Acceptance Tests (Chart V)	19
4.3	MECHANICAL AND ENVIRONMENTAL REQUIREMENTS	19
4.3.1	Dimension Check	19
4.3.2	Weight	19
4.3.3	Terminal Strength	19
4.3.4	Bond Strength	19
4.3.5	Die Shear	19
4.3.6	High Temperature Stabilisation Bake	19
4.4	MATERIALS AND FINISHES	19
4.4.1	Case	20
4.4.2	Lead Materials and Finish	20
4.5	MARKING	20
4.5.1	General	20
4.5.2	Cathode Identification	20
4.5.3	The ESCC Component Number	20
4.5.4	Traceability Information	20
4.6	ELECTRICAL MEASUREMENTS	21
4.6.1	Electrical Measurements at Room Temperature	21

4.6.2	Electrical Measurements at High and Low Temperatures	21
4.6.3	Circuits for Electrical Measurements	21
4.7	BURN-IN TESTS	21
4.7.1	Parameter Drift Values	21
4.7.2	Conditions for High Temperature Reverse Bias Burn-in	21
4.7.3	Conditions for Power Burn-in	21
4.7.4	Electrical Circuits for High Temperature Reverse Bias and Power Burn-in	21
4.8	ENVIRONMENTAL AND ENDURANCE TESTS (CHARTS IV AND V OF ESCC GENERIC SPECIFICATION NO. 5010)	27
4.8.1	Electrical Measurements on Completion of Environmental Tests	27
4.8.2	Electrical Measurements at Intermediate Points and on Completion of Endurance Tests	27
4.8.3	Conditions for Operating Life Tests (Part of Endurance Testing)	27
4.8.4	Electrical Circuits for Operating Life Tests	27
4.9	TOTAL DOSE IRRADIATION TESTING	27
4.10	SPECIAL TESTING	27
	APPENDIX 'A'	28

## 1 GENERAL

### 1.1 SCOPE

This specification details the ratings, physical and electrical characteristics, test and inspection data for a Diode, Microwave, Silicon, Multiplier Varactor, based on Types DH252, DH256, DH267, DH292 and DH294. It shall be read in conjunction with ESCC Generic Specification No. 5010, the requirements of which are supplemented herein.

### 1.2 TYPE VARIANTS

Variants of the basic diodes specified herein, which are also covered by this specification are given in Table 1(a).

### 1.3 MAXIMUM RATINGS

The maximum ratings, which shall not be exceeded at any time during use or storage, applicable to the diodes specified herein, are as scheduled in Table 1(b).

### 1.4 PARAMETER DERATING INFORMATION

The derating information applicable to the diodes specified herein is shown in Figure 1.

### 1.5 PHYSICAL DIMENSIONS

The physical dimensions of the diodes specified herein are shown in Figure 2.

### 1.6 FUNCTIONAL DIAGRAM

The functional diagram, showing lead identification, of the diodes specified herein, is shown in Figure 3.

### 1.7 HANDLING PRECAUTIONS

These devices are susceptible to damage by electrostatic discharge. Therefore, suitable precautions shall be employed for protection during all phases of manufacture, testing, packaging, shipment and any handling.

These components are Categorised as Class 2 with a Minimum Critical Path Failure Voltage of 1550V.

## 2 APPLICABLE DOCUMENTS

The following documents form part of this specification and shall be read in conjunction with it:

- (a) ESCC Generic Specification No. 5010 for Discrete Microwave Semiconductor Components.
- (b) MIL-STD-750, Test Methods for Semiconductor Devices.

**3 TERMS, DEFINITIONS, ABBREVIATIONS, SYMBOLS AND UNITS**

For the purpose of this specification, the terms, definitions, abbreviations, symbols and units specified in ESCC Basic Specification No. 21300 shall apply. In addition the following symbols are used:

- $C_T$  = Total Capacitance
- $\tau_L$  = Minority Carrier Lifetime
- $t_{SO}$  = Snap off Time

**TABLE 1(a) – TYPE VARIANTS**

(1) Variant	(2) Based On Type	(3) Figure	(4) Total Capacitance $C_T$ (pF) (Note 1)		(5) Output Power $P_{out}$ (W)	(6) Output Frequency $f_0$ (GHz)	(7) Body-Lid And Lead Material And Finish
			Min	Max			
10	DH267	2(a)	0.3	0.4	0.2	10-25	D7-E2
11		2(b)					D7
12		2(c)					D7-E2
13		2(d)					
14		2(e)					
15		2(f)					
16		2(g)					0.4
20	DH292	2(a)	0.3	0.6	0.6	8-16	D7-E2
21		2(b)					D7
22		2(c)					D7-E2
23		2(d)					
24		2(e)					
25		2(f)					
26		2(g)					0.4
30	DH256	2(a)	0.6	1.2	2.0	5-12	D7-E2
31		2(b)					D7
32		2(c)					D7-E2
33		2(d)					
34		2(e)					
35		2(f)					
36		2(g)					0.7

(1) Variant	(2) Based On Type	(3) Figure	(4) Total Capacitance $C_T$ (pF) (Note 1)		(5) Output Power $P_{out}$ (W)	(6) Output Frequency $f_0$ (GHz)	(7) Body-Lid And Lead Material And Finish
			Min	Max			
40	DH252	2(a)	1	2.1	3.0	2-8	D7-E2
41		2(b)					D7
42		2(c)					D7-E2
43		2(d)					
44		2(e)					
45		2(f)	A7-D7				
46		2(g)		1.1			2.2
50	DH294	2(a)	4.1	7.1	0.5	0.2-2	D7-E2
51		2(b)					D7
52		2(c)					D7-E2
53		2(d)					
54		2(e)					
55		2(f)	A7-D7				
56		2(g)		4.2			7.2

**NOTES**

1.  $V_R = -6.0V$ ,  $f = 1.0MHz$ .



**TABLE 1(b) - MAXIMUM RATINGS**

No.	Characteristic	Symbol	Maximum Ratings	Unit	Remarks
1	DC Reverse Voltage Variants 10 to 16 Variants 20 to 26 Variants 30 to 36 Variants 40 to 46 Variants 50 to 56	$V_R$	-15 -20 -30 -40 -45	V	-
2	DC Forward Current (Continuous) Variants 10 to 15, 20 to 25 and 30 to 35 Variants 40 to 45 and 50 to 55 Variants 16 and 26 Variants 36, 46 and 56	$I_F$	250 500 600 1000	mA	Note 1
3	RF Power Dissipation Variants 10 to 15, 20 to 25, 30 to 35 and 40 to 45 Variants 50 to 55 Variants 16 and 26 Variants 36, 46 and 56	$P_{tot}$	0.5 0.6 0.75 1.25	W	Note 1
4	Operating Temperature Range	$T_{op}$	-55 to +150	°C	$T_{case}$ (Infinite Heat Sink)
5	Storage Temperature Range	$T_{stg}$	-65 to +175	°C	-
6	Soldering Temperature	$T_{sol}$	+230	°C	Note 2

**NOTES**

1. At  $T_{amb} = +75^\circ\text{C}$ . For derating at  $T_{amb} > +75^\circ\text{C}$ , see Figure 1.
2. Duration 5 seconds maximum and the same termination shall not be resoldered until 3 minutes have elapsed.

**FIGURE 1 - PARAMETER DERATING INFORMATION**

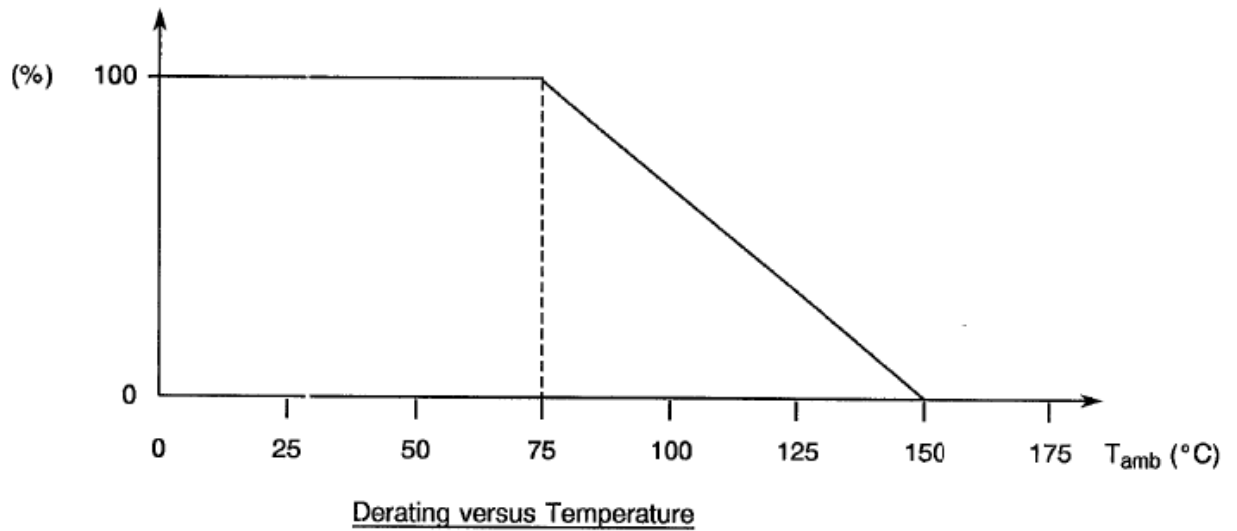

**NOTES**

1. Thermal Resistance  $R_{TH(J-C)}$ :
  - Variants 10 to 15, 20 to 25, 30 to 35 and 40 to 45: 150°C/W
  - Variants 50 to 55: 125°C/W
  - Variants 16 and 26: 100°C/W
  - Variants 36, 46 and 56: 60°C/W

**FIGURE 2 – PHYSICAL DIMENSIONS**

**FIGURE 2(a) - VARIANTS 10, 20, 30, 40, 50**

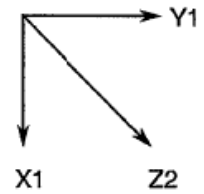
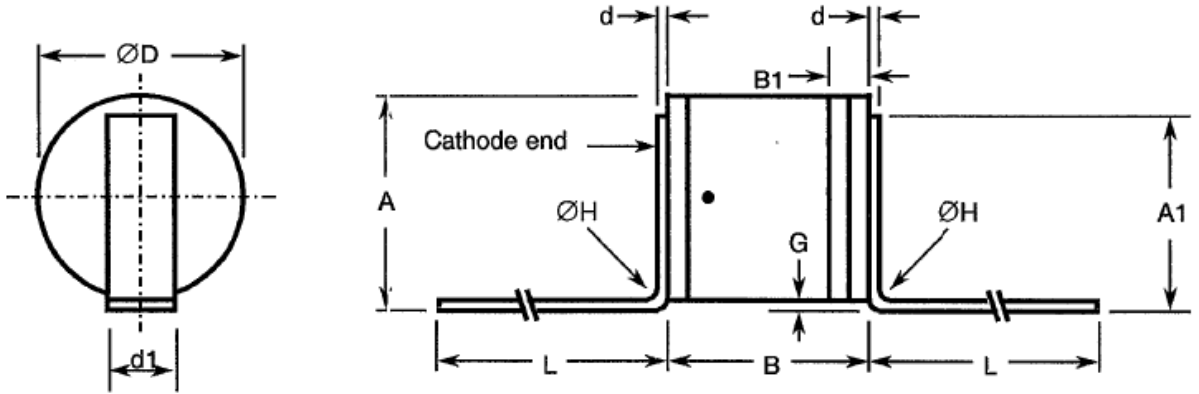

Symbol	Millimetres	
	Min	Max
A	1.3	1.9
A1	1.22	1.82
B	0.95	1.35
B1	0.23	0.33
d	0.06	0.1
d1	0.55	0.65
$\varnothing D$	1.07	1.47
G	0.1	0.5
$\varnothing H$	0.1	0.5
L	2.5	-

FIGURE 2(b) - VARIANTS 11, 21, 31, 41, 51

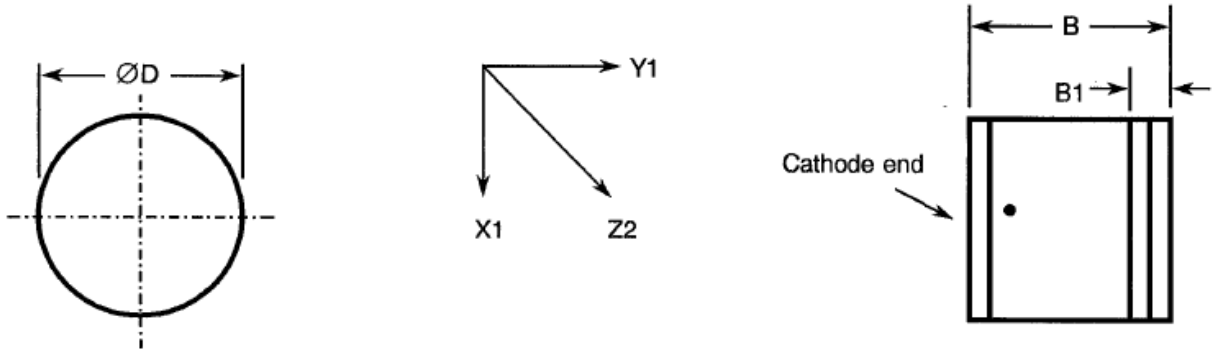

Symbol	Millimetres	
	Min	Max
B	0.95	1.35
B1	0.23	0.33
$\varnothing D$	1.07	1.47

FIGURE 2(c) – VARIANTS 12, 22, 32, 42, 52

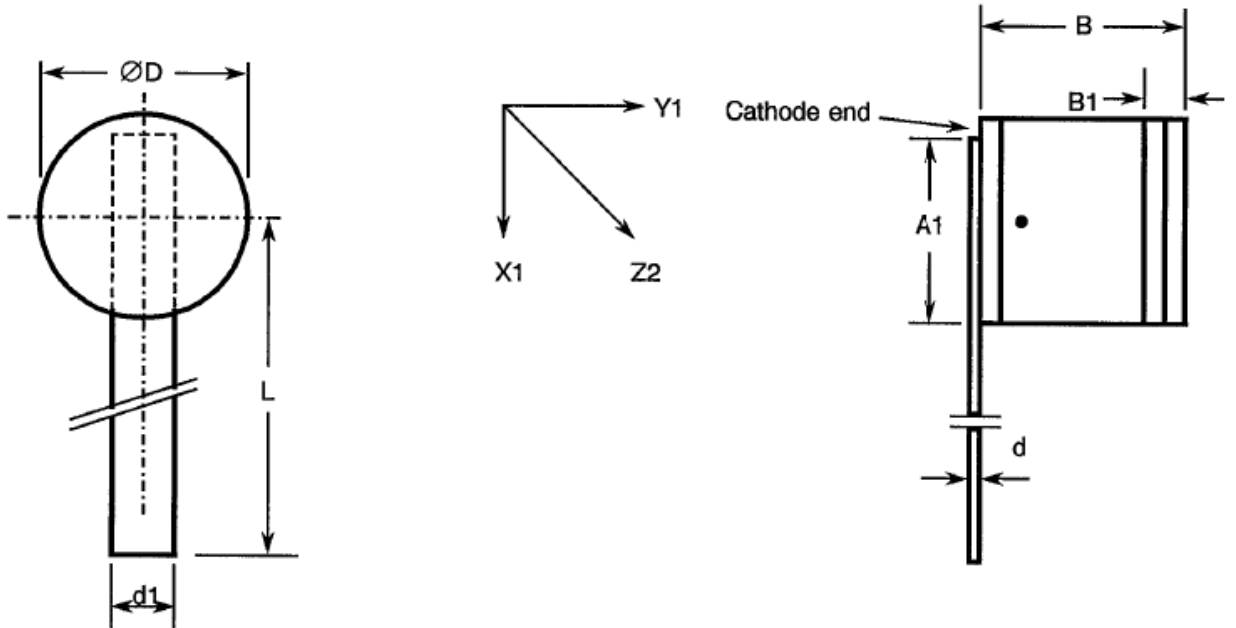

Symbol	Millimetres	
	Min	Max
A1	0.99	1.39
B	0.95	1.35
B1	0.23	0.33
d	0.06	0.1
d1	0.55	0.65
$\varnothing D$	1.07	1.47
L	5	-

FIGURE 2(d) – VARIANTS 13, 23, 33, 43, 53

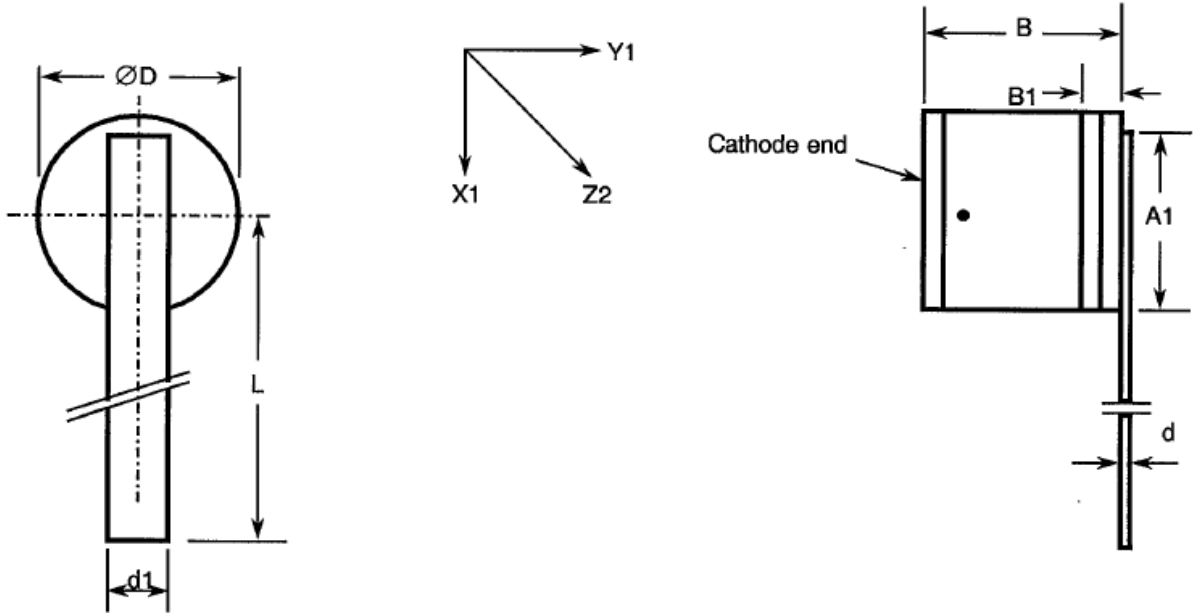

Symbol	Millimetres	
	Min	Max
A1	0.99	1.39
B	0.95	1.35
B1	0.23	0.33
d	0.06	0.1
d1	0.55	0.65
$\varnothing D$	1.07	1.47
L	5	-

FIGURE 2(e) – VARIANTS 14, 24, 34, 44, 54

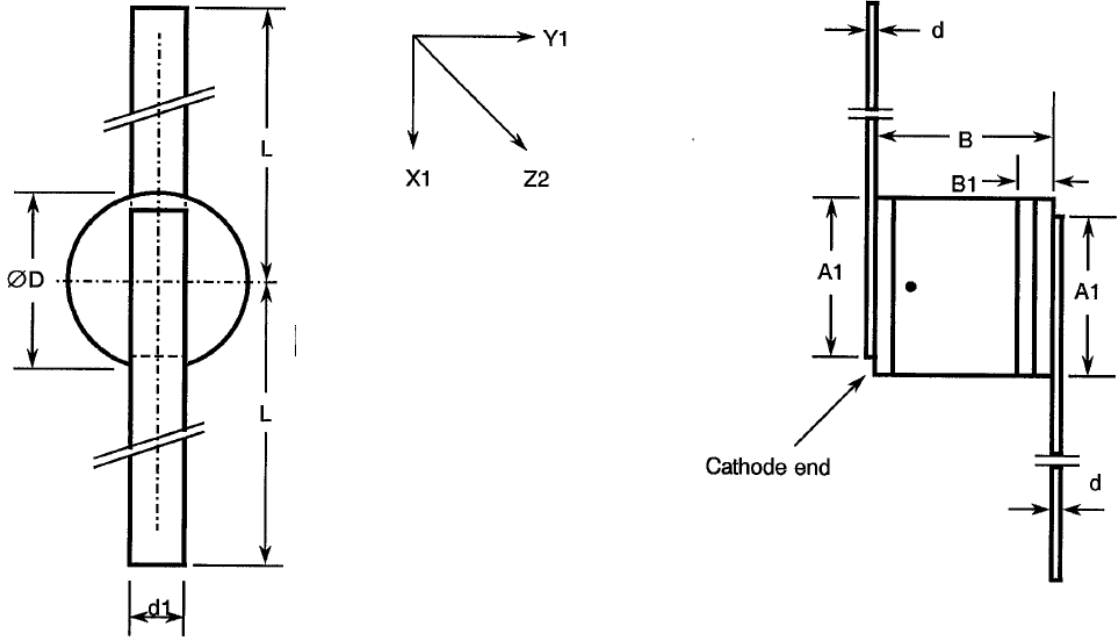

Symbol	Millimetres	
	Min	Max
A1	0.99	1.39
B	0.95	1.35
B1	0.23	0.33
d	0.06	0.1
d1	0.55	0.65
$\varnothing D$	1.07	1.47
L	5	-

FIGURE 2(f) – VARIANTS 15, 25, 35, 45, 55

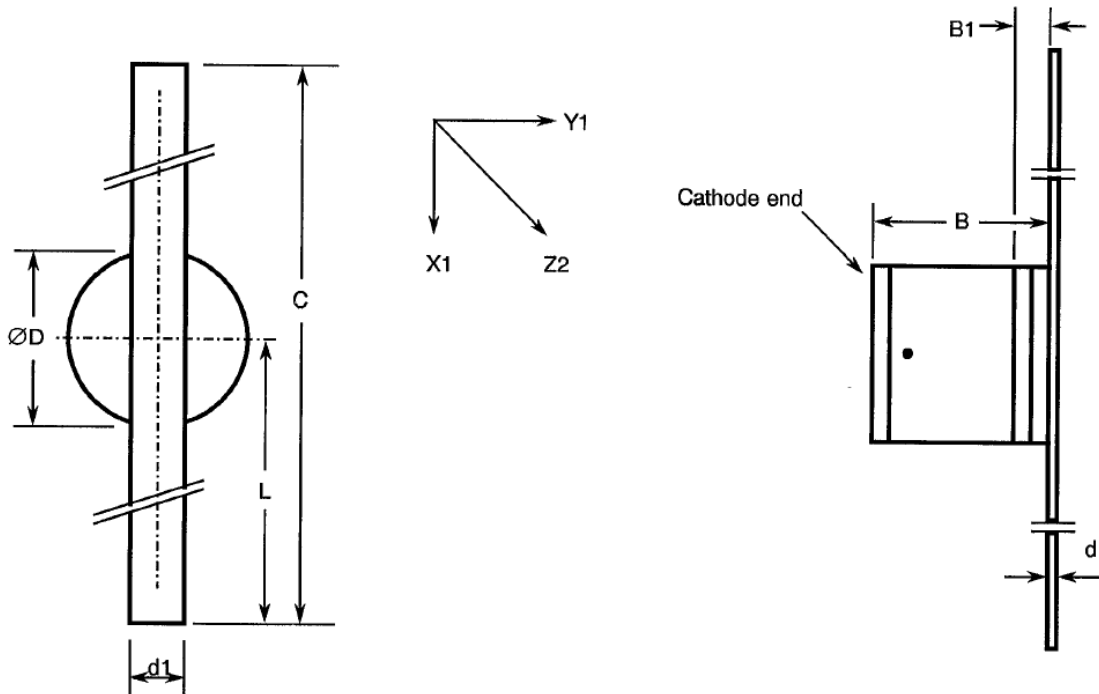

Symbol	Millimetres	
	Min	Max
B	0.95	1.35
B1	0.23	0.33
C	10	10.4
d	0.06	0.1
d1	0.55	0.65
$\varnothing D$	1.07	1.47
L	5	-



FIGURE 2(g) – VARIANTS 16, 26, 36, 46, 56

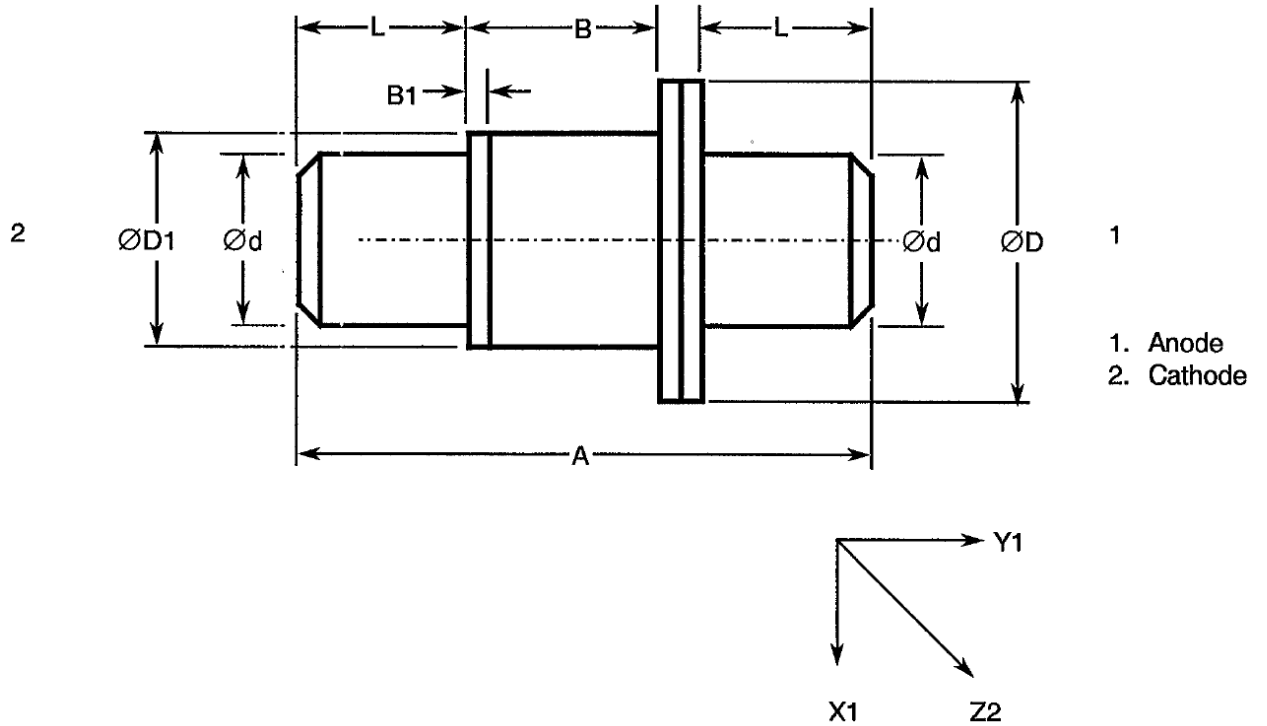

Symbol	Millimetres	
	Min	Max
A	5.2	5.72
B	1.75	1.85
B1	0.15	0.25
$\varnothing d$	1.52	1.63
$\varnothing D$	3	3.23
$\varnothing D1$	1.95	2.11
L	1.52	1.63

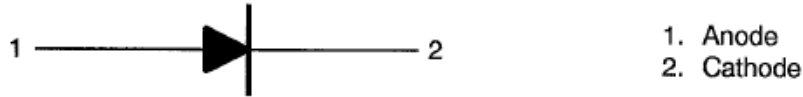
**FIGURE 3 – FUNCTIONAL DIAGRAM****NOTES**

1. The cathode end shall be marked with a black dot. The marking will not be on the cathode connection but adjacent to it except for the case in Figure 2(g).

**4 REQUIREMENTS****4.1 GENERAL**

The complete requirements for procurement of the diodes specified herein are stated in this specification and ESCC Generic Specification No. 5010 for discrete Microwave Semiconductor Components. Deviations from the Generic Specification, applicable to this specification only, are listed in Para. 4.2.

Deviations from the applicable Generic Specification and this Detail Specification, formally agreed with specific Manufacturers on the basis that the alternative requirements are equivalent to the ESCC requirements and do not affect the components' reliability, are listed in the appendices attached to this specification.

**4.2 DEVIATIONS FROM GENERIC SPECIFICATION****4.2.1 Deviations from Production Control**

- (a) Para. 5.3, Wafer Lot Acceptance: Minority Carrier Lifetime ( $\tau_L$ ) and Snap Off Time ( $t_{SO}$ ) shall be performed on wafer acceptance best parts. 27 die on wafer for  $\tau_L$  and 20 packaged diodes for  $t_{SO}$ .

**4.2.2 Deviations from Final Production Tests (Chart II(b))**

None.

**4.2.3 Deviations from Burn-in and Electrical Measurements (Chart III(a))**

None.

**4.2.4 Deviations from Qualification Tests (Chart IV)**

- (a) Para. 9.13, Shock Test: Shall not be performed.
- (b) Para. 9.14, Vibration: Shall not be performed.
- (c) Para. 9.15, Constant Acceleration: Shall not be performed.
- (d) Para. 9.19, Terminal Strength: Shall not be performed for Variants 11, 16, 21, 26, 31, 36, 41, 46, 51 and 56.
- (e) Para. 9.23, Special Testing: Shall not be performed.

#### 4.2.5 Deviations from Lot Acceptance Tests (Chart V)

- (a) Para. 9.13, Shock Test: Shall not be performed.
- (b) Para. 9.14, Vibration: Shall not be performed.
- (c) Para. 9.15, Constant Acceleration: Shall not be performed.
- (d) Para. 9.19, Terminal Strength: Shall not be performed for Variants 11, 16, 21, 26, 31, 36, 41, 46, 51 and 56.
- (e) Para. 9.23, Special Testing: Shall not be performed.

### 4.3 MECHANICAL AND ENVIRONMENTAL REQUIREMENTS

#### 4.3.1 Dimension Check

The dimensions of the diodes specified herein shall be checked. They shall conform to those shown in Figure 2.

#### 4.3.2 Weight

The maximum weight of the diodes specified herein shall be as follows:

- Variants 10 to 15, 20 to 25, 30 to 35, 40 to 45 and 50 to 55: 0.02g.
- Variants 16, 26, 36, 46 and 56: 0.15g.

#### 4.3.3 Terminal Strength

The requirements for terminal strength testing are specified in Section 9 of ESCC Generic Specification No. 5010. The test conditions shall be as follows:

- (a) Condition: 'A' (Tension) Variants 10, 12 to 15, 20, 22 to 25, 30, 32 to 35, 40, 42 to 45, 50 and 52 to 55:
  - Force: 1.25N
  - Duration: 10 seconds.

#### 4.3.4 Bond Strength

The requirements for bond strength are specified in Section 9 of ESCC Generic Specification No. 5010. The test conditions shall be as follows:

- (a) Condition: 'A' (tension).
- (b) Separating Force: 0.03N minimum.

#### 4.3.5 Die Shear

The requirements for die shear are specified in Section 9 of ESCC Generic Specification No. 5010. The test conditions shall be as follows:-

- (a) Semiconductor material remaining: 50% minimum.

#### 4.3.6 High Temperature Stabilisation Bake

The requirements for high temperature stabilisation bake are specified in Section 9 of ESCC Generic Specification No. 5010. The temperature to be applied shall be +175 (+0 -3)°C.

### 4.4 MATERIALS AND FINISHES

The materials and finishes shall be as specified herein. Where a definite material is not specified, a material which will enable the diodes specified herein to meet the performance requirements of this specification shall be used. Acceptance or approval of any constituent material shall not guarantee acceptance of the finished product.

#### 4.4.1 Case

The case shall be hermetically sealed and have a ceramic body. The lid shall be welded or preform soldered.

#### 4.4.2 Lead Materials and Finish

- (a) For Variants 10 to 15, 20 to 25, 30 to 35, 40 to 45 and 50 to 55, the body material shall be Type 'D' with Type '7' finish and the lid material shall be Type 'E' with Type '2' finish, in accordance with the requirements of ESCC Basic Specification No. 23500.
- (b) For Variants 16, 26, 36, 46 and 56, the body material shall be Type 'A' with Type '7' finish and the lid material shall be Type 'D' with Type '7' finish, in accordance with the requirements of ESCC Basic specification No. 23500.

### 4.5 MARKING

#### 4.5.1 General

The marking of components delivered to this specification shall be in accordance with the requirements of ESCC Basic Specification No. 21700 and the following paragraphs. When the component is too small to accommodate all of the marking specified, as much as space permits shall be marked and the marking information, in full, shall accompany the component in its primary package.

The information to be marked and the order of precedence, shall be as follows:-

- (a) Cathode Identification.
- (b) The ESCC Component Number.
- (c) Traceability Information.

#### 4.5.2 Cathode Identification

Cathode identification shall be as shown in Figures 2 and 3 of this specification.

#### 4.5.3 The ESCC Component Number

Each component shall bear the ESCC Component Number which shall be constituted and marked as follows:

Example: 551201610BF

- Detail Specification Number: 5512016
- Type Variant (see Table 1(a)): 10
- Testing Level (B or C, as applicable): B
- Total Dose Irradiation Level (if applicable): F

The Total Dose Irradiation Level designation shall be added for those devices for which a sample has been successfully tested to the level in question. For these devices, a code letter shall be added in accordance with the requirements of ESCC Basic Specification No. 22900.

#### 4.5.4 Traceability Information

Each component shall be marked in respect of traceability information as defined in ESCC Basic Specification No. 21700.

#### 4.6 ELECTRICAL MEASUREMENTS

##### 4.6.1 Electrical Measurements at Room Temperature

The parameters to be measured at room temperature are scheduled in Table 2. Unless otherwise specified, the measurements shall be performed at  $T_{amb} = +22 \pm 3^{\circ}\text{C}$ .

##### 4.6.2 Electrical Measurements at High and Low Temperatures

The parameters to be measured at high and low temperatures are scheduled in Table 3. Unless otherwise specified, the measurements shall be performed at  $T_{amb} = +150 (+0 -3)^{\circ}\text{C}$ .

##### 4.6.3 Circuits for Electrical Measurements

Circuits for use in performing electrical measurements listed in Table 2 of this specification are shown in Figure 4.

#### 4.7 BURN-IN TESTS

Burn-in shall be Category 2 of Chart III(a) of ESCC Generic Specification No. 5010.

##### 4.7.1 Parameter Drift Values

The parameter drift values applicable to burn-in are specified in Table 4 of this specification. Unless otherwise stated, the measurements shall be performed at  $T_{amb} = +22 \pm 3^{\circ}\text{C}$ . The parameter drift values ( $\Delta$ ) applicable to the scheduled parameters shall not be exceeded. In addition to these drift value requirements for a given parameter, the appropriate limit value specified in Table 2 shall not be exceeded.

##### 4.7.2 Conditions for High Temperature Reverse Bias Burn-in

The requirements for the high temperature reverse bias burn-in are specified in Section 9 of ESCC Generic Specification No. 5010. The conditions for high temperature reverse bias burn-in shall be as specified in Table 5(a) of this specification.

##### 4.7.3 Conditions for Power Burn-in

The requirements for power burn-in are specified in Section 9 of ESCC Generic Specification No. 5010. The conditions for power burn-in shall be as specified in Table 5(b) of this specification.

##### 4.7.4 Electrical Circuits for High Temperature Reverse Bias and Power Burn-in

Circuits for use in performing the H.T.R.B and power burn-in tests are shown in Figures 5(a) and 5(b) of this specification.

**TABLE 2 – ELECTRICAL MEASUREMENTS AT ROOM TEMPERATURE – DC PARAMETERS**

No.	Characteristics	Symbol	MIL-STD-750 Test Method	Test Conditions	Limits		Unit
					Min.	Max.	
1	Breakdown Voltage	$V_{BR}$	4021	$I_R = 10\mu A$ Variants 10 to 16 Variants 20 to 26 Variants 30 to 36 Variants 40 to 46 Variants 50 to 56	-15 -20 -30 -40 -45	- - - - -70	V
2	Reverse Current	$I_R$	4016	$V_R = -10V$	-	20	nA
3	Forward Voltage	$V_F$	4011	$I_F = 10mA$	-	1.1	V

**TABLE 2 – ELECTRICAL MEASUREMENTS AT ROOM TEMPERATURE – AC PARAMETERS**

No.	Characteristics	Symbol	MIL-STD-750 Test Method	Test Fig.	Test Conditions	Limits		Unit
						Min.	Max.	
4	Total Capacitance	$C_T$	4001	-	$V_R = -6.0V$ $f = 1.0MHz$	Note 1		pF
5	Minority Carrier Lifetime Note 2	$\tau_L$	-	4(a)	$I_F = 10mA$ $I_R = 6mA$ Variants 10 to 16 Variants 20 to 26 Variants 30 to 36 Variants 40 to 46 Variants 50 to 56	6 10 20 35 125	- - - - -	ns
6	Snap Off Time Note 2	$t_{SO}$	-	4(b)	$I_F = 10mA$ $V_R = 10V$ Variants 10 to 16 Variants 20 to 26 Variants 30 to 36 Variants 40 to 46 Variants 50 to 56	- - - - -	60 75 120 200 400	ps

**NOTES**

1. See Column 4 of Table 1(a).
2. Only on wafer acceptance test parts.

**TABLE 3 - ELECTRICAL MEASUREMENTS AT HIGH AND LOW TEMPERATURES**

No.	Characteristics	Symbol	MIL-STD-750 Test Method	Test Conditions	Limits		Unit
					Min.	Max.	
2	Reverse Current 2	$I_R$	4016	$V_R = -10V$	-	1	$\mu A$

**TABLE 4 - PARAMETER DRIFT VALUES**

No.	Characteristics	Symbol	Spec. And/Or Test Method	Test Conditions	Change Limits ( $\Delta$ )	Unit
2	Reverse Current	$I_R$	As per Table 2	As per Table 2	$\pm 5$ (1) or (2) $\pm 100$ (1)	nA %
3	Forward Voltage	$V_F$	As per Table 2	As per Table 2	$\pm 5$ (1)	%
4	Total Capacitance	$C_T$	As per Table 2	As per Table 2	$\pm 5$ (1) (3)	%

**NOTES**

- $\Delta 1 = \Delta 2$ .
- Whichever is the greater, referred to the initial measurement.
- Rounded upwards to nearest 0.01pF value. If  $C_T \leq 0.50pF$  then  $\Delta = \pm 10\%$ .

**FIGURE 4 – CIRCUITS FOR ELECTRICAL MEASUREMENTS**

**FIGURE 4(a) - CIRCUIT FOR MEASUREMENT OF MINORITY CARRIER LIFETIME**

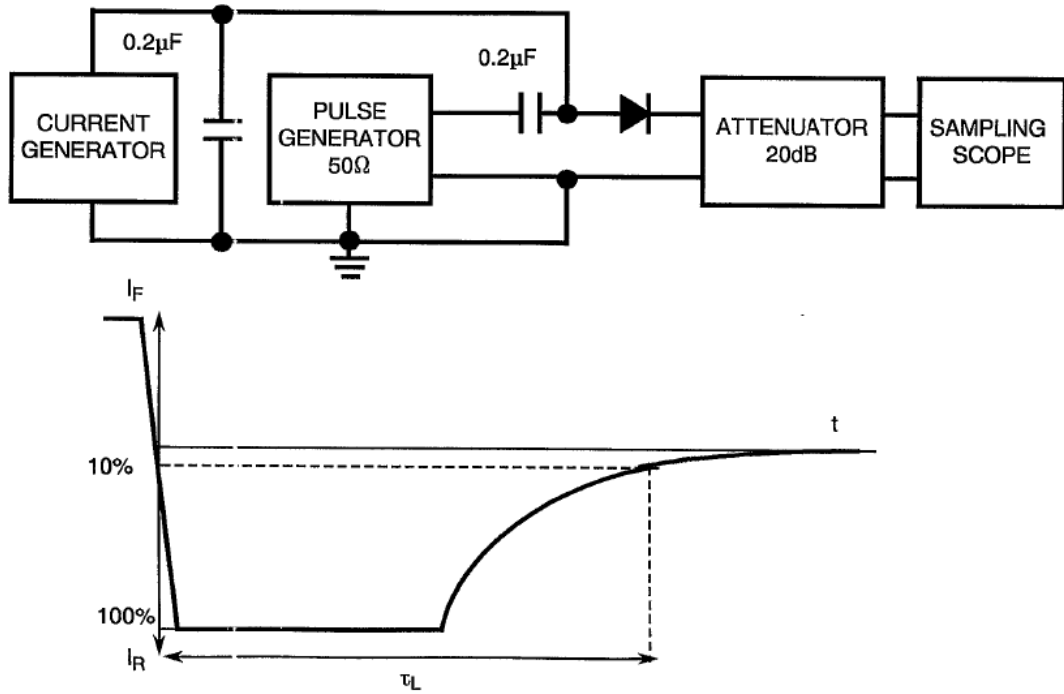



FIGURE 4(b)- CIRCUIT FOR MEASUREMENT OF SNAP-OFF TIME

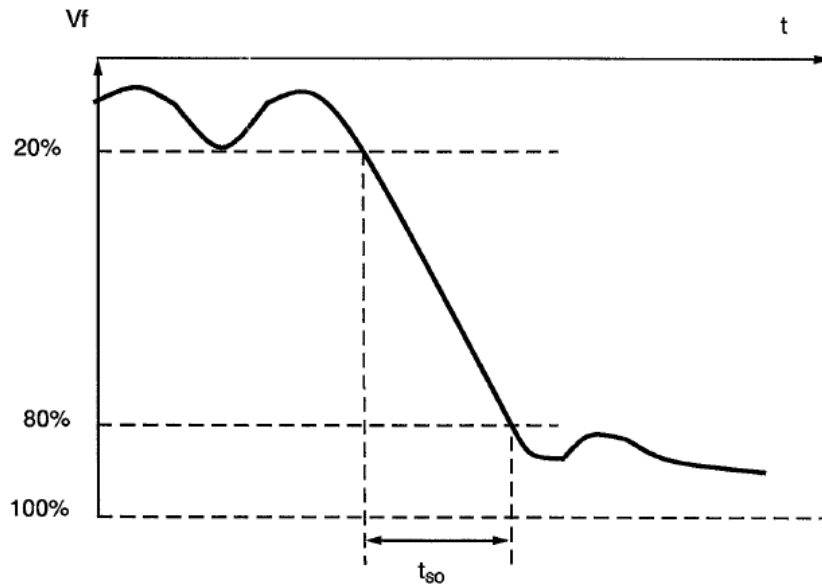
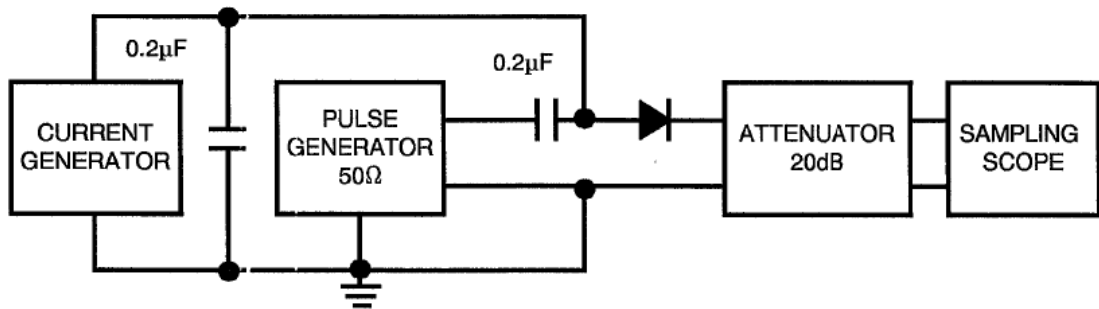

TABLE 5(a) - CONDITIONS FOR HIGH TEMPERATURE REVERSE BIAS BURN-IN

No.	Characteristics	Symbol	Conditions	Unit
1	Ambient Temperature	$T_{amb}$	+150 (+0 -3)	°C
2	Reverse Voltage	$V_R$	Variants 10 to 16: Variants 20 to 26: Variants 30 to 36: Variants 40 to 46: Variants 50 to 56:	-12 -16 -24 -32 -36 V

**TABLE 5(b) - CONDITIONS FOR POWER BURN-IN AND OPERATING LIFE TEST**

No.	Characteristics	Symbol	Conditions	Unit
1	Ambient Temperature	$T_{amb}$	+125 (+0 -3)	°C
2	Forward Current	$I_F$	Variants 10 to 16, 20 to 26, 30 to 35: 50 Variants 40 to 45, 50 to 55: 50 Variants 36 and 46: 120 Variant 56: 130	mA

**FIGURE 5(a)- ELECTRICAL CIRCUIT FOR HIGH TEMPERATURE REVERSE BIAS BURN-IN**

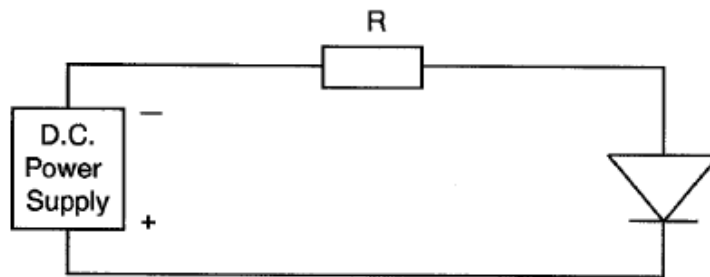

**NOTES**

- At the end of the HTRB,  $T_{amb}$  shall be decreased to room temperature and the reverse bias shall remain applied until  $T_{amb} < +35^{\circ}\text{C}$ .

**FIGURE 5(b) - ELECTRICAL CIRCUIT FOR POWER BURN-IN AND OPERATING LIFE TESTS**

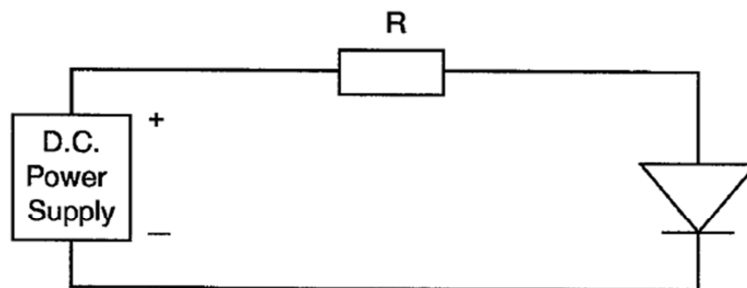

- 4.8 ENVIRONMENTAL AND ENDURANCE TESTS (CHARTS IV AND V OF ESCC GENERIC SPECIFICATION No. 5010)
- 4.8.1 Electrical Measurements on Completion of Environmental Tests  
The parameters to be measured on completion of environmental tests are scheduled in Table 2. Unless otherwise stated, the measurements shall be performed at  $T_{amb} = +22 \pm 3^{\circ}\text{C}$ .
- 4.8.2 Electrical Measurements at Intermediate Points and on Completion of Endurance Tests  
The parameters to be measured at intermediate points and on completion of endurance tests are scheduled in Table 6. Unless otherwise stated, the measurements shall be performed at  $T_{amb} = +22 \pm 3^{\circ}\text{C}$ .
- 4.8.3 Conditions for Operating Life Tests (Part of Endurance Testing)  
The requirements for operating life testing are specified in Section 9 of ESCC Generic Specification No. 5010. The conditions for operating life testing are specified in Table 5(b) of this specification.
- 4.8.4 Electrical Circuits for Operating Life Tests  
The circuit to be used for performance of the operating life test shall be the same as shown in Figure 5(b) for Power Burn-in.
- 4.9 TOTAL DOSE IRRADIATION TESTING  
Not applicable.
- 4.10 SPECIAL TESTING  
Not applicable.

**TABLE 6 – MEASUREMENTS AT INTERMEDIATE POINTS AND ON COMPLETION OF ENDURANCE TESTING**

No.	Characteristics	Symbol	Spec. And/Or Test Method	Test Conditions	Limits		Unit
					Min.	Max.	
1	Breakdown Voltage	$V_{BR}$	As per Table 2	As per Table 2	As per Table 2		V
2	Reverse Current	$I_R$	As per Table 2	As per Table 2	As per Table 2		nA
3	Forward Voltage	$V_F$	As per Table 2	As per Table 2	As per Table 2		V
4	Total Capacitance	$C_T$	As per Table 2	As per Table 2	As per Table 2		pF

**APPENDIX A**  
**AGREED DEVIATIONS FOR COBHAM MICROWAVE (F)**

ITEMS AFFECTED	DESCRIPTION OF DEVIATIONS
Para. 4.2.1	Para. 5.2, Wafer Lot Acceptance: Scanning Electron Microscope (SEM) Inspection shall be performed on one wafer per metallisation run. Three dice shall be selected at random after dicing.
Para. 4.2.2	Para. 9.12, Radiographic Inspection of Chart III(a): May be performed after Para. 9.7, PIND test.
Para. 4.2.3	Para. 9.1.2, Radiographic Inspection: May be performed after Para. 9.7, PIND test of Chart II(b).