



Pages 1 to 15

**CAPACITOR FILTERS, PI-TYPE, ELECTROMAGNETIC
INTERFERENCE SUPPRESSION, NON-HERMETICALLY
SEALED, SURFACE MOUNT**

BASED ON TYPE SFCMS 35 TYPE PI

ESCC Detail Specification No. 3008/037

Issue 1	July 2005
---------	-----------



Document Custodian: European Space Agency - see <https://escies.org>

LEGAL DISCLAIMER AND COPYRIGHT

European Space Agency, Copyright © 2005. All rights reserved.

The European Space Agency disclaims any liability or responsibility, to any person or entity, with respect to any loss or damage caused, or alleged to be caused, directly or indirectly by the use and application of this ESCC publication.

This publication, without the prior permission of the European Space Agency and provided that it is not used for a commercial purpose, may be:

- copied in whole, in any medium, without alteration or modification.
- copied in part, in any medium, provided that the ESCC document identification, comprising the ESCC symbol, document number and document issue, is removed.

DOCUMENTATION CHANGE NOTICE

(Refer to <https://escies.org> for ESCC DCR content)

DCR No.	CHANGE DESCRIPTION

TABLE OF CONTENTS

<u>1.</u>	<u>GENERAL</u>	<u>5</u>
1.1	Scope	5
1.2	Component Type Variants	5
1.3	Maximum Ratings	5
1.4	Parameter Derating Information	5
1.5	Physical Dimensions	5
1.6	Functional Diagram	5
<u>2.</u>	<u>APPLICABLE DOCUMENTS</u>	<u>5</u>
<u>3.</u>	<u>TERMS, DEFINITIONS, ABBREVIATIONS, SYMBOLS AND UNITS</u>	<u>5</u>
<u>4.</u>	<u>REQUIREMENTS</u>	<u>7</u>
4.1	General	7
4.2	Deviations from Generic Specification	7
4.2.1	Deviations from Special In-process Controls	7
4.2.2	Deviations from Final Production Tests (Chart II)	7
4.2.3	Deviations from Burn-in and Electrical Measurements (Chart III)	8
4.2.4	Deviations from Qualification Tests (Chart IV)	8
4.2.5	Deviations from Lot Acceptance Tests (Chart V)	8
4.3	Mechanical Requirements	8
4.3.1	Dimension Check	8
4.3.2	Weight	8
4.3.3	Robustness of Terminations	8
4.3.4	Solderability	9
4.4	Materials and Finishes	9
4.4.1	Case	9
4.4.2	Lead Material and Finish	9
4.5	Marking	9
4.5.1	General	9
4.5.2	The ESCC Component Number	10
4.5.3	Traceability Information	10
4.6	Electrical Measurements	10
4.6.1	Electrical Measurements at Room Temperature	10
4.6.2	Electrical Measurements at High and Low Temperatures	10
4.6.3	Circuits for Electrical Measurements (Figure 4)	10
4.7	Burn-in Tests	10
4.7.1	Parameter Drift Values	10
4.7.2	Conditions for Burn-in	10
4.7.3	Electrical Circuit for Burn-in (Figure 5)	10
4.8	Environmental and Endurance Tests (Charts IV and V of ESCC Generic Specification No. 3008)	12
4.8.1	Measurements and Inspections on Completion of Environmental Tests	12
4.8.2	Measurements and Inspections at Intermediate Points During Endurance Tests	12
4.8.3	Measurements and Inspections on Completion of Endurance Tests	12
4.8.4	Conditions for Operating Life	12
4.8.5	Electrical Circuit for Operating Life (Figure 5)	12

1. **GENERAL**

1.1 **SCOPE**

This specification details the ratings, physical and electrical characteristics, test and inspection data for a Capacitor Filter, Pi-Type, Electromagnetic Interference Suppression, Non-hermetically Sealed, Surface Mount, based on type SFCMS 35 Type Pi. It shall be read in conjunction with ESCC Generic Specification No. 3008, the requirements of which are supplemented herein.

1.2 **COMPONENT TYPE VARIANTS**

Variants of the basic type components specified herein, which are also covered by this specification are given in Table 1(a).

1.3 **MAXIMUM RATINGS**

The maximum ratings, which shall not be exceeded at any time during use or storage, applicable to the components specified herein, are as scheduled in Table 1(b).

1.4 **PARAMETER DERATING INFORMATION**

The parameter derating information applicable to the components specified herein, is shown in Figure 1.

1.5 **PHYSICAL DIMENSIONS**

The physical dimensions of the components specified herein are shown in Figure 2.

1.6 **FUNCTIONAL DIAGRAM**

The functional diagram of the components specified herein is shown in Figure 3.

2. **APPLICABLE DOCUMENTS**

The following documents form part of this specification and shall be read in conjunction with it:

- (a) ESCC Generic Specification No. 3008 for Capacitors and Capacitor Filters, Feedthrough.
- (b) MIL-STD-202, Test Methods for Electronic and Electrical Component Parts.

3. **TERMS, DEFINITIONS, ABBREVIATIONS, SYMBOLS AND UNITS**

For the purpose of this specification, the terms, definitions, abbreviations, symbols and units specified in ESCC Basic Specification No. 21300 shall apply.

Table 1(a) - TYPE VARIANTS

Variant	Rated DC Voltage U_R (V)		Insulation Resistance R_i (G Ω)		Voltage Proof VP (V)	Capacitance C (pF)	Insertion Loss I_L (dB) with no current applied			
	-55 to +85°C	+85 to +125°C	-55 to +25°C	+25 to +125°C			1MHz	10MHz	100MHz	1GHz
01	200	100	10	1	500	2400	-	10	47	70
02	200	100	10	1	500	19200	-	29	65	70
03	100	70	3	0.3	250	44800	-	39	54	70
04	50	35	5	0.5	125	35200	10	38	65	70

Table 1(b) - MAXIMUM RATINGS

No.	Characteristics	Symbol	Maximum Ratings	Unit	Remarks
1	Rated DC Voltage	U_R	See Table 1(a)	V	Note 1
2	Voltage Drop	V_{dr}	100	mV	
3	DC Resistance	R_S	10	m Ω	
4	DC and Low Frequency Current	I_R	10	A	
5	Operating Temperature Range	T_{op}	-55 to +125	°C	T_{amb}
6	Storage Temperature Range	T_{stg}	-55 to +125	°C	
7	Soldering Temperature	T_{sol}	+260	°C	Note 2

NOTES:

1. The addition of DC applied voltage and ripple voltage shall never exceed the rated DC voltage.
2. Duration 6 seconds maximum and the same termination, or the case, shall not be resoldered until 3 minutes have elapsed.

FIGURE 1- PARAMETER DERATING INFORMATION

See Table 1(a).

FIGURE 2 - PHYSICAL DIMENSIONS

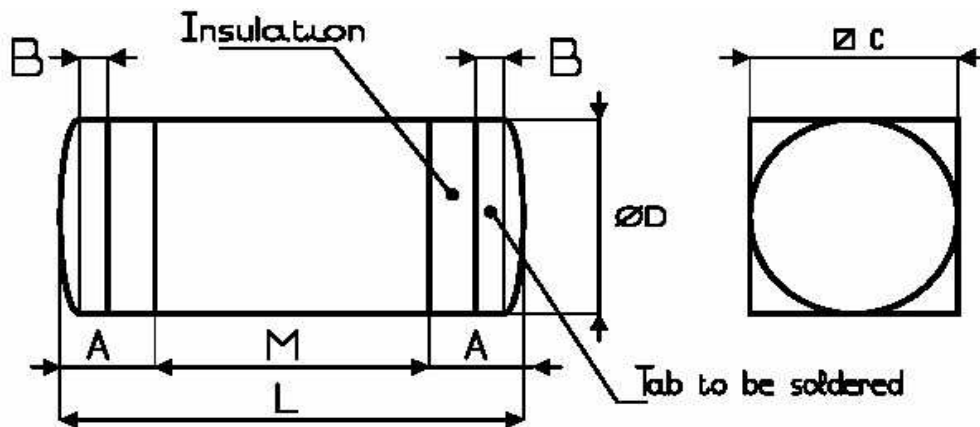

Symbol	Dimensions (mm)		Remarks
	Min	Max	
A	1.9	2.6	
B	0.7	0.9	
C	3.5	3.6	Note 1
ØD	3.5	3.6	Note 2
L	11.3	12.7	
M	7.4	7.6	

NOTES:

1. This dimension applies to the square-section case (Ground), over dimension M. One of the four faces shall bear marking in accordance with Para. 4.5.
2. This dimension (diameter) applies to both the tab termination and the insulation.

FIGURE 3 - FUNCTIONAL DIAGRAM

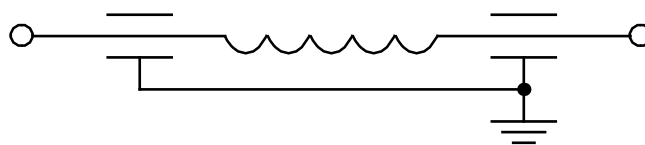

4. REQUIREMENTS

4.1 GENERAL

The complete requirements for procurement of the components specified herein are stated in this specification and ESCC Generic Specification No. 3008 for Capacitors and Capacitor Filters, Feedthrough. Deviations from the Generic Specification, applicable to this specification only, are detailed in Para. 4.2.

Deviations from the applicable Generic Specification and this Detail Specification, formally agreed with specific Manufacturers on the basis that the alternative requirements are equivalent to the ESCC requirements and do not affect the components' reliability, are listed in the appendices attached to this specification.

4.2 DEVIATIONS FROM GENERIC SPECIFICATION

4.2.1 Deviations from Special In-process Controls

None.

4.2.2 Deviations from Final Production Tests (Chart II)

- (a) Para. 9.4.1.5, Voltage Drop: Shall be performed as a DC resistance measurement in accordance with MIL-STD-202, Method 303.
- (b) Para. 9.2, Rapid Change of Temperature: The Components may not be mounted.

- (c) Para. 9.3, Vibration: Not applicable.

4.2.3 Deviations from Burn-in and Electrical Measurements (Chart III)

- (a) Para. 9.4.1.5, Voltage Drop: Shall be performed as a DC resistance measurement in accordance with MIL-STD-202, Method 303.
- (b) Paras. 9.4.3, Electrical Measurements at High and Low Temperature and 9.4.4, Electrical Measurements at Room Temperature: Insertion Loss is considered as destructive and the parts so tested cannot be delivered as flight models. Therefore, these tests shall be performed at the end of Chart III and parts rejected during External Visual Inspection or Radiographic Inspection, but electrically acceptable after Burn-in, may be used.

4.2.4 Deviations from Qualification Tests (Chart IV)

- (a) Para. 9.4.1.4, Insertion Loss: Measurements at a minimum of four test frequencies is permitted.
- (b) Para. 9.4.1.5, Voltage Drop: Shall be performed as a DC resistance measurement in accordance with MIL-STD-202, Method 303.
- (c) Para. 9.12, Accelerated Damp Heat: Voltage Proof and Insertion Loss shall not be performed.
- (d) Para. 9.14, Robustness of Terminations: Only test Ua is applicable.
- (e) Para. 9.15, Immersion: Not applicable.
- (f) Para. 9.17, Resistance to Soldering Heat: May be performed prior to Para. 9.11, Vibration. Capacitance is performed in lieu of Insertion Loss at Final Measurements.
- (g) Para. 9.18, Solderability: May be performed prior to Para. 9.10, Shock.
- (h) Para. 9.19, Operating Life (Intermediate and End Data Points): Insertion Loss shall not be performed.

4.2.5 Deviations from Lot Acceptance Tests (Chart V)

- (a) Para. 9.4.1.5, Voltage Drop: Shall be performed as a DC resistance measurement in accordance with MIL-STD-202, Method 303.
- (b) Para. 9.14, Robustness of Terminations: Only test Ua is applicable.
- (c) Para. 9.15, Immersion: Not applicable.
- (d) Para. 9.18, Solderability: May be performed prior to Para. 9.10, Shock.
- (e) Para. 9.19, Operating Life (Intermediate and End Data Points): Insertion Loss shall not be performed.

4.3 MECHANICAL REQUIREMENTS

4.3.1 Dimension Check

The dimensions of the components specified herein shall be verified in accordance with the requirements set out in Para. 9.5 of ESCC Generic Specification No. 3008 and they shall conform to those shown in Figure 2 of this specification.

4.3.2 Weight

The maximum weight of the components specified herein shall be 2 grammes.

4.3.3 Robustness of Terminations

The requirements for the robustness of terminations tests are specified in Para. 9.14 of the Generic Specification and below.

Add to Para. 9.14.1 of the Generic Specification

For surface mount components, capacitors shall be mounted on a suitable substrate. After mounting, examination shall be made for good tinning as evidenced by flowing of the solder with wetting of the terminations.

Add to Para. 9.14.2 (for method Ua) of the Generic Specification

For surface mount components, a force of 10N shall be applied on the terminations normal to the length of the case and in a plane parallel to the substrate, duration = 10s.

Add to Para. 9.14.3 of the Generic Specification

For surface mount components, there shall be no evidence of damage or loosening of the components from the substrate.

4.3.4 Solderability

The requirements for solderability testing are specified in Para. 9.18 of the Generic Specification and below.

The test shall be carried out in accordance with IEC 68-2-20 standard with the following conditions:

- Test Ta, Method 1
- Temperature: $+235\pm 3^{\circ}\text{C}$
- Immersion time: 3 ± 0.3 seconds

The terminations shall be immersed to their interface with the insulation (see Figure 2).

4.4 MATERIALS AND FINISHES

The materials and finishes shall be as specified herein. Where a definite material is not specified, a material which will enable the components specified herein to meet the performance requirements of this specification shall be used. Acceptance or approval of any constituent material does not guarantee acceptance of the finished product.

4.4.1 Case

The case shall be silver plated brass.

4.4.2 Lead Material and Finish

The tab material shall be brass with tin-lead layer (lead>95%) with Nickel and Silver underplating.

4.5 MARKING

4.5.1 General

The marking of components delivered to this specification shall be in accordance with the requirements of ESCC Basic Specification No. 21700 and the following paragraphs. When the component is too small to accommodate all of the marking specified, as much as space permits shall be marked and the marking information, in full, shall accompany the component in its primary package.

The information to be marked and the order of precedence, shall be as follows:

- (a) The ESCC Component Number.
- (b) Traceability Information

4.5.2 The ESCC Component Number

The ESCC Component Number shall be constituted and marked as follows:

Example: 300803701B

- Detail Specification Reference: 3008037
- Component Type Variant Number: 01 (as required)
- Testing Level (B or C, as applicable)

4.5.3 Traceability Information

Each component shall be marked in respect of traceability information in accordance with the requirements of ESCC Basic Specification No. 21700.

4.6 ELECTRICAL MEASUREMENTS

4.6.1 Electrical Measurements at Room Temperature

The parameters to be measured at room temperature are scheduled in Table 2. Unless otherwise specified, measurements shall be performed at $T_{amb}=+22\pm3^{\circ}\text{C}$.

4.6.2 Electrical Measurements at High and Low Temperatures

The parameters to be measured at high and low temperatures are scheduled in Table 3. Measurements shall be performed at $T_{amb}+125(+0-5)^{\circ}\text{C}$ and $-55(+5-0)^{\circ}\text{C}$ respectively.

4.6.3 Circuits for Electrical Measurements (Figure 4)

Not applicable.

4.7 BURN-IN TESTS

4.7.1 Parameter Drift Values

The parameter drift values applicable to Burn-in are as specified in Table 4 of this specification. Unless otherwise stated, measurements shall be performed at $T_{amb}=+22\pm3^{\circ}\text{C}$. The parameter drift values (Δ) applicable to the parameters scheduled shall not be exceeded. In addition to these drift value requirements for a given parameter, the appropriate limit values specified in Table 2 shall not be exceeded.

4.7.2 Conditions for Burn-in

The requirements for Burn-in are specified in Section 7 of ESCC Generic Specification No. 3008. The conditions for Burn-in shall be as specified in Table 5(a) of this specification.

4.7.3 Electrical Circuit for Burn-in (Figure 5)

Not applicable.

Table 2 - ELECTRICAL MEASUREMENTS AT ROOM TEMPERATURE - DC PARAMETERS

No.	Characteristics	Symbol	ESCC 3008 Test Method	Test Conditions	Limits		Unit
					Min	Max	
1	DC Resistance	R_S	MIL-STD-202 Method 303	-	-	10	$\text{m}\Omega$

No.	Characteristics	Symbol	ESCC 3008 Test Method	Test Conditions	Limits		Unit
					Min	Max	
2	Voltage Proof	VP	Para. 9.4.1.2	-	Note 1	-	V
3	Insulation Resistance	Ri	Para. 9.4.1.3	Para. 9.4.1.3	Note 1	-	GΩ

Table 2 - ELECTRICAL MEASUREMENTS AT ROOM TEMPERATURE - AC PARAMETERS

No.	Characteristics	Symbol	ESCC 3008 Test Method	Test Conditions	Limits		Unit
					Min	Max	
4	Insertion Loss	I_{L1}	Para. 9.4.1.4	f=1MHz, Note 2	Note 1	-	dB
5	Insertion Loss, Note 5	I_{L2}	Para. 9.4.1.4	f=10MHz, Note 3	Note 1	-	dB
6	Insertion Loss, Note 5	I_{L3}	Para. 9.4.1.4	f=100MHz, Note 3	Note 1	-	dB
7	Insertion Loss, Note 5	I_{L4}	Para. 9.4.1.4	f=1GHz, Note 3	Note 1	-	dB
8	Capacitance	C	Para. 9.4.1.1	f=1kHz±100Hz V=0.1 to 1.2Vrms	Note 1	-	pF

Table 3 - ELECTRICAL MEASUREMENTS AT HIGH AND LOW TEMPERATURES

No.	Characteristics	Symbol	ESCC 3008 Test Method	Test Conditions	Limits		Unit
					Min	Max	
3	Insulation Resistance Note 4	Ri	Para. 9.4.1.3	Para. 9.4.1.3 $T_{amb}=+125(+0 -5)^\circ\text{C}$	Note 1	-	GΩ
5	Insertion Loss Note 5	I_{L2}	Para. 9.4.1.4	f=10MHz, No current	Note 1	-	dB
6	Insertion Loss Note 5	I_{L3}	Para. 9.4.1.4	f=100MHz, No current	Note 1	-	dB
7	Insertion Loss Note 5	I_{L4}	Para. 9.4.1.4	f=1GHz, No current	Note 1	-	dB

NOTES TO TABLES 2 AND 3:

1. See Table 1(a).
2. Measurements at this frequency to be made only during Chart IV testing.
3. Measurements at rated current to be made only during Chart IV testing. Measurements without load current to be made during Charts III and V. NB: not performed during Chart II testing.
4. This measurement must be carried out at the end of the Burn-in in accordance with Para. 9.23 of ESCC Generic Specification No. 3008 and shall not be carried out again.
5. Measurements at Room, High and Low Temperatures to be made on a sample of 5 parts per lot. If one or more failures occur then another 5 samples shall be tested. If one or more of the additional 5 samples fails then the lot shall be rejected. The samples shall be mounted on a suitable substrate prior to measurements. See also Para. 4.2.3.

FIGURE 4 - CIRCUITS FOR ELECTRICAL MEASUREMENTS

Not applicable.

Table 4 - PARAMETER DRIFT VALUES

No.	Characteristics	Symbol	Spec. and/or Test Method	Test Conditions	Change Limits (Δ)	Unit
8	Capacitance Change	$\Delta C/C$	As per Table 2	As per Table 2	±10	%

Table 5(a) - CONDITIONS FOR BURN-IN

No.	Characteristics	Symbol	Condition	Unit
1	Ambient Temperature	T_{amb}	+125(+0 -3)	°C
2	Test Voltage	V_T	2xU _R at +125°C Note 1	V

NOTES:

1. Applied between one tab and the case. See Table 1(a) for value of U_R.

Table 5(b) - CONDITIONS FOR OPERATING LIFE

No.	Characteristics	Symbol	Condition	Unit
1	Ambient Temperature	T_{amb}	+125(+0 -3)	°C
2	Test Voltage	V_T	2xU _R at +125°C Note 1	V
3	Rated Current	I _R	10	A

NOTES:

1. Applied between one tab and the case. See Table 1(a) for value of U_R.

FIGURE 5 - ELECTRICAL CIRCUIT FOR BURN-IN AND OPERATING LIFE

Not applicable.

4.8 ENVIRONMENTAL AND ENDURANCE TESTS (CHARTS IV AND V OF ESCC GENERIC SPECIFICATION NO. 3008)

4.8.1 Measurements and Inspections on Completion of Environmental Tests

The parameters to be measured and inspections to be performed on completion of environmental tests are scheduled in Table 6. Unless otherwise stated, the measurements shall be performed at T_{amb}=+22±3°C.

4.8.2 Measurements and Inspections at Intermediate Points During Endurance Tests

The parameters to be measured and inspections to be performed at intermediate points during endurance tests are scheduled in Table 6. Unless otherwise stated, the measurements shall be performed at T_{amb}=+22±3°C.

4.8.3 Measurements and Inspections on Completion of Endurance Tests

The parameters to be measured and inspections to be performed on completion of endurance tests are scheduled in Table 6. Unless otherwise stated, the measurements shall be performed at T_{amb}=+22±3°C.

4.8.4 Conditions for Operating Life

The requirements for operating life test are specified in Section 9 of ESCC Generic Specification No. 3008. The conditions for operating life testing shall be as specified in Table 5(b) of this specification.

4.8.5 Electrical Circuit for Operating Life (Figure 5)

Not applicable.

Table 6 - MEASUREMENTS AND INSPECTIONS ON COMPLETION OF ENVIRONMENTAL TESTS AND AT INTERMEDIATE POINTS AND ON COMPLETION OF ENDURANCE TESTING

No.	ESCC Generic Spec. No. 3008		Measurements and Inspections		Symbol	Limits		Unit
	Environmental and Endurance Tests (1)	Test Methods and Conditions	Identification	Conditions		Min	Max	
01	Seal Test (Hermetically Sealed)	Para. 9.6	Not applicable					
02	External Visual Inspection	Para. 9.7	<u>Final Measurements</u> Visual Inspection	ESCC No. 20500	-	-	-	-
03	Temperature Rise	Para. 9.9	Temperature Rise	Rated Current (3)	-	-	25	°C
04	Shock	Para. 9.10	<u>Measurements during Tests</u>	100% U _R (2) applied No Open or Short Circuits >100µs				
			<u>Final Measurements</u> Visual Examination	No Mechanical Damage	-	-	-	-
			Insertion Loss	Table 2 Items 4 to 7	I _L	Table 2	-	dB
05	Vibration	Para. 9.11	<u>Measurements during Tests</u> During last cycle	Current (7) and 100% U _R (2) applied No Open or Short Circuits >100µs				
			<u>Final Measurements</u> Visual Examination	No Mechanical Damage	-	-	-	-
			Insertion Loss	Table 2 Items 4 to 7	I _L	Table 2	-	dB
06	Accelerated Damp Heat	Para. 9.12 and Para. 4.2.4 of this spec.	<u>Final Measurements</u>	After recovery of 4 to 24 hours				
			Visual Examination	No corrosion or obliteration of marking	-	-	-	-
			Insulation Resistance	Table 2 Item 3	R _i	(5)	-	GΩ
07	Low Air Pressure	Para. 9.13	<u>Measurements during Tests</u>	during last 5 minutes				
			Voltage Proof	Table 2 Item 2	VP	125% U _R (2)	-	V
			Visual Examination	No breakdown, flashover, deformation or seepage	-	-	-	-
			<u>Final Measurements</u> Visual Examination	No breakdown, flashover, deformation or seepage	-	-	-	-
08	Robustness of Terminations	Para. 9.14 and Paras. 4.2.4, 4.2.5 and 4.3.3 of this spec.	<u>Final Measurements</u>					
			Visual Examination DC Resistance	No damage Table 2 Item 1	- R _S	- -	- Table 2	- mΩ

No.	ESCC Generic Spec. No. 3008		Measurements and Inspections		Symbol	Limits		Unit
	Environmental and Endurance Tests (1)	Test Methods and Conditions	Identification	Conditions		Min	Max	
09	Immersion	Para. 9.15 and Paras. 4.2.4 and 4.2.5 of this spec.	Not applicable					
10	Overload	Para. 9.16	<u>Final Measurements</u> Insulation Resistance DC Resistance Visual Examination	140% of Rated Current (3) for 15 mins min. Table 2 Item 3 Table 2 Item 1 No damage	Ri R _S -	Table 2 - -	- Table 2 -	GΩ mΩ -
11	Resistance to Soldering Heat	Para. 9.17 and Para. 4.2.4(b) of this spec.	<u>Final Measurements</u> Visual Examination Insulation Resistance Capacitance	After recovery of 1 to 2 hrs No damage Table 2 Item 3 Table 2 Item 8	- Ri C	- Table 2 Table 2	- - -	- GΩ pF
12	Solderability	Para. 9.18 and Para. 4.3.4 of this spec	<u>Final Measurements</u> Visual Examination	IEC No. 68-2-20 Para. 4.6.4, 4.7.4 or 4.9.3	-	-	-	-
13	Operating Life	Para. 9.19 and Paras. 4.2.4 and 4.2.5 of this spec.	During tests <u>Initial Measurements</u> Voltage Drop Voltage Proof Insulation Resistance Capacitance <u>Intermediate Measurements</u> Insulation Resistance Voltage Drop Voltage Proof Insulation Resistance	Open or short Circuit ESCC 3008, Para. 9.4.1.5 Table 2, Item 2 Table 2, Item 3 Table 2, Item 8 Table 3, Item 3 After 24 hours recovery ESCC 3008, Para. 9.4.1.5 Table 2, Item 2 Table 2, Item 3	V _{dr} VP Ri C Ri V _{dr} VP Ri	- 90% U _R (2) Table 2 Table 2 Table 3 - 90% U _R (2) (4)	- (6) - - - (6) - -	V V GΩ pF GΩ V V GΩ

No.	ESCC Generic Spec. No. 3008		Measurements and Inspections		Symbol	Limits		Unit
	Environmental and Endurance Tests (1)	Test Methods and Conditions	Identification	Conditions		Min	Max	
			Capacitance	Table 2, Item 8	C	Table 2	-	pF
			Capacitance Change	Table 2, Item 8	$\Delta C/C$	-	Table 4	%
			<u>Final Measurements</u>					
			Insulation Resistance	Table 3, Item 3	Ri	Table 3	-	G Ω
				After 24 hours recovery				
			Voltage Drop	ESCC 3008, Para. 9.4.1.5	V _{dr}	-	(6)	V
			Voltage Proof	Table 2, Item 2	VP	90% U _R (2)	-	V
			Insulation Resistance	Table 2, Item 3	Ri	(4)	-	G Ω
			Capacitance	Table 2, Item 8	C	Table 2	-	pF
			Capacitance Change	Table 2, Item 8	$\Delta C/C$	-	Table 4	%
14	Corrosion	Para. 9.20	<u>Final Measurements</u>					
			Visual Examination	No corrosion, damage or obliteration of marking	-	-	-	-
15	Permanence of Marking	Para. 9.21	<u>Final Measurements</u>					
			Visual Examination	No corrosion or obliteration of marking	-	-	-	-
16	Damp Heat (Non-hermetically Sealed)	Para. 9.24	<u>Final Measurements</u>	After 4 hours recovery				
			Visual Examination	No cracking or encapsulant separation	-	-	-	-
			Insulation Resistance	Under 1.5V	Ri	(5)	-	G Ω

NOTES:

1. The tests in this Table refer to either Chart IV or V and shall be used as applicable.
2. For U_R, see Table 1(a).
3. For I_R, see Table 1(b).
4. Greater than 50% of the value given in Table 2.
5. Greater than 10% of the value given in Table 2.
6. For Voltage Drop limit, see Table 1(b).
7. The minimum current required for monitoring purposes shall be applied (See Para. 9.11.3 of ESCC Generic Specification No. 3008).