



Pages 1 to 17

TRANSISTORS, POWER, MOSFET, P-CHANNEL

BASED ON TYPE 2N6849

ESCC Detail Specification No. 5206/003

Issue 3	July 2009
---------	-----------



Document Custodian: European Space Agency - see <https://spacecomponents.org>

LEGAL DISCLAIMER AND COPYRIGHT

European Space Agency, Copyright © 2009. All rights reserved.

The European Space Agency disclaims any liability or responsibility, to any person or entity, with respect to any loss or damage caused, or alleged to be caused, directly or indirectly by the use and application of this ESCC publication.

This publication, without the prior permission of the European Space Agency and provided that it is not used for a commercial purpose, may be:

- copied in whole, in any medium, without alteration or modification.
- copied in part, in any medium, provided that the ESCC document identification, comprising the ESCC symbol, document number and document issue, is removed.

DOCUMENTATION CHANGE NOTICE

(Refer to <https://escies.org> for ESCC DCR content)

DCR No.	CHANGE DESCRIPTION
510	Specification up issued to incorporate editorial and technical changes per DCR.

TABLE OF CONTENTS

<u>1.</u>	<u>GENERAL</u>	<u>5</u>
1.1	Scope	5
1.2	Applicable Documents	5
1.3	Terms, Definitions, Abbreviations, Symbols and Units	5
1.4	The ESCC Component Number and Component Type Variants	5
1.4.1	The ESCC Component Number	5
1.4.2	Component Type Variants	5
1.5	Maximum Ratings	5
1.6	Physical Dimensions and Terminal Identification	8
1.6.1	Metal Can Package (TO-205AF) - 3 Lead	8
1.7	Functional Diagram	9
1.8	Materials and Finishes	9
<u>2.</u>	<u>REQUIREMENTS</u>	<u>9</u>
2.1	General	9
2.1.1	Deviations from the Generic Specification	10
2.1.1.1	Deviation from Screening Tests - Chart F3	10
2.2	Wafer Lot Acceptance	10
2.3	Marking	10
2.4	Verification of Safe Operating Area	10
2.5	Terminal Strength	10
2.6	Electrical Measurements at Room, High and Low Temperatures	10
2.6.1	Room Temperature Electrical Measurements	10
2.6.2	High and Low Temperatures Electrical Measurements	14
2.7	Parameter Drift Values	15
2.8	Intermediate and End-Point Electrical Measurements	15
2.9	High Temperature Reverse Bias Burn-in Conditions	16
2.10	Power Burn-in Conditions	16
2.11	Operating Life Conditions	17

1. GENERAL

1.1 SCOPE

This specification details the ratings, physical and electrical characteristics and test and inspection data for the component type variants and/or the range of components specified below. It supplements the requirements of, and shall be read in conjunction with, the ESCC Generic Specification listed under Applicable Documents.

1.2 APPLICABLE DOCUMENTS

The following documents form part of this specification and shall be read in conjunction with it:

- (a) ESCC Generic Specification No. 5000
- (b) MIL-STD-750, Test Methods and Procedures for Semiconductor Devices

1.3 TERMS, DEFINITIONS, ABBREVIATIONS, SYMBOLS AND UNITS

For the purpose of this specification, the terms, definitions, abbreviations, symbols and units specified in ESCC Basic Specification No. 21300 shall apply.

1.4 THE ESCC COMPONENT NUMBER AND COMPONENT TYPE VARIANTS

1.4.1 The ESCC Component Number

The ESCC Component Number shall be constituted as follows:

520600301

- Detail Specification Reference: 5206003
- Component Type Variant Number: 01

1.4.2 Component Type Variants

The component type variants applicable to this specification are as follows:

Variant No.	Based on Type	Case	Lead/Terminal Material and Finish	Weight max g
01	2N6849	TO-205AF	D2	1.1

The lead/terminal material and finish shall be in accordance with the requirements of ESCC Basic Specification No. 23500.

1.5 MAXIMUM RATINGS

The maximum ratings shall not be exceeded at any time during use or storage.

Maximum ratings shall only be exceeded during testing to the extent specified in this specification and when stipulated in Test Methods and Procedures of the ESCC Generic Specification.

Characteristics	Symbols	Maximum Ratings	Unit	Remarks
Drain-Source Voltage	V_{DS}	-100	V	Over T_{op} Note 3
Gate-Source Voltage	V_{GS}	± 20	V	Over T_{op}
Drain-Gate Voltage	V_{DG}	-100	V	Over T_{op}
Drain Current	I_D	-6.5	A	Continuous At $T_{case}=+25^{\circ}C$ Notes 1, 2, 3
Source Current	I_S	-6.5	A	Continuous At $T_{case}=+25^{\circ}C$ Note 1
Drain Current Pulsed	I_{DM}	-25	A	Peak Note 1
Power Dissipation	P_{tot}	25	W	At $T_{case} \leq +25^{\circ}C$
Thermal Resistance, Junction-to-Case	$R_{th(j-c)}$	5	$^{\circ}C/W$	
Operating Temperature Range	T_{op}	-55 to +150	$^{\circ}C$	Note 4
Storage Temperature Range	T_{stg}	-55 to +150	$^{\circ}C$	Note 4
Soldering Temperature	T_{sol}	+300	$^{\circ}C$	Note 5

NOTES:

1. These ratings apply at the case. Leads are not capable of carrying maximum drain or source

currents beyond 2mm from the case without heatsink.

- For $T_{case} > +25^{\circ}C$, I_D is derated using the following formula:

$$-I_D(A) = \sqrt{\frac{P_{rated}(W)}{0.6}}, \text{ where } P_{rated}(W) = 25 - (0.2 \times (T_{case} - 25))$$

- Safe Operating Area applies as follows:

Maximum Safe Operating Area Graph

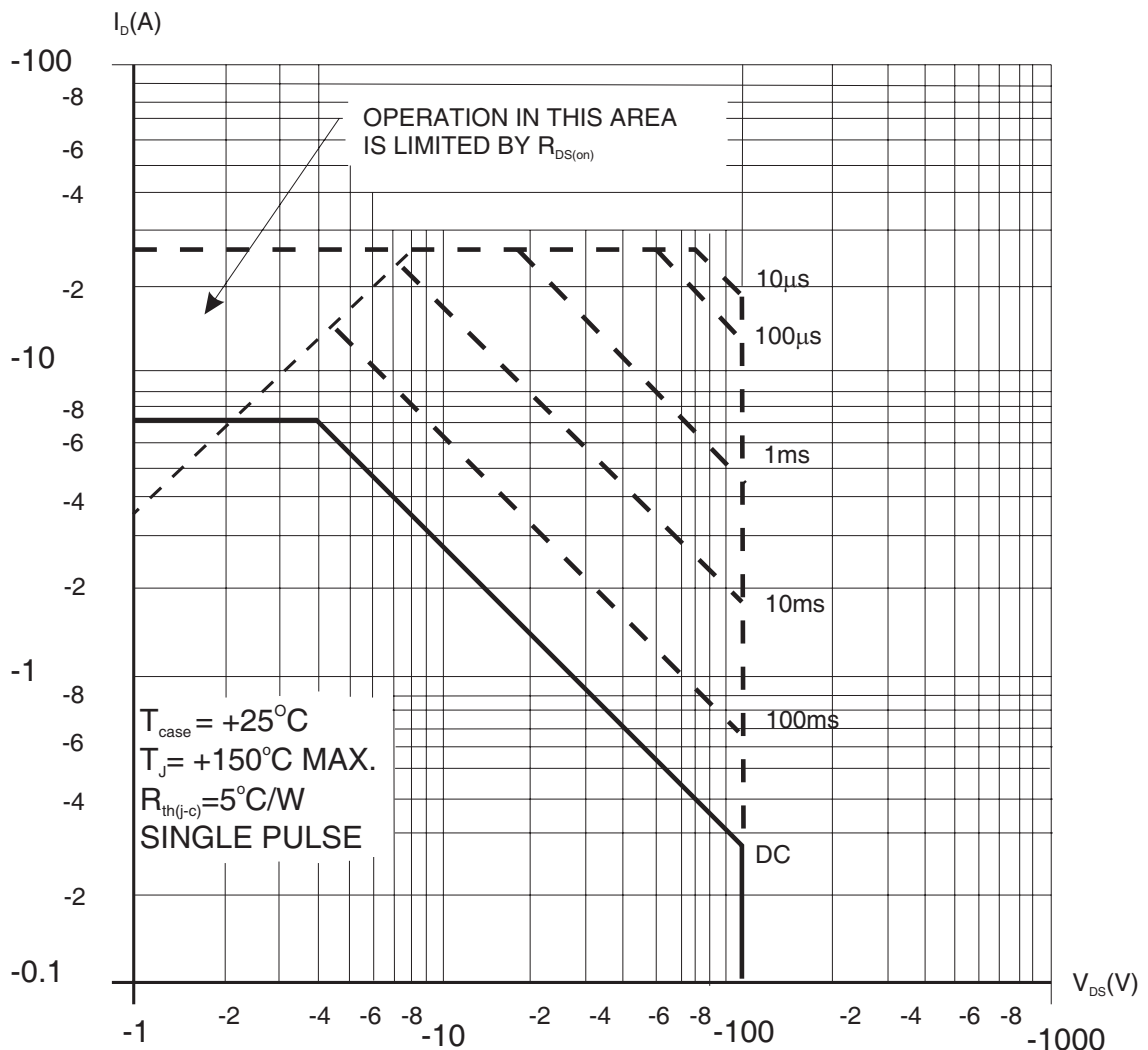

- For Variants with tin-lead plating or hot solder dip lead finish all testing performed at $T_{amb} > +125^{\circ}C$ shall be carried out in a 100% inert atmosphere.
- Duration 10 seconds maximum at a distance of not less than 1.5mm from the device body and the same lead shall not be resoldered until 3 minutes have elapsed.

1.6 PHYSICAL DIMENSIONS AND TERMINAL IDENTIFICATION

1.6.1 Metal Can Package (TO-205AF) - 3 Lead

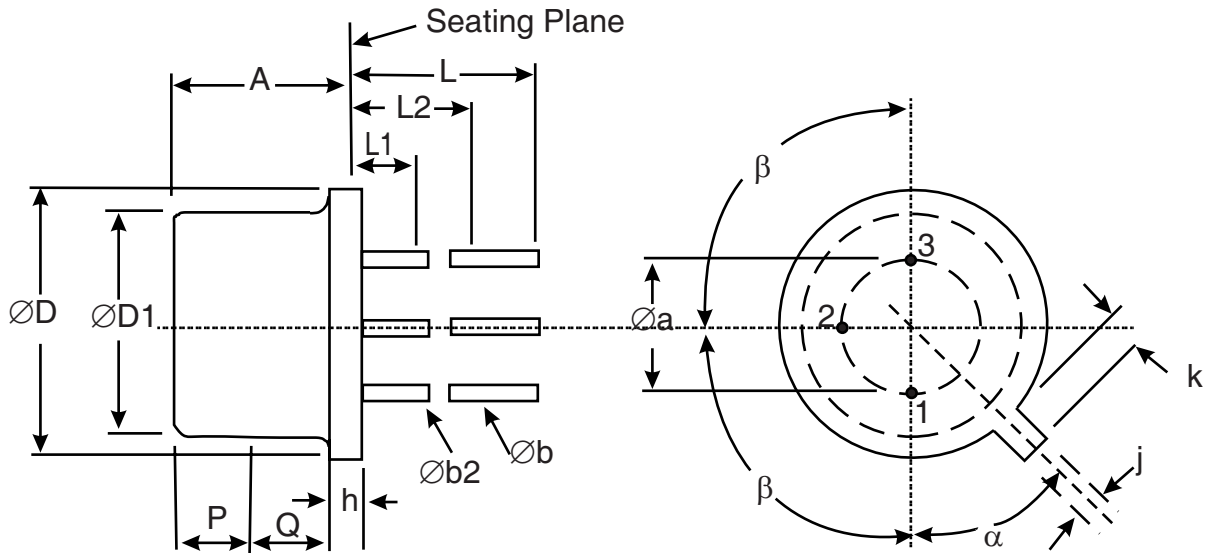

Symbols	Dimensions mm		Notes
	Min	Max	
$\varnothing a$	5.08 BSC		4
A	4.07	4.57	
$\varnothing b$	0.4	0.533	2, 3
$\varnothing b2$	0.4	0.483	2, 3
$\varnothing D$	8.51	9.4	
$\varnothing D1$	7.75	8.51	6
h	0.229	1.27	
j	0.71	0.864	
k	0.737	1.14	5
L	12.7	19	2
L1	-	1.27	2, 3
L2	6.35	-	2, 3
P	2.54	-	6
Q	-	-	7
α	45° BSC		1, 8
β	90° BSC		1

NOTES:

1. Terminal identification is specified by reference to the tab position where Lead 1 = source, Lead 2 = gate and Lead 3 = drain.
2. Applies to all leads.
3. $\varnothing b2$ applies between L1 and L2. $\varnothing b$ applies between L2 and 12.7mm from the seating plane.

Diameter is uncontrolled within L1 and beyond 12.7mm from the seating plane.

4. Leads having maximum diameter 0.483mm measured in the gauging plane 1.37(+0.025,-0)mm below the seating plane of the device shall be within 0.178mm of their true position relative to a maximum-width-tab.
5. Measured from the maximum diameter of the actual device.
6. This zone is controlled for automatic handling. The variation in actual diameter within this zone shall not exceed 0.254mm.
7. The details of outline in this zone are optional.
8. Measured from the Tab Centreline.

1.7 FUNCTIONAL DIAGRAM

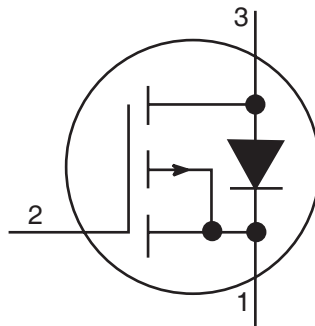

1. Source.
2. Gate.
3. Drain.

NOTES:

1. The drain is internally connected to the case.

1.8 MATERIALS AND FINISHES

Materials and finishes shall be as follows:

- a) Case
The case shall be hermetically sealed and have a metal body with hard glass seals.
- b) Leads/Terminals
As specified in Component Type Variants.

2. REQUIREMENTS

2.1 GENERAL

The complete requirements for procurement of the components specified herein are as stated in this specification and the ESCC Generic Specification. Permitted deviations from the Generic Specification, applicable to this specification only, are listed below.

Permitted deviations from the Generic Specification and this Detail Specification, formally agreed with specific Manufacturers on the basis that the alternative requirements are equivalent to the ESCC requirement and do not affect the component's reliability, are listed in the appendices attached to this specification.

2.1.1 Deviations from the Generic Specification

2.1.1.1 *Deviation from Screening Tests - Chart F3*

Verification of Safe Operating Area tests shall be performed after Power Burn-In and before Parameter Drift Values (Final Measurements).

2.2 WAFER LOT ACCEPTANCE

SEM Inspection shall be performed as defined in Chart F2 and Para. 5.3.2 of the ESCC Generic Specification.

2.3 MARKING

The marking shall be in accordance with the requirements of ESCC Basic Specification No. 21700 and as follows.

The information to be marked on the component shall be:

- (a) The ESCC qualified components symbol (for ESCC qualified components only).
- (b) The ESCC Component Number.
- (c) Traceability information.

2.4 VERIFICATION OF SAFE OPERATING AREA

The Safe Operating Area shall be verified as specified in the ESCC Generic Specification and Maximum Ratings herein. The test method and conditions shall be as follows:

MIL-STD-750, Test Method 3474. $T_{\text{case}} = +25 \pm 10^{\circ}\text{C}$.

Test Number 1: Single pulse, duration 100ms. $V_{\text{DS}} = -80\text{V}$, $I_{\text{D}} = -310\text{mA}$, $R_{\text{S}} = 8.06\Omega$.

Test Number 2: Single pulse, duration 100ms. $V_{\text{DS}} = -3.85\text{V}$, $I_{\text{D}} = -6.5\text{A}$, $R_{\text{S}} = 383\text{m}\Omega$.

2.5 TERMINAL STRENGTH

The test conditions for terminal strength, tested as specified in the ESCC Generic Specification, shall be as follows:

Test Condition: E, lead fatigue.

2.6 ELECTRICAL MEASUREMENTS AT ROOM, HIGH AND LOW TEMPERATURES

Electrical measurements shall be performed at room, high and low temperatures.

2.6.1 Room Temperature Electrical Measurements

The measurements shall be performed at $T_{\text{amb}} = +22 \pm 3^{\circ}\text{C}$.

Characteristics	Symbols	MIL-STD-750 Test Method	Test Conditions	Limits		Units
				Min	Max	
Drain-Source Breakdown Voltage	$V_{(BR)DSS}$	3407	$I_D=-250\mu A$ $V_{GS}=0V$ Bias condition C	-100	-	V
Gate-Source Threshold Voltage	$V_{GS(th)}$	3403	$V_{DS}\geq V_{GS}$ $I_D=-250\mu A$	-2	-4	V
Gate-Body Leakage Current	I_{GSS}	3411	$V_{GS}=-20V$ $V_{DS}=0V$ Bias condition C	-	-100	nA
Drain Current	I_{DSS}	3413	$V_{DS}=-80V$ $V_{GS}=0V$ Bias condition C	-	-250	μA
Drain-Source On-state Resistance	$r_{DS(on)}$	3421	$V_{GS}=-10V$ $I_D=-4.1A$ Test Condition A Notes 1, 2	-	300	m Ω
Drain-Source On-state Voltage	$V_{DS(on)}$	3405	$V_{GS}=-10V$ $I_D=-6.5A$ Test Condition A Notes 1, 2	-	-2	V
Diode Forward Voltage	V_{SD}	4011	$V_{GS}=0V$ $I_S=-6.5A$ Note 1	-2	-4.3	V
Forward Trans-conductance	g_{fs}	3475	$V_{DS}=-5V$ $I_D=-4.1A$ Notes 1, 3	2.5	7.5	S
Turn-on Delay Time	$t_{d(on)}$	3459	$I_D=-4.1A$ $V_{DD}=-42V$ Notes 3, 4	-	60	ns
Rise Time	t_r	3459	$I_D=-4.1A$ $V_{DD}=-42V$ Notes 3, 4	-	140	ns
Turn-off Delay Time	$t_{d(off)}$	3459	$I_D=-4.1A$ $V_{DD}=-42V$ Notes 3, 4	-	140	ns
Fall Time	t_f	3459	$I_D=-4.1A$ $V_{DD}=-42V$ Notes 3, 4	-	140	ns
Small-Signal Common-Source Short-Circuit Input Capacitance	C_{iss}	3431	$V_{DS}=-25V$ $V_{GS}=0V$ $f=1MHz$ Note 3	500	950	pF

Characteristics	Symbols	MIL-STD-750 Test Method	Test Conditions	Limits		Units
				Min	Max	
Small-Signal Common-Source Short-Circuit Output Capacitance	C_{oss}	-	$V_{DS}=-25V$ $V_{GS}=0V$ $f=1MHz$ Notes 3, 5	150	450	pF
Small-Signal Common-Source Short-Circuit Reverse Transfer Capacitance	C_{rss}	3433	$V_{DS}=-25V$ $V_{GS}=0V$ $f=1MHz$ Note 3	50	200	pF

NOTES:

1. Pulsed measurement: Pulse Width $\leq 300\mu s$, Duty Cycle $\leq 2\%$.
2. $r_{DS(on)}$ and $V_{DS(on)}$ measurements shall be made no more than 2mm from the case.
3. For AC characteristics read and record measurements shall be performed on a sample of 32 components with 0 failures allowed. Alternatively a 100% inspection may be performed.
4. $t_{d(on)}$, t_r , $t_{d(off)}$ and t_f shall be measured using the following test circuit. The input waveform shall be supplied by a pulse generator with the following characteristics: $Z_{out} = 50\Omega$, Pulse Width $\leq 3s$, Period $\leq 1ms$, Amplitude = 0V to -10V. The input transition and drain voltage response detectors shall have rise and fall response times such that doubling these responses will not affect the results greater than the precision of measurement. The current through these detectors shall be sufficiently small so that doubling it does not affect the results greater than the precision of measurement.

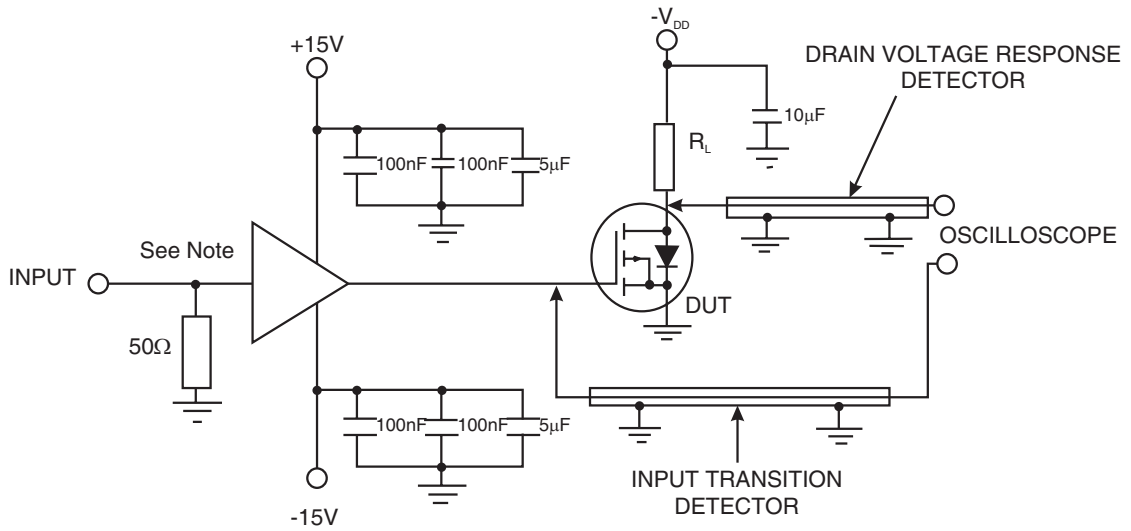

NOTE: The amplifier shall be a suitable voltage follower/buffer amplifier.

VOLTAGE WAVEFORMS

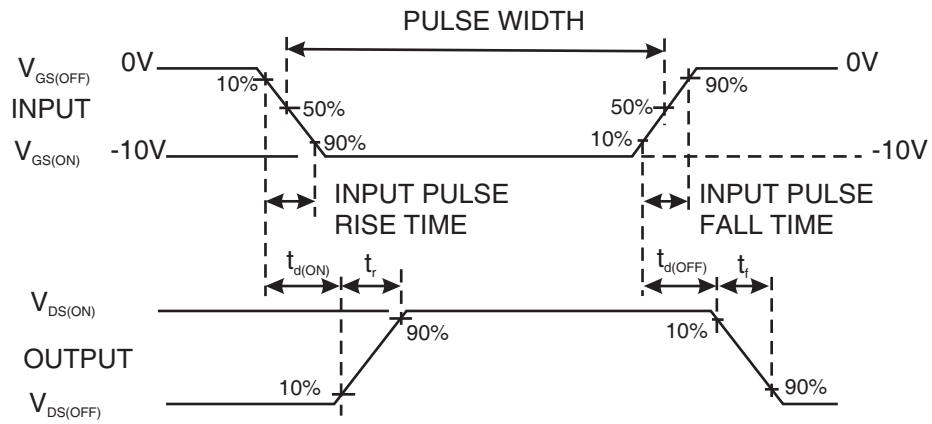

5. C_{oss} shall be measured using the test circuit shown below.

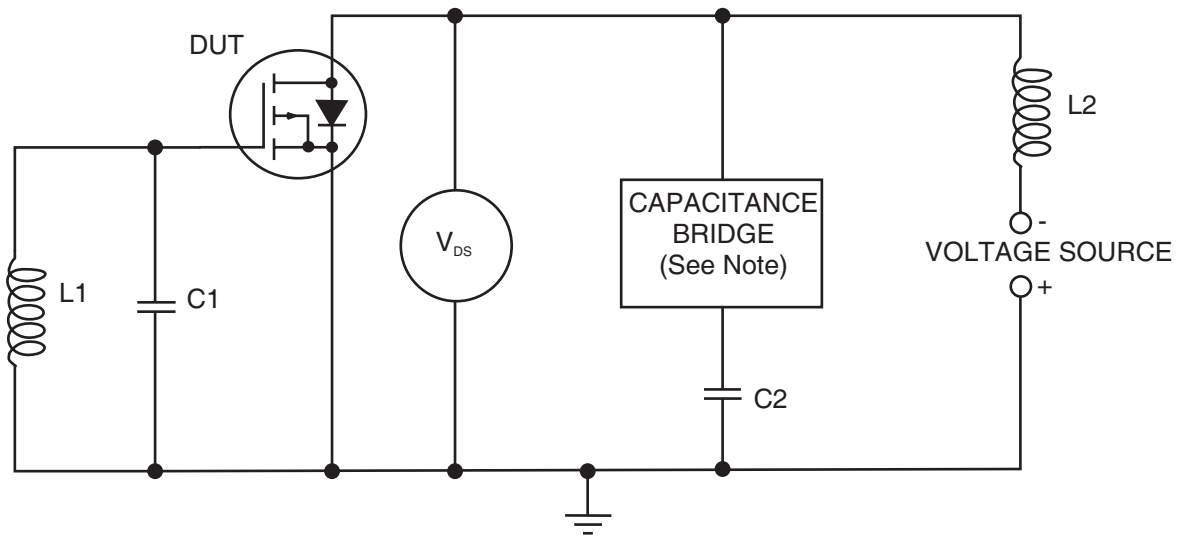

NOTE: The capacitance bridge shall have low DC resistance between its output terminals and should be capable of carrying the test current without affecting the desired accuracy of measurement.

2.6.2 High and Low Temperatures Electrical Measurements

Characteristics	Symbols	MIL-STD-750 Test Method	Test Conditions Note 1	Limits		Units
				Min	Max	
Gate-Source Threshold Voltage	$V_{GS(th)}$	3403	$V_{DS} \geq V_{GS}$ $I_D = -250\mu A$ $T_{amb} = +125(+0-5)^{\circ}C$ $T_{amb} = -55(+5-0)^{\circ}C$	-1 -	- -5	V
Gate-Body Leakage Current	I_{GSS}	3411	$T_{amb} = +125(+0-5)^{\circ}C$ $V_{GS} = -20V$ $V_{DS} = 0V$ Bias condition C	-	-200	nA
Drain Current	I_{DSS}	3413	$T_{amb} = +125(+0-5)^{\circ}C$ $V_{DS} = -80V$ $V_{GS} = 0V$ Bias condition C	-	-1	mA
Drain-Source On-state Resistance	$r_{DS(on)}$	3421	$T_{amb} = +125(+0-5)^{\circ}C$ $V_{GS} = -10V$ $I_D = -4.1A$ Test Condition A Notes 2, 3	-	540	mΩ

NOTES:

1. Read and record measurements shall be performed on a sample of 5 components with 0 failures

- allowed. Alternatively a 100% inspection may be performed.
2. Pulsed measurement: Pulse Width $\leq 300\mu\text{s}$, Duty Cycle $\leq 2\%$.
 3. $r_{\text{DS(on)}}$ measurements shall be made no more than 2mm from the case.

2.7 **PARAMETER DRIFT VALUES**

Unless otherwise specified, the measurements shall be performed at $T_{\text{amb}} = +22 \pm 3^\circ\text{C}$.

The test methods and test conditions shall be as per the corresponding test defined in Room Temperature Electrical Measurements.

The drift values (Δ) shall not be exceeded for each characteristic specified. The corresponding absolute limit values for each characteristic shall not be exceeded.

Characteristics	Symbols	Limits			Units
		Drift Value Δ	Absolute		
			Min	Max	
Gate-Source Threshold Voltage	$V_{\text{GS(th)}}$	$\pm 20\%$	-2	-4	V
Gate-Body Leakage Current	I_{GSS}	± 20 or (1) $\pm 100\%$	-	-100	nA
Drain Current	I_{DSS}	± 25 or (1) $\pm 100\%$	-	-250	μA
Drain-Source On-state Resistance	$r_{\text{DS(on)}}$	$\pm 20\%$	-	300	$\text{m}\Omega$

NOTES:

1. Whichever is the greater referred to the initial value.

2.8 **INTERMEDIATE AND END-POINT ELECTRICAL MEASUREMENTS**

Unless otherwise specified, the measurements shall be performed at $T_{\text{amb}} = +22 \pm 3^\circ\text{C}$.

The test methods and test conditions shall be as per the corresponding test defined in Room Temperature Electrical Measurements.

The limit values for each characteristic shall not be exceeded.

Characteristics	Symbols	Limits		Units
		Min	Max	
Gate-Source Threshold Voltage	$V_{\text{GS(th)}}$	-2	-4	V
Gate-Body Leakage Current	I_{GSS}	-	-100	nA
Drain Current	I_{DSS}	-	-250	μA

2.9 HIGH TEMPERATURE REVERSE BIAS BURN-IN CONDITIONS
MIL-STD-750, Test Method 1039, Condition A.

Characteristics	Symbols	Test Conditions	Units
Ambient Temperature	T_{amb}	+150(+0-5)	°C
Drain-Source Voltage	V_{DS}	80	V
Gate-Source Voltage	V_{GS}	0	V
Duration	t	72 minimum	hours

NOTES:

- High temperature reverse bias burn-in shall be performed using the circuit shown below.

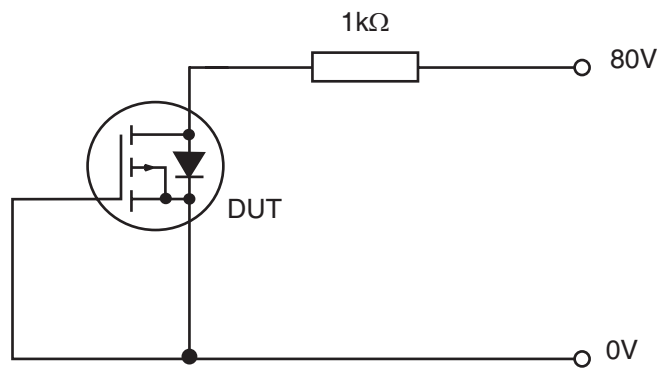

2.10 POWER BURN-IN CONDITIONS
MIL-STD-750, Test Method 1039, Condition B.

Characteristics	Symbols	Test Conditions	Units
Junction Temperature	T_J	Note 1	°C
Drain-Source Voltage	V_{DS}	Note 1	V
Gate-Source Voltage	V_{GS}	-1 to -16	V
Duration	t	240 minimum	hours

NOTES:

- Using the circuit shown below, power shall be applied to the device to achieve a junction temperature of $+140 \pm 10^\circ\text{C}$. The junction temperature shall be calculated as follows:
 $T_J(^{\circ}\text{C}) = V_{DS}(\text{V}) \times I_D(\text{A}) \times R_{th(j-c)}(^{\circ}\text{C}/\text{W}) + T_{case} (^{\circ}\text{C})$, where
 $V_{DS} = -10\text{V}$,
 $R_{th(j-c)} = 5^{\circ}\text{C}/\text{W}$,
 T_{case} is the highest temperature recorded on the case at any point during the test, and
 I_D = as required, but not exceeding the limits given in Maximum Ratings.

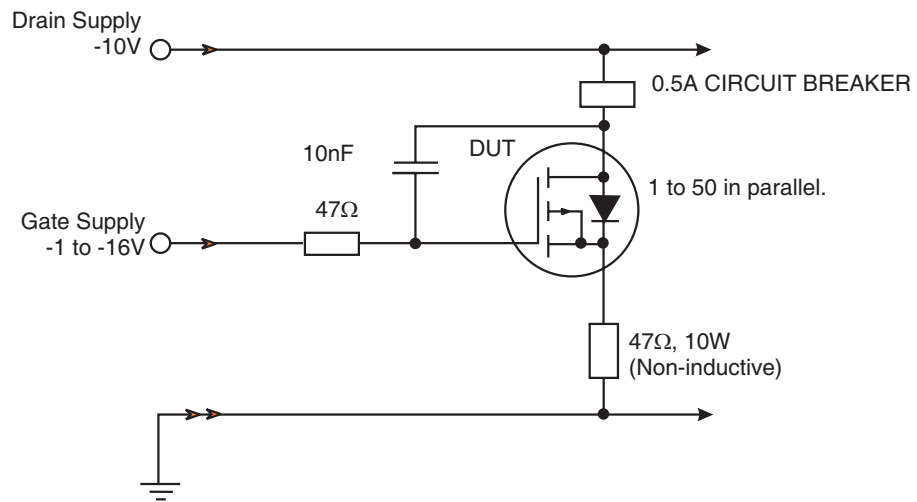

2.11 OPERATING LIFE CONDITIONS

The conditions shall be as specified for Power Burn-in.