



**TRANSISTORS, MICROWAVE, FIELD EFFECT,  
LOW NOISE AND GENERAL PURPOSE, GALLIUM  
ARSENIDE**

**BASED ON TYPES CFY25 AND CFY27**

**ESCC Detail Specification No. 5613/008**

Issue 3	April 2014
---------	------------



### **LEGAL DISCLAIMER AND COPYRIGHT**

European Space Agency, Copyright © 2014. All rights reserved.

The European Space Agency disclaims any liability or responsibility, to any person or entity, with respect to any loss or damage caused, or alleged to be caused, directly or indirectly by the use and application of this ESCC publication.

This publication, without the prior permission of the European Space Agency and provided that it is not used for a commercial purpose, may be:

- copied in whole, in any medium, without alteration or modification.
- copied in part, in any medium, provided that the ESCC document identification, comprising the ESCC symbol, document number and document issue, is removed.

**DOCUMENTATION CHANGE NOTICE**

(Refer to <https://escies.org> for ESCC DCR content)

DCR No.	CHANGE DESCRIPTION
849	Specification upissued to incorporate editorial changes per DCR.

**TABLE OF CONTENTS**

1	GENERAL	6
1.1	SCOPE	6
1.2	COMPONENT TYPE VARIANTS	6
1.3	MAXIMUM RATINGS	6
1.4	PARAMETER DERATING INFORMATION	6
1.5	PHYSICAL DIMENSIONS	6
1.6	FUNCTIONAL DIAGRAM	6
1.7	HANDLING PRECAUTIONS	6
2	APPLICABLE DOCUMENTS	6
3	TERMS, DEFINITIONS, ABBREVIATIONS, SYMBOLS AND UNITS	10
4	REQUIREMENTS	11
4.1	GENERAL	11
4.2	DEVIATIONS FROM GENERIC SPECIFICATION	11
4.2.1	Deviations from Production Control	11
4.2.2	Deviations from Final Production Tests (Chart II(b))	11
4.2.3	Deviations from Burn-in and Electrical Measurements (Chart III(b))	11
4.2.4	Deviations from Qualification Tests (Chart IV)	11
4.2.5	Deviations from Lot Acceptance Tests (Chart V)	11
4.3	MECHANICAL REQUIREMENTS	12
4.3.1	Dimension Check	12
4.3.2	Weight	12
4.3.3	Terminal Strength	12
4.3.4	Bond Strength	12
4.3.5	Die Shear	12
4.4	MATERIALS AND FINISHES	12
4.4.1	Case	12
4.4.2	Lead Material and Finish	13
4.5	MARKING	13
4.5.1	General	13
4.5.2	Terminal Identification	13
4.5.3	The ESCC Component Number	13
4.5.4	Traceability Information	13
4.6	ELECTRICAL MEASUREMENTS	13
4.6.1	Electrical Measurements at Room Temperature	13
4.6.2	Electrical Measurements at High and Low Temperatures	13

4.6.3	Circuits for Electrical Measurements	14
4.7	BURN-IN TESTS	14
4.7.1	Parameter Drift Values	14
4.7.2	Conditions for High Temperature Reverse Bias Burn-in	14
4.7.3	Conditions for Power Burn-in	14
4.7.4	Electrical Circuit for High Temperature Reverse Bias Burn-in	14
4.7.5	Electrical Circuit for Power Burn-in	14
4.8	ENVIRONMENTAL AND ENDURANCE TESTS (CHARTS IV AND V OF ESCC GENERIC SPECIFICATION NO. 5010)	14
4.8.1	Electrical Measurements on Completion of Environmental Tests	14
4.8.2	Electrical Measurements at Intermediate Points and on Completion of Endurance Tests	14
4.8.3	Conditions for Operating Life Test (Part of Endurance Testing)	14
4.8.4	Electrical Circuit for Operating Life Test	14
4.9	TOTAL DOSE IRRADIATION TESTING	15
4.10	SPECIAL TESTING	15
	APPENDIX 'A'	25

## 1 GENERAL

### 1.1 SCOPE

This specification details the ratings, physical and electrical characteristics, test and inspection data for a Transistor, Microwave, Field Effect, Low Noise and General Purpose, Gallium Arsenide, Based on Types CFY25 and CFY27. It shall be read in conjunction with ESCC Generic Specification No. 5010, the requirements of which are supplemented herein.

### 1.2 COMPONENT TYPE VARIANTS

Variants of the basic type components specified herein, which are also covered by this specification, are given in Table 1(a).

### 1.3 MAXIMUM RATINGS

The maximum ratings, which shall not be exceeded at any time during use or storage, applicable to the components specified herein, are as scheduled in Table 1(b).

### 1.4 PARAMETER DERATING INFORMATION

The derating information applicable to the components specified herein is shown in Figure 1.

### 1.5 PHYSICAL DIMENSIONS

The physical dimensions of the components specified herein are shown in Figure 2.

### 1.6 FUNCTIONAL DIAGRAM

The functional diagram, showing lead identification of the components specified herein, is shown in Figure 3.

### 1.7 HANDLING PRECAUTIONS

These devices are susceptible to damage by electrostatic discharge. Therefore suitable precautions shall be employed for protection during all phases of manufacture, test, packaging, shipping and handling.

These components are categorised as follows:

- Variants 01 and 02 (CFY27) - Class 1 with a Minimum Critical Path Failure Voltage of 750V.
- Variants 03 to 07 (CFY25) - Class 1 with a Minimum Critical Path Failure Voltage of 250V.

## 2 APPLICABLE DOCUMENTS

The following documents form part of this specification and shall be read in conjunction with it:

- (a) ESCC Generic Specification No. 5010 for Discrete Microwave Semiconductor Components.
- (b) MIL-STD-750, Test Methods for Semiconductor Devices.

**TABLE 1(a) - TYPE VARIANTS**

(1) Variant	(2) Based on Type	(3) Case	(4) Figure	(5) Noise Figure @ 12 GHz $NF_{min}$ (dB)	(6) Associated Gain @ 12 GHz $G_a$ (dB)	(7) Output Power @ 12 GHz $P_{-1dB}$ (dB)	(8) Linear Gain @ 12 GHz $G_{lp}$ (dB)	(9) Lead Material and Finish
01	CFY27-38	Micro-X	2	$\leq 3.8$	$\geq 7.5$	N/A	N/A	D2
02	CFY27-P	Micro-X	2	N/A	N/A	$\geq 24.5$ (Note 1)	$\geq 17.5$ (Note 1)	D2
03	CFY25-20P	Micro-X	2	$\leq 2.1$	$\geq 8.5$	$\geq 14$	$\geq 8.5$	D2
04	CFY25-20	Micro-X	2	$\leq 2.1$	$\geq 8.5$	N/A	N/A	D2
05	CFY25-23P	Micro-X	2	$\leq 2.4$	$\geq 8$	$\geq 14$	$\geq 8$	D2
06	CFY25-23	Micro-X	2	$\leq 2.4$	$\geq 8$	N/A	N/A	D2
07	CFY25-P	Micro-X	2	N/A	N/A	$\geq 14$	$\geq 8.5$	D2

**NOTES:**

1.  $P_{-1dB}$  and  $G_{lp}$  for Variant 02 measured at 2.3 GHz.

**TABLE 1(b) - MAXIMUM RATINGS**

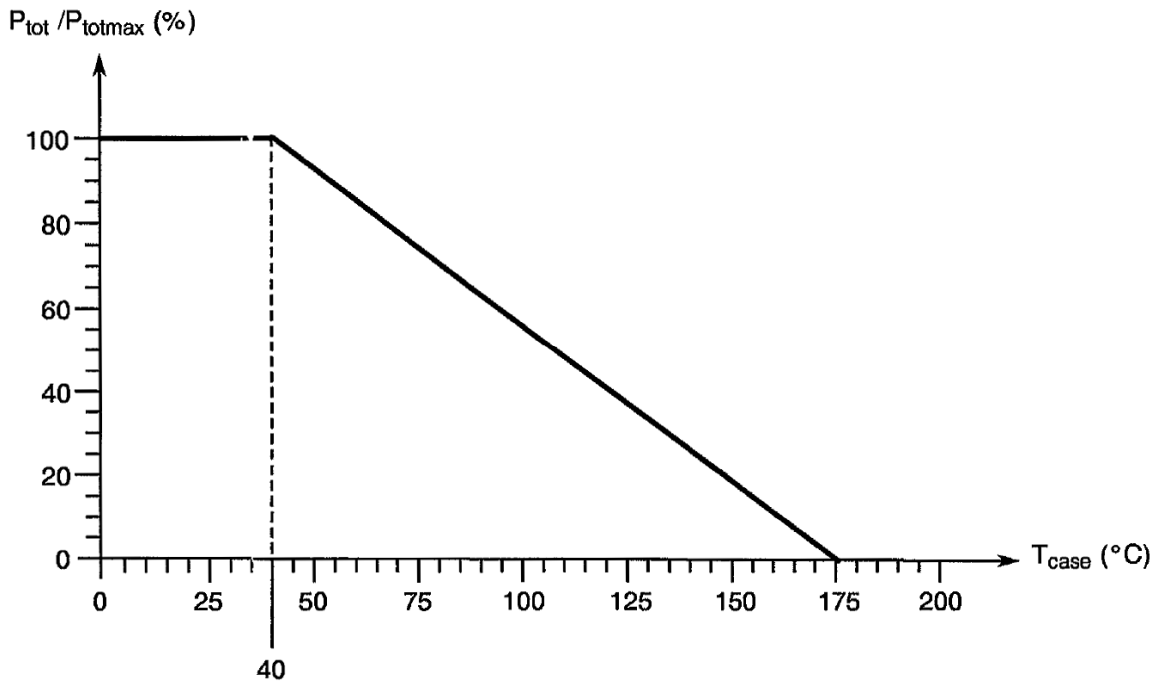
No.	Characteristics	Symbol	Maximum Ratings	Unit	Remarks
1	Drain-Source Voltage Variants 01 and 02 Variants 03 to 07	$V_{DS}$	9 5	V	
2	Drain-Gate Voltage Variants 01 and 02 Variants 03 to 07	$V_{DG}$	11 7	V	
3	Gate-Source Voltage Variants 01 and 02 Variants 03 to 07	$V_{GS}$	-6 to +0.5 -5 to +0.5	V	
4	Drain Current Variants 01 and 02 Variants 03 to 07	$I_D$	385 at $V_{DS} < 2V$ 80 at $V_{DS} < 4.1V$	mA	Note 1
5	Operational Gate Current Variants 01 and 02 Variants 03 to 07	$I_{Go}$	5 1.5	mA	
6	RF Input Power, X-Band Variants 01 and 02 Variants 03 to 07	$P_{RFIn}$	21 at $V_{DS} \leq 5V$ 17 at $V_{DS} \leq 3.5V$	dBm	Note 2
7	Compression Level Variants 01 and 02 Variants 03 to 07	$P_c$	4 at $V_{DS} \leq 5V, 80mA < I_D < 140mA$ 4 at $V_{DS} \leq 3.5V, 15mA < I_D < 30mA$	dB	Note 2
8	Power Dissipation Variants 01 and 02 Variants 03 to 07	$P_{tot}$	770 330	mW	Note 1
9	Channel Temperature Range	$T_{ch}$	-65 to +175	°C	

No.	Characteristics	Symbol	Maximum Ratings	Unit	Remarks
10	Storage Temperature Range	$T_{stg}$	-65 to +175	°C	
11	Soldering Temperature	$T_{sol}$	+230	°C	Note 3

**NOTES:**

1. At  $T_{case} = +40$  °C. For derating at  $T_{case} > +40$  °C, see Figure 1.
2. Under continuous wave.
3. Duration 15 seconds maximum for the leads. The same termination shall not be resoldered until 3 minutes have elapsed.

**FIGURE 1 - PARAMETER DERATING INFORMATION**



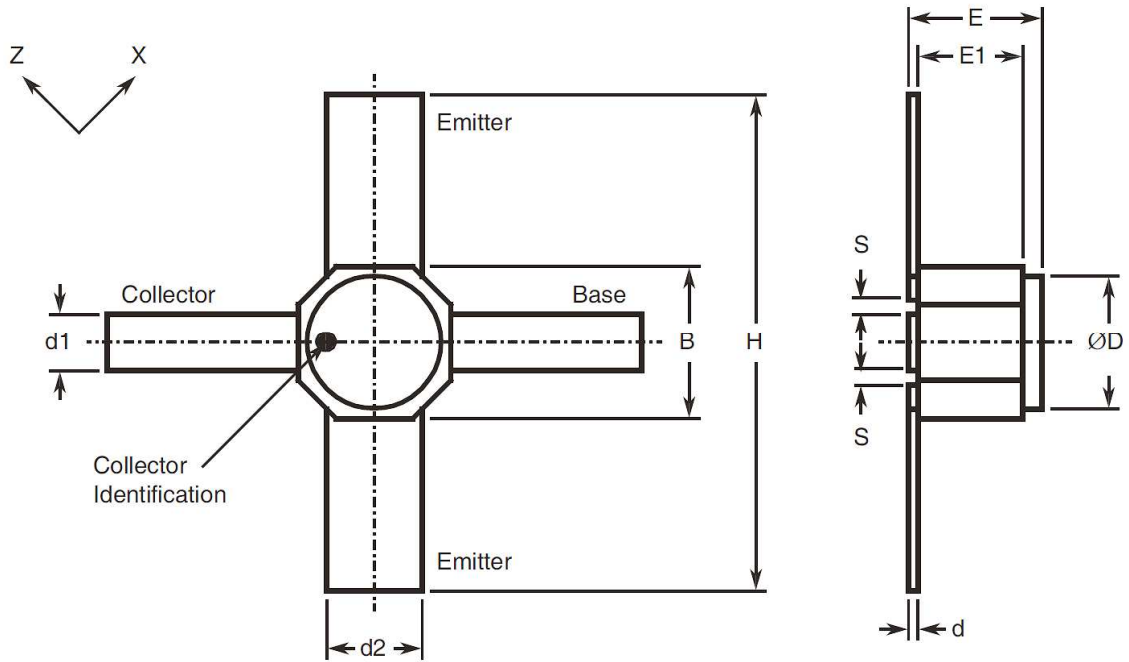
Power Dissipation versus Temperature

**NOTES:**

1. Thermal Resistance ( $R_{TH(ch-s)}$ )
  - Variants 01 and 02: 175 °C/W.
  - Variants 03 to 07: 410 °C/W.

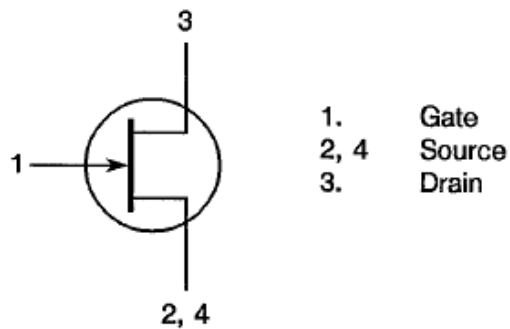


**FIGURE 2 - PHYSICAL DIMENSIONS**



Symbol	Millimetres	
	Min.	Max.
B	1.68	1.88
d	0.07	0.15
d1	0.4	0.6
d2	0.92	1.12
ØD	1.55	1.85
E	0.85	1.25
E1	0.66	0.86
H	4	4.4
S	0.08	0.3

**FIGURE 3 - FUNCTIONAL DIAGRAM**



**NOTES:**

1. The gate is marked with a black dot.

### 3 TERMS, DEFINITIONS, ABBREVIATIONS, SYMBOLS AND UNITS

For the purpose of this specification, the terms, definitions, abbreviations, symbols and units specified in ESCC Basic Specification No. 21300 shall apply. In addition, the following symbols are used:

D	=	Drain.
G	=	Gate.
$G_{lp}$	=	Linear (small signal) Gain for Power Matching Condition.
$G_p$	=	Power Gain for Power Matching Condition.
$g_m$	=	Transconductance.
$I_D$	=	Drain Current.
$I_{Dpl, h}$	=	Drain Leakage Current at Pinch-off (l: at low voltages, h: at high voltages).
$I_{Dq}$	=	Drain Quiescent Current (Drain Operational Current without RF Excitation).
$I_{DSS}$	=	Drain Saturation Current for Shorted Gate ( $V_{GS} = 0$ ).
$I_G$	=	Gate Current.
$I_{Go}$	=	Gate DC Current under RF (Gate Operational Mean Current under RF Excitation).
$I_{Gpl, h}$	=	Gate Leakage Current at Pinch-off (l: at low voltages, h: at high voltages).
$P_c$	=	Power Gain Compression Level.
$P_{DC}$	=	Dissipated DC Power.
$P_{in}$	=	RF Input Power.
$P_{out}$	=	RF Output Power.
$P_{tot}$	=	Power Dissipation (= $P_{DC} + P_{in} - P_{out}$ ).
$P_{-1dB}$	=	Output Power at 1dB Gain Compression.
$R_D$	=	External Drain Resistance.
$R_G$	=	External Gate Resistance.
$R_S$	=	External Source Resistance.
$R_{TH(ch-s)}$	=	Thermal Resistance, Channel to Soldering Point.
$R_{TH(S-A)}$	=	Thermal Resistance, Soldering Point to Ambient.
S	=	Source.
$V_{DD}$	=	Output Voltage from Drain Power Supply.
$V_{DG}$	=	Drain-Gate Voltage.
$V_{DS}$	=	Drain-Source Voltage.
$V_{GG}$	=	Output Voltage from Gate Power Supply.
$V_{GS}$	=	Gate-Source Voltage.
$V_{GSth}$	=	Gate-Source Threshold Voltage (Turn-on Voltage).
$V_{SS}$	=	Output Voltage from Source Power Supply (Ground).

## 4 REQUIREMENTS

### 4.1 GENERAL

The complete requirements for procurement of the components specified herein shall be as stated in this specification and ESCC Generic Specification No. 5010 for Discrete Microwave Semiconductor Components. Deviations from the Generic Specification, applicable to this specification only, are listed in Para. 4.2.

Deviations from the applicable Generic Specification and this Detail Specification, formally agreed with specific Manufacturers on the basis that the alternative requirements are equivalent to the ESCC requirements and do not affect the components' reliability, are listed in the appendices attached to this specification.

### 4.2 DEVIATIONS FROM GENERIC SPECIFICATION

#### 4.2.1 Deviations from Production Control

None.

#### 4.2.2 Deviations from Final Production Tests (Chart II(b))

- (a) Para. 9.5, Thermal Shock: May also be performed in accordance with MIL-STD-883, Test Method 1010.1, Test Condition C.
- (b) Para. 9.7, Particle Impact Noise Detection (PIND) Test: May be performed at any point after the position indicated in Chart II(b), but before final seal test, gross leak and fine leak.

#### 4.2.3 Deviations from Burn-in and Electrical Measurements (Chart III(b))

- (a) Para. 9.9.2, Table 3 measurements: May be performed at any stage after power burn-in.
- (b) Para. 9.9.3, Table 2 measurements: May be performed at any stage after power burn-in.

#### 4.2.4 Deviations from Qualification Tests (Chart IV)

- (a) Paras. 9.8.1 and 9.8.2, Seal Test: The tests following Para. 9.15, Constant Acceleration shall not be performed.
- (b) Para. 9.13, Shock Test: Shall not be performed.
- (c) Para. 9.14, Vibration Test: Shall not be performed.
- (d) Para. 9.15, Constant Acceleration: Shall not be performed.
- (e) Para. 9.23, Special Testing: Shall not be performed.
- (f) Assembly/Capability tests (Subgroup II): In addition to the permitted electrical rejects, components rejected from radiographic inspection, seal test or external visual inspection may also be used for these tests, if they are considered capable of passing the Assembly/Capability test sequence.

#### 4.2.5 Deviations from Lot Acceptance Tests (Chart V)

- (a) Paras. 9.8.1 and 9.8.2, Seal Test: The tests following Para. 9.15, Constant Acceleration shall not be performed.
- (b) Para. 9.13, Shock Test: Shall not be performed.
- (c) Para. 9.14, Vibration Test: Shall not be performed.
- (d) Para. 9.15, Constant Acceleration: Shall not be performed.
- (e) Para. 9.23, Special Testing: Shall not be performed.
- (f) Assembly/Capability tests (Subgroup II): In addition to the permitted electrical rejects, components rejected from radiographic inspection, seal test or external visual inspection may also be used for these tests, if they are considered capable of passing the Assembly/Capability test sequence.

### 4.3 MECHANICAL REQUIREMENTS

#### 4.3.1 Dimension Check

The dimensions of the components specified herein shall be checked. They shall conform to those shown in Figure 2.

#### 4.3.2 Weight

The maximum weight of the components specified herein shall be 0.03 grammes.

#### 4.3.3 Terminal Strength

The requirements for terminal strength testing are specified in Section 9 of ESCC Generic Specification No. 5010. The test conditions shall be as follows:

- Condition: 'A' (Tension).
- Force: 2.2N.
- Duration: 5 seconds.

#### 4.3.4 Bond Strength

The requirements for bond strength are specified in Section 9 of ESCC Generic Specification No. 5010. The test conditions shall be as follows:

- Condition: 'P'.
- Bond Strength:  
Variants 01 and 02: 0.03N force minimum at pre-seal tests, 0.025N force minimum at post-seal tests.  
Variants 03 to 07: 0.015N force minimum at pre-seal tests, 0.012N force minimum at post-seal tests.

#### 4.3.5 Die Shear

The requirements for die shear are specified in Section 9 of ESCC Generic Specification No. 5010. The test conditions shall be alternatively as follows:

- Minimum acceptable die shear strengths:  
Variants 01 and 02: 1.6N.  
Variants 03 to 07: 0.7N.
- In those cases where the clearances in the package do not allow application of the die shear force with a suitable tool, the chip shall be pushed away with a suitable tool and the die attach area inspected afterwards.
- Sufficient die attach quality is achieved if objective evidence for sufficient mechanical and thermal contact is found, i.e. more than 50% semiconductor material remains.

### 4.4 MATERIALS AND FINISHES

The materials and finishes shall be as specified herein. Where a definite material is not specified, a material which will enable the components specified herein to meet the performance requirements of this specification shall be used. Acceptance or approval of any constituent material does not guarantee acceptance of the finished product.

#### 4.4.1 Case

The case shall be hermetically sealed and have a ceramic body.

#### 4.4.2 Lead Material and Finish

The lead material shall be Type 'D' with Type '2' finish in accordance with the requirements of ESCC Basic Specification No. 23500.

#### 4.5 MARKING

##### 4.5.1 General

The marking of components delivered to this specification shall be in accordance with the requirements of ESCC Basic Specification No. 21700 and the following paragraphs. When the component is too small to accommodate all of the marking as specified, as much as space permits shall be marked and the marking information, in full, shall accompany the component in its primary package.

The information to be marked and the order of precedence, shall be as follows:

- (a) Terminal Identification.
- (b) The ESCC Component Number.
- (c) Traceability Information.

The primary package shall bear an "ESD sensitive" label.

##### 4.5.2 Terminal Identification

Terminal identification shall be as shown in Figures 2 and 3 of this specification.

##### 4.5.3 The ESCC Component Number

Each component shall bear the ESCC Component Number which shall be constituted and marked as follows:

Example: 561300801B

- Detail Specification Number: 5613008
- Type Variant (see Table 1(a)): 01
- Testing Level (B or C, as applicable): B

##### 4.5.4 Traceability Information

Each component shall be marked in respect of traceability information in accordance with the requirements of ESCC Basic Specification No. 21700.

#### 4.6 ELECTRICAL MEASUREMENTS

##### 4.6.1 Electrical Measurements at Room Temperature

The parameters to be measured at room temperature are scheduled in Table 2. Unless otherwise specified, the measurements shall be performed at  $T_{amb} = +25 \pm 3$  °C.

Within their part types, those components which fail to achieve their specified RF Classification may be assigned to another type variant, after final electrical measurements.

##### 4.6.2 Electrical Measurements at High and Low Temperatures

The parameters to be measured at high and low temperatures are scheduled in Table 3. Unless otherwise specified, the measurements shall be performed at  $T_{amb} = +140 (+0 -5)$  °C.

#### 4.6.3 Circuits for Electrical Measurements

Circuits for use in performing electrical measurements listed in Tables 2 and 3 of this specification are shown in Figure 4.

#### 4.7 BURN-IN TESTS

Burn-in shall be to Chart III(b) of ESCC Generic Specification No. 5010.

##### 4.7.1 Parameter Drift Values

The parameter drift values applicable to burn-in are specified in Table 4 of this specification. Unless otherwise stated, measurements shall be performed at  $T_{amb} = +25 \pm 3$  °C. The parameter drift values ( $\Delta$ ) applicable to the scheduled parameters shall not be exceeded. In addition to these drift value requirements, the appropriate limit value specified for a given parameter in Table 2 shall not be exceeded.

##### 4.7.2 Conditions for High Temperature Reverse Bias Burn-in

The requirements for high temperature reverse bias burn-in are specified in Section 9 of ESCC Generic Specification No. 5010. The conditions for high temperature reverse bias burn-in shall be as specified in Table 5(a) of this specification.

##### 4.7.3 Conditions for Power Burn-in

The requirements for power burn-in are specified in Section 9 of ESCC Generic Specification No. 5010. The conditions for power burn-in shall be as specified in Table 5(b) of this specification.

##### 4.7.4 Electrical Circuit for High Temperature Reverse Bias Burn-in

The circuit for use in performing the high temperature reverse bias burn-in test is the general burn-in circuit shown in Figure 5 of this specification.

##### 4.7.5 Electrical Circuit for Power Burn-in

The circuit for use in performing the power burn-in test is shown in Figure 5 of this specification.

#### 4.8 ENVIRONMENTAL AND ENDURANCE TESTS (CHARTS IV AND V OF ESCC GENERIC SPECIFICATION NO. 5010)

##### 4.8.1 Electrical Measurements on Completion of Environmental Tests

The parameters to be measured on completion of environmental tests are scheduled in Table 2. Unless otherwise stated, the measurements shall be performed at  $T_{amb} = +25 \pm 3$  °C.

##### 4.8.2 Electrical Measurements at Intermediate Points and on Completion of Endurance Tests

The parameters to be measured at intermediate points and on completion of endurance testing are as scheduled in Table 6 of this specification. Unless otherwise stated, the measurements shall be performed at  $T_{amb} = +25 \pm 3$  °C.

##### 4.8.3 Conditions for Operating Life Test (Part of Endurance Testing)

The requirements for operating life testing are specified in Section 9 of ESCC Generic Specification No. 5010. The conditions for operating life testing shall be as specified in Table 5(b) of this specification.

##### 4.8.4 Electrical Circuit for Operating Life Test

The circuit for use in performing the operating life test shall be the same as shown in Figure 5 of this specification for power burn-in.

4.9 TOTAL DOSE IRRADIATION TESTING

Not applicable.

4.10 SPECIAL TESTING

Not applicable.

**TABLE 2 - ELECTRICAL MEASUREMENTS AT ROOM TEMPERATURE - DC PARAMETERS**

No.	Characteristics	Symbol	Test Fig.	Test Conditions	Limits		Unit
					Min.	Max.	
1	Drain Leakage Current at Pinch-off 1 (high $V_{DS}$ )	$I_{Dph}$	4(a)	$V_{DS} = -4V$ Variants 01 and 02: $V_{DS} = 7V$ Variants 03 to 07: $V_{DS} = 3V$	-	480	$\mu A$
2	Gate Leakage Current at Pinch-off 1 (high $V_{DS}$ )	$I_{Gph}$	4(a)	$V_{DS} = -4V$ Variants 01 and 02: $V_{DS} = 7V$ Variants 03 to 07: $V_{DS} = 3V$	-	-240	$\mu A$
3	Drain Leakage Current at Pinch-off 2 (low $V_{DS}$ )	$I_{Dpl}$	4(a)	$V_{DS} = -3.5V$ Variants 01 and 02: $V_{DS} = 3V$ Variants 03 to 07:	-	96	$\mu A$
4	Gate Leakage Current at Pinch-off 2 (low $V_{DS}$ )	$I_{Gpl}$	4(a)	$V_{DS} = -3.5V$ Variants 01 and 02: $V_{DS} = 3V$ Variants 03 to 07:	-	N/A	$\mu A$
5	Drain Saturation Current	$I_{DSS}$	4(a)	$V_{DS} = 0V$ Variants 01 and 02: $V_{DS} = 2V$ Variants 03, 05, 07: $V_{DS} = 3V$ Variants 04, 06: $V_{DS} = 3V$	150 25 15	385 60 60	mA
6	Gate-Source Threshold Voltage	$V_{GSth}$	4(a)	$V_{DS} = 3V$ Variants 01 and 02: $I_D = 12mA$ Variants 03 to 07: $I_D = 1mA$	-0.9 -0.3	-3.2 -3	V
7	Transconductance	$g_m$	4(a)	$V_{DS} = 3V$ Variants 01 and 02: $I_D = 120mA$ Variants 03 to 07: $I_D = 15mA$	130 35	- -	mS
8	Gate Quiescent Bias Current	$I_{Gq}$	4(a)	$V_{DS} = 3V$ Variants 01 and 02: Variants 03 to 07: $I_D = 15mA$	- -	N/A -2	$\mu A$

**TABLE 2 - ELECTRICAL MEASUREMENTS AT ROOM TEMPERATURE - AC PARAMETERS**

No.	Characteristics	Symbol	Test Fig.	Test Conditions	Limits		Unit
					Min.	Max.	
9	Noise Figure (Note 1)	$N_{Fmin}$	4(b)	$V_{DS} = 3V, f = 12 GHz$ Variant 01: $I_{Dq} = 120mA$ Variants 03 to 06: $I_{Dq} = 15mA$ Variants 02, 07:	- - -	Note 2 Note 2 N/A	dB
10	Associated Gain (Note 1)	$G_a$	4(b)	$V_{DS} = 3V, f = 12 GHz$ Variant 01: $I_{Dq} = 120mA$ Variants 03 to 06: $I_{Dq} = 15mA$ Variants 02, 07:	Note 3 Note 3 N/A	- - -	dB

No.	Characteristics	Symbol	Test Fig.	Test Conditions	Limits		Unit
					Min.	Max.	
11	Output Power at 1dB Gain Compression (Note 4)	$P_{-1dB}$	4(c)	Variant 02: $V_{DS} = 5V, f = 2.3 \text{ GHz}, I_{Dq} = 120\text{mA}$ Variants 03, 05, 07: $V_{DS} = 3V, f = 12\text{GHz}, I_{Dq} = 20\text{mA}$ Variants 01, 04, 06	Note 5 Note 5 N/A	- - -	dBm
12	Linear Power Gain, $P_{in} = 0\text{dBm}$ (Note 4)	$g_{ip}$	4(c)	Variant 02: $V_{DS} = 5V, f = 2.3 \text{ GHz}, I_{Dq} = 120\text{mA}$ Variants 03, 05, 07: $V_{DS} = 3V, f = 12 \text{ GHz}, I_{Dq} = 20\text{mA}$ Variants 01, 04, 06	Note 6 Note 6 N/A	- - -	dB
13	S-Parameters (Note 7)	$S_{11},$ $S_{21},$ $S_{12},$ $S_{22}$	4(d)	$V_{DS} = 3V, f = 1 \text{ to } 15 \text{ GHz}$ Variants 01 and 02: $I_{Dq} = 120\text{mA}$ Variants 03 to 07: $I_{Dq} = 15\text{mA}$	(Note 8)		Mag, Ang

**NOTES:**

1. Input and output matched for minimum Noise Figure.
2. See Column 5 of Table 1(a).
3. See Column 6 of Table 1(a).
4. Input and output matched for maximum  $P_{-1dB}$ .
5. See Column 7 of Table 1(a).
6. See Column 8 of Table 1(a).
7. Under matched condition ( $Z = 50\Omega$ ). Shall be performed on 4 assembled samples per wafer after Burn-in.
8. No specific limits applicable. The parameters are read and record for information only.

**TABLE 3 - ELECTRICAL MEASUREMENTS AT HIGH TEMPERATURE**

No.	Characteristics	Symbol	Test Fig.	Test Conditions	Limits		Unit
					Min.	Max.	
1	Drain Leakage Current at Pinch-off 1 (high $V_{DS}$ )	$I_{Dph}$	4(a)	See Table 2 Variants 01 and 02: Variants 03 to 07:	- -	2.4 1.5	mA
2	Gate Leakage Current at Pinch-off 1 (high $V_{DS}$ )	$I_{Gph}$	4(a)	See Table 2 Variants 01 and 02: Variants 03 to 07:	- -	-1.2 -1	mA
3	Drain Leakage Current at Pinch-off 2 (low $V_{DS}$ ) (Note 1)	$I_{Dpl}$	4(a)	See Table 2 Variants 01 and 02: Variants 03 to 07:	- -	0.48 N/A	mA
4	Gate Leakage Current at Pinch-off 2 (low $V_{DS}$ ) (Note 1)	$I_{Gpl}$	4(a)	See Table 2 Variants 01 and 02: Variants 03 to 07:	- -	-0.24 N/A	mA
6	Gate-Source Threshold Voltage (Note 1)	$V_{Gsth}$	4(a)	See Table 2 Variants 01 and 02: Variants 03 to 07:	-0.7 -0.2	-3.4 -3.2	V



No.	Characteristics	Symbol	Test Fig.	Test Conditions	Limits		Unit
					Min.	Max.	
7	Transconductance (Note 1)	$g_m$	4(a)	$V_{DS}$ see Table 2 Variants 01 and 02: $I_D = 54mA$ Variants 03 to 07: see Table 2	80 25	- -	mS

**NOTES:**

1. Shall be performed on 5 assembled samples per wafer. If a failure occurs, 100% measurements shall be performed.

**FIGURE 4 - CIRCUITS FOR ELECTRICAL MEASUREMENTS**

FIGURE 4(a) - TEST CIRCUIT FOR DC PARAMETERS

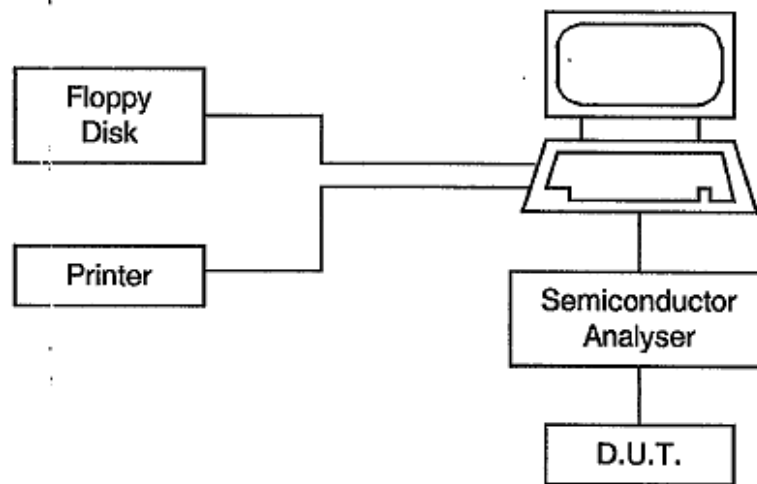


FIGURE 4(b) - TEST SET-UP FOR NOISE FIGURE MEASUREMENT

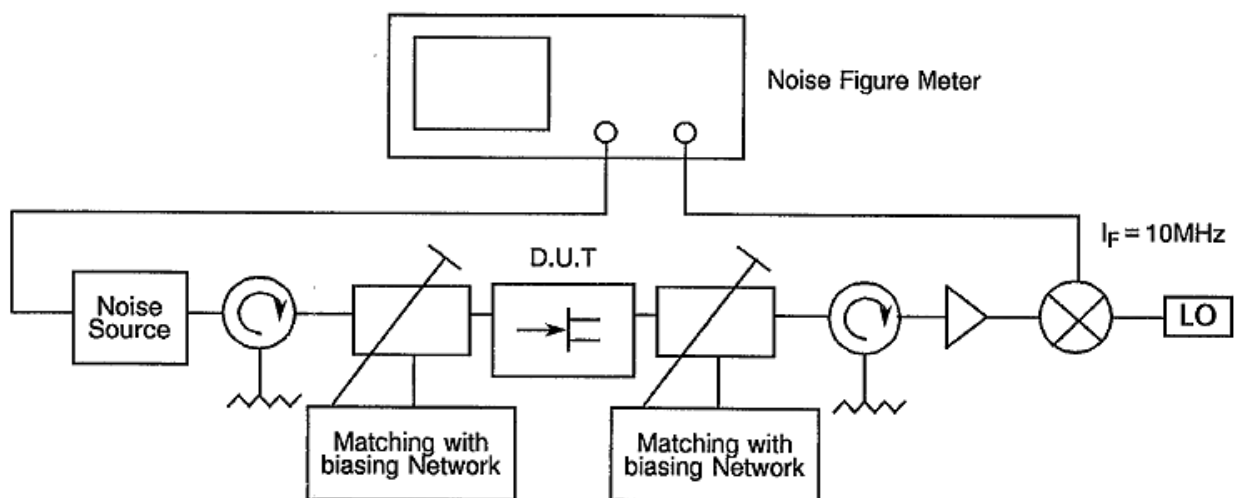


FIGURE 4(c) - TEST CIRCUIT FOR OUTPUT POWER MEASUREMENTS

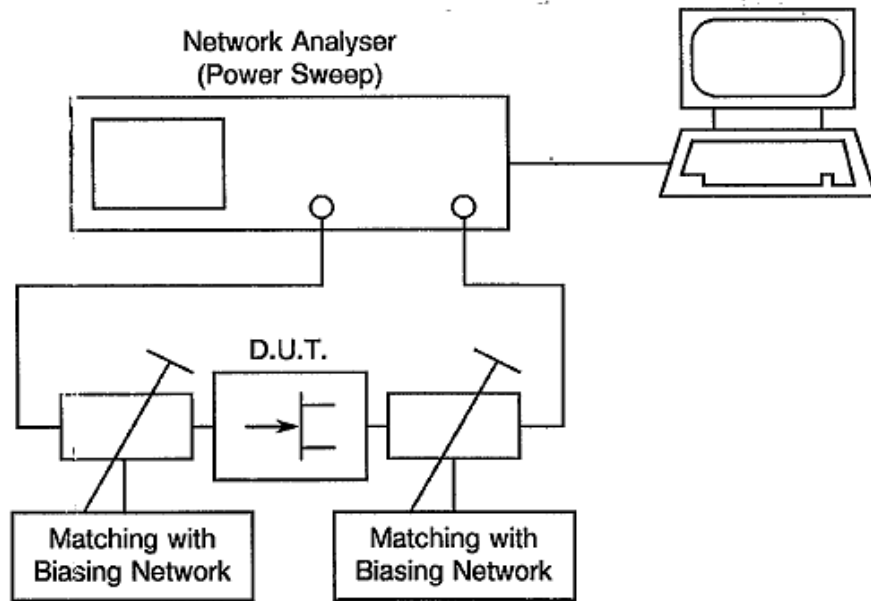
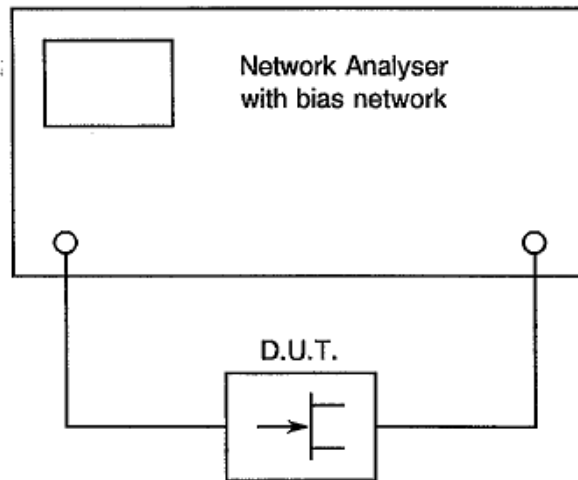


FIGURE 4(d) - TEST SET-UP FOR SCATTERING PARAMETER MEASUREMENTS



**TABLE 4 - PARAMETER DRIFT VALUES**

No.	Characteristics	Symbol	Test Fig.	Test Conditions	Change Limits ( $\Delta$ )	Unit
1	Drain Leakage Current at Pinch-off 1 (high $V_{DS}$ )	$I_{Dph}$	4(a)	See Table 2 Variants 01 and 02 Variants 03 to 07	N/A $\pm 150$	$\mu A$
2	Gate Leakage Current at Pinch-off 1 (high $V_{DS}$ )	$I_{Gph}$	4(a)	See Table 2 Variants 01 and 02 Variants 03 to 07	N/A $\pm 100$	$\mu A$
3	Drain Leakage Current at Pinch-off 2 (low $V_{DS}$ )	$I_{Dpl}$	4(a)	See Table 2 Variants 01 and 02 Variants 03 to 07	$\pm 48$ N/A	$\mu A$
4	Gate Leakage Current at Pinch-off 2 (low $V_{DS}$ )	$I_{Gpl}$	4(a)	See Table 2 Variants 01 and 02 Variants 03 to 07	$\pm 24$ N/A	$\mu A$
5	Drain Saturation Current	$I_{DSS}$	4(a)	See Table 2 Variants 01 and 02 Variants 03 to 07	$\pm 30$ $\pm 2.5$	mA
6	Gate Source Threshold Voltage	$V_{GSth}$	4(a)	See Table 2 Variants 01 and 02 Variants 03 to 07	$\pm 0.2$ $\pm 0.1$	V
7	Transconductance	$g_m$	4(a)	See Table 2 Variants 01 and 02 Variants 03 to 07	$\pm 18$ $\pm 2.5$	mS
9	Noise Figure (Note 1)	$NF_{min}$	4(b)	See Table 2 Variants 01, 03 to 06 Variants 02, 07	$\pm 0.15$ N/A	dB
10	Associated Gain (Note 1)	$G_a$	4(b)	See Table 2 Variants 01, 03 to 06 Variants 02, 07	$\pm 0.4$ N/A	dB
11	Output Power @ 1dB Gain Compression (Note 1)	$P_{-1dB}$	4(b)	See Table 2 Variants 01, 03 to 06 Variants 02, 07	N/A -0.2 / +0.5	dB
12	Linear Power Gain (Note 1)	$G_{lp}$	4(b)	See Table 2 Variants 01, 03 to 06 Variants 02, 07	N/A $\pm 0.4$	dB

**NOTES:**

1. Drift in RF-performance shall only be evaluated for completed burn-in, i.e. initial measurements are before HTRB and final measurements are after burn-in.

**TABLE 5(a) - CONDITIONS FOR HIGH TEMPERATURE REVERSE BIAS BURN-IN**

No.	Characteristics	Symbol	Conditions	Unit
1	Ambient Temperature	$T_{amb}$	+125 (Note 1)	$^{\circ}C$
2	Gate Source Voltage	$V_{GS}$	Variants 01 and 02: -5 (+0.2 -0) Variants 03 to 07: 3 (+0.2 -0)	V
3	Drain Source Voltage	$V_{DS}$	Variants 01 and 02: -5 (+0.2 -0) Variants 03 to 07: 3 (+0.2 -0)	V

**TABLE 5(b) - CONDITIONS FOR POWER BURN-IN AND OPERATING LIFE TESTS**

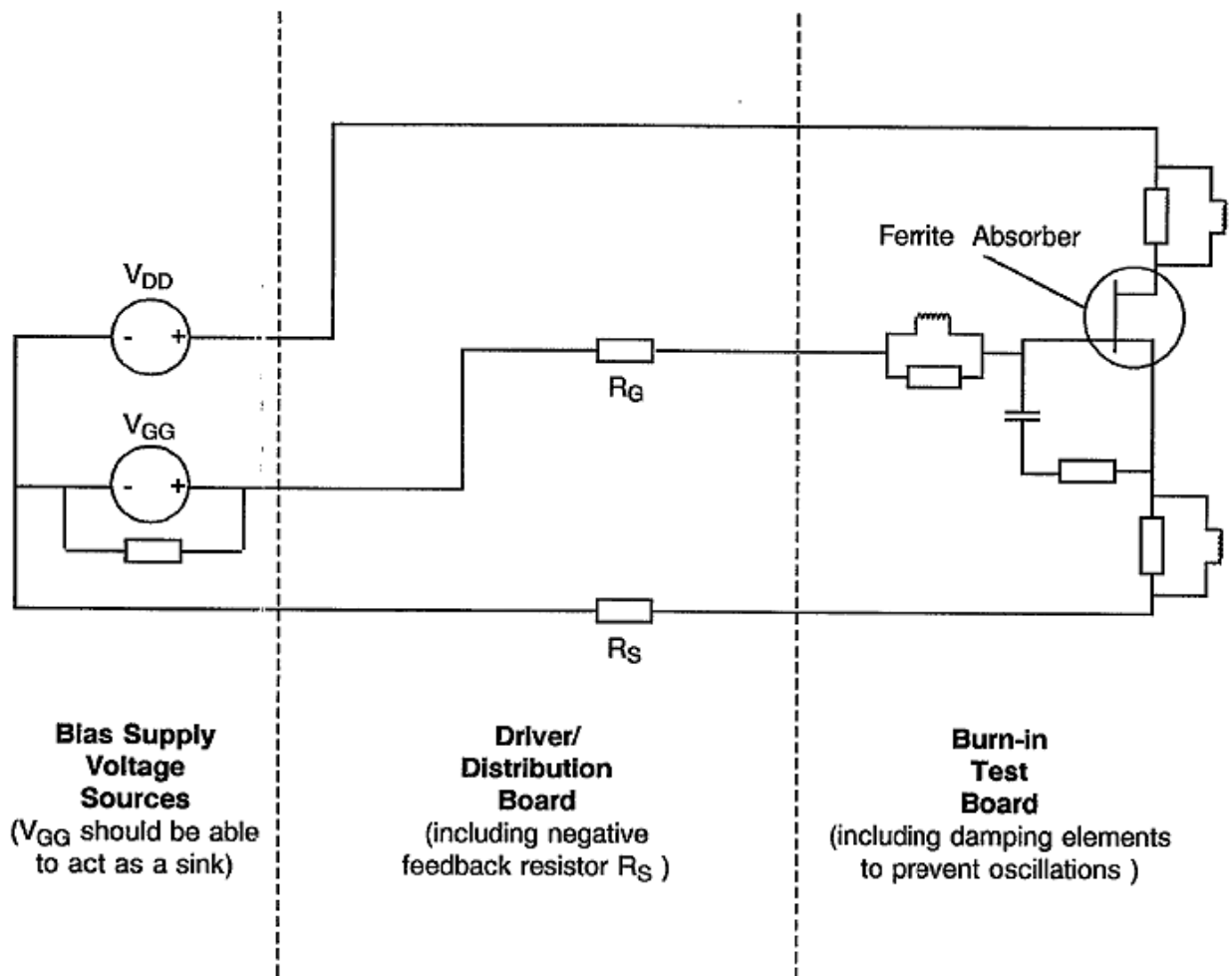
No.	Characteristics	Symbol	Conditions	Unit
1	Ambient Temperature	$T_{amb}$	+125 (Note 1)	°C
2	Channel Temperature	$T_{ch}$	+175 (+0 -5)	°C
3	Drain Source Voltage	$V_{DS}$	3 (+0 -0.2)	V
4	Drain Current	$I_D$	Variants 01 and 02: 54 Variants 03 to 07: 30 (±10%, Note 2)	mA

**NOTES:**

Because the components are mechanically clamped to the burn-in fixture, an additional thermal resistance soldering point to ambient, e.g.  $R_{TH(S-A)} = 145 \text{ }^\circ\text{C/W}$  must be considered for the calculation of  $T_{ch}$ .

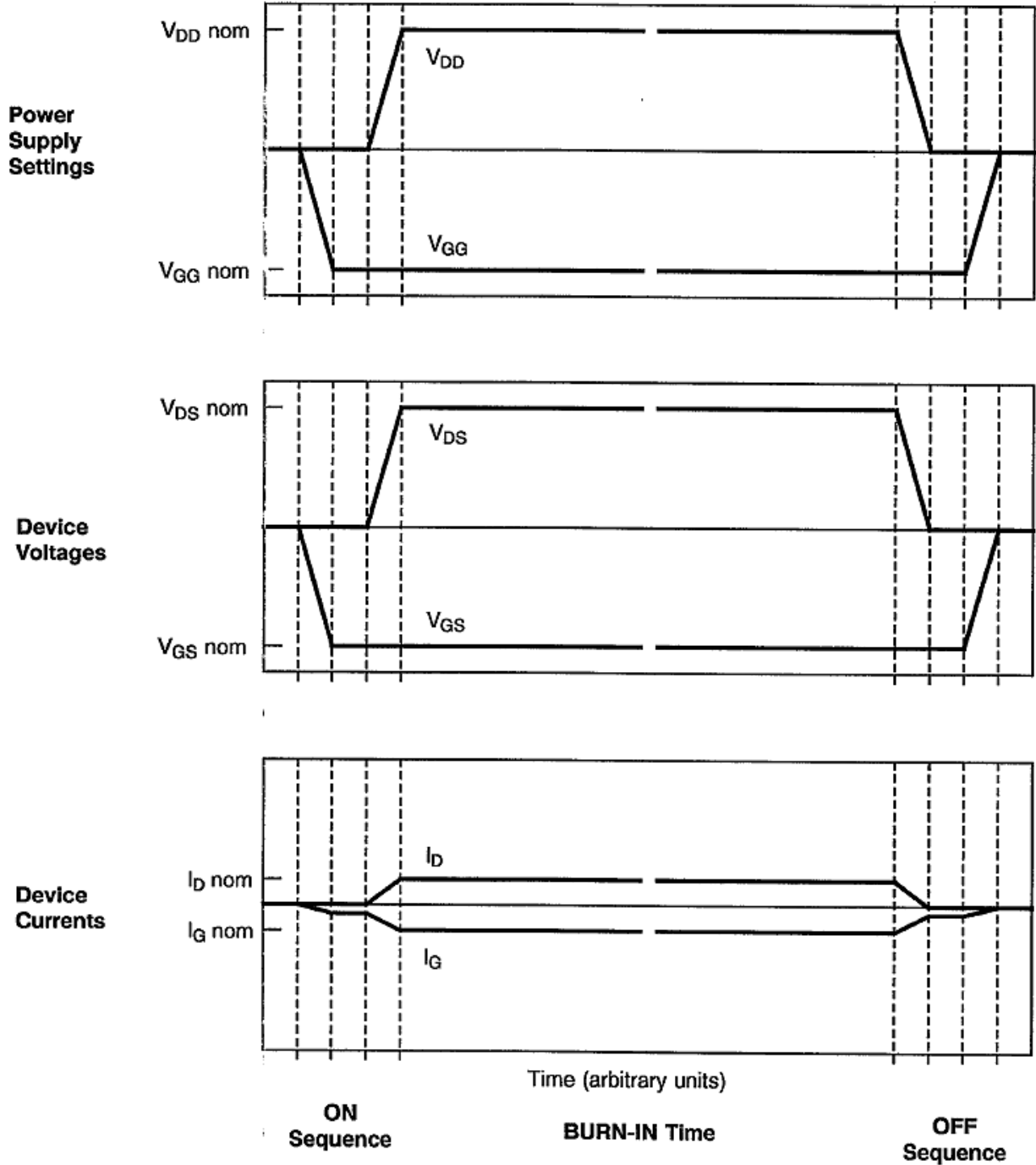
1.  $T_{amb}$  shall be adjusted to provide the required  $T_{ch}$ .
2. The limits given for  $T_{ch}$  shall not be exceeded.

**FIGURE 5 - ELECTRICAL CIRCUIT FOR BURN-IN**



**FIGURE 5 - ELECTRICAL CIRCUIT FOR BURN-IN (CONTINUED)**

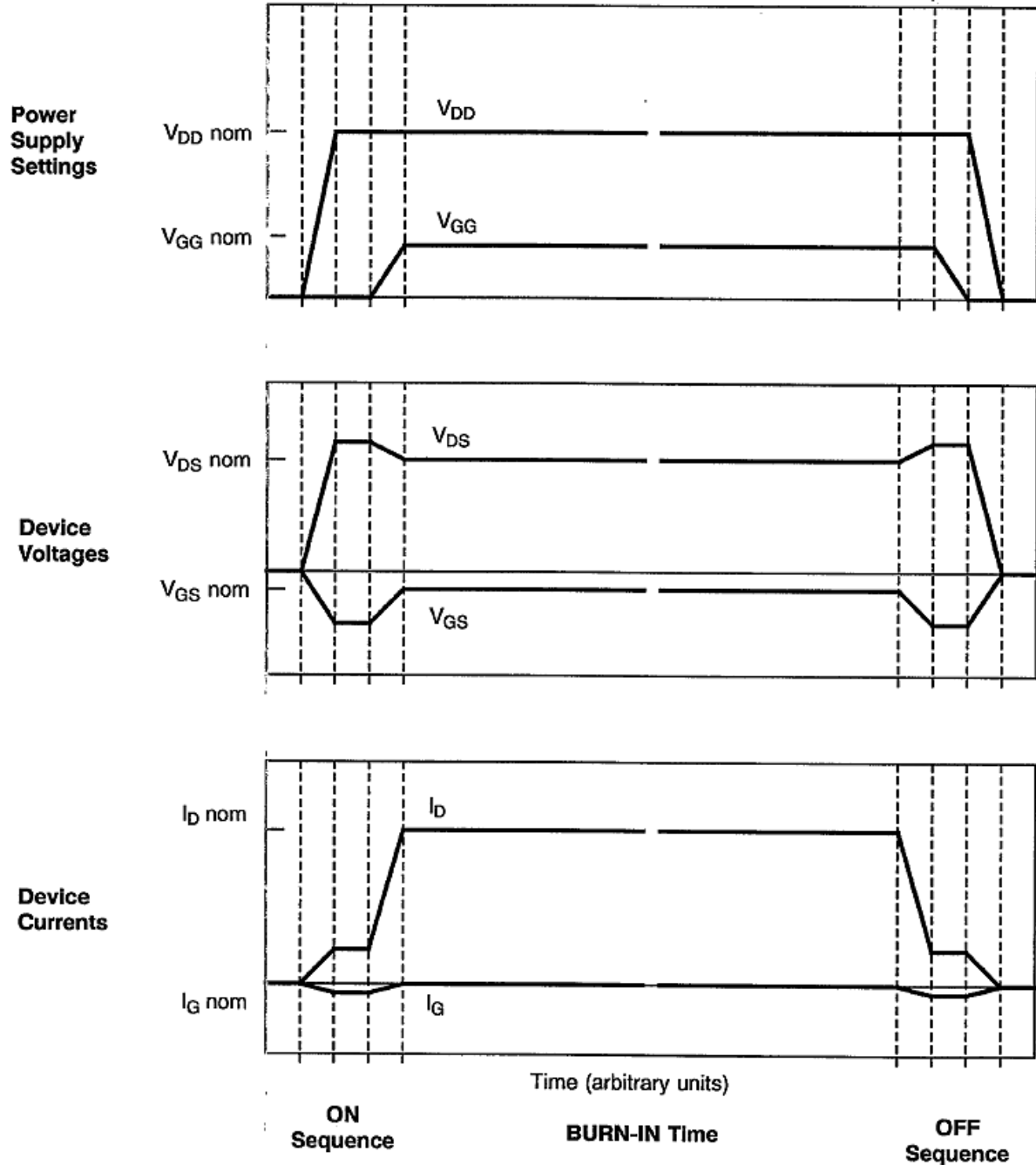
TIMING SEQUENCE FOR HTRB ON/OFF BIASING



**NOTES:** See Page 22.

**FIGURE 5 - ELECTRICAL CIRCUIT FOR BURN-IN (CONTINUED)**

**TIMING SEQUENCE FOR POWER BURN-IN ON/OFF BIASING**



**NOTES:**

1. The maximum ratings for  $V_{DS}$  and  $V_{GS}$  shall not be exceeded during the ON- or OFF-sequence. In case of jeopardy, increase of  $V_{DD}$  and  $V_{GG}$  during ON-sequence in multiple steps and decrease of  $V_{GG}$  and  $V_{DD}$  during OFF-sequence in multiple steps shall be performed.

**TABLE 6 - ELECTRICAL MEASUREMENTS AT INTERMEDIATE POINTS AND ON COMPLETION OF ENDURANCE TESTING**

No.	Characteristics	Symbol	Test Fig.	Test Conditions	Limits		Change Limits ( $\Delta$ )	Unit
					Min.	Max.		
1	Drain Leakage Current at Pinch-off 1 (high $V_{DS}$ )	$I_{Dph}$	4(a)	See Table 2 Variants 01 and 02 Variants 03 to 07	- -	600 375	N/A $\pm 150$	$\mu A$
2	Gate Leakage Current at Pinch-off 1 (high $V_{DS}$ )	$I_{Gph}$	4(a)	See Table 2 Variants 01 and 02 Variants 03 to 07	- -	-300 -250	N/A $\pm 100$	$\mu A$
3	Drain Leakage Current at Pinch-off 2 (low $V_{DS}$ )	$I_{Dpl}$	4(a)	See Table 2 Variants 01 and 02 Variants 03 to 07	- -	120 N/A	$\pm 48$ N/A	$\mu A$
4	Gate Leakage Current at Pinch-off 2 (low $V_{DS}$ )	$I_{Gpl}$	4(a)	See Table 2 Variants 01 and 02 Variants 03 to 07	- -	-60 N/A	$\pm 24$ N/A	$\mu A$
5	Drain Saturation Current	$I_{DSS}$	4(a)	See Table 2 Variants 01 and 02 Variants 03, 05, 07 Variants 04, 06	140 20 14	420 65 65	$\pm 30$ $\pm 2.5$	mA
6	Gate Source Threshold Voltage	$V_{GSth}$	4(a)	See Table 2 Variants 01 and 02 Variants 03 to 07	-0.8 -0.2	-3.3 -3.1	$\pm 0.2$ $\pm 0.1$	V
7	Transconductance	$g_m$	4(a)	See Table 2 Variants 01 and 02 Variants 03 to 07	120 33	- -	$\pm 18$ $\pm 2.5$	mS
9	Noise Figure	$NF_{min}$	4(b)	See Table 2 Variants 01, 03 to 06 Variants 02, 07	- -	(Note 1) N/A	$\pm 0.15$ N/A	dB
10	Associated Gain	$G_a$	4(b)	See Table 2 Variants 01, 03 to 06 Variants 02, 07	(Note 2) N/A	- -	$\pm 0.4$ N/A	dB
11	Output Power @ 1dB Gain Compression	$P_{-1dB}$	4(b)	See Table 2 Variants 01, 03 to 06 Variants 02, 07	N/A (Note 2)	- -	N/A -0.2 / +0.5	dB
12	Linear Power Gain	$G_{lp}$	4(b)	See Table 2 Variants 01, 03 to 06 Variants 02, 07	N/A (Note 2)	- -	N/A $\pm 0.4$	dB

**NOTES:**

1. As per Table 2, increased by 0.1dB.
2. As per Table 2, reduced by 0.2dB.

**FIGURE 6 - BIAS CONDITIONS FOR IRRADIATION TESTING**

Not applicable.

**TABLE 7 - ELECTRICAL MEASUREMENTS DURING AND ON COMPLETION OF IRRADIATION TESTING**

Not applicable.



**APPENDIX 'A'**  
**AGREED DEVIATIONS FOR INFINEON TECHNOLOGIES (D)**

ITEMS AFFECTED	DESCRIPTION OF DEVIATIONS
Para 4.2.1	Paras. 5.2.4 and 10.5: If Wafer Lot Acceptance Test Data is specified in the purchase order, such data will not be delivered but will be available for review at Infineon Technologies.
Para. 4.2.2	Para. 9.11, Dimension Check: May be performed on a 100% basis using a gauge during RF Measurements.
Para. 4.2.3	Para. 9.12, Radiographic Inspection: May be replaced by an Internal (pre-encapsulation) Visual Inspection for verifying the length, height and shape of the wire bonding.
Para. 4.2.5	Para. 8.2.3, Lot Acceptance Level 3 Testing (LA3), (e): Witnessing of LA3 testing by the Orderer is only foreseen for the Electrical Measurements at Room Temperature - DC Parameters. Notification of the Orderer shall be made 5 working days before the commencement of this testing.