



Pages 1 to 18

**CAPACITOR FILTERS, C-TYPE, ELECTROMAGNETIC
INTERFERENCE SUPPRESSION, NON-HERMETICALLY
SEALED, SURFACE MOUNT**

BASED ON TYPE SFCMS 35 TYPE C

ESCC Detail Specification No. 3008/034

Issue 1	July 2005
---------	-----------



Document Custodian: European Space Agency - see <https://escies.org>

LEGAL DISCLAIMER AND COPYRIGHT

European Space Agency, Copyright © 2005. All rights reserved.

The European Space Agency disclaims any liability or responsibility, to any person or entity, with respect to any loss or damage caused, or alleged to be caused, directly or indirectly by the use and application of this ESCC publication.

This publication, without the prior permission of the European Space Agency and provided that it is not used for a commercial purpose, may be:

- copied in whole, in any medium, without alteration or modification.
- copied in part, in any medium, provided that the ESCC document identification, comprising the ESCC symbol, document number and document issue, is removed.



DOCUMENTATION CHANGE NOTICE

(Refer to <https://escies.org> for ESCC DCR content)

DCR No.	CHANGE DESCRIPTION

TABLE OF CONTENTS

<u>1.</u>	<u>GENERAL</u>	<u>5</u>
1.1	Scope	5
1.2	Component Type Variants And Range Of Components	5
1.3	Maximum Ratings	5
1.4	Parameter Derating Information	5
1.5	Physical Dimensions	5
1.6	Functional Diagram	5
<u>2.</u>	<u>APPLICABLE DOCUMENTS</u>	<u>5</u>
<u>3.</u>	<u>TERMS, DEFINITIONS, ABBREVIATIONS, SYMBOLS AND UNITS</u>	<u>5</u>
<u>4.</u>	<u>REQUIREMENTS</u>	<u>9</u>
4.1	General	9
4.2	Deviations from Generic Specification	9
4.2.1	Deviations from Special In-process Controls	9
4.2.2	Deviations from Final Production Tests (Chart II)	9
4.2.3	Deviations from Burn-in and Electrical Measurements (Chart III)	9
4.2.4	Deviations from Qualification Tests (Chart IV)	9
4.2.5	Deviations from Lot Acceptance Tests (Chart V)	10
4.3	Mechanical Requirements	10
4.3.1	Dimension Check	10
4.3.2	Weight	10
4.3.3	Robustness of Terminations	10
4.3.4	Solderability	10
4.4	Materials and Finishes	10
4.4.1	Case	11
4.4.2	Lead Material and Finish	11
4.5	Marking	11
4.5.1	General	11
4.5.2	The ESCC Component Number	11
4.5.3	Electrical Characteristics and Ratings	11
4.5.3.1	Capacitance Value	12
4.5.3.2	Tolerance	12
4.5.3.3	Rated Voltage	12
4.5.4	Traceability Information	12
4.6	Electrical Measurements	12
4.6.1	Electrical Measurements at Room Temperature	12
4.6.2	Electrical Measurements at High and Low Temperatures	12
4.6.3	Circuits for Electrical Measurements (Figure 4)	12
4.7	Burn-in Tests	13
4.7.1	Parameter Drift Values	13
4.7.2	Conditions for Burn-in	13
4.7.3	Electrical Circuit for Burn-in (Figure 5)	13
4.8	Environmental and Endurance Tests (Charts IV and V of ESCC Generic Specification No. 3008)	15
4.8.1	Measurements and Inspections on Completion of Environmental Tests	15
4.8.2	Measurements and Inspections at Intermediate Points During Endurance Tests	15
4.8.3	Measurements and Inspections on Completion of Endurance Tests	15
4.8.4	Conditions for Operating Life	15
4.8.5	Electrical Circuit for Operating Life (Figure 5)	15

1. GENERAL

1.1 SCOPE

This specification details the ratings, physical and electrical characteristics, test and inspection data for a Capacitor Filter, C-Type, Electromagnetic Interference Suppression, Non-hermetically Sealed, Surface Mount, based on type SFCMS 35 Type C. It shall be read in conjunction with ESCC Generic Specification No. 3008, the requirements of which are supplemented herein.

1.2 COMPONENT TYPE VARIANTS AND RANGE OF COMPONENTS

Variants of the basic type components and the range of components covered by this specification are given in Table 1(a).

1.3 MAXIMUM RATINGS

The maximum ratings, which shall not be exceeded at any time during use or storage, applicable to the components specified herein, are as scheduled in Table 1(b).

1.4 PARAMETER DERATING INFORMATION

The parameter derating information applicable to the components specified herein is shown in Figure 1.

1.5 PHYSICAL DIMENSIONS

The physical dimensions of the components specified herein are shown in Figure 2.

1.6 FUNCTIONAL DIAGRAM

The functional diagram of the components specified herein is shown in Figure 3.

2. APPLICABLE DOCUMENTS

The following documents form part of this specification and shall be read in conjunction with it:

- (a) ESCC Generic Specification No. 3008 for Capacitors and Capacitor Filters, Feedthrough.
- (b) MIL-STD-202, Test Methods for Electronic and Electrical Component Parts.

3. TERMS, DEFINITIONS, ABBREVIATIONS, SYMBOLS AND UNITS

For the purpose of this specification, the terms, definitions, abbreviations, symbols and units specified in ESCC Basic specification No. 21300 shall apply.

Table 1(a) - TYPE VARIANTS AND RANGE OF COMPONENTS

Variant	Rated Voltage U_R (V)	Capacitance Range C (pF) (±10%, 20%) (E12 Series - see Table below)	Voltage Proof VP (V)	Weight max (g)
	-55°C ≤ T_{amb} ≤ +85°C Note 1			
01, 04	50	470 to 22000	125	2 (Variants 01 to 03) 1 (Variants 04 to 06)
02, 05	100	470 to 18000	250	
03, 06	200	470 to 8200	500	

INSERTION LOSS VALUES ACCORDING TO THE CAPACITANCE VALUE

Capacitance C (pF)	Insertion Loss I _L (dB)						
	10MHz	50MHz	100MHz	500MHz	1GHz	5GHz	10GHz
470	-	8	14	28	34	48	54
560	-	9	15	29	35	49	55
680	-	11	17	31	37	51	57
820	-	13	19	33	39	53	59
1000	-	15	21	35	41	55	61
1200	-	16	22	36	42	56	62
1500	-	18	24	38	44	58	64
1800	-	19	25	39	46	59	66
2200	-	21	27	41	48	61	68
2700	9	23	29	43	50	63	70
3300	11	25	31	45	52	60	70
3900	12	26	32	46	53	66	70
4700	14	28	34	48	54	68	70
5600	15	29	35	49	55	69	70
6800	17	31	37	51	57	70	70
8200	19	33	39	53	59	70	70
10000	21	35	41	43	61	70	70
12000	23	37	43	45	63	70	70
15000	25	39	45	47	65	70	70
18000	26	40	46	52	66	70	70
22000	28	42	48	54	68	70	70

NOTES:

1. U_R is derated +85°C < T_{amb} ≤ +125°C. See Figure 1.

Table 1(b) - MAXIMUM RATINGS

No.	Characteristics	Symbol	Maximum Ratings	Unit	Remarks
1	Rated DC Voltage	U_R	See Table 1(a)	V	Note 1
2	Voltage Drop	V_{dr}	50	mV	
3	DC Resistance	R_S	5	m Ω	
4	DC and Low Frequency Current	I_R	10	A	
5	Operating Temperature Range	T_{op}	-55 to +125	$^{\circ}\text{C}$	T_{amb}
6	Storage Temperature Range	T_{stg}	-55 to +125	$^{\circ}\text{C}$	
7	Soldering Temperature	T_{sol}	+260	$^{\circ}\text{C}$	Note 2

NOTES:

1. The addition of DC applied voltage and ripple voltage shall never exceed the rated DC voltage.
2. Duration 6 seconds maximum and the same termination, or the case, shall not be resoldered until 3 minutes have elapsed.

FIGURE 1- PARAMETER DERATING INFORMATION

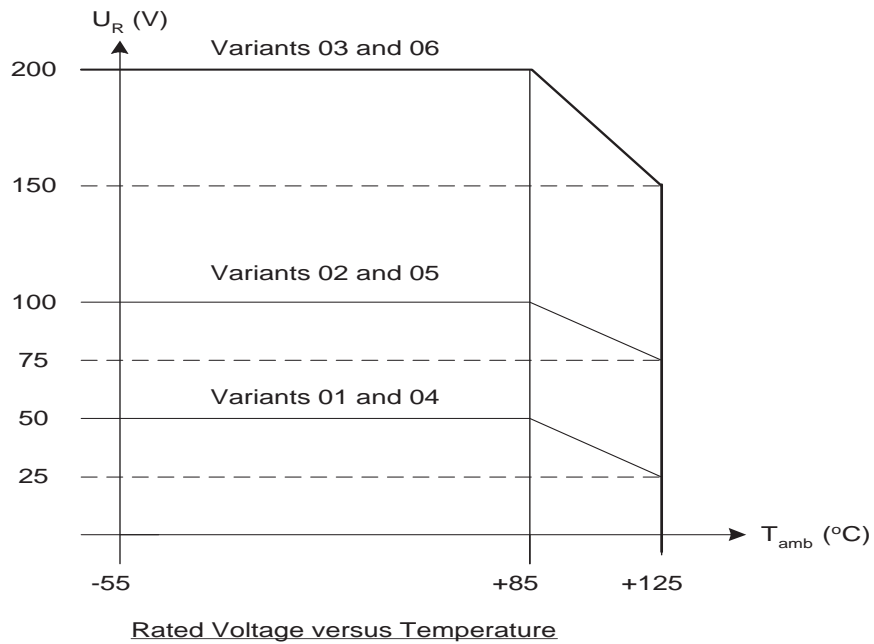
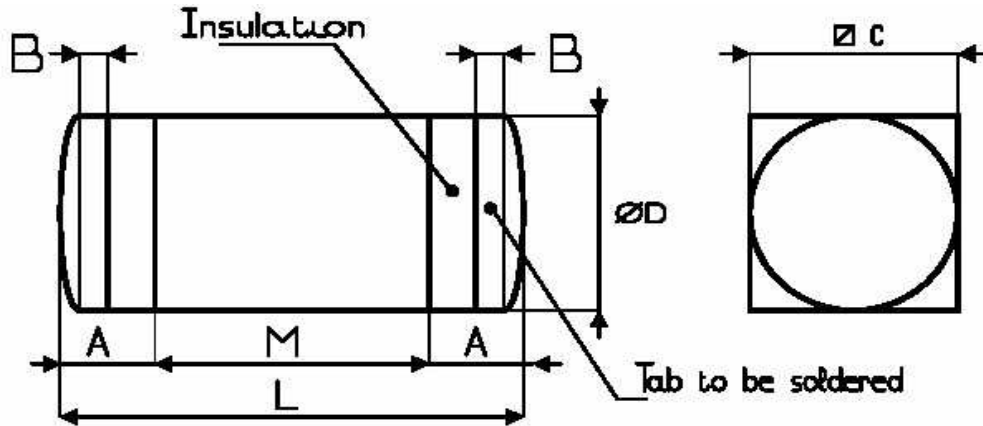

FIGURE 2 - PHYSICAL DIMENSIONS



Symbol	Dimensions (mm)				Remarks
	Variants 01, 02 and 03		Variants 04, 05 and 06		
	Min	Max	Min	Max	
A	1.9	2.6	1.9	2.6	
B	0.7	0.9	0.7	0.9	
C	3.5	3.6	3.5	3.6	Note 1
ØD	3.5	3.6	3.5	3.6	Note 2
L	11.3	12.7	6.5	8.5	
M	7.4	7.6	2.7	3.3	

NOTES:

1. This dimension applies to the square-section case (Ground), over dimension M. One of the four faces shall bear marking in accordance with Para. 4.5.
2. This dimension (diameter) applies to both the tab termination and the insulation.

FIGURE 3 - FUNCTIONAL DIAGRAM

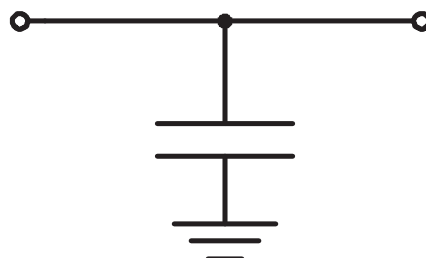

4. REQUIREMENTS

4.1 GENERAL

The complete requirements for procurement of the components specified herein are stated in this specification and ESCC Generic Specification No. 3008 for Capacitors and Capacitor Filters, Feedthrough. Deviations from the Generic Specification, applicable to this specification only, are detailed in Para. 4.2.

Deviations from the applicable Generic Specification and this Detail Specification, formally agreed with specific Manufacturers on the basis that the alternative requirements are equivalent to the ESCC requirements and do not affect the components' reliability, are listed in the appendices attached to this specification.

4.2 DEVIATIONS FROM GENERIC SPECIFICATION

4.2.1 Deviations from Special In-process Controls

None.

4.2.2 Deviations from Final Production Tests (Chart II)

- (a) Para. 9.4.1.5, Voltage Drop: Shall be performed as a DC resistance measurement in accordance with MIL-STD-202, Method 303.
- (b) Para. 9.2, Rapid Change of Temperature: The Components may not be mounted.
- (c) Para. 9.3, Vibration: Not applicable.

4.2.3 Deviations from Burn-in and Electrical Measurements (Chart III)

- (a) Para. 9.4.1.5, Voltage Drop: Shall be performed as a DC resistance measurement in accordance with MIL-STD-202, Method 303.
- (b) Paras. 9.4.3, Electrical Measurements at High and Low Temperature and 9.4.4, Electrical Measurements at Room Temperature: Insertion Loss is considered as destructive and the parts so tested cannot be delivered as flight models. Therefore, these tests shall be performed at the end of Chart III and parts rejected during External Visual Inspection, or Radiographic Inspection, but electrically acceptable after Burn-in, may be used.

4.2.4 Deviations from Qualification Tests (Chart IV)

- (a) Para. 9.4.1.5, Voltage Drop: Shall be performed as a DC resistance measurement in accordance with MIL-STD-202, Method 303.
- (b) Para. 9.12, Accelerated Damp Heat: Voltage Proof and Insertion Loss shall not be performed.
- (c) Para. 9.14, Robustness of Terminations: Only test Ua is applicable.
- (d) Para. 9.15, Immersion: Not applicable.
- (e) Para. 9.17, Resistance to Soldering Heat: May be performed prior to Para. 9.11, Vibration. Capacitance is performed in lieu of Insertion Loss at Final Measurements.
- (f) Para. 9.18, Solderability: May be performed prior to Para. 9.10, Shock.
- (g) Para. 9.19, Operating Life (Intermediate and End Data Points): Insertion Loss shall not be performed.

4.2.5 Deviations from Lot Acceptance Tests (Chart V)

- (a) Para. 9.4.1.5, Voltage Drop: Shall be performed as a DC resistance measurement in accordance with MIL-STD-202, Method 303.
- (b) Para. 9.14, Robustness of Terminations: Only test Ua is applicable.
- (c) Para. 9.15, Immersion: Not applicable.
- (d) Para. 9.18, Solderability: as described in Para. 4.2.4(g) above.
- (e) Para. 9.19, Operating Life (Intermediate and End Data Points): Insertion Loss shall not be performed.

4.3 MECHANICAL REQUIREMENTS

4.3.1 Dimension Check

The dimensions of the components specified herein shall be verified in accordance with the requirements set out in Para. 9.5 of ESCC Generic Specification No. 3008 and they shall conform to those shown in Figure 2 of this specification.

4.3.2 Weight

The maximum weight of the components specified herein shall be as given in Table 1(a).

4.3.3 Robustness of Terminations

The requirements for the robustness of terminations tests are specified in Para. 9.14 of the Generic Specification and below.

Add to Para. 9.14.1 of the Generic Specification

For surface mount components, capacitors shall be mounted on a suitable substrate. After mounting, examination shall be made for good tinning as evidenced by flowing of the solder with wetting of the terminations.

Add to Para. 9.14.2 (for method Ua) of the Generic Specification

For surface mount components, a force of 10N shall be applied on the terminations normal to the length of the case and in a plane parallel to the substrate, duration = 10s.

Add to Para. 9.14.3 of the Generic Specification

For surface mount components there shall be no evidence of damage or loosening of the components from the substrate.

4.3.4 Solderability

The requirements for solderability testing are specified in Para. 9.18 of the Generic Specification and below.

The test shall be carried out in accordance with IEC 68 - 2 - 20 standard with the following conditions:

- Test Ta, Method 1
- Temperature: $+235\pm 3^{\circ}\text{C}$
- Immersion time: 3 ± 0.3 seconds

The terminations shall be immersed to the distance B defined in Figure 2.

4.4 MATERIALS AND FINISHES

The materials and finishes shall be as specified herein. Where a definite material is not specified, a

material which will enable the components specified herein to meet the performance requirements of this specification shall be used. Acceptance or approval of any constituent material does not guarantee acceptance of the finished product.

4.4.1 Case

The case shall be silver plated brass.

4.4.2 Lead Material and Finish

The tab material shall be brass with tin-lead layer (lead>95%) with Nickel and Silver underplating.

4.5 MARKING

4.5.1 General

The marking of components delivered to this specification shall be in accordance with the requirements of ESCC Basic Specification No. 21700 and the following paragraphs. When the component is too small to accommodate all of the marking specified, as much as space permits shall be marked and the marking information, in full, shall accompany the component in its primary package.

The information to be marked and the order of precedence, shall be as follows:

- (a) The ESCC Component Number.
- (b) Electrical Characteristics and Ratings
- (c) Traceability Information

4.5.2 The ESCC Component Number

The ESCC Component Number shall be constituted and marked as follows:

Example: 300803401B

- Detail Specification Reference: 3008034
- Component Type Variant Number: 01 (as required)
- Testing Level (B or C, as applicable)

4.5.3 Electrical Characteristics and Ratings

The electrical characteristics and ratings to be marked in the following order of precedence are:

- (a) Capacitance Value
- (b) Tolerance
- (c) Rated Voltage

The information shall be constituted and marked as follows:

Example: 682KC

- Capacitance Value (6800pF): 682
- Tolerance ($\pm 10\%$): K
- Rated Voltage (50V): C

4.5.3.1 Capacitance Value

The capacitance value shall be expressed by means of the following codes. The unit quantity for marking shall be picofarads (pF).

Capacitance Value (pF)	Code
XX10 ¹	XX1
XX10 ²	XX2
XX10 ³	XX3

4.5.3.2 Tolerance

The tolerance on capacitance value shall be indicated by the code letters specified hereafter.

Tolerance (±%)	Code Letter
10	K
20	M

4.5.3.3 Rated Voltage

The rated voltage shall be indicated by the code letters specified hereafter.

Rated Voltage (V)	Code Letter
50	C
100	E
200	G

4.5.4 Traceability Information

Each component shall be marked in respect of traceability information in accordance with the requirements of ESCC Basic Specification No. 21700.

4.6 ELECTRICAL MEASUREMENTS

4.6.1 Electrical Measurements at Room Temperature

The parameters to be measured at room temperature are scheduled in Table 2. Unless otherwise specified, measurements shall be performed at $T_{amb}=+22\pm 3^{\circ}\text{C}$.

4.6.2 Electrical Measurements at High and Low Temperatures

The parameters to be measured at high and low temperatures are scheduled in Table 3. Measurements shall be performed at $T_{amb}+125(+0-5)^{\circ}\text{C}$ and $-55(+5-0)^{\circ}\text{C}$ respectively.

4.6.3 Circuits for Electrical Measurements (Figure 4)

Not applicable.

4.7 BURN-IN TESTS

4.7.1 Parameter Drift Values

The parameter drift values applicable to Burn-in are as specified in Table 4 of this specification. Unless otherwise stated, measurements shall be performed at $T_{amb}=+22\pm 3^{\circ}\text{C}$. The parameter drift values (Δ) applicable to the parameters scheduled shall not be exceeded. In addition to these drift value requirements for a given parameter, the appropriate limit values specified in Table 2 shall not be exceeded.

4.7.2 Conditions for Burn-in

The requirements for Burn-in are specified in Section 7 of ESCC Generic Specification No. 3008. The conditions for Burn-in shall be as specified in Table 5(a) of this specification.

4.7.3 Electrical Circuit for Burn-in (Figure 5)

Not applicable.

Table 2 - ELECTRICAL MEASUREMENTS AT ROOM TEMPERATURE - DC PARAMETERS

No.	Characteristics	Symbol	ESCC 3008 Test Method	Test Conditions	Limits		Unit
					Min	Max	
1	DC Resistance	R_S	MIL-STD-202 Method 303	-	-	5	$m\Omega$
2	Voltage Proof	VP	Para. 9.4.1.2	$V+2.5U_R$ Note 2	Note 1	-	V
3	Insulation Resistance	R_i	Para. 9.4.1.3	Para. 9.4.1.3	10^4	-	$M\Omega$

Table 2 - ELECTRICAL MEASUREMENTS AT ROOM TEMPERATURE - AC PARAMETERS

No.	Characteristics	Symbol	ESCC 3008 Test Method	Test Conditions	Limits		Unit
					Min	Max	
4	Insertion Loss, Note 6	I_{L1}	Para. 9.4.1.4	$f=10\text{MHz}$, Note 4	Note 1	-	dB
5	Insertion Loss	I_{L2}	Para. 9.4.1.4	$f=50\text{MHz}$, Note 3	Note 1	-	dB
6	Insertion Loss, Note 6	I_{L3}	Para. 9.4.1.4	$f=100\text{MHz}$, Note 4	Note 1	-	dB
7	Insertion Loss	I_{L4}	Para. 9.4.1.4	$f=500\text{MHz}$, Note 3	Note 1	-	dB
8	Insertion Loss, Note 6	I_{L5}	Para. 9.4.1.4	$f=1\text{GHz}$, Note 4	Note 1	-	dB
9	Insertion Loss	I_{L6}	Para. 9.4.1.4	$f=5\text{GHz}$, Note 3	Note 1	-	dB
10	Insertion Loss	I_{L7}	Para. 9.4.1.4	$f=10\text{GHz}$, Note 3	Note 1	-	dB
11	Capacitance	C	Para. 9.4.1.1	$f=1\text{kHz}\pm 100\text{Hz}$ $V=0.1$ to 1.2Vrms	Note 1	-	pF

Table 3 - ELECTRICAL MEASUREMENTS AT HIGH AND LOW TEMPERATURES

No.	Characteristics	Symbol	ESCC 3008 Test Method	Test Conditions	Limits		Unit
					Min	Max	
3	Insulation Resistance Note 5	R_i	Para. 9.4.1.3	Para. 9.4.1.3 $T_{amb}=+125(+0 -5)^{\circ}\text{C}$	10^3	-	$M\Omega$
4	Insertion Loss Note 6	I_{L1}	Para. 9.4.1.4	$f=10\text{MHz}$, No current	Note 1	-	dB

No.	Characteristics	Symbol	ESCC 3008 Test Method	Test Conditions	Limits		Unit
					Min	Max	
6	Insertion Loss Note 6	I_{L3}	Para. 9.4.1.4	$f=100\text{MHz}$, No current	Note 1	-	dB
8	Insertion Loss Note 6	I_{L5}	Para. 9.4.1.4	$f=1\text{GHz}$, No current	Note 1	-	dB

NOTES TO TABLES 2 and 3:

1. See Table 1(a).
2. See Table 1(a) for value U_R .
3. Measurements at this frequency to be made only during Chart IV testing.
4. Measurements at rated current to be made only during Chart IV testing. Measurements without load current to be made during Charts III and V. NB: Not performed during Chart II testing.
5. This measurement must be carried out at the end of the Burn-in in accordance with Para. 9.23 of ESCC Generic Specification No. 3008 and shall not be carried out again.
6. Measurements at Room, High and Low Temperatures to be made on a sample of 5 parts per lot. If one or more failures occur then another 5 samples shall be tested. If one or more of the additional 5 samples fails then the lot shall be rejected. The samples shall be mounted on a suitable substrate prior to measurements. See also Para. 4.2.3.

FIGURE 4 - CIRCUITS FOR ELECTRICAL MEASUREMENTS

Not applicable.

Table 4 - PARAMETER DRIFT VALUES

No.	Characteristics	Symbol	Spec. and/or Test Method	Test Conditions	Change Limits (Δ)	Unit
11	Capacitance Change	$\Delta C/C$	As per Table 2	As per Table 2	± 10	%

Table 5(a) - CONDITIONS FOR BURN-IN

No.	Characteristics	Symbol	Condition	Unit
1	Ambient Temperature	T_{amb}	$+125(+0 -3)$	$^{\circ}\text{C}$
2	Test Voltage	V_T	$2xU_R$ at $+125^{\circ}\text{C}$ Note 1	V

NOTES:

1. Applied between one terminal and the case. See Table 1(a) for value of U_R .

Table 5(b) - CONDITIONS FOR OPERATING LIFE

No.	Characteristics	Symbol	Condition	Unit
1	Ambient Temperature	T_{amb}	$+125(+0 -3)$	$^{\circ}\text{C}$
2	Test Voltage	V_T	$2xU_R$ at $+125^{\circ}\text{C}$ Note 1	V
3	Rated Current	I_R	10	A

NOTES:

1. Applied between one terminal and the case. See Table 1(a) for value of U_R .

FIGURE 5 - ELECTRICAL CIRCUIT FOR BURN-IN AND OPERATING LIFE

Not applicable.

4.8 ENVIRONMENTAL AND ENDURANCE TESTS (CHARTS IV AND V OF ESCC GENERIC SPECIFICATION NO. 3008)

4.8.1 Measurements and Inspections on Completion of Environmental Tests

The parameters to be measured and inspections to be performed on completion of environmental tests are scheduled in Table 6. Unless otherwise stated, the measurements shall be performed at $T_{amb}=+22\pm 3^{\circ}C$.

4.8.2 Measurements and Inspections at Intermediate Points During Endurance Tests

The parameters to be measured and inspections to be performed at intermediate points during endurance tests are scheduled in Table 6. Unless otherwise stated, the measurements shall be performed at $T_{amb}=+22\pm 3^{\circ}C$.

4.8.3 Measurements and Inspections on Completion of Endurance Tests

The parameters to be measured and inspections to be performed on completion of endurance tests are scheduled in Table 6. Unless otherwise stated, the measurements shall be performed at $T_{amb}=+22\pm 3^{\circ}C$.

4.8.4 Conditions for Operating Life

The requirements for operating life test are specified in Section 9 of ESCC Generic Specification No. 3008. The conditions for operating life testing shall be as specified in Table 5(b) of this specification.

4.8.5 Electrical Circuit for Operating Life (Figure 5)

Not applicable.

Table 6 - MEASUREMENTS AND INSPECTIONS ON COMPLETION OF ENVIRONMENTAL TESTS AND AT INTERMEDIATE POINTS AND ON COMPLETION OF ENDURANCE TESTING

No.	ESCC Generic Spec. No. 3008		Measurements and Inspections		Symbol	Limits		Unit
	Environmental and Endurance Tests (1)	Test Methods and Conditions	Identification	Conditions		Min	Max	
01	Seal Test (Hermetically Sealed)	Para. 9.6	Not applicable					
02	External Visual Inspection	Para. 9.7	<u>Final Measurements</u> Visual Inspection	ESCC No. 20500	-	-	-	-
03	Temperature Rise	Para. 9.9	Temperature Rise	Rated Current (3)	-	-	25	$^{\circ}C$
04	Shock	Para. 9.10	<u>Measurements during Tests</u>	100% U_R (2) applied No Open or Short Circuits $>100\mu s$				
			<u>Final Measurements</u> Visual Examination	No Mechanical Damage	-	-	-	-
			Insertion Loss	Table 2 Items 4 to 10	I_L	Table 2	-	dB
05	Vibration	Para. 9.11	<u>Measurements during Tests</u> During last cycle	Current (7) and 100% U_R (2) applied No Open or Short Circuits $>100\mu s$				
			<u>Final Measurements</u> Visual Examination	No Mechanical Damage	-	-	-	-
			Insertion Loss	Table 2 Items 4 to 10	I_L	Table 2	-	dB

No.	ESCC Generic Spec. No. 3008		Measurements and Inspections		Symbol	Limits		Unit
	Environmental and Endurance Tests (1)	Test Methods and Conditions	Identification	Conditions		Min	Max	
06	Accelerated Damp Heat	Para. 9.12 and Para. 4.2.4 of this spec.	<u>Final Measurements</u>	After recovery of 4 to 24 hours				
			Visual Examination	No corrosion or obliteration of marking	-	-	-	-
			Insulation Resistance	Table 2 Item 3	R _i	(5)	-	MΩ
07	Low Air Pressure	Para. 9.13	<u>Measurements during Tests</u>	during last 5 minutes				
			Voltage Proof	Table 2 Item 2	VP	125% U _R (2)	-	V
			Visual Examination	No breakdown, flashover, deformation or seepage	-	-	-	-
			<u>Final Measurements</u>					
			Visual Examination	No breakdown, flashover, deformation or seepage	-	-	-	-
08	Robustness of Terminations	Para. 9.14 and Paras. 4.2.4, 4.2.5 and 4.3.3 of this spec.	<u>Final Measurements</u>					
			Visual Examination	No damage	-	-	-	-
			DC Resistance	Table 2 Item 1	R _S	-	Table 2	mΩ
09	Immersion	Para. 9.15 and Paras. 4.2.4 and 4.2.5 of this spec.	Not applicable					
10	Overload	Para. 9.16	<u>Final Measurements</u>	140% of Rated Current (3) for 15 mins min.				
			Insulation Resistance	Table 2 Item 3	R _i	Table 2	-	MΩ
			DC Resistance	Table 2 Item 1	R _S	-	Table 2	mΩ
			Visual Examination	No damage	-	-	-	-
11	Resistance to Soldering Heat	Para. 9.17 and Para. 4.2.4(b) of this spec.	<u>Final Measurements</u>	After recovery of 1 to 2 hrs				
			Visual Examination	No damage	-	-	-	-
			Insulation Resistance	Table 2 Item 3	R _i	Table 2	-	MΩ
			Capacitance	Table 2 Item 11	C	Table 2	-	pF
12	Solderability	Para. 9.18 and Para. 4.3.4 of this spec	<u>Final Measurements</u>					

No.	ESCC Generic Spec. No. 3008		Measurements and Inspections		Symbol	Limits		Unit
	Environmental and Endurance Tests (1)	Test Methods and Conditions	Identification	Conditions		Min	Max	
			Visual Examination	IEC No. 68-2-20 Para. 4.6.4, 4.7.4 or 4.9.3	-	-	-	-
13	Operating Life	Para. 9.19 and Paras. 4.2.4 and 4.2.5 of this spec.	During tests <u>Initial Measurements</u> Voltage Drop Voltage Proof Insulation Resistance Capacitance <u>Intermediate Measurements</u> Insulation Resistance Voltage Drop Voltage Proof Insulation Resistance Capacitance Capacitance Change <u>Final Measurements</u> Insulation Resistance Voltage Drop Voltage Proof Insulation Resistance Capacitance Capacitance Change	Open or short Circuit ESCC 3008, Para. 9.4.1.5 Table 2, Item 2 Table 2, Item 3 Table 2, Item 11 Table 3, Item 3 After 24 hours recovery ESCC 3008, Para. 9.4.1.5 Table 2, Item 2 Table 2, Item 3 Table 2, Item 11 Table 2, Item 11 Table 3, Item 3 After 24 hours recovery ESCC 3008, Para. 9.4.1.5 Table 2, Item 2 Table 2, Item 3 Table 2, Item 11 Table 2, Item 11	- V_{dr} VP Ri C Ri V_{dr} VP Ri C $\Delta C/C$ Ri V_{dr} VP Ri C $\Delta C/C$	- - 90% U_R (2) Table 2 Table 2 Table 3 - - 90% U_R (2) (4) Table 2 - Table 4 Table 3 - - 90% U_R (2) (4) Table 2 - Table 4	- V V M Ω pF M Ω V V M Ω pF % M Ω V V M Ω pF %	
14	Corrosion	Para. 9.20	<u>Final Measurements</u> Visual Examination	No corrosion, damage or obliteration of marking	-	-	-	-
15	Permanence of Marking	Para. 9.21	<u>Final Measurements</u> Visual Examination	No corrosion or obliteration of marking	-	-	-	-

No.	ESCC Generic Spec. No. 3008		Measurements and Inspections		Symbol	Limits		Unit
	Environmental and Endurance Tests (1)	Test Methods and Conditions	Identification	Conditions		Min	Max	
16	Damp Heat (Non-hermetically Sealed)	Para. 9.24	<u>Final Measurements</u>	After 4 hours recovery				
			Visual Examination	No cracking or encapsulant separation	-	-	-	-
			Insulation Resistance	Under 1.5V	Ri	(5)	-	MΩ

NOTES:

1. The tests in this Table refer to either Chart IV or V and shall be used as applicable.
2. For U_R , see Table 1(a).
3. For I_R , see Table 1(a).
4. Greater than 50% of the value given in Table 2.
5. Greater than 10% of the value given in Table 2.
6. For Voltage Drop limit, see Table 1(a).
7. The minimum current required for monitoring purposes shall be applied (see Para. 9.11.3 of ESCC Generic Specification No. 3008).