



Page 1 of 27

**CONNECTORS, ELECTRICAL, RECTANGULAR,
REMOVABLE CRIMP CONTACTS**

BASED ON TYPE D*MA

ESCC Detail Specification No. 3401/002

Issue 8	January 2014
---------	--------------



Document Custodian: European Space Agency – see <https://escies.org>

LEGAL DISCLAIMER AND COPYRIGHT

European Space Agency, Copyright © 2014, All rights reserved.

The European Space Agency disclaims any liability or responsibility, to any person or entity, with respect to any loss or damage caused, or alleged to be caused, directly or indirectly by the use and application of this ESCC publication.

This publication, without the prior permission of the European Space Agency and provided that it is not used for a commercial purpose, may be:

- copied in whole, in any medium, without alteration or modification.
- copied in part, in any medium, provided that the ESCC document identification, comprising the ESCC symbol, document number and document issue, is removed.

DOCUMENTATION CHANGE NOTICE

(Refer to <https://escies.org> for ESCC DCR content)

DCR No.	CHANGE DESCRIPTION
812	Specification upissued to incorporate editorial and technical changes per DCR.

TABLE OF CONTENTS

1	GENERAL	6
1.1	SCOPE	6
1.2	COMPONENT TYPE VARIANTS	6
1.3	MAXIMUM RATINGS	6
1.4	PARAMETER DERATING INFORMATION	6
1.5	PHYSICAL DIMENSIONS	6
2	APPLICABLE DOCUMENTS	7
3	TERMS, DEFINITIONS, ABBREVIATIONS, SYMBOLS AND UNITS	7
4	REQUIREMENTS	17
4.1	GENERAL	17
4.2	DEVIATIONS FROM GENERIC SPECIFICATION	17
4.2.1	Deviations from Special In-process Controls	17
4.2.2	Deviations from Final Production Tests (Chart II)	17
4.2.3	Deviations from Burn-in and Electrical Measurements (Chart III)	17
4.2.4	Deviations from Qualification Tests (Chart IV)	17
4.2.5	Deviations from Lot Acceptance Tests (Chart V)	17
4.3	MECHANICAL REQUIREMENTS	17
4.3.1	Dimension Check	17
4.3.2	Weight	17
4.3.3	Contact Capability	17
4.3.4	Contact Retention (In Insert)	17
4.3.5	Mating and Unmating Forces	18
4.3.6	Insert Retention (In Shell)	18
4.3.7	Jackscrew Retention	18
4.3.8	Contact Insertion and Withdrawal Forces	18
4.3.9	Engagement and Separation Forces	18
4.3.10	Oversize Pin Exclusion	18
4.3.11	Probe Damage	18
4.3.12	Solderability	18
4.4	MATERIALS AND FINISHES	18
4.4.1	Shells	18
4.4.2	Inserts	18
4.4.3	Contacts	18
4.4.4	Contact Retaining Clip	18
4.4.5	Guiding and Locking Devices	18

4.4.6	Magnetism Level	19
4.5	MARKING	19
4.5.1	General	19
4.5.2	Contact Identification	19
4.5.3	The ESCC Component Number	19
4.5.4	Characteristics	20
4.5.5	Traceability Information	21
4.6	ELECTRICAL MEASUREMENTS	22
4.6.1	Electrical Measurements at Room Temperature	22
4.6.2	Electrical Measurements at High and Low Temperatures (Table 3)	22
4.6.3	Circuits for Electrical Measurements (Figure 4)	22
4.7	BURN-IN AND ELECTRICAL MEASUREMENTS (TABLES 4 AND 5)	22
4.8	ENVIRONMENTAL AND ENDURANCE TESTS	22
4.8.1	Measurements and Inspections on Completion of Environmental Tests	22
4.8.2	Measurements and Inspections at Intermediate Points during Endurance Tests	22
4.8.3	Measurements and Inspections on Completion of Endurance Tests	22
4.8.4	Conditions for Operating Life Test (Part of Endurance Testing)	22
4.8.5	Electrical Circuits for Operating Life Test	22
4.8.6	Conditions for High Temperature Storage Test (Part of Endurance Testing)	22
APPENDIX A		27

1 GENERAL

1.1 SCOPE

This specification details the ratings, physical and electrical characteristics, test and inspection data for Connectors, Electrical, Rectangular with Removable Crimp Contacts, Standard (Gauge 20) and High Density (Gauge 22) Contact Arrangements, based on Type D*MA.

It shall be read in conjunction with:

- ESCC Generic Specification No. 3401, Connectors, Electrical, Non-Filtered, Circular and Rectangular.
- ESCC Detail Specification No. 3401/005, Contacts, Electrical, Crimp, for 3401/002 Connectors.
- ESCC Detail Specification No. 3401/022, Accessories for Rectangular Connectors 3401/001, 3401/002 and Connector Savers 3401/020, 3401/080.
- ESCC Detail Specification No. 3401/072, Lightweight Accessories for Rectangular Connectors 3401/001 and 3401/002.
- ESCC Detail Specification No. 3401/085, Fast-Locking Screw Lock Assemblies for Rectangular Connectors 3401/001, 3401/002 and Connector Savers 3401/020, 3401/080.

the requirements of which are supplemented herein.

1.2 COMPONENT TYPE VARIANTS

The different sizes of connectors specified herein, which are also covered by this specification, together with their mechanical characteristics, are given in Table 1(a).

1.3 MAXIMUM RATINGS

The maximum ratings, which shall not be exceeded at any time during use or storage, applicable to the connectors specified herein, are scheduled in Table 1(b).

1.4 PARAMETER DERATING INFORMATION

The applicable derating information for the connectors specified herein is shown in Figure 1.

1.5 PHYSICAL DIMENSIONS

The physical dimensions of the connectors specified herein are shown in Figure 2.

2 APPLICABLE DOCUMENTS

The following documents form part of this specification and shall be read in conjunction with it:

- (a) ESCC Generic Specification No. 3401 for Connectors, Electrical, Non-Filtered, Circular and Rectangular.
- (b) ESCC Detail Specification No. 3401/005, Contacts, Electrical, Crimp, for 3401/002 Connectors.
- (c) ESCC Detail Specification No. 3401/022, Accessories for Rectangular Connectors 3401/001, 3401/002 and Connector Savers 3401/020, 3401/080.
- (d) ESCC Detail Specification No. 3401/072, Lightweight Accessories for Rectangular Connectors 3401/001 and 3401/002.
- (e) ESCC Detail Specification No. 3401/085, Fast-Locking Screw Lock Assemblies for Rectangular Connectors 3401/001, 3401/002 and Connector Savers 3401/020, 3401/080.
- (f) MIL-DTL-24308, Rack and Panel Connectors, Miniature.

3 TERMS, DEFINITIONS, ABBREVIATIONS, SYMBOLS AND UNITS

For the purpose of this specification, the terms, definitions, abbreviations, symbols and units specified in ESCC Basic Specification No. 21300 shall apply.

TABLE 1(a) – TYPE VARIANTS

Variant	Shell Size (2)	Max. Weight (g) (1)		Max Weight With Grommet (g) (2)		Mating Force (N. max)	Unmating Force	
		Male	Female	Male	Female		N. min	N. max
01 (Gauge 20 Contacts)	E	5.5	6	6.5	7	30	3.5	20
	A	7.6	8.3	9	9.7	50	4.5	34
	B	12.5	13.6	14.6	15.7	83	8	55
	C	17.4	18.9	20.4	21.9	123	11	83
	D	20.5	22.3	24	25.8	166	14.5	120
02 (Gauge 22 Contacts)	E	5.2	6	6.15	6.95	46	3.4	28
	A	7.4	8	8.7	9.3	77	4.5	46
	B	11	12	13	14	127	7.9	77
	C	15.6	17	18.35	19.75	177	11.3	109
	D	18.2	20	21.6	23.4	222	14.7	136
	F	23	25	-	-	295	20.3	177

NOTES

- 1. For connectors without contacts and without rear grommet, but see Para. 4.5.4.10. See ESCC Detail Specification No. 3401/005 for contact weights.
- 2. For connectors with rear grommet, without contacts, but see Para. 4.5.4.10. See ESCC Detail Specification No. 3401/005 for contact weights.

TABLE 1(b) MAXIMUM RATINGS

No.	Characteristics	Symbol	Maximum Rating		Unit
			Min	Max	
1	Working Voltage (Sea Level)	U_R			
	Variant 01		-	300	Vrms
	Variant 02		-	250	Vrms
2	Operating Temperature Range	T_{op}	-55	+125	°C
3	Storage Temperature Range	T_{stg}	-65	+125	°C

FIGURE 1 - PARAMETER DERATING INFORMATION

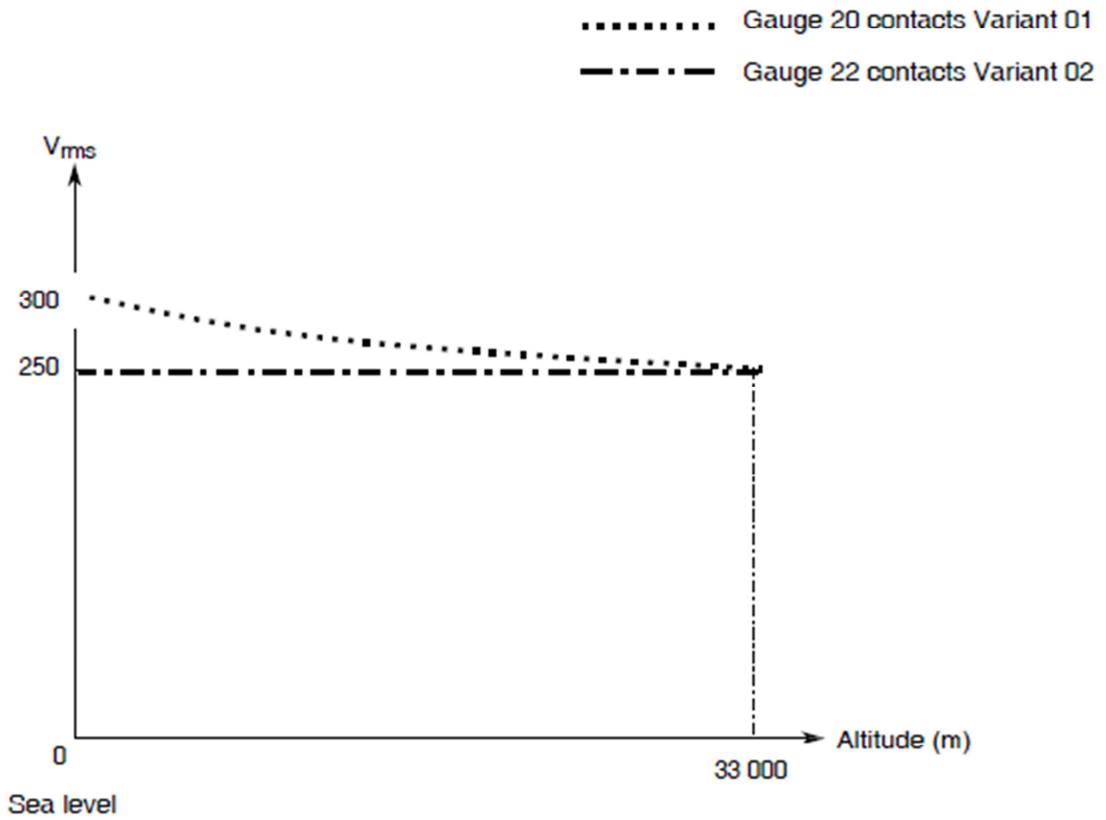

FIGURE 2 – PHYSICAL DIMENSIONS

FIGURE 2(a) - RECEPTACLES AND PLUGS

SHELL SIZE E

STANDARD MOUNTING HOLES

FIXED MOUNT

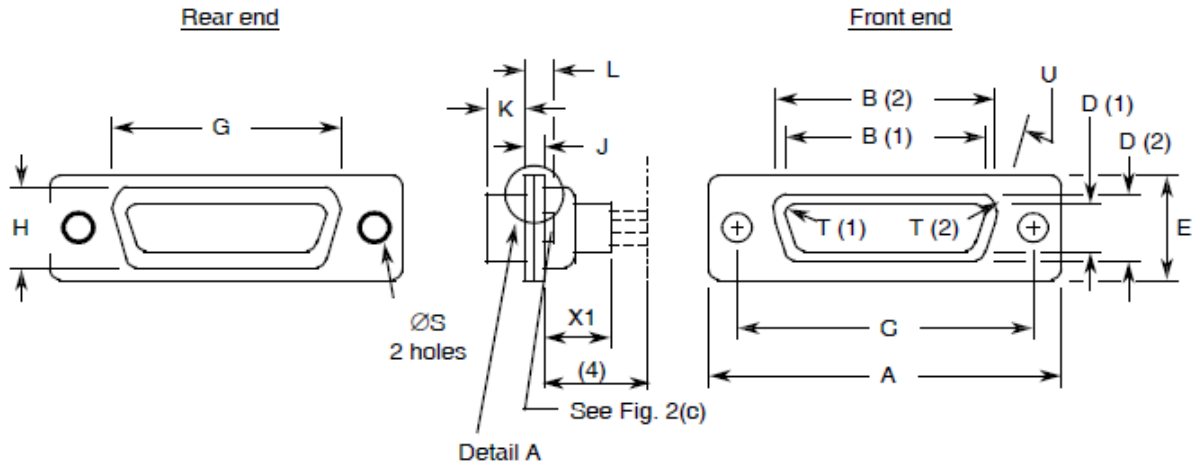

REAR GROMMET VERSION

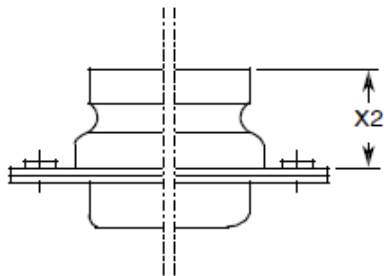

DETAIL A

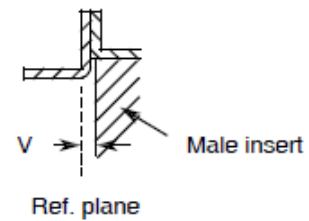

Contact Type	Connector Type	Symbol/ Dim.	A	<u>B</u>	<u>C</u>	<u>D</u>	E	G	H	J	<u>K</u>	L	ØS	<u>I</u>	<u>U</u>	<u>V</u>	X1	X2
Male	Plug	Min	30.43	16.79	24.87	8.23	12.17	19.02	10.46	0.51	5.82	0.89	2.92	2.59	9	0	-	-
		Max	31.19	17.04	25.12	8.48	12.93	19.53	10.97	1.02	6.05	1.52	3.2	2.69	11	0.4	9.53	15.18
Female	Receptacle	Min	30.43	16.21	24.87	7.77	12.07	19.02	10.46	0.51	6.05	0.89	2.92	2.46	9	-	-	-
		Max	31.19	16.46	25.12	8.03	12.93	19.53	10.97	1.02	6.3	1.52	3.2	2.62	11	-	-	9.53

NOTES

1. Inside dimension for connectors with male contacts.
2. Outside dimension for connectors with female contacts.
3. All dimensions are in millimetres (angles in degrees).
4. Contacts 340100505B and 340100506B protrude 16.5mm maximum.
5. Underlined dimensions, in table, are critical to ensure intermateability.

SHELL SIZE A
STANDARD MOUNTING HOLES
FIXED MOUNT

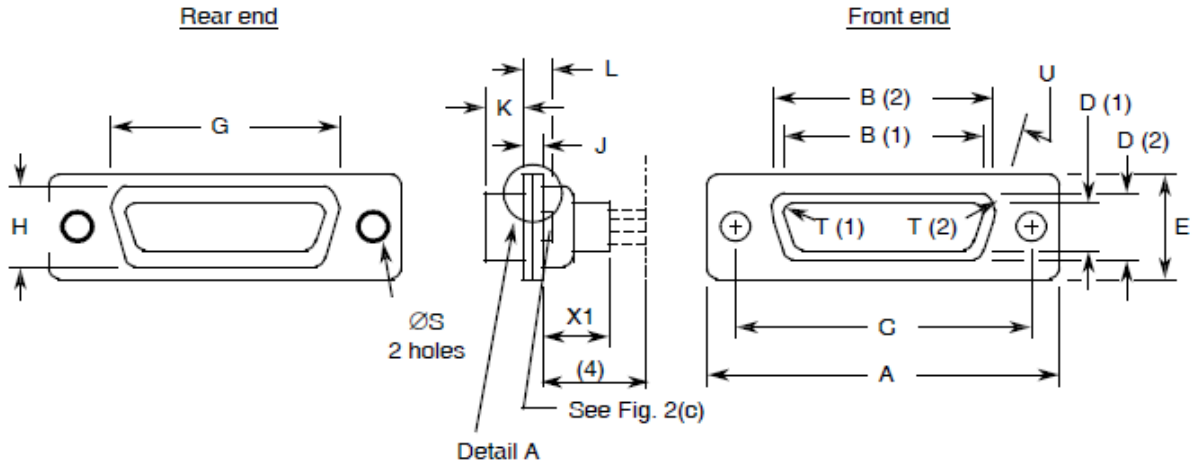

REAR GROMMET VERSION

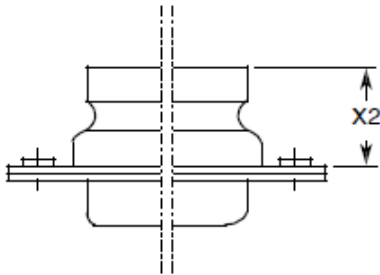

DETAIL A

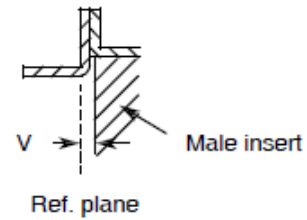

Contact Type	Connector Type	Symbol/Dim.	<u>A</u>	<u>B</u>	<u>C</u>	<u>D</u>	E	G	H	J	<u>K</u>	L	ØS	<u>I</u>	<u>U</u> °	V	X1	X2
Male	Plug	Min	38.76	25.12	33.2	8.23	12.17	27.25	10.46	0.51	5.82	0.89	2.92	2.59	9	0	-	-
		Max	39.52	25.37	33.45	8.48	12.93	27.76	10.97	1.02	6.05	1.52	3.2	2.69	11	0.4	9.53	15.18
Female	Receptacle	Min	38.76	24.54	33.2	7.77	12.17	27.25	10.46	0.51	6.05	0.89	2.92	2.46	9	-	-	-
		Max	39.52	24.79	33.45	8.03	12.93	27.76	10.97	1.02	6.3	1.52	3.2	2.62	11	-	9.53	15.18

NOTES

1. Inside dimension for connectors with male contacts.
2. Outside dimension for connectors with female contacts.
3. All dimensions are in millimetres (angles in degrees).
4. Contacts 340100505B and 340100506B protrude 16.5mm maximum.
5. Underlined dimensions, in table, are critical to ensure intermateability.

SHELL SIZE B
STANDARD MOUNTING HOLES
FIXED MOUNT

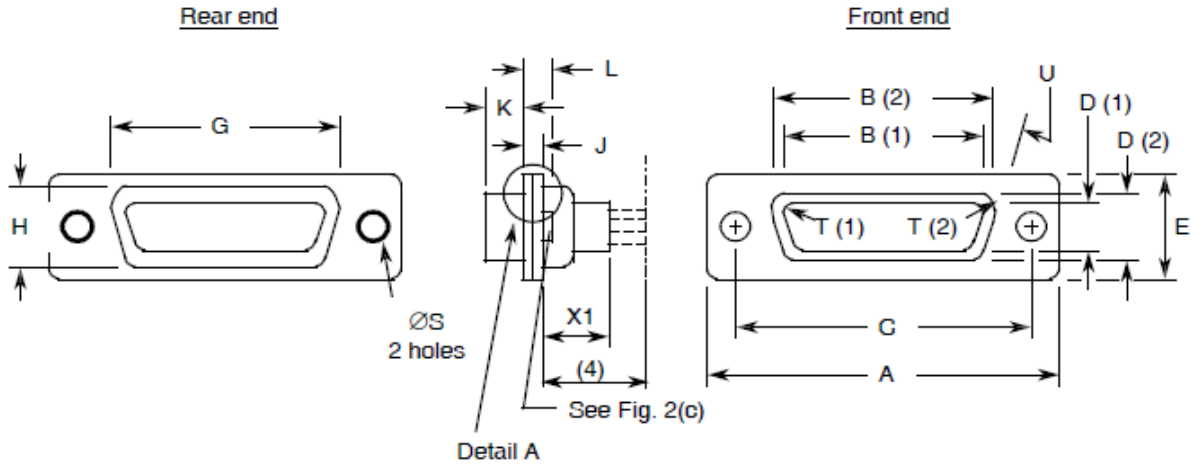

REAR GROMMET VERSION

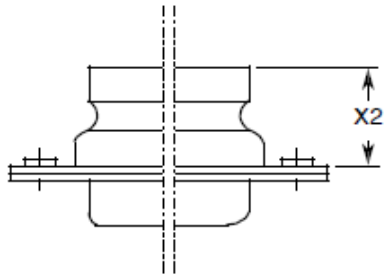

DETAIL A

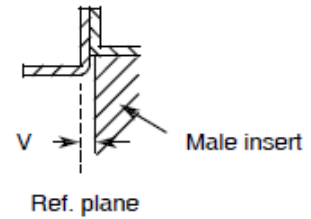

Contact Type	Connector Type	Symbol/Dim.	A	<u>B</u>	<u>C</u>	<u>D</u>	E	G	H	J	<u>K</u>	L	$\varnothing S$	<u>I</u>	<u>U</u>	V	X1	X2
Male	Plug	Min	52.65	38.84	46.91	8.23	12.17	41.02	10.46	0.51	5.69	1.05	2.92	2.59	9	0	-	-
		Max	53.42	39.09	47.17	8.48	12.93	41.53	10.97	1.24	5.99	1.78	3.2	2.69	11	0.6	9.53	15.18
Female	Receptacle	Min	52.65	38.25	46.91	7.77	12.17	41.02	10.46	0.51	6.05	0.89	2.92	2.46	9	-	-	-
		Max	53.42	38.51	47.17	8.03	12.93	41.53	10.97	1.02	6.3	1.52	3.2	2.62	11	-	9.53	15.18

NOTES

1. Inside dimension for connectors with male contacts.
2. Outside dimension for connectors with female contacts.
3. All dimensions are in millimetres (angles in degrees).
4. Contacts 340100505B and 340100506B protrude 16.5mm maximum.
5. Underlined dimensions, in table, are critical to ensure intermateability.

SHELL SIZE C
STANDARD MOUNTING HOLES
FIXED MOUNT

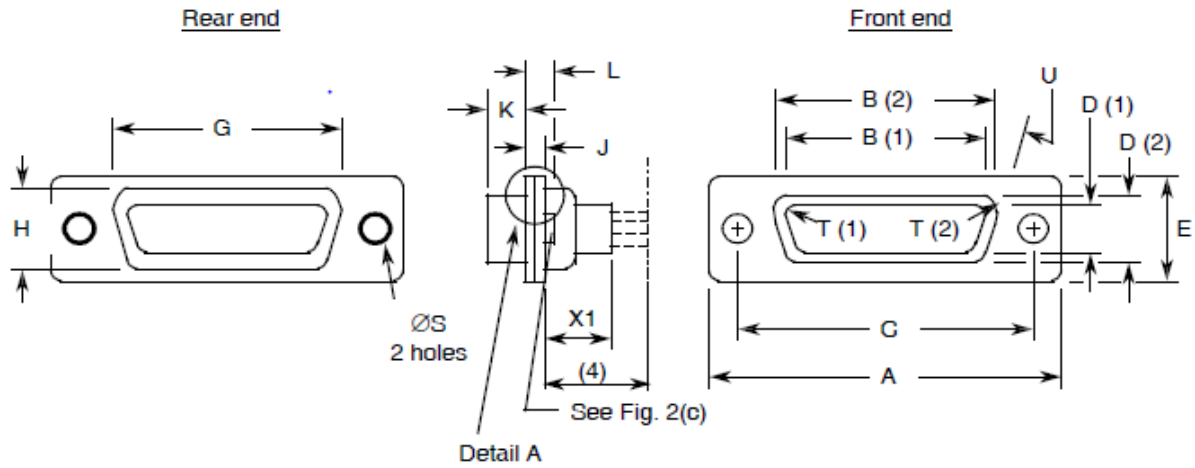

REAR GROMMET VERSION

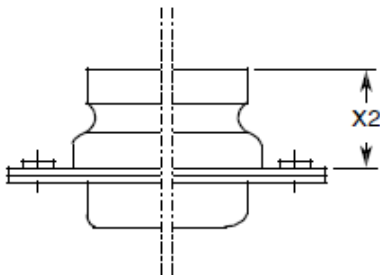

DETAIL A

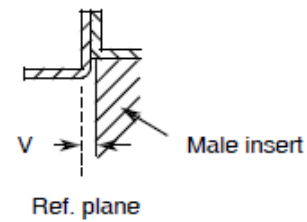

Contact Type	Connector Type	Symbol/Dim.	A	<u>B</u>	<u>C</u>	<u>D</u>	E	G	H	J	<u>K</u>	L	$\varnothing S$	<u>I</u>	<u>U</u> °	V	X1	X2
Male	Plug	Min	68.94	55.3	63.37	8.23	12.17	57.45	10.46	0.51	5.69	1.05	2.92	2.59	9	0	-	-
		Max	69.7	55.55	63.63	8.48	12.93	57.96	10.97	1.24	5.99	1.78	3.2	2.69	11	0.6	9.53	15.18
Female	Receptacle	Min	68.94	54.71	63.37	7.77	12.17	57.45	10.46	0.51	6.05	0.89	2.92	2.46	9	-	-	-
		Max	69.7	54.97	63.63	8.03	12.93	57.96	10.97	1.02	6.3	1.52	3.2	2.62	11	-	9.53	15.18

NOTES

1. Inside dimension for connectors with male contacts.
2. Outside dimension for connectors with female contacts.
3. All dimensions are in millimetres (angles in degrees).
4. Contacts 340100505B and 340100506B protrude 16.5mm maximum.
5. Underlined dimensions, in table, are critical to ensure intermateability.

SHELL SIZE D
STANDARD MOUNTING HOLES
FIXED MOUNT

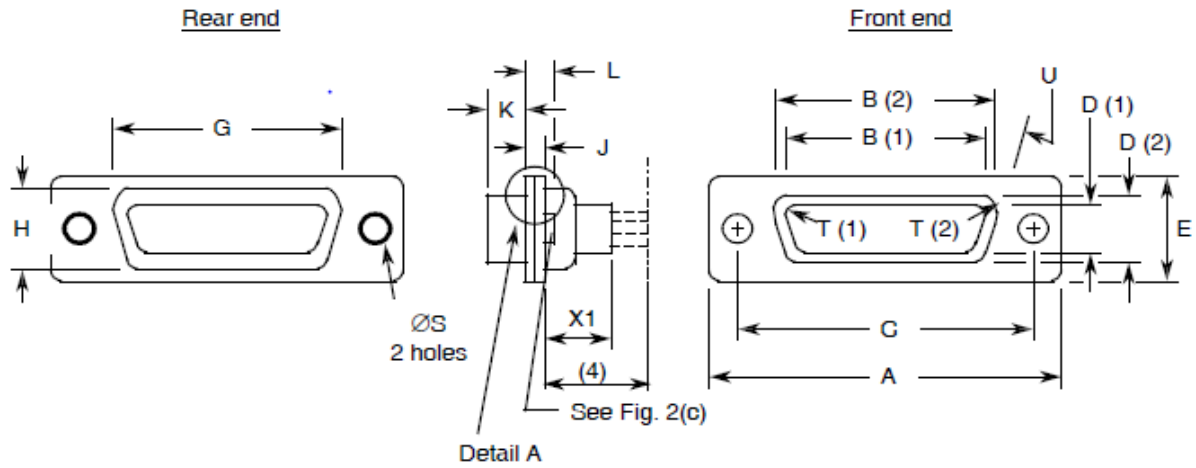

REAR GROMMET VERSION

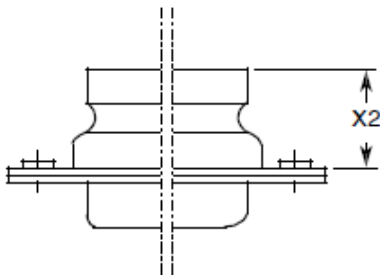

DETAIL A

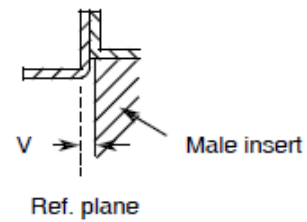

Contact Type	Connector Type	Symbol/Dim.	<u>A</u>	<u>B</u>	<u>C</u>	<u>D</u>	E	G	H	J	<u>K</u>	L	ØS	<u>I</u>	<u>U</u>	V	X1	X2
Male	Plug	Min	66.55	52.68	60.99	10.95	14.99	55.07	13.31	0.51	5.69	1.05	2.92	2.59	9	0	-	-
		Max	67.31	52.93	61.24	11.07	15.75	55.58	13.82	1.24	5.99	1.78	3.2	2.69	11	0.6	9.53	15.18
Female	Receptacle	Min	66.55	52.3	60.99	10.62	14.99	55.07	13.31	0.51	6.05	0.89	2.92	2.46	9	-	-	-
		Max	67.31	52.55	61.24	10.87	15.75	55.58	13.82	1.02	6.3	1.52	3.2	2.62	11	-	9.53	15.18

NOTES

1. Inside dimension for connectors with male contacts.
2. Outside dimension for connectors with female contacts.
3. All dimensions are in millimetres (angles in degrees).
4. Contacts 340100505B and 340100506B protrude 16.5mm maximum.
5. Underlined dimensions, in table, are critical to ensure intermateability.

SHELL SIZE F
STANDARD MOUNTING HOLES
FIXED MOUNT

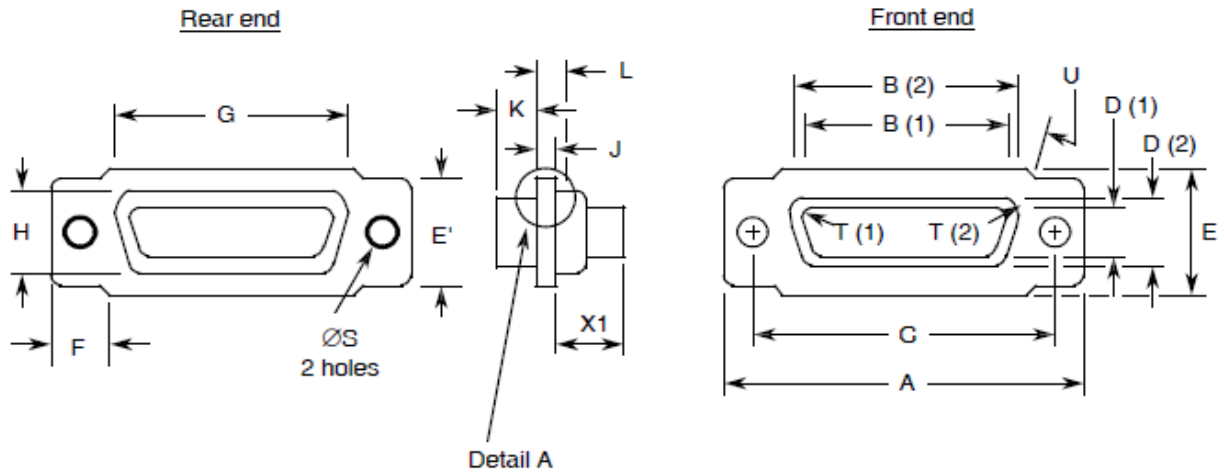

DETAIL A

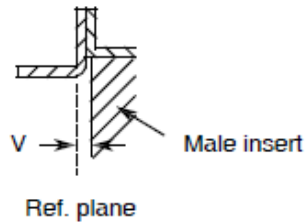

Contact Type	Connector Type	Symbol/Dim.	A	<u>B</u>	<u>C</u>	<u>D</u>	E	E'	F	G	H	J	<u>K</u>	$\varnothing S$	<u>I</u>	<u>U</u> °	<u>V</u>	X1
Male	Plug	Min	68.94	56.06	63.37	12.65	16.92	14.99	5.17	57.25	15.45	0.74	5.69	2.92	2.59	9	0	-
		Max	69.7	56.31	63.63	12.9	17.68	15.75	5.43	57.75	15.95	1.24	5.99	3.2	2.69	11	0.6	9.53
Female	Receptacle	Min	68.94	55.47	63.37	12.19	16.92	14.99	5.17	57.25	15.45	0.51	6.05	2.92	2.46	9	-	-
		Max	69.7	55.73	63.63	12.45	17.68	15.75	5.43	57.75	15.95	1.02	6.3	3.2	2.62	11	-	9.53

NOTES

1. Inside dimension for connectors with male contacts.
2. Outside dimension for connectors with female contacts.
3. All dimensions are in millimetres (angles in degrees).
4. Underlined dimensions, in table, are critical to ensure intermateability.

FIGURE 2(b) - CONTACT ARRANGEMENTS

VARIANT 01 - STANDARD CONTACT ARRANGEMENTS

FRONT VIEW MALE INSERT

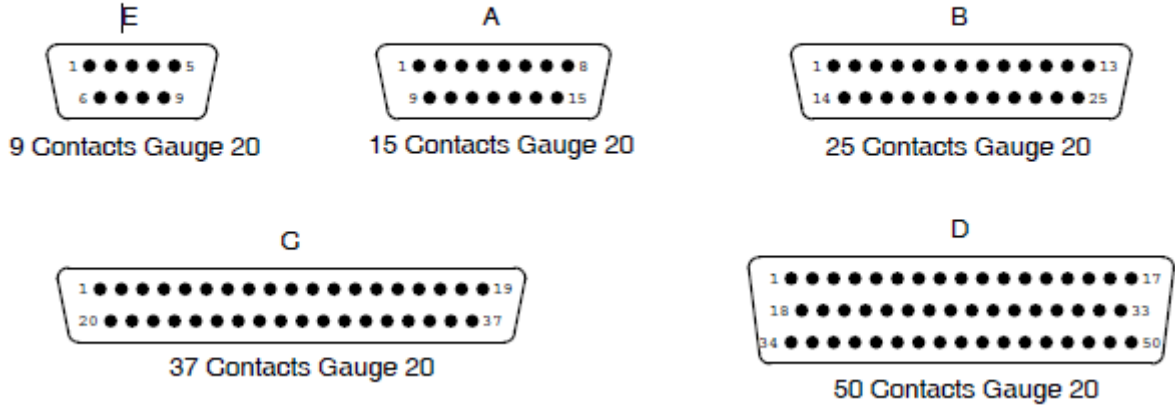

VARIANT 02 - HIGH DENSITY CONTACT ARRANGEMENTS

FRONT VIEW MALE INSERT

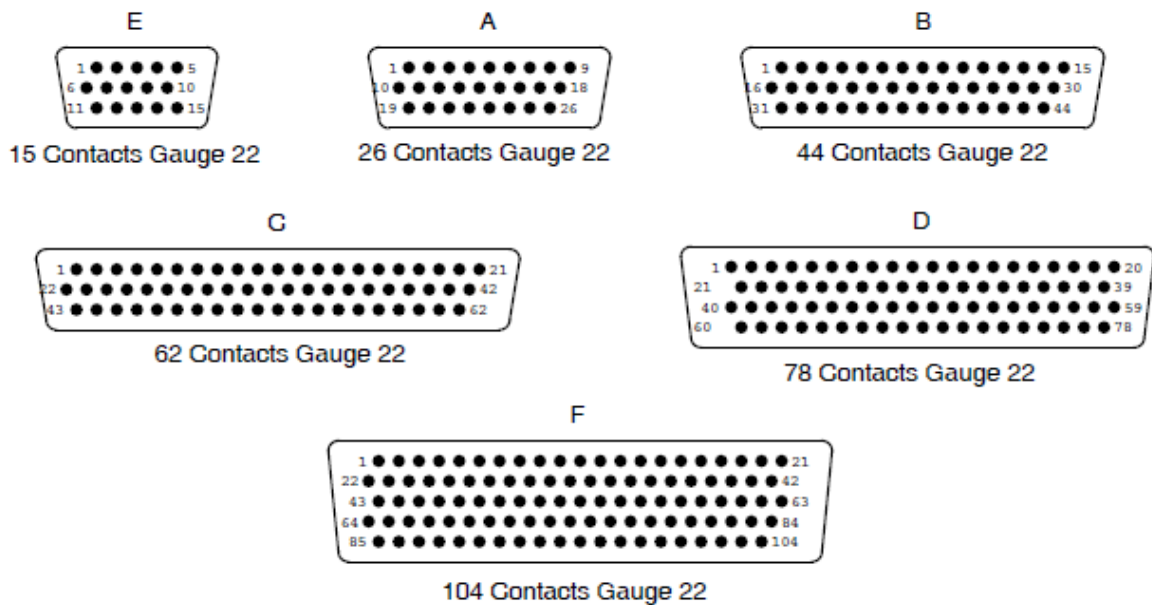

NOTES

- Contact locations are in conformity with MIL-DTL-24308 specification sheets and shall not be checked during procurement.
- Both sides of the insert shall be marked with the minimum marking shown.

FIGURE 2(c) - RECEPTACLES AND PLUGS

OTHER MOUNTING TYPES

FLOATING MOUNT - TYPE 'Y'

SHELL SIZES E, A, B, C, D AND F

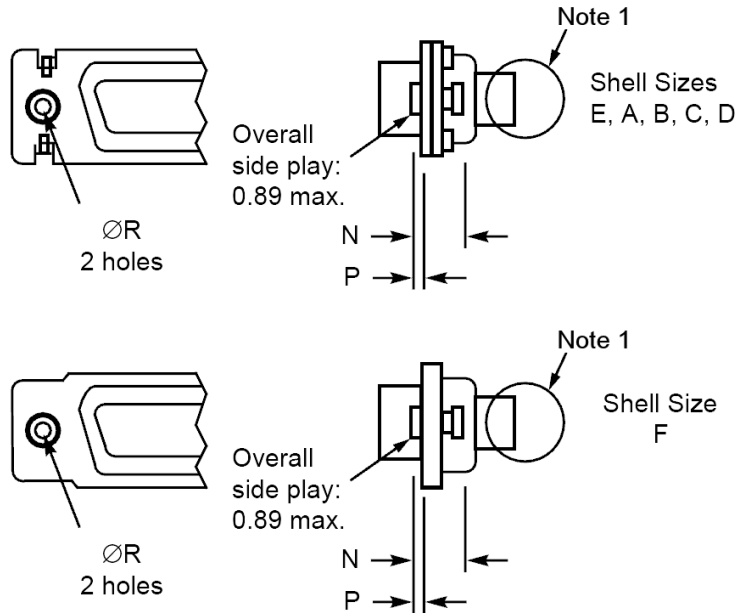

Contact Type	Symbol/ Dim.	N	P	ØR
Male	Min.	2.4	0.76	2.2
	Max.	3.3	0.86	2.3
Female	Min.	2.4	0.76	2.2
	Max.	3.3	0.86	2.3

CAPTIVE NUT - TYPE 'E'

SHELL SIZES E, A, B, C AND D

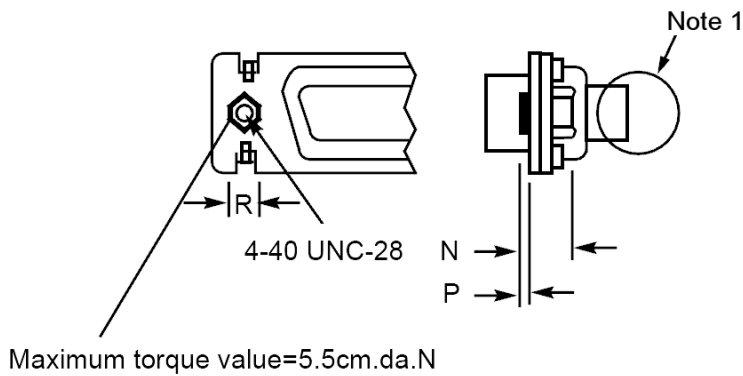

Contact Type	Symbol/ Dim.	N	P	R
Male	Min.	3.4	0	4.3
	Max.	4.2	0.4	4.7
Female	Min.	3.4	0	4.3
	Max.	4.2	0.4	4.7

NOTES

1. See Figure 2(a) for other dimensions.

4 REQUIREMENTS

4.1 GENERAL

The complete requirements for procurement of the connectors specified herein are stated in this specification and ESCC Generic Specification No. 3401. Deviations from the Generic Specification, applicable to this specification only, are listed in Para. 4.2.

Deviations from the applicable Generic Specification and this Detail Specification, formally agreed with specific Manufacturers on the basis that the alternative requirements are equivalent to the ESCC requirements and do not affect the components' reliability, are listed in the appendices attached to this specification..

4.2 DEVIATIONS FROM GENERIC SPECIFICATION

4.2.1 Deviations from Special In-process Controls

None.

4.2.2 Deviations from Final Production Tests (Chart II)

(a) Para. 9.1.1.4, Mated Shell Conductivity: Not applicable.

4.2.3 Deviations from Burn-in and Electrical Measurements (Chart III)

Not applicable.

4.2.4 Deviations from Qualification Tests (Chart IV)

- (a) Para. 9.1.1.4, Mated Shell Conductivity: Not applicable.
- (b) Para. 9.9, Seal Test: Not applicable.
- (c) Para. 9.24, Jackscrew Retention: Not applicable.

4.2.5 Deviations from Lot Acceptance Tests (Chart V)

- (a) Para. 9.1.1.4, Mated Shell Conductivity: Not applicable.
- (b) Para. 9.9, Seal Test: Not applicable.

4.3 MECHANICAL REQUIREMENTS

4.3.1 Dimension Check

The dimensions of the connectors specified herein shall be verified in accordance with the requirements set out in Para. 9.6 of ESCC Generic Specification 3401 and shall conform to those shown in Figure 2 of this specification. Only the underlined dimensions shall be checked during procurement.

4.3.2 Weight

The maximum weight of the connectors specified herein, without contacts, shall be as specified in Table 1(a).

4.3.3 Contact Capability

As specified in ESCC Detail Specification No. 3401/005.

4.3.4 Contact Retention (In Insert)

As specified in ESCC Detail Specification No. 3401/005.

4.3.5 Mating and Unmating Forces

The forces applied for mating and unmating of the connectors shall conform to the values specified in Table 1(a).

4.3.6 Insert Retention (In Shell)

Connector inserts shall withstand a pressure of 42.8N/cm^2 without being dislodged from the shell.

4.3.7 Jackscrew Retention

Not applicable.

4.3.8 Contact Insertion and Withdrawal Forces

As specified in ESCC Detail Specification No. 3401/005.

4.3.9 Engagement and Separation Forces

As specified in ESCC Detail Specification No. 3401/005.

4.3.10 Oversize Pin Exclusion

As specified in ESCC Detail Specification No. 3401/005.

4.3.11 Probe Damage

As specified in ESCC Detail Specification No. 3401/005.

4.3.12 Solderability

As specified in ESCC Detail Specification No. 3401/005.

4.4 MATERIALS AND FINISHES

The materials and finishes shall be as specified herein. Where a definite material is not specified, a material which will enable the connectors specified herein to meet the performance requirements of this specification shall be used. Acceptance or approval of any constituent material does not guarantee acceptance of the finished product.

4.4.1 Shells

Shells of shell sizes E, A, B, C and D shall be made of brass. The plating shall be $0.7\mu\text{m}$ minimum of gold over $1\mu\text{m}$ minimum of copper.

Shells of shell size F shall be made of aluminium alloy. The plating shall be either $25.4\mu\text{m}$ minimum of electroless nickel (Modification Code A174) or $0.7\mu\text{m}$ minimum of gold with $25.4\mu\text{m}$ minimum electroless nickel underplating (Modification Code FR172).

4.4.2 Inserts

Inserts shall be made of glass-fibre filled diallylphthalate resin or a suitable thermoplastic material. The rear grommet shall be made of silicone elastomer.

4.4.3 Contacts

As specified in ESCC Detail Specification No. 3401/005.

4.4.4 Contact Retaining Clip

The retaining clip shall be made of beryllium copper.

4.4.5 Guiding and Locking Devices

As specified in ESCC Detail Specification Nos. 3401/022, 3401/072 and 3401/085

4.4.6 Magnetism Level

The allowable value of magnetism shall not exceed that specified for the relevant level (see Para. 4.5.4.8). Only magnetism levels NMC and NMD are verified.

4.5 MARKING

4.5.1 General

The marking of components delivered to this specification shall be in accordance with the requirements of ESCC Basic Specification No. 21700 and the following paragraphs. When the component is too small to accommodate all of the marking specified, as much as space permits shall be marked and the marking information, in full, shall accompany the component in its primary package.

The information to be marked and the order of precedence, shall be as follows:-

- (a) Contact Identification.
- (b) The ESCC Component Number.
- (c) Characteristics.
- (d) Traceability Information.

4.5.2 Contact Identification

Contact identification shall be marked in accordance with Figure 2.

4.5.3 The ESCC Component Number

Each component shall bear the ESCC Component Number which shall be constituted and marked as follows:

Example: 340100201B

- Detail Specification Number: 3401002
- Type Variant (see Table 1(a)): 01
- Testing level: B

4.5.4 Characteristics

The characteristics to be marked in the following order of precedence are:

- (a) Series.
- (b) Shell size.
- (c) Insert type.
- (d) Alternative designs.
- (e) Contact arrangement.
- (f) Type of contact.
- (g) Magnetism Level.
- (h) Modification Code.
- (i) Contact information

The information shall be constituted and marked as follows:

Example: DF MAY-104S-NMC-A174-FO

- Series: D
- Shell size: F
- Insert type: MA
- Alternative designs (floating mounts): Y
- Contact arrangement: 104
- Type of contact (female): S
- Magnetism Level (20 gamma): NMC
- Modification Code (electroless nickel finish): A174
- Contact information: FO

4.5.4.2 *Series*

This connector series shall be designated by the letter 'D'.

4.5.4.3 *Shell Size*

The shell size shall be indicated by the letters specified hereafter.

Code	E	A	B	C	D	F
------	---	---	---	---	---	---

4.5.4.4 *Insert Type*

This connector type with crimp contacts is defined by the letters 'MA'.

4.5.4.5 *Alternative Designs*

- The letter 'E' indicates captive nuts.
- The letter 'Y' indicates floating mounts.
- The letter 'G' indicates a rear grommet dust proof version.
- The letters 'YG' indicate floating mounts and rear grommet dust proof version.

If the shell has standard mounting holes, these letters shall be omitted.

4.5.4.6 *Contact Arrangements*

The number of contacts shall be as shown in Figure 2(b) and contact arrangements shall be indicated by the codes specified hereafter.

Shell Size	Code	
	Variant 01	Variant 02
E	9	15
A	15	26
B	25	44
C	37	62
D	50	78
F	-	104

4.5.4.7 *Type of Contact*

The contact types shall be indicated by the following code letters.

Code Letter	Contact Type
P	Male
S	Female

4.5.4.8 *Magnetism Level*

The following codes shall be used for magnetism level.

Code	Definition
NMB	Magnetism Level: ≤ 200 gamma (1)
NMC	Magnetism Level: ≤ 20 gamma
NMD	Magnetism Level: ≤ 2 gamma

NOTES

1. Guaranteed, but not measured.

4.5.4.9 *Modification Code*

The modification code for the finish of shell size F (aluminium alloy) shall be:

- A174 for the electroless nickel finish
- FR172 for the gold over electroless nickel finish.

The modification code shall be omitted for shell sizes E, A, B, C and D.

4.5.4.10 *Contact Information*

FO = Connector ordered without contacts. This information shall be only marked on the packaging and is not marked on the connector.

Contacts must be from the same Manufacturer as the connector in which they are mounted and this shall be verified prior to assembly.

4.5.5 Traceability Information

Traceability information shall be marked in accordance with the requirements of ESCC Basic Specification No. 21700.

4.6 ELECTRICAL MEASUREMENTS

4.6.1 Electrical Measurements at Room Temperature

The parameters to be measured in respect of electrical characteristics are scheduled in Table 2. Unless otherwise specified, these measurements shall be performed at $T_{amb} = +22 \pm 3^{\circ}\text{C}$.

4.6.2 Electrical Measurements at High and Low Temperatures (Table 3)

Not applicable.

4.6.3 Circuits for Electrical Measurements (Figure 4)

Not applicable.

4.7 BURN-IN AND ELECTRICAL MEASUREMENTS (TABLES 4 AND 5)

Not applicable.

4.8 ENVIRONMENTAL AND ENDURANCE TESTS

4.8.1 Measurements and Inspections on Completion of Environmental Tests

The parameters to be measured and inspections to be performed on completion of environmental testing shall be those specified in Table 6. Unless otherwise specified, the measurements shall be performed at $T_{amb} = +22 \pm 3^{\circ}\text{C}$.

4.8.2 Measurements and Inspections at Intermediate Points during Endurance Tests

Not applicable.

4.8.3 Measurements and Inspections on Completion of Endurance Tests

The parameters to be measured and inspections to be performed on completion of endurance tests shall be those specified in Table 6. Unless otherwise specified, the measurements shall be performed at $T_{amb} = +22 \pm 3^{\circ}\text{C}$.

4.8.4 Conditions for Operating Life Test (Part of Endurance Testing)

Not applicable.

4.8.5 Electrical Circuits for Operating Life Test

Not applicable.

4.8.6 Conditions for High Temperature Storage Test (Part of Endurance Testing)

The requirements for the high temperature storage test are specified in Section 9 of ESCC Generic Specification No. 3401. The conditions for high temperature storage testing shall be the maximum storage temperature specified in Table 1(b) of this specification.

TABLE 2 – ELECTRICAL MEASUREMENTS AT ROOM TEMPERATURE

No.	Characteristic	Symbol	Specification and Test Method	Test Condition	Limits		Unit
					Min	Max	
1	Insulation Resistance	Ri	ESCC 3401 Para. 9.1.1.1	Para. 9.1.1.1	5000	-	MΩ
2	Voltage Proof Leakage Current Variant 01 Variant 02	I _L	ESCC 3401 Para. 9.1.1.2	1250Vrms (1) 1000Vrms	- -	2 2	mA
3	Mated Shell Conductivity (Voltage Drop) (2)	Vd	ESCC 3401 Para. 9.1.1.4	Para. 9.1.1.3	Not applicable		mV

NOTES

1. When connectors are equipped with 340100505B or 340100506B contacts, each crimp barrel shall be isolated from adjacent contacts with insulation material.
2. Applicable to mated connectors with grounding option.

TABLES 3, 4 AND 5

Not applicable.

TABLE 6 – MEASUREMENTS AND INSPECTIONS ON COMPLETION OF ENVIRONMENTAL AND ENDURANCE TESTING

No.	ESCC Generic Spec. No. 3401		Measurements and Inspections		Symbol	Limits		Unit
	Environmental and Endurance Tests (1)	Test Method and Conditions	Identification	Conditions		Min	Max	
01	Wiring	Para. 9.10	ESCC 3401/005	-	-	-	-	
02	Vibration	Para. 9.11	Initial Measurements Coupling Screw(s) Unlocking Torque Final Measurements Coupling Screw(s) Unlocking Torque Drift Visual Examination	- Full Engagement - - -	- Δ -	Record Values -25 +25 - -		%
03	Shock or Bump	Para. 9.12	Final Measurements Visual Examination	Full Engagement -	- -	- -	- -	

No.	ESCC Generic Spec. No. 3401		Measurements and Inspections		Symbol	Limits		Unit
	Environmental and Endurance Tests (1)	Test Method and Conditions	Identification	Conditions		Min	Max	
04	Climatic Sequence	Para. 9.13	Dry Heat	Table 2 Item 1	Ri	1000	-	MΩ
			Insulation Resistance					
			Low Air Pressure	Figure 1	I _L	Table 2 Item 2		
			Voltage Proof Leakage Current					
			Damp Heat	Immediately after test	Ri	100	-	MΩ
			Insulation Resistance					
After 1 - 24hrs Recovery	ESCC 3401 Para. 9.7	-	ESCC 3401 Para. 9.7					
External Visual Inspection								
Insulation Resistance	Table 2 Item 1	Ri	Table 2 Item 1					
Voltage Proof Leakage Current	Table 2 Item 2	I _L	Table 2 Item 2					
05	Seal Test	Para. 9.9	ESCC 3401 Para. 9.9	-	-	Not applicable		
06	Plating Thickness	Para. 9.14	Thickness	-	-	ESCC 3401/005		
07	Joint Strength	Para. 9.15	ESCC 3401 Para. 9.15	-	-	ESCC 3401 Para. 9.15		
08	Rapid Change of Temperature	Para. 9.16	Visual Examination	-	-	-	-	
			Insulation Resistance	Table 2 Item 1	Ri	Table 2 Item 1		
			Voltage Proof Leakage Current	Table 2 Item 2	I _L	Table 2 Item 2		
09	Contact Retention (In Insert)	Para. 9.17 & Para. 4.3.4 of this spec	Contact Displacement	-	-	ESCC 3401 Para. 9.17		
10	Endurance	Para. 9.18	Initial Measurements	-	F	Para. 4.3.5 of this spec.	Record Values	
			Mating/Unmating Forces					
			Low Level Contact Resistance					ESCC 3401/005
			Mated Shell Conductivity	Table 2 Item 3	Vd	Not applicable		
			Final Measurements	-	-	-	-	
			Visual Examination					
			Mating/Unmating Forces					-
			Low Level Contact Resistance Drift	ESCC 3401/005	ΔRcl	ESCC 3401/005		
			Mated Shell Conductivity	Table 2 Item 3	Vd	Not applicable		
			Insulation Resistance	Table 2 Item 1	Ri	Table 2 Item 1		
Voltage Proof Leakage Current	Table 2 Item 2	I _L	Table 2 Item 2					

No.	ESCC Generic Spec. No. 3401		Measurements and Inspections		Symbol	Limits		Unit
	Environmental and Endurance Tests (1)	Test Method and Conditions	Identification	Conditions		Min	Max	
11	Permanence of Marking	Para. 9.19	As applicable	-	-	-	-	
12	Mating Unmating Forces	Para. 9.20	Force	-	F	Para. 4.3.5 of this spec.		
13	High Temperature Storage	Para. 9.21	Initial Measurements					
			Low Level Contact Resistance	ESCC 3401/005	Rcl	Record Values		
			Mated Shell Conductivity	Table 2 Item 3	Vd	Not applicable		
			Final Measurements					
			Visual Examination	-	-	-	-	
			Mating/Unmating Forces	-	F	Para. 4.3.5 of this spec.		
			Low Level Contact Resistance Drift	ESCC 3401/005	ΔRcl	ESCC 3401/005		
			Rated Current Contact Resistance	ESCC 3401/005	Rcr	ESCC 3401/005		
			Mated Shell Conductivity	Table 2 Item 3	Vd	Not applicable		
			Insulation Resistance	Table 2 Item 1	Ri	Table 2 Item 1		
Voltage Proof Leakage Current	Table 2 Item 2	IL	Table 2 Item 2					
Contact Retention (In Insert)	Para. 4.3.4 of this spec.	-	ESCC 3401 Para. 9.17					
14	Corrosion	Para. 9.22	Visual Examination	-	-	-	-	
15	Insert Retention (In Shell)	Para. 9.23 & Para. 4.3.6 of this spec.	Visual Examination	-	-	Para. 4.3.6		
16	Jackscrew Retention	Para. 9.24 & Para. 4.3.7 of this spec.	Visual Examination	-	-	Not applicable		
17	High Temperature Measurements	Para. 9.25	Insulation Resistance	Table 2 Item 1	Ri	500	-	MΩ
18	Overload Test	Para. 9.26	Internal Temperature	-	T	-	+100	°C
			Rated Current Contact Resistance	ESCC 3401/005	Rcr	ESCC 3401/005		
			Mated Shell Conductivity	Table 2 Item 3	Vd	Not applicable		
			Insulation Resistance	Table 2 Item 1	Ri	Table 2 Item 1		
			Voltage Proof Leakage Current	Table 2 Item 2	IL	Table 2 Item 2		
19	Maintenance Ageing	Para. 9.27	Visual Examination	-	-	-	-	
			Contact Retention	Para. 4.3.4 of this spec.	-	ESCC 3401 Para. 9.17		
			Contact Insertion & Withdrawal Forces	Para. 4.3.8 of this spec.	-	Para. 4.3.8		
20	Engage/Separation Forces	Para. 9.28 & Para. 4.3.9 of this spec.	Force	-	-	Para. 4.3.9		

No.	ESCC Generic Spec. No. 3401		Measurements and Inspections		Symbol	Limits		Unit
	Environmental and Endurance Tests (1)	Test Method and Conditions	Identification	Conditions		Min	Max	
21	Oversize Pin Exclusion	Para. 9.29 & Para. 4.3.10 of this spec.	-	-	-	ESCC 3401 Para. 9.29		
22	Probe Damage	Para. 9.30 & Para. 4.3.11 of this spec.	Contact Separation Force	Para. 4.3.9 of this spec.		Para. 4.3.9		
23	Solderability	Para. 9.31 & Para. 4.3.12 of this spec.	-	-	-	Para. 4.3.12		

NOTES

1. The tests in this Table refer to either Chart IV or V and shall be used as applicable.

APPENDIX A
AGREED DEVIATIONS FOR C & K COMPONENTS (F)

ITEMS AFFECTED	DESCRIPTION OF DEVIATIONS
Para. 4.2.2	Para. 9.3, Contact Retainer Test may be omitted provided that a 100% external visual inspection of the contact retainer clips positioned within the insert is performed in accordance with the C & K COMPONENTS PID requirements.