



Pages 1 to 25

INTEGRATED CIRCUITS, SILICON MONOLITHIC, CMOS

DECADE COUNTER/DIVIDER

WITH FULLY BUFFERED OUTPUTS

BASED ON TYPE 4017B

ESCC Detail Specification No. 9204/020

Issue 4	July 2009
---------	-----------



Document Custodian: European Space Agency - see <https://escies.org>

LEGAL DISCLAIMER AND COPYRIGHT

European Space Agency, Copyright © 2009. All rights reserved.

The European Space Agency disclaims any liability or responsibility, to any person or entity, with respect to any loss or damage caused, or alleged to be caused, directly or indirectly by the use and application of this ESCC publication.

This publication, without the prior permission of the European Space Agency and provided that it is not used for a commercial purpose, may be:

- copied in whole, in any medium, without alteration or modification.
- copied in part, in any medium, provided that the ESCC document identification, comprising the ESCC symbol, document number and document issue, is removed.

DOCUMENTATION CHANGE NOTICE

(Refer to <https://escies.org> for ESCC DCR content)

DCR No.	CHANGE DESCRIPTION
447, 485	Specification up issued to incorporate editorial and technical changes per DCRs.

TABLE OF CONTENTS

1.	<u>GENERAL</u>	<u>5</u>
1.1	Scope	5
1.2	Applicable Documents	5
1.3	Terms, Definitions, Abbreviations, Symbols and Units	5
1.4	The ESCC Component Number and Component Type Variants	5
1.4.1	The ESCC Component Number	5
1.4.2	Component Type Variants	5
1.5	Maximum Ratings	6
1.6	Handling Precautions	6
1.7	Physical Dimensions and Terminal Identification	6
1.7.1	Flat Package (FP) - 16 Pin	7
1.7.2	Dual-in-line Package (DIP) - 16 Pin	8
1.7.3	Chip Carrier Package (CCP) - 20 Terminal	9
1.7.4	Small Outline Ceramic Package (SO) - 16 Pin	11
1.7.5	Notes to Physical Dimensions and Terminal Identification	12
1.8	Functional Diagram	12
1.9	Pin Assignment	13
1.10	Truth Table and Timing Chart	13
1.11	Input Protection Network	14
2.	<u>REQUIREMENTS</u>	<u>14</u>
2.1	General	14
2.1.1	Deviations from the Generic Specification	15
2.2	Marking	15
2.3	Electrical Measurements at Room, High and Low Temperatures	15
2.3.1	Room Temperature Electrical Measurements	15
2.3.2	High and Low Temperatures Electrical Measurements	18
2.3.3	Notes to Electrical Measurement Tables	20
2.4	Parameter Drift Values	22
2.5	Intermediate and End-Point Electrical Measurements	22
2.6	High Temperature Reverse Bias Burn-in Conditions	23
2.6.1	N-Channel HTRB	23
2.6.2	P-Channel HTRB	24
2.7	Power Burn-in Conditions	24
2.8	Operating Life Conditions	24
APPENDIX 'A'		25

1. GENERAL

1.1 SCOPE

This specification details the ratings, physical and electrical characteristics and test and inspection data for the component type variants and/or the range of components specified below. It supplements the requirements of, and shall be read in conjunction with, the ESCC Generic Specification listed under Applicable Documents.

1.2 APPLICABLE DOCUMENTS

The following documents form part of this specification and shall be read in conjunction with it:

- (a) ESCC Generic Specification No. 9000
- (b) MIL-STD-883, Test Methods and Procedures for Microelectronics

1.3 TERMS, DEFINITIONS, ABBREVIATIONS, SYMBOLS AND UNITS

For the purpose of this specification, the terms, definitions, abbreviations, symbols and units specified in ESCC Basic Specification No. 21300 shall apply.

1.4 THE ESCC COMPONENT NUMBER AND COMPONENT TYPE VARIANTS

1.4.1 The ESCC Component Number

The ESCC Component Number shall be constituted as follows:

Example: 920402001

- Detail Specification Reference: 9204020
- Component Type Variant Number: 01 (as required)

1.4.2 Component Type Variants

The component type variants applicable to this specification are as follows:

Variant Number	Based on Type	Case	Terminal Material and /or Finish	Weight max g
01	4017B	FP	G2	0.7
02	4017B	FP	G4	0.7
07	4017B	CCP	2	0.6
08	4017B	DIP	G2	2.2
09	4017B	DIP	G4	2.2
10	4017B	SO	G2	0.7
11	4017B	SO	G4	0.7

The terminal material and/or finish shall be in accordance with the requirements of ESCC Basic Specification No. 23500.

1.5 MAXIMUM RATINGS

The maximum ratings shall not be exceeded at any time during use or storage.

Maximum ratings shall only be exceeded during testing to the extent specified in this specification and when stipulated in Test Methods and Procedures of the ESCC Generic Specification.

Characteristics	Symbols	Maximum Ratings	Units	Remarks
Supply Voltage	V_{DD}	-0.5 to 18	V	Note 1
Input Voltage	V_{IN}	-0.5 to $V_{DD} + 0.5$	V	Note 1 Power on
Input Current	I_{IN}	± 10	mA	-
Device Power Dissipation (Continuous)	P_D	200	mW	-
Power Dissipation per Output	P_{DSO}	100	mW	-
Operating Temperature Range	T_{op}	-55 to +125	$^{\circ}C$	T_{amb}
Storage Temperature Range	T_{stg}	-65 to +150	$^{\circ}C$	-
Soldering Temperature For FP, DIP and SO For CCP	T_{sol}	+265 +245	$^{\circ}C$	Note 2 Note 3

NOTES:

1. Device is functional for $3V \leq V_{DD} \leq 15V$.
2. Duration 10 seconds maximum at a distance of not less than 1.5mm from the device body and the same terminal shall not be resoldered until 3 minutes have elapsed.
3. Duration 5 seconds maximum and the same terminal shall not be resoldered until 3 minutes have elapsed.

1.6 HANDLING PRECAUTIONS

These devices are susceptible to damage by electrostatic discharge. Therefore, suitable precautions shall be employed for protection during all phases of manufacture, testing, packaging, shipment and any handling.

These components are categorised as Class 1 per ESCC Basic Specification No. 23800 with a minimum Critical Path Failure Voltage of 400 Volts.

1.7 PHYSICAL DIMENSIONS AND TERMINAL IDENTIFICATION

Consolidated Notes are given following the case drawings and dimensions.

1.7.1 Flat Package (FP) - 16 Pin

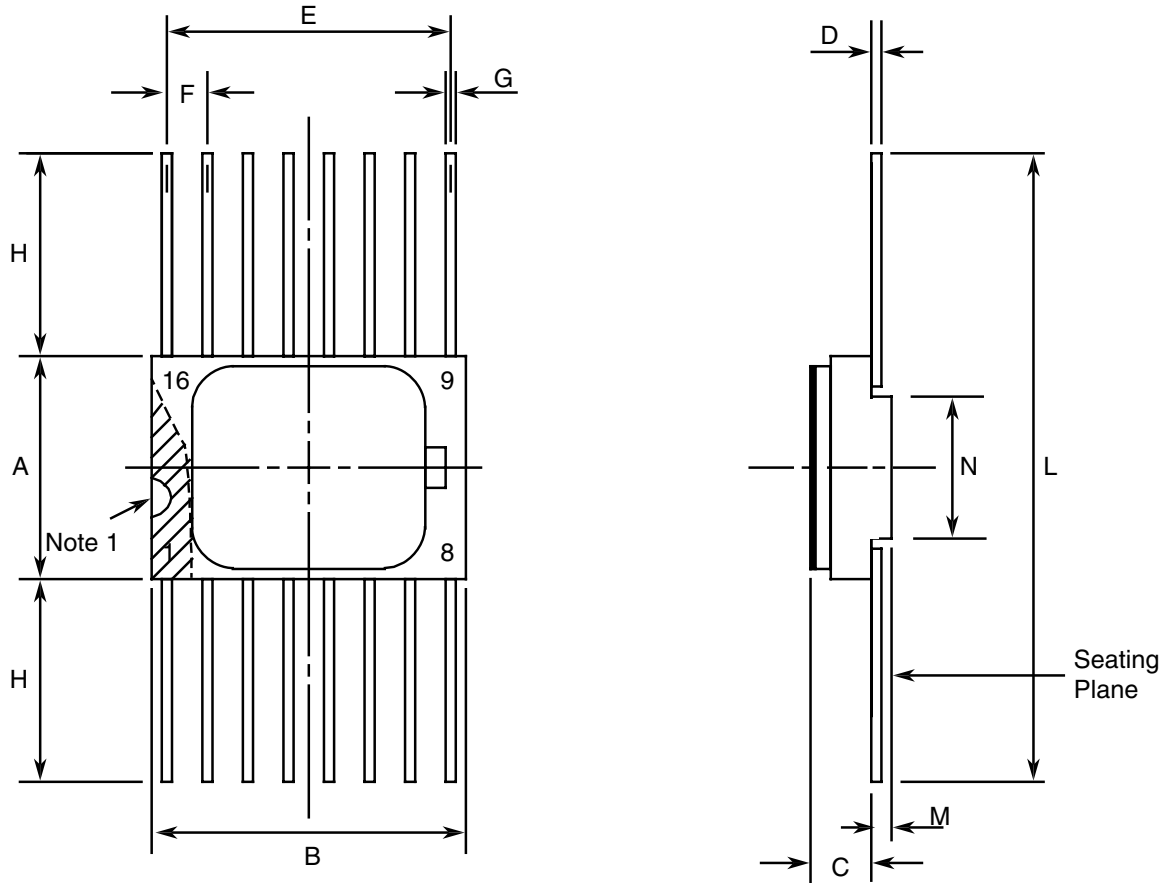

Symbols	Dimensions mm		Notes
	Min	Max	
A	6.75	7.06	
B	9.76	10.14	
C	1.49	1.95	
D	0.1	0.15	5
E	8.76	9.01	
F	1.27 BSC		3, 6
G	0.38	0.48	5
H	6	-	5
L	18.75	22	
M	0.33	0.43	
N	4.32 TYPICAL		

1.7.2 Dual-in-line Package (DIP) - 16 Pin

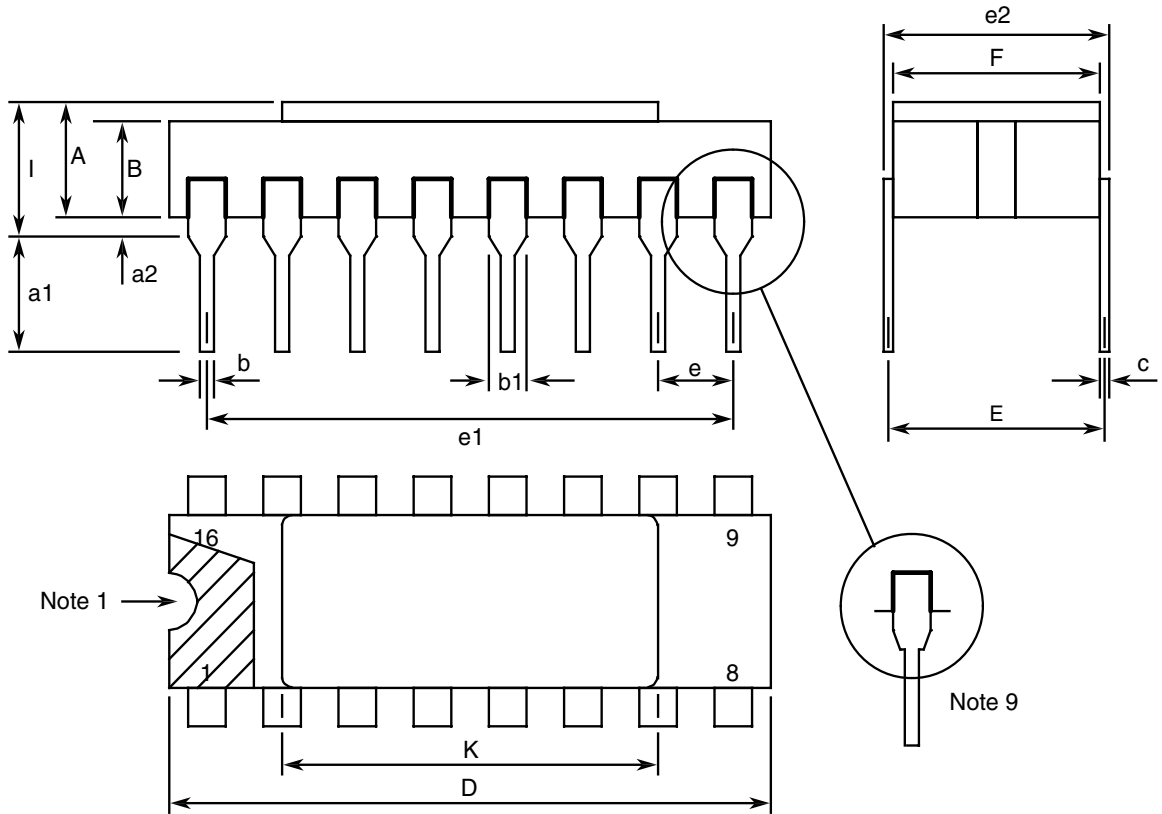

Symbols	Dimensions mm		Notes
	Min	Max	
A	2.1	2.71	
a1	3	3.7	
a2	0.63	1.14	2
B	1.82	2.39	
b	0.4	0.5	5
b1	1.14	1.5	5
c	0.2	0.3	5
D	20.06	20.58	
E	7.36	7.87	
e	2.54 BSC		4, 6
e1	17.65	17.9	
e2	7.62	8.12	
F	7.29	7.7	
l	-	3.83	

Symbols	Dimensions mm		Notes
	Min	Max	
K	10.9	12.1	

1.7.3 Chip Carrier Package (CCP) - 20 Terminal

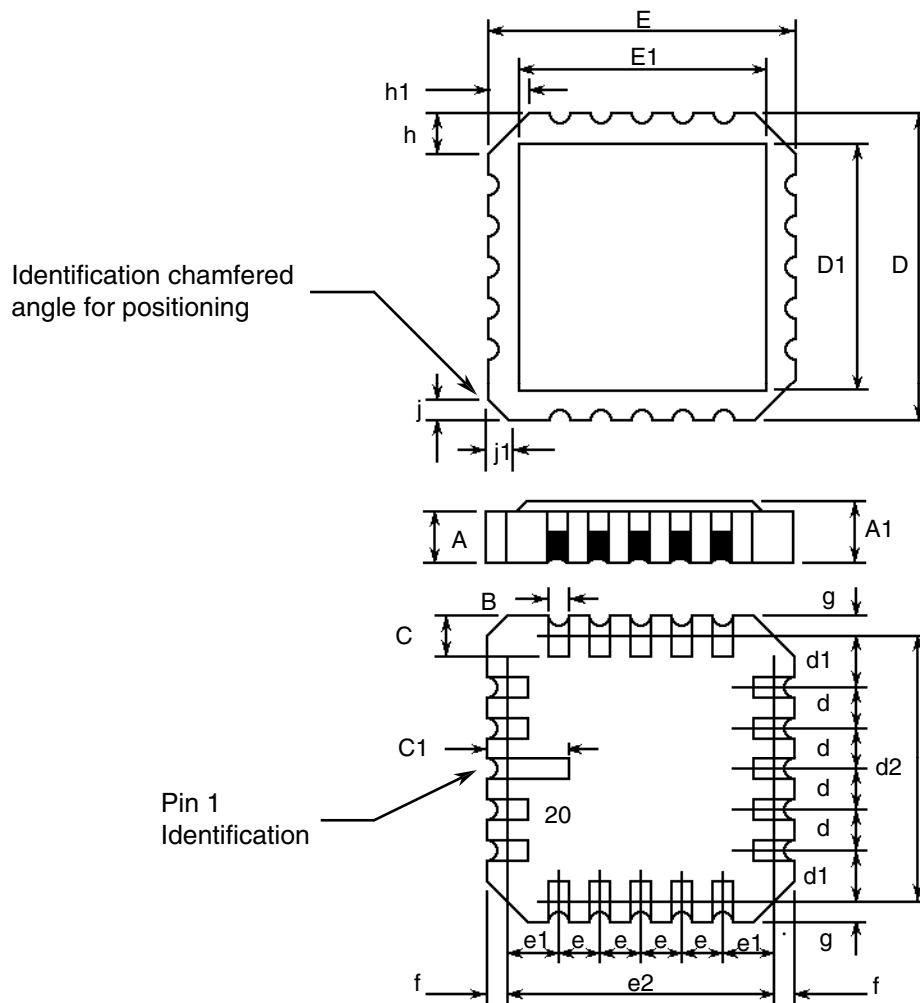

Symbols	Dimensions mm		Notes
	Min	Max	
A	1.14	1.95	
A1	1.63	2.36	
B	0.55	0.72	5
C	1.06	1.47	5
C1	1.91	2.41	

Symbols	Dimensions mm		Notes
	Min	Max	
D	8.67	9.09	
D1	7.21	7.52	
d, d1	1.27 BSC		3
d2	7.62 BSC		
E	8.67	9.09	
E1	7.21	7.52	
e, e1	1.27 BSC		3
e2	7.62 BSC		
f, g	-	0.76	
h, h1	1.01 TYPICAL		8
j, j1	0.51 TYPICAL		7

1.7.4 Small Outline Ceramic Package (SO) - 16 Pin

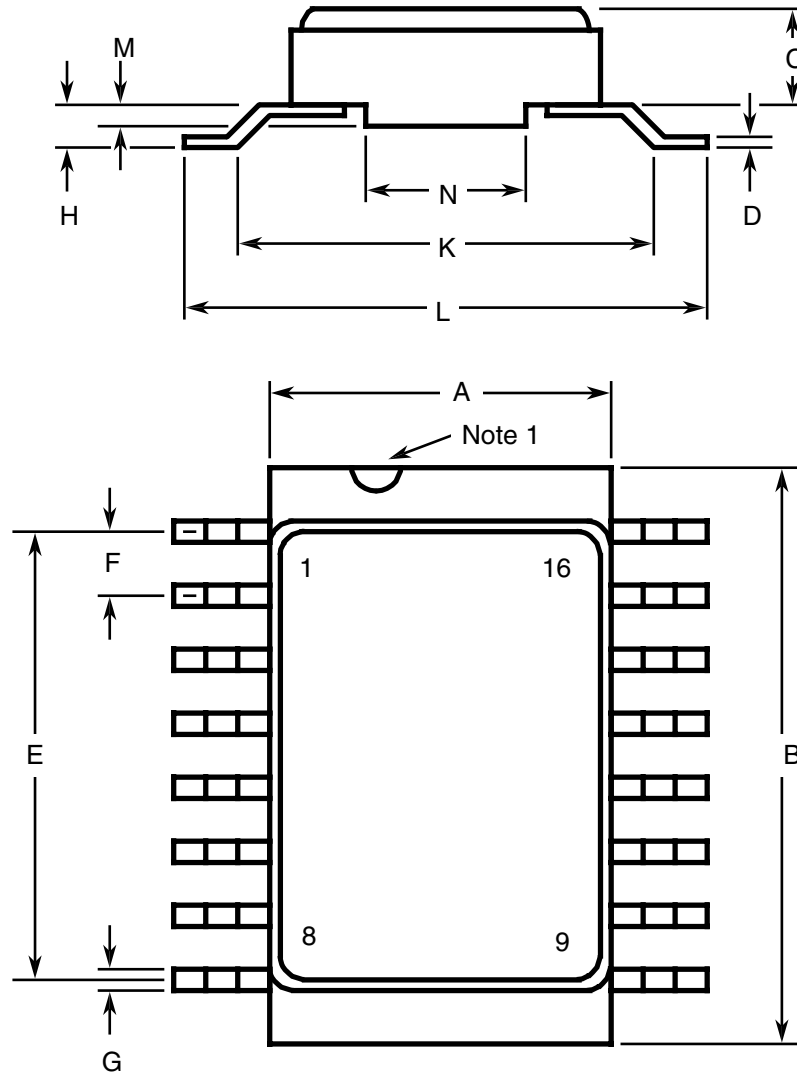

Symbols	Dimensions mm		Notes
	Min	Max	
A	6.75	7.06	
B	9.76	10.14	
C	1.49	1.95	
D	0.1	0.15	5
E	8.76	9.01	
F	1.27 BSC		3, 6
G	0.38	0.48	5
H	0.6	0.9	5

Symbols	Dimensions mm		Notes
	Min	Max	
K	9 TYPICAL		
L	10	10.65	
M	0.33	0.43	
N	4.31 TYPICAL		

1.7.5 Notes to Physical Dimensions and Terminal Identification

1. Index area; a notch or a dot shall be located adjacent to Pin 1 and shall be within the shaded area shown. For chip carrier packages, the index shall be as shown.
2. The dimension shall be measured from the seating plane to the base plane.
3. The true position pin spacing is 1.27mm between centrelines. Each pin centreline shall be located within $\pm 0.13\text{mm}$ of its true longitudinal position relative to Pin 1 and the highest pin number.
4. The true position pin spacing is 2.54mm between centrelines. Each pin centreline shall be located within $\pm 0.25\text{mm}$ of its true longitudinal position relative to Pin 1 and the highest pin number.
5. All terminals.
6. 14 spaces.
7. Index corner only - 2 dimensions.
8. 3 non-index corners - 6 dimensions.
9. For all pins, either pin shape may be supplied.

1.8 FUNCTIONAL DIAGRAM

Pin numbers relate to FP, DIP and SO packages only

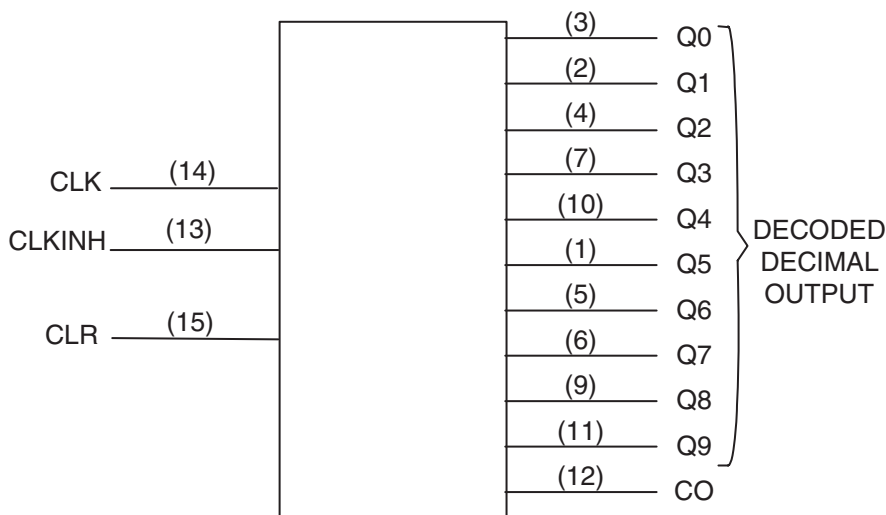

1.9 PIN ASSIGNMENT

Pin	Function		Pin	Function	
	FP, DIP and SO	CCP		FP, DIP and SO	CCP
1	Q5 Output	Q5 Output	11	Q9 Output	Q8 Output
2	Q1 Output	Q1 Output	12	CO Output (Carry Out)	Q4 Output
3	Q0 Output	-	13	CLKINH Input (Clock Inhibit)	-
4	Q2 Output	Q0 Output	14	CLK Input (Clock)	Q9 Output
5	Q6 Output	Q2 Output	15	CLR Input (Clear)	CO Output (Carry Out)
6	Q7 Output	Q6 Output	16	V _{DD}	CLKINH Input (Clock Inhibit)
7	Q3 Output	Q7 Output	17	-	CLK Input (Clock)
8	V _{SS}	-	18	-	-
9	Q8 Output	Q3 Output	19	-	CLR Input (Clear)
10	Q4 Output	V _{SS}	20	-	V _{DD}

1.10 TRUTH TABLE AND TIMING CHART

1. Logic Level Definitions: L = Low Level, H = High Level, X = Irrelevant.
2. ↑ = Transition, Low to High; ↓ = Transition, High to Low.

INPUTS			OUTPUTS
CLR	CLK	CLKINH	
H	X	X	CLEAR (Q0 = H ; Q1 to Q9 = L)
L	↑	L	COUNTER ADVANCES
L	H	↓	COUNTER ADVANCES
L	L	X	NO CHANGE
L	X	H	NO CHANGE
L	H	↑	NO CHANGE
L	↓	L	NO CHANGE

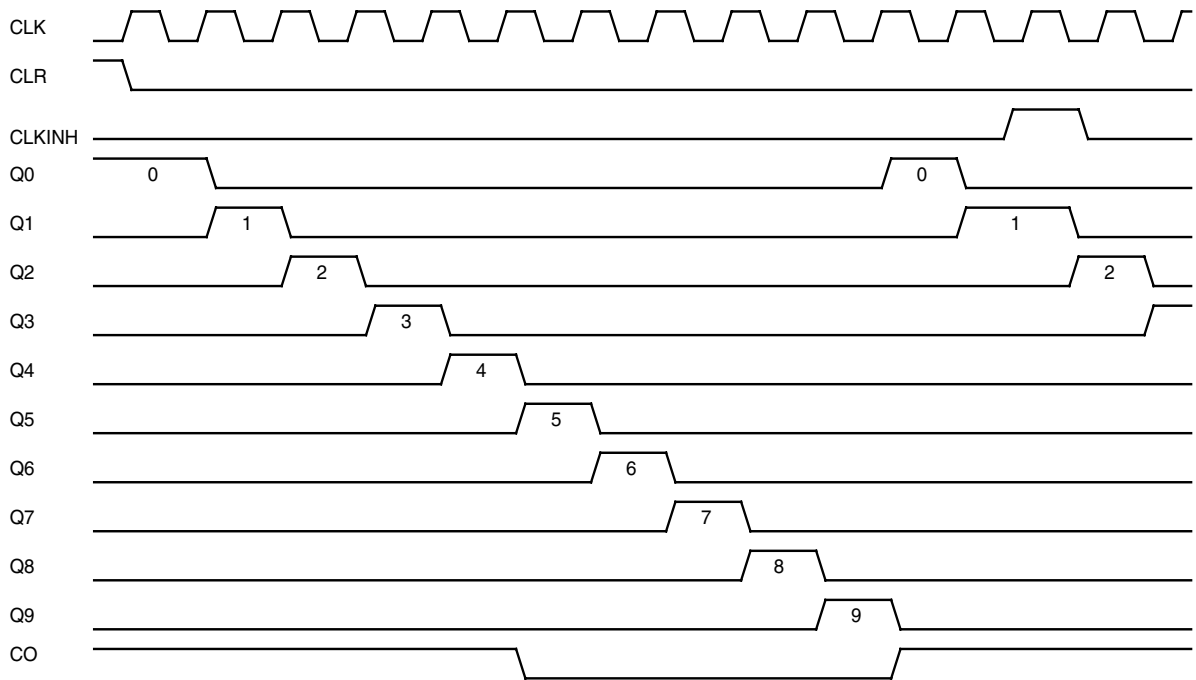

1.11 INPUT PROTECTION NETWORK

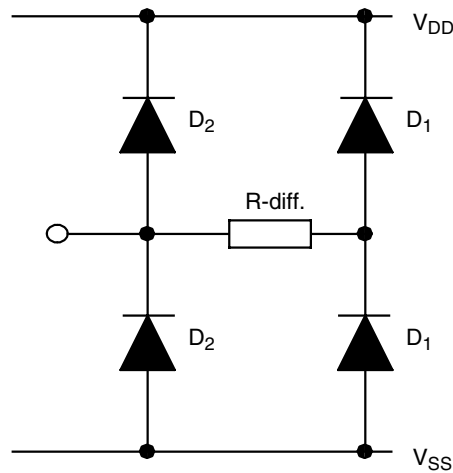

2. REQUIREMENTS

2.1 GENERAL

The complete requirements for procurement of the components specified herein are as stated in this specification and the ESCC Generic Specification. Permitted deviations from the Generic Specification, applicable to this specification only, are listed below.

Permitted deviations from the Generic Specification and this Detail Specification, formally agreed with

specific Manufacturers on the basis that the alternative requirements are equivalent to the ESCC requirement and do not affect the component's reliability, are listed in the appendices attached to this specification.

2.1.1 Deviations from the Generic Specification

None.

2.2 MARKING

The marking shall be in accordance with the requirements of ESCC Basic Specification No. 21700 and as follows.

The information to be marked on the component shall be:

- (a) Terminal identification.
- (b) The ESCC qualified components symbol (for ESCC qualified components only).
- (c) The ESCC Component Number.
- (d) Traceability information.

2.3 ELECTRICAL MEASUREMENTS AT ROOM, HIGH AND LOW TEMPERATURES

Electrical measurements shall be performed at room, high and low temperatures. Consolidated Notes are given after the tables.

2.3.1 Room Temperature Electrical Measurements

The measurements shall be performed at $T_{amb}=+22 \pm 3^{\circ}C$.

Characteristics	Symbols	MIL-STD-883 Test Method	Test Conditions Note 1	Limits		Units
				Min	Max	
Functional Test 1	-	3014	Verify Truth Table without Load $V_{IL}=0V, V_{IH}=3V$ $V_{DD}=3V, V_{SS}=0V$ Note 2	-	-	-
Functional Test 2	-	3014	Verify Truth Table without Load $V_{IL}=0V, V_{IH}=15V$ $V_{DD}=15V, V_{SS}=0V$ Note 2	-	-	-
Quiescent Current	I_{DD}	3005	$V_{IL}=0V, V_{IH}=15V$ $V_{DD}=15V, V_{SS}=0V$ Note 3	-	1	μA
Low Level Input Current	I_{IL}	3009	V_{IN} (Under Test)=0V $V_{DD}=15V, V_{SS}=0V$	-	-50	nA
High Level Input Current	I_{IH}	3010	V_{IN} (Under Test)=15V $V_{DD}=15V, V_{SS}=0V$	-	50	nA

Characteristics	Symbols	MIL-STD-883 Test Method	Test Conditions Note 1	Limits		Units
				Min	Max	
Low Level Output Voltage 1	V_{OL1}	3007	$V_{IL}=0V, V_{IH}=15V,$ $I_{OL}=0A$ $V_{DD}=15V, V_{SS}=0V$	-	50	mV
Low Level Output Voltage 2 (Noise Immunity)	V_{OL2}	3007	$V_{IL}=1.5V, V_{IH}=3.5V,$ $I_{OL}=0A$ $V_{DD}=5V, V_{SS}=0V$	-	500	mV
Low Level Output Voltage 3 (Noise Immunity)	V_{OL3}	3007	$V_{IL}=4V, V_{IH}=11V,$ $I_{OL}=0A$ $V_{DD}=15V, V_{SS}=0V$	-	1.5	V
High Level Output Voltage 1	V_{OH1}	3006	$V_{IL}=0V, V_{IH}=15V,$ $I_{OH}=0A$ $V_{DD}=15V, V_{SS}=0V$	14.95	-	V
High Level Output Voltage 2 (Noise Immunity)	V_{OH2}	3006	$V_{IL}=1.5V, V_{IH}=3.5V,$ $I_{OH}=0A$ $V_{DD}=5V, V_{SS}=0V$	4.5	-	V
High Level Output Voltage 3 (Noise Immunity)	V_{OH3}	3006	$V_{IL}=4V, V_{IH}=11V,$ $I_{OH}=0A$ $V_{DD}=15V, V_{SS}=0V$	13.5	-	V
Low Level Output Current 1	I_{OL1}	-	$V_{IL}=0V, V_{IH}=5V,$ $V_{OL}=0.4V$ $V_{DD}=5V, V_{SS}=0V$ Note 4	510	-	μA
Low Level Output Current 2	I_{OL2}	-	$V_{IL}=0V, V_{IH}=15V,$ $V_{OL}=1.5V$ $V_{DD}=15V, V_{SS}=0V$ Note 4	3.4	-	mA
High Level Output Current 1	I_{OH1}	-	$V_{IL}=0V, V_{IH}=5V,$ $V_{OH}=4.6V$ $V_{DD}=5V, V_{SS}=0V$ Note 4	-510	-	μA
High Level Output Current 2	I_{OH2}	-	$V_{IL}=0V, V_{IH}=15V,$ $V_{OH}=13.5V$ $V_{DD}=15V, V_{SS}=0V$ Note 4	-3.4	-	mA
Threshold Voltage N-Channel	V_{THN}	-	CLR Input at Ground All Other Inputs: $V_{IN}=5V$ $V_{DD}=5V, I_{SS}=-10\mu A$	-0.7	-3	V
Threshold Voltage P-Channel	V_{THP}	-	CLR Input at Ground All Other Inputs: $V_{IN}=-5V$ $V_{SS}=-5V, I_{DD}=10\mu A$	0.7	3	V
Input Clamp Voltage 1, to V_{SS}	V_{IC1}	-	I_{IN} (Under Test)= -100 μA $V_{DD}=\text{Open}, V_{SS}=0V$ All Other Pins Open	-	-2	V

Characteristics	Symbols	MIL-STD-883 Test Method	Test Conditions Note 1	Limits		Units
				Min	Max	
Input Clamp Voltage 2, to V_{DD}	V_{IC2}	-	V_{IN} (Under Test)=6V R=30k Ω , V_{SS} =Open All Other Pins Open Note 5	3	-	V
Input Capacitance	C_{IN}	3012	V_{IN} (Not Under Test)=0V $V_{DD}=V_{SS}=0V$ f = 100 kHz to 1 MHz Note 6	-	7.5	pF
Propagation Delay Low to High, CLK to Q1	t_{PLH1}	3003	V_{IN} (Under Test)=Pulse Generator V_{IN} (Remaining Inputs)=Truth Table $V_{IL}=0V$, $V_{IH}=5V$, $V_{DD}=5V$, $V_{SS}=0V$ Note 7	-	750	ns
Propagation Delay Low to High, CLK to CO	t_{PLH2}	3003	V_{IN} (Under Test)=Pulse Generator V_{IN} (Remaining Inputs)=Truth Table $V_{IL}=0V$, $V_{IH}=5V$, $V_{DD}=5V$, $V_{SS}=0V$ Note 7	-	600	ns
Propagation Delay Low to High, CLR to Q0	t_{PLH3}	3003	V_{IN} (Under Test)=Pulse Generator CLR Connected to V_{DD} V_{IN} (Remaining Inputs)=Truth Table $V_{IL}=0V$, $V_{IH}=5V$, $V_{DD}=5V$, $V_{SS}=0V$ Note 7	-	750	ns
Propagation Delay Low to High, CLR to CO	t_{PLH4}	3003	V_{IN} (Under Test)=Pulse Generator CLR Connected to V_{DD} V_{IN} (Remaining Inputs)=Truth Table $V_{IL}=0V$, $V_{IH}=5V$, $V_{DD}=5V$, $V_{SS}=0V$ Note 7	-	600	ns
Propagation Delay High to Low, CLK to Q1	t_{PHL1}	3003	V_{IN} (Under Test)=Pulse Generator V_{IN} (Remaining Inputs)=Truth Table $V_{IL}=0V$, $V_{IH}=5V$, $V_{DD}=5V$, $V_{SS}=0V$ Note 7	-	750	ns

Characteristics	Symbols	MIL-STD-883 Test Method	Test Conditions Note 1	Limits		Units
				Min	Max	
Propagation Delay High to Low, CLK to CO	t_{PHL2}	3003	V_{IN} (Under Test)=Pulse Generator V_{IN} (Remaining Inputs)=Truth Table $V_{IL}=0V, V_{IH}=5V, V_{DD}=5V, V_{SS}=0V$ Note 7	-	600	ns
Propagation Delay High to Low, CLR to Q2	t_{PHL3}	3003	V_{IN} (Under Test)=Pulse Generator V_{IN} (Remaining Inputs)=Truth Table $V_{IL}=0V, V_{IH}=5V, V_{DD}=5V, V_{SS}=0V$ Note 7	-	750	ns
Transition Time Low to High, Q1	t_{TLH}	3004	V_{IN} (Under Test)=Pulse Generator V_{IN} (Remaining Inputs)=Truth Table $V_{IL}=0V, V_{IH}=5V, V_{DD}=5V, V_{SS}=0V$ Note 7	-	150	ns
Transition Time High to Low, Q1	t_{THL}	3004	V_{IN} (Under Test)=Pulse Generator V_{IN} (Remaining Inputs)=Truth Table $V_{IL}=0V, V_{IH}=5V, V_{DD}=5V, V_{SS}=0V$ Note 7	-	150	ns
Maximum Clock Frequency	f_{CLK}	-	V_{IN} (CLK)=Pulse Generator V_{IN} (Remaining Inputs)= V_{SS} $V_{IL}=0V, V_{IH}=5V, V_{DD}=5V, V_{SS}=0V$ Notes 8, 9	2.5	-	MHz

2.3.2 High and Low Temperatures Electrical Measurements

The measurements shall be performed at $T_{amb}=+125 (+0 -5) ^\circ C$ and $T_{amb}=- 55(+5-0)^\circ C$.

Characteristics	Symbols	MIL-STD-883 Test Method	Test Conditions Note 1	Limits		Units
				Min	Max	
Functional Test 1	-	3014	Verify Truth Table without Load $V_{IL}=0V, V_{IH}=3V, V_{DD}=3V, V_{SS}=0V$ Note 2	-	-	-

Characteristics	Symbols	MIL-STD-883 Test Method	Test Conditions Note 1	Limits		Units
				Min	Max	
Functional Test 2	-	3014	Verify Truth Table without Load $V_{IL}=0V, V_{IH}=15V$ $V_{DD}=15V, V_{SS}=0V$ Note 2	-	-	-
Quiescent Current	I_{DD}	3005	$V_{IL}=0V, V_{IH}=15V$ $V_{DD}=15V, V_{SS}=0V$ Note 3 $T_{amb}=+125^{\circ}C$ $T_{amb}=-55^{\circ}C$	- -	30 1	μA
Low Level Input Current	I_{IL}	3009	V_{IN} (Under Test)= $0V$ $V_{DD}=15V, V_{SS}=0V$ $T_{amb}=+125^{\circ}C$ $T_{amb}=-55^{\circ}C$	- -	-100 -50	nA
High Level Input Current	I_{IH}	3010	V_{IN} (Under Test)= $15V$ $V_{DD}=15V, V_{SS}=0V$ $T_{amb}=+125^{\circ}C$ $T_{amb}=-55^{\circ}C$	- -	100 50	nA
Low Level Output Voltage 1	V_{OL1}	3007	$V_{IL}=0V, V_{IH}=15V,$ $I_{OL}=0A$ $V_{DD}=15V, V_{SS}=0V$	-	50	mV
Low Level Output Voltage 2 (Noise Immunity)	V_{OL2}	3007	$V_{IL}=1.5V, V_{IH}=3.5V,$ $I_{OL}=0A$ $V_{DD}=5V, V_{SS}=0V$	-	500	mV
Low Level Output Voltage 3 (Noise Immunity)	V_{OL3}	3007	$V_{IL}=4V, V_{IH}=11V,$ $I_{OL}=0A$ $V_{DD}=15V, V_{SS}=0V$	-	1.5	V
High Level Output Voltage 1	V_{OH1}	3006	$V_{IL}=0V, V_{IH}=15V,$ $I_{OH}=0A$ $V_{DD}=15V, V_{SS}=0V$	14.95	-	V
High Level Output Voltage 2 (Noise Immunity)	V_{OH2}	3006	$V_{IL}=1.5V, V_{IH}=3.5V,$ $I_{OH}=0A$ $V_{DD}=5V, V_{SS}=0V$	4.5	-	V
High Level Output Voltage 3 (Noise Immunity)	V_{OH3}	3006	$V_{IL}=4V, V_{IH}=11V,$ $I_{OH}=0A$ $V_{DD}=15V, V_{SS}=0V$	13.5	-	V
Low Level Output Current 1	I_{OL1}	-	$V_{IL}=0V, V_{IH}=5V,$ $V_{OL}=0.4V$ $V_{DD}=5V, V_{SS}=0V$ Note 4 $T_{amb}=+125^{\circ}C$ $T_{amb}=-55^{\circ}C$	360 640	- -	μA

Characteristics	Symbols	MIL-STD-883 Test Method	Test Conditions Note 1	Limits		Units
				Min	Max	
Low Level Output Current 2	I_{OL2}	-	$V_{IL}=0V, V_{IH}=15V,$ $V_{OL}=1.5V$ $V_{DD}=15V, V_{SS}=0V$ Note 4 $T_{amb}=+125^{\circ}C$ $T_{amb}=-55^{\circ}C$	2.4 4.2	- -	mA
High Level Output Current 1	I_{OH1}	-	$V_{IL}=0V, V_{IH}=5V,$ $V_{OH}=4.6V$ $V_{DD}=5V, V_{SS}=0V$ Note 4 $T_{amb}=+125^{\circ}C$ $T_{amb}=-55^{\circ}C$	-360 -640	- -	μA
High Level Output Current 2	I_{OH2}	-	$V_{IL}=0V, V_{IH}=15V,$ $V_{OH}=13.5V$ $V_{DD}=15V, V_{SS}=0V$ Note 4 $T_{amb}=+125^{\circ}C$ $T_{amb}=-55^{\circ}C$	-2.4 -4.2	- -	mA
Threshold Voltage N-Channel	V_{THN}	-	CLR Input at Ground All Other Inputs: $V_{IN}=5V$ $V_{DD}=5V, I_{SS}=-10\mu A$ $T_{amb}=+125^{\circ}C$ $T_{amb}=-55^{\circ}C$	-0.3 -0.7	-3.5 -3.5	V
Threshold Voltage P-Channel	V_{THP}	-	CLR Input at Ground All Other Inputs: $V_{IN}=-5V$ $V_{SS}=-5V, I_{DD}=10\mu A$ $T_{amb}=+125^{\circ}C$ $T_{amb}=-55^{\circ}C$	0.3 0.7	3.5 3.5	V

2.3.3

Notes to Electrical Measurement Tables

1. Unless otherwise specified all inputs and outputs shall be tested for each characteristic, inputs not under test shall be $V_{IN} = V_{SS}$ or V_{DD} and outputs not under test shall be open.
2. Functional tests shall be performed to verify Truth Table with $V_{OH} \geq V_{DD} - 0.5V$, $V_{OL} \leq 0.5V$. The maximum time to output comparator strobe = 300 μs .
3. Quiescent Current shall be tested using the following input conditions where 1 = V_{IH} and 0 = V_{IL} :

I _{DD} Test	Input Pattern No.	Input Conditions		
		CLKINH	CLK	CLR
(a)	1	0	0	1
(b)	2	1	1	1
	3	1	1	0
(c)	4	0	1	0
	5	1	1	0
(d)	6	0	1	0
	7	1	1	0
	8	0	1	0
(e)	9	1	1	0
	10	0	1	0
(f)	11	1	1	0
	12	0	1	0
(g)	13	0	0	0
(h)	14	0	1	0
	15	0	0	0
(i)	16	0	1	0
	17	0	0	0
(j)	18	0	1	0
	19	0	0	0
(k)	20	0	1	0

4. Interchange of forcing and measuring parameters is permitted.
5. Input Clamp Voltage 2 to V_{DD}, V_{IC2}, shall be tested on each input as follows:-

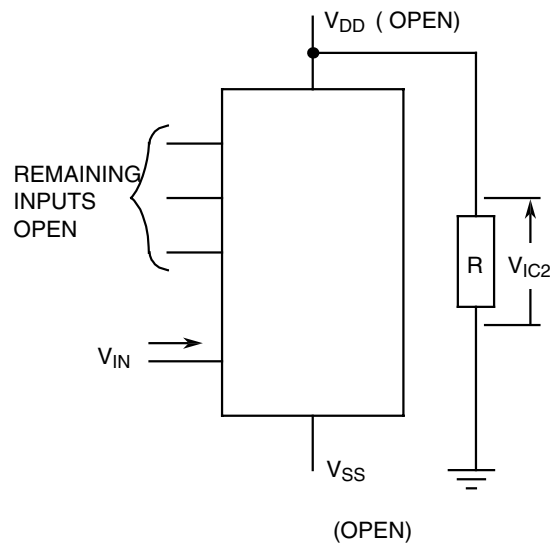

6. Guaranteed but not tested.
7. Read and record measurements shall be performed on a sample of 32 components with 0 failures permitted.
The pulse generator shall have the following characteristics:
 $V_{GEN} = 0$ to V_{DD} ; $f_{GEN} = 500\text{kHz}$; t_r and $t_f \leq 15$ ns (10% to 90%); duty cycle = 50%; $Z_{out} = 50\Omega$. Output load capacitance $C_L = 50\text{pF} \pm 5\%$ including scope probe, wiring and stray capacitance without component in the test fixture. Output load resistance $R_L = 200\text{k}\Omega \pm 5\%$.
Propagation delay shall be measured referenced to the 50% input and output voltages.
Transition time shall be measured referenced to the 10% and 90% output voltage.
8. Read and record measurements shall be performed on a sample of 32 components with 0 failures permitted.
9. A pulse, having the following conditions, shall be applied to the CLK input: $V_P=0\text{V}$ to V_{DD} . Maximum clock frequency of f_{CLK} requirement is considered met if proper output state changes occur with the pulse repetition rate set to that given in the Limits column.

2.4 PARAMETER DRIFT VALUES

Unless otherwise specified, the measurements shall be performed at $T_{amb}=+22 \pm 3^\circ\text{C}$.

The test methods and test conditions shall be as per the corresponding test defined in Room Temperature Electrical Measurements.

The drift values (Δ) shall not be exceeded for each characteristic specified. The corresponding absolute limit values for each characteristic shall not be exceeded.

Characteristics	Symbols	Limits			Units
		Drift Value Δ	Absolute		
			Min	Max	
Quiescent Current	I_{DD}	± 0.15	-	1	μA
Low Level Output Current 1	I_{OL1}	$\pm 15\%$ (2)	510	-	μA
High Level Output Current 1	I_{OH1}	$\pm 15\%$ (2)	-510	-	μA
Threshold Voltage N-Channel	V_{THN}	± 0.3	-0.7	-3	V
Threshold Voltage P-Channel	V_{THP}	± 0.3	0.7	3	V

NOTES:

1. Unless otherwise specified all inputs and outputs shall be tested for each characteristic.
2. Percentage of limit value if voltage is the measuring parameter.

2.5 INTERMEDIATE AND END-POINT ELECTRICAL MEASUREMENTS

Unless otherwise specified, the measurements shall be performed at $T_{amb}=+22 \pm 3^\circ\text{C}$.

The test methods and test conditions shall be as per the corresponding test defined in Room Temperature Electrical Measurements.

The drift values (Δ) shall not be exceeded for each characteristic where specified. The corresponding

absolute limit values for each characteristic shall not be exceeded.

Characteristics	Symbols	Limits			Units
		Drift Value Δ	Absolute		
			Min	Max	
Functional Test 1	-	-	-	-	-
Quiescent Current	I_{DD}	± 0.15	-	1	μA
Low Level Input Current	I_{IL}	-	-	-50	nA
High Level Input Current	I_{IH}	-	-	50	nA
Low Level Output Voltage 1	V_{OL1}	-	-	50	mV
Low Level Output Voltage 2 (Noise Immunity)	V_{OL2}	-	-	500	mV
High Level Output Voltage 1	V_{OH1}	-	14.95	-	V
High Level Output Voltage 2 (Noise Immunity)	V_{OH2}	-	4.5	-	V
Low Level Output Current 1	I_{OL1}	$\pm 15\%$ (3)	510	-	μA
Low Level Output Current 2	I_{OL2}	$\pm 15\%$ (3)	3.4	-	mA
High Level Output Current 1	I_{OH1}	$\pm 15\%$ (3)	-510	-	μA
High Level Output Current 2	I_{OH2}	$\pm 15\%$ (3)	-3.4	-	mA
Threshold Voltage N-Channel	V_{THN}	± 0.3	-0.7	-3	V
Threshold Voltage P-Channel	V_{THP}	± 0.3	0.7	3	V

NOTES:

1. Unless otherwise specified all inputs and outputs shall be tested for each characteristic.
2. The drift values (Δ) are applicable to the Operating Life test only.
3. Percentage of limit value if voltage is the measuring parameter.

2.6 HIGH TEMPERATURE REVERSE BIAS BURN-IN CONDITIONS

2.6.1 N-Channel HTRB

Characteristics	Symbols	Test Conditions	Units
Ambient Temperature	T_{amb}	+125 (+0 -5)	$^{\circ}C$
Outputs Q, CO	V_{OUT}	Open	V
Input CLR	V_{IN}	V_{DD}	V
Inputs CLK, CLKINH	V_{IN}	V_{SS}	V
Positive Supply Voltage	V_{DD}	15 (+0 -0.5)	V
Negative Supply Voltage	V_{SS}	0	V

Characteristics	Symbols	Test Conditions	Units
Duration	t	72	Hours

NOTES:

1. Input Protection Resistor = 2kΩ min to 47kΩ max.

2.6.2 P-Channel HTRB

Characteristics	Symbols	Test Conditions	Units
Ambient Temperature	T _{amb}	+125 (+0 -5)	°C
Outputs Q, CO	V _{OUT}	Open	V
Input CLR	V _{IN}	V _{SS}	V
Inputs CLK, CLKINH	V _{IN}	V _{DD}	V
Positive Supply Voltage	V _{DD}	15 (+0 -0.5)	V
Negative Supply Voltage	V _{SS}	0	V
Duration	t	72	Hours

NOTES:

1. Input Protection Resistor = 2kΩ min to 47kΩ max.

2.7 POWER BURN-IN CONDITIONS

Characteristics	Symbols	Test Conditions	Units
Ambient Temperature	T _{amb}	+125 (+0 -5)	°C
Outputs Q, CO	V _{OUT}	V _{DD} /2	V
Inputs CLR, CLKINH	V _{IN}	V _{SS}	V
Input CLK	V _{IN}	V _{GEN}	V
Pulse Voltage	V _{GEN}	0V to V _{DD}	V
Pulse Frequency Square Wave	f _{GEN}	50k ≤ f ≤ 1M 50% Duty Cycle	Hz
Positive Supply Voltage	V _{DD}	15 (+0 -0.5)	V
Negative Supply Voltage	V _{SS}	0	V

NOTES:

1. Input Protection Resistor = Output Load = 2kΩ min to 47kΩ max.

2.8 OPERATING LIFE CONDITIONS

The conditions shall be as specified for Power Burn-in.

APPENDIX 'A'

AGREED DEVIATIONS FOR STMICROELECTRONICS (F)

ITEMS AFFECTED	DESCRIPTION OF DEVIATIONS
<p>Deviations from Screening Tests - Chart F3</p>	<p>External Visual Inspection: The criteria applicable to chip-outs are those described in MIL-STD-883, Test Method 2009, Paras 3.3.6(b) and 3.3.7(a).</p> <p>High Temperature Reverse Bias Burn-in: The temperature limits of MIL-STD-883, Para. 4.5.8(c) may be used.</p> <p>Power Burn-in test is performed using STMicroelectronics Specification Ref: 0019255.</p> <p>Solderability is not applicable unless specifically stipulated in the Purchase Order.</p>
<p>Deviations from Qualification and Periodic Tests - Chart F4</p>	<p>External Visual Inspection: The criteria applicable to chip-outs are those described in MIL-STD-883, Test Method 2009, Paras 3.3.6(b) and 3.3.7(a).</p> <p>Operating Life: The temperature limits of MIL-STD-883, Para. 4.5.8(c) may be used.</p>
<p>Deviations from High and Low Temperatures Electrical Measurements</p>	<p>High and Low Temperatures Electrical Measurements may be considered guaranteed but not tested if successful pilot lot testing has been performed on the wafer lot which includes High and Low Temperatures Electrical Measurements per the Detail Specification.</p> <p>A summary of the pilot lot testing shall be provided if required by the Purchase Order.</p>
<p>Deviations from Room Temperature Electrical Measurements</p>	<p>All AC characteristics (Capacitance and Timings) may be considered guaranteed but not tested if successful pilot lot testing has been performed on the wafer lot which includes AC characteristic measurements per the Detail Specification.</p> <p>A summary of the pilot lot testing shall be provided if required by the Purchase Order.</p>