



Pages 1 to 19

**ATTENUATOR,
RF, COAXIAL, TYPE SMA 2.9, DC - 31.5GHZ**

ESCC Detail Specification No. 3403/008

Issue 3	September 2011
---------	----------------



Document Custodian: European Space Agency - see <https://escies.org>

LEGAL DISCLAIMER AND COPYRIGHT

European Space Agency, Copyright © 2011. All rights reserved.

The European Space Agency disclaims any liability or responsibility, to any person or entity, with respect to any loss or damage caused, or alleged to be caused, directly or indirectly by the use and application of this ESCC publication.

This publication, without the prior permission of the European Space Agency and provided that it is not used for a commercial purpose, may be:

- copied in whole, in any medium, without alteration or modification.
- copied in part, in any medium, provided that the ESCC document identification, comprising the ESCC symbol, document number and document issue, is removed.

DOCUMENTATION CHANGE NOTICE

(Refer to <https://escies.org> for ESCC DCR content)

DCR No.	CHANGE DESCRIPTION
578, 627, 649	Specification up issued to incorporate editorial and technical changes per DCR.

TABLE OF CONTENTS

1.	<u>GENERAL</u>	5
1.1	Scope	5
1.2	Applicable Documents	5
1.3	Terms, Definitions, Abbreviations, Symbols and Units	5
1.4	The ESCC Component Number and Component Type Variants	5
1.4.1	The ESCC Component Number	5
1.4.2	Component Type Variants and Range of Components	5
1.5	Maximum Ratings	6
1.6	Physical Dimensions	7
1.6.1	Interface Dimensions	8
1.6.2	Mating Gauge Dimensions	12
1.7	Materials and Finishes	15
2.	<u>REQUIREMENTS</u>	15
2.1	General	15
2.1.1	Deviations from the Generic Specification	15
2.1.1.1	Deviations from Qualification and Periodic Tests - Chart F4	15
2.2	Marking	15
2.3	Contact Engagement and Separation Forces Test	15
2.4	Coupling Proof Torque Test	16
2.5	Mating and Unmating Forces Test	16
2.6	Electrical Measurements at Room, High and Low temperatures	16
2.6.1	Room Temperature Electrical Measurements	16
2.6.2	High and Low Temperatures Electrical Measurements	17
2.7	Parameter Drift Values	17
2.8	Intermediate and End-Point Electrical Measurements	17
2.9	Burn-in Conditions	19
2.10	Operating Life Conditions	19

1. GENERAL

1.1 SCOPE

This specification details the ratings, physical and electrical characteristics and test and inspection data for the component type variants and/or the range of components specified below. It supplements the requirements of, and shall be read in conjunction with, the ESCC Generic Specification listed under Applicable Documents.

1.2 APPLICABLE DOCUMENTS

The following documents form part of this specification and shall be read in conjunction with it:

- (a) ESCC Generic Specification No. 3403.

1.3 TERMS, DEFINITIONS, ABBREVIATIONS, SYMBOLS AND UNITS

For the purpose of this specification, the terms, definitions, abbreviations, symbols and units specified in ESCC Basic Specification No. 21300 shall apply.

1.4 THE ESCC COMPONENT NUMBER AND COMPONENT TYPE VARIANTS

1.4.1 The ESCC Component Number

The ESCC Component Number shall be constituted as follows:

Example: 340300801

- Detail Specification Reference: 3403008
- Component Type Variant Number: 01 (as required)

1.4.2 Component Type Variants and Range of Components

The component type variants and range of components applicable to this specification are as follows:

Variant Number	Nominal Attenuation (dB)	Attenuation Tolerance (dB)		Voltage Standing Wave Ratio	Weight Max (g)
		DC to 17.5GHz	17.5 to 31.5GHz	DC to 31.5GHz	
01	0	± 0.8	± 0.5	≤ 1.5	7
02	0.5	± 0.8	± 0.5	≤ 1.5	7
03	1	± 0.8	± 0.5	≤ 1.5	7
04	1.5	± 0.8	± 0.5	≤ 1.5	7
05	2	± 0.8	± 0.5	≤ 1.5	7
06	2.5	± 0.8	± 0.5	≤ 1.5	7
07	3	± 0.8	± 0.5	≤ 1.5	7
08	3.5	± 0.8	± 0.5	≤ 1.5	7
09	4	± 0.8	± 0.5	≤ 1.5	7
10	4.5	± 0.8	± 0.5	≤ 1.5	7
11	5	± 0.8	± 0.5	≤ 1.5	7
12	5.5	± 0.8	± 0.5	≤ 1.5	7
13	6	± 0.8	± 0.5	≤ 1.5	7
14	6.5	± 0.8	± 0.5	≤ 1.5	7
15	7	± 0.8	± 0.5	≤ 1.5	7
16	7.5	± 0.8	± 0.5	≤ 1.5	7
17	8	± 0.8	± 0.5	≤ 1.5	7
18	8.5	± 0.8	± 0.5	≤ 1.5	7
19	9	± 0.8	± 0.5	≤ 1.5	7
20	9.5	± 0.8	± 0.5	≤ 1.5	7
21	10	± 0.8	± 0.5	≤ 1.5	7
22 (Note 1)	0	± 0.8	± 0.5	≤ 1.5	7

NOTES:

- Variant 22 is a DC shunt attenuator that includes a high value series resistance element.

1.5

MAXIMUM RATINGS

The maximum ratings shall not be exceeded at any time during use or storage.

Maximum ratings shall only be exceeded during testing to the extent specified in this specification and when stipulated in Test Methods and Procedures of the ESCC Generic Specification.

Characteristics	Symbols	Maximum Ratings	Units	Remarks
RF Power	P _{RF}	500	mW	Note 1 T _{amb} ≤ +25°C

Characteristics	Symbols	Maximum Ratings	Units	Remarks
Peak Power	P_P	Note 2	W	duration 1 μ s 1% duty cycle $T_{amb} \leq +25^{\circ}\text{C}$
DC Power	P_{DC}	500	mW	$T_{amb} \leq +25^{\circ}\text{C}$
Impedance	Z	47.5 to 52.5	Ω	-
Frequency Range	f_{op}	DC to 40	GHz	-
RF Leakage	E	- 60	dBi	-
Operating Temperature Range	T_{op}	-55 to +125	$^{\circ}\text{C}$	T_{amb}
Storage Temperature Range	T_{stg}	-55 to +125	$^{\circ}\text{C}$	-
Coupling Nut Torque	Tq	120	N.cm	Note 3

NOTES:

- RF Power shall be derated against operating temperature as follows:
For $T_{amb} > +25^{\circ}\text{C}$, derate linearly to 125mW at $+125^{\circ}\text{C}$.
- For Variants 01 to 21 the maximum rated Peak Power shall be 50W.
For Variant 22 the maximum rated Peak Power shall be 25W.
- Coupling Proof Torque: 170N.cm. During engagement of the component with its mating counterpart the body of the component shall be restrained by means of the body flats whilst torque is applied to the coupling nuts (see Physical Dimensions).

1.6 PHYSICAL DIMENSIONS

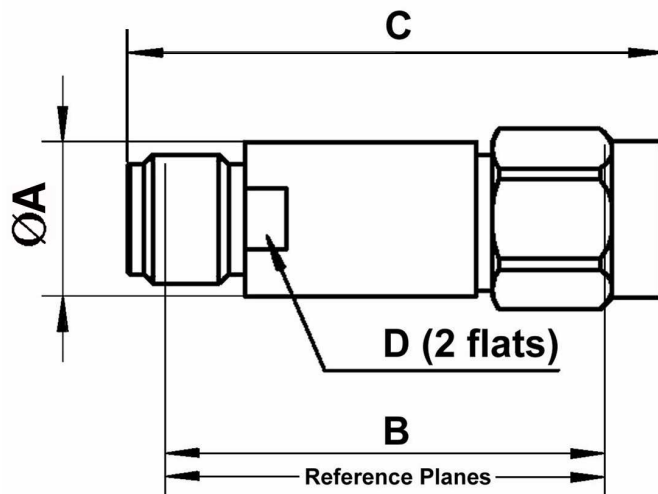

Symbols	Dimensions mm		Notes
	Min	Max	
ØA	7	8	-
B	21	22	-
C	-	26.5	-
D	6.5	7.5	1

NOTES:

1. The body flats shall be used to restrain the body during engagement whilst torque is being applied to the coupling nuts.

1.6.1 Interface Dimensions

Female Interface

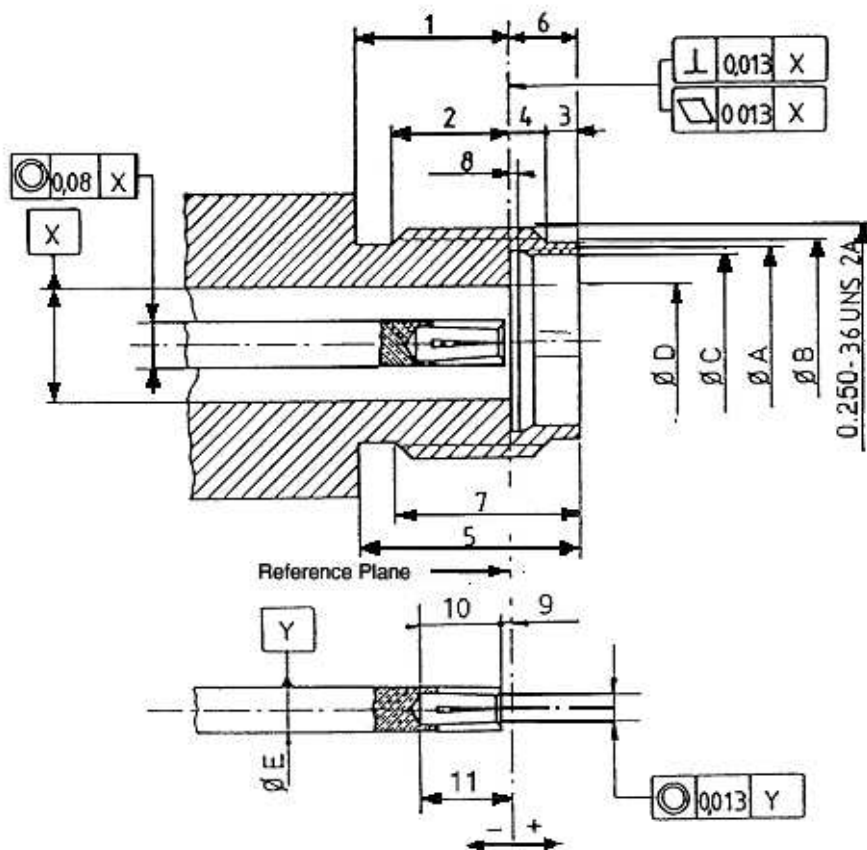

Symbols	Dimensions mm	
	Min	Max
1	3.82	4.32
2	2.87	3.27
3	0.65	0.95
4	0.93	1.33
5	5.8	6.2
6	1.88	1.98
7	4.85	5.15
8	0.3	0.5
9	0	0.08
10	2.4	2.6
11	2.4	2.68
ØA	4.8	5
ØB	5.3	5.35
ØC	4.6	4.63
ØD	2.905	2.945
ØE	1.26	1.28

Male Interface

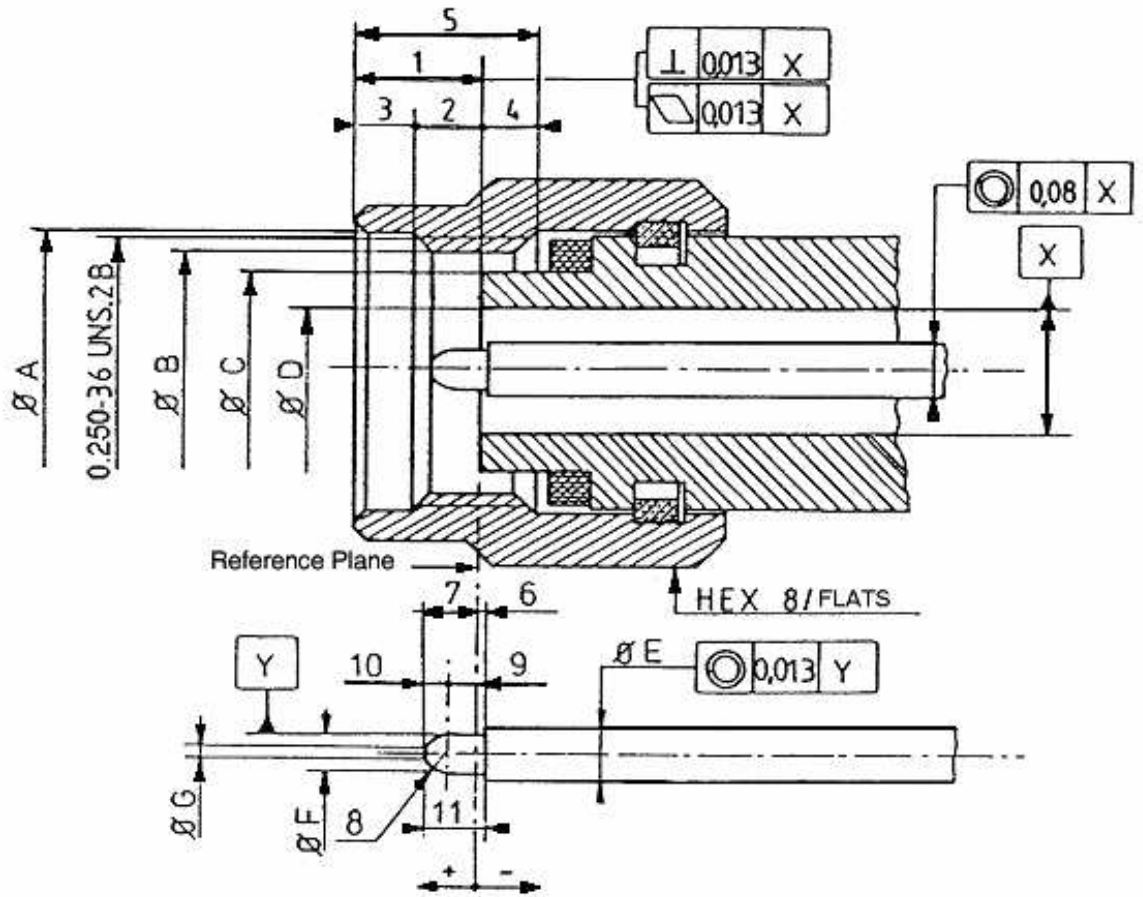

Symbols	Dimensions mm		Notes
	Min	Max	
1	2.63	3.25	
2	1.58	2.2	
3	0.75	1.15	
4	0.85	1.47	
5	3.8	4.2	
6	0	0.08	
7	1.22	1.4	
8	0.8	0.9	Radius
9	0.493	0.784	
10	0.616	0.727	
11	1.3	1.4	
ØA	6.6	6.7	
ØB	5.59	-	
ØC	4.55	4.58	
ØD	2.905	2.94	
ØE	1.26	1.28	
ØF	0.92	0.94	
ØG	0.2	0.34	

Symbols	Dimensions mm		Notes
	Min	Max	
a	3.81	-	
b	1.88	1.98	
c	0	0.08	Contact recess
ØD	5.28	5.49	
Øg	4.6	4.67	
Øh	4.1	4.13	
j	0.13	0.23	2 or more slots
Øk	1.27	1.29	
Øm	0.72	0.84	After closing
n	0.38	1.14	
p	0	0.05	Insert recess
u	2.54	-	
Øt	0.94	0.99	
v	1.91	2.41	
α	-	0.25	45° Chamfer
β	0.99	1.19	45° Chamfer

NOTES:

1. No fillet permitted. Radial undercut 0.2mm maximum deep x 0.89mm maximum long permitted.

Male Interface

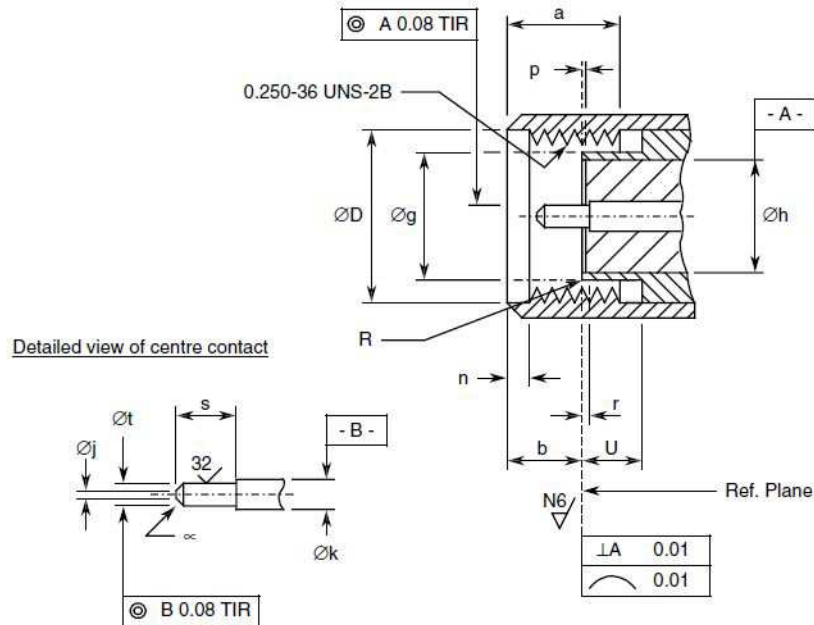

Symbols	Dimensions mm		Notes
	Min	Max	
a	3.71	4.32	
b	2.59	3.35	
ØD	6.48	6.73	
Øg	4.34	4.59	
Øh	4.1	4.13	
Øj	-	0.38	Flat
Øk	1.27	1.29	
n	0.64	1.14	
p	0	0.05	Insert recess
r	0	0.08	Contact recessed
R	-	0.08	Radius
s	2.03	2.29	
Øt	0.9	0.93	
U	2.03	-	
α	-	-	45 ± 3° Chamfer

1.7 MATERIALS AND FINISHES

Materials and finishes shall be as follows:

- a. Shell: Amagnetic Stainless Steel, electro-passivated
- b. Coupling Nut: Amagnetic Stainless Steel, electro-passivated
- c. Centre Contact: Beryllium Copper, with nickel underplate (2µm minimum) and Gold plating (1.3µm minimum)
- d. Inserts: ULTEM 1000
- e. Gaskets: Silicone rubber.

2. REQUIREMENTS

2.1 GENERAL

The complete requirements for procurement of the components specified herein are as stated in this specification and the ESCC Generic Specification. Permitted deviations from the Generic Specification, applicable to this specification only, are listed below.

Permitted deviations from the Generic Specification and this Detail Specification, formally agreed with specific Manufacturers on the basis that the alternative requirements are equivalent to the ESCC requirement and do not affect the component's reliability, are listed in the appendices attached to this specification.

2.1.1 Deviations from the Generic Specification

2.1.1.1 *Deviations from Qualification and Periodic Tests - Chart F4*

- (a) Residual Magnetism: is not applicable
- (b) Power Sensitivity: is not applicable

2.2 MARKING

The marking shall be in accordance with the requirements of ESCC Basic Specification No. 21700 and as follows.

The information to be marked on the component shall be:

- (a) The ESCC qualified components symbol (for ESCC qualified components only).
- (b) The ESCC Component Number.
- (c) Traceability information.

2.3 CONTACT ENGAGEMENT AND SEPARATION FORCES TEST

Ref. Contact Engagement and Separation Forces in the ESCC Generic Specification.

- a) Oversize Test Pin
Pin diameter : 0.95/0.955mm
Insertion depth : 0.76/1.14mm
- b) Maximum Diameter Test Pin
Pin diameter : 0.94/0.946mm
Engagement depth : 1.27/1.9mm
Engagement force: 1380g maximum.
- c) Minimum Diameter Test Pin

Pin diameter : 0.89/0.902mm
 Separation depth: 1.27/1.9mm
 Separation force: 28g minimum.

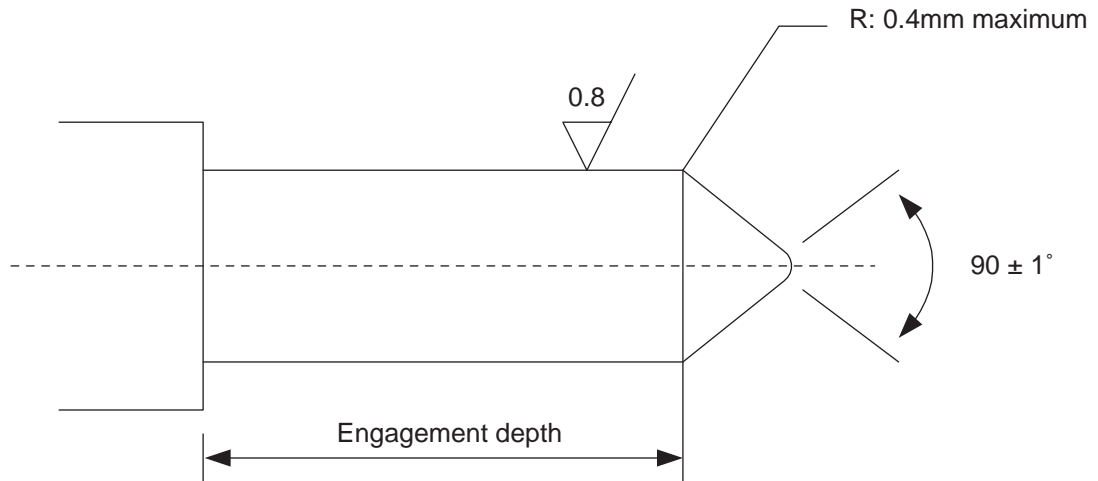

2.4 COUPLING PROOF TORQUE TEST

Ref. Coupling Proof Torque in the ESCC Generic Specification.
 Coupling Proof Torque: 170N.cm.

2.5 MATING AND UNMATING FORCES TEST

Ref. Mating and Unmating Forces in the ESCC Generic Specification.
 Maximum torque during mating or unmating: 24N.cm.

2.6 ELECTRICAL MEASUREMENTS AT ROOM, HIGH AND LOW TEMPERATURES

The measurements shall be performed at room, high and low temperatures.

2.6.1 Room Temperature Electrical Measurements

The measurements shall be performed at $T_{amb}=+22 \pm 3^{\circ}C$.

Characteristics	Symbols	Test Method and Conditions	Limits		Units
			Min	Max	
Voltage Standing Wave Ratio	VSWR	ESCC No. 3403 f = 0 to 31.5GHz	-	1.5	-
Attenuation (spot frequencies)	Att	ESCC No. 3403 f = 2, 17.5, 31.5GHz	Note 1	Note 1	dB
Attenuation (full frequency range)	Att	ESCC No. 3403 f = 0 to 31.5GHz Note 2	Note 1	Note 1	dB
Series Resistance	Rs	f = DC, Note 3 Variant 22 only	3	10	kΩ

NOTES:

1. The limits for Attenuation are as specified in Component Type Variant and Range of Components: Nominal Attenuation + Attenuation Tolerance.
2. Attenuation across full frequency range shall only be tested during Screening Tests during Room Temperature Electrical Measurements.
3. Guranteed but not tested.

2.6.2 High and Low Temperatures Electrical Measurements

The measurements shall be performed at $T_{amb}=+125 (+0 -3) ^\circ\text{C}$ and $T_{amb}=-55 (+3 -0) ^\circ\text{C}$.

Characteristics	Symbols	Test Method and Conditions (Note 1)	Limits		Units
			Min	Max	
Temperature Coefficient of Attenuation (spot frequencies)	TC_{Att}	ESCC No. 3403 $f = 2, 17.5, 31.5\text{GHz}$	-	4×10^{-4}	dB/dB/ $^\circ\text{C}$

NOTES:

1. Measurements shall be performed during Screening Tests on a sample of 2 components. In the event of any failure a 100% inspection shall be performed.

2.7 PARAMETER DRIFT VALUES

Unless otherwise specified, the measurements shall be performed at $T_{amb}=+22 \pm 3^\circ\text{C}$.

Unless otherwise specified, test methods and test conditions shall be as per the corresponding test defined in Room Temperature Electrical Measurements.

The drift values (Δ) shall not be exceeded for each characteristic where specified. The corresponding absolute limit values for each characteristic shall not be exceeded.

Characteristics	Symbols	Drift Value Δ	Units
Voltage Standing Wave Ratio	$\frac{\Delta VSWR}{VSWR}$	± 2	%
Attenuation (spot frequencies)	ΔAtt	± 0.05 or (1) ± 0.5	dB %

NOTES:

1. Whichever is greater.

2.8 INTERMEDIATE AND END-POINT ELECTRICAL MEASUREMENTS

Unless otherwise specified, the measurements shall be performed at $T_{amb}=+22 \pm 3^\circ\text{C}$.

Unless otherwise specified, the test methods and test conditions shall be as per the corresponding test defined in Room Temperature Electrical Measurements.

The drift values (Δ) shall not be exceeded for each characteristic where specified. The corresponding absolute limit values for each characteristic shall not be exceeded.

Test Reference per ESCC No. 3403	Characteristics	Symbols	Limits		Units
			Min	Max	
Vibration Initial Measurements Measurements during last cycle Final Measurements	Attenuation	Att	Note 1	Note 1	dB
	Intermittent contact	-	No discontinuity > 0.5ms No open or short circuit		-
	Attenuation Attenuation Drift (from initial measurement)	Att Δ Att	Note 1 -	Note 1 ± 0.05 or (2) ± 0.5	dB dB %
Mechanical Shock Initial Measurements Final Measurements	Attenuation (Note 3)	Att	Note 1	Note 1	dB
	Attenuation Attenuation Drift (from initial measurement)	Att Δ Att	Note 1 -	Note 1 ± 0.05 or (2) ± 0.5	dB dB %
Rapid Change of Temperature Initial Measurements Final Measurements	Attenuation	Att	Note 1	Note 1	dB
	Attenuation Attenuation Drift (from initial measurement)	Att Δ Att	Note 1 -	Note 1 ± 0.05 or (2) ± 0.5	dB dB %
Climatic Sequence Initial Measurements Measurements during Dry Heat Measurements during Cold Final Measurements	Attenuation (Note 3)	Att	Note 1	Note 1	dB
	Temperature Coefficient of Attenuation	TC_{Att}	-	4×10^{-4}	dB/dB/°C
	Temperature Coefficient of Attenuation	TC_{Att}	-	4×10^{-4}	dB/dB/°C
	Attenuation Attenuation Drift (from initial measurement)	Att Δ Att	Note 1 -	Note 1 ± 0.05 or (2) ± 0.5	dB dB %
Connector Repeatability	Attenuation Attenuation Drift (during test)	Att Δ Att	Note 1 -	Note 1 ± 0.05 or (2) ± 0.5	dB dB %

Test Reference per ESCC No. 3403	Characteristics	Symbols	Limits		Units
			Min	Max	
Operating Life	Attenuation (Note 3)	Att	Note 1	Note 1	dB
Initial Measurements					
Final Measurements	Attenuation Attenuation Drift (from initial measurement)	Att Δ Att	Note 1 -	Note 1 ± 0.05 or (2) ± 0.5	dB dB %
RF Leakage	RF leakage f = 0 to 21.5GHz f = 21.5 to 31.5GHz	E	-70 -60	- -	dBi
Peak Power	Attenuation	Att	Note 1	Note 1	dB
Final Measurements					

NOTES:

1. The limits for attenuation are as specified in Component Type Variants and Range of Components: Nominal Attenuation + Attenuation Tolerance.
2. Whichever is greater.
3. This test need not be repeated. The most recent result from the previous test may be used instead.

2.9 BURN-IN CONDITIONS

Characteristics	Symbols	Test Conditions	Units
Ambient Temperature	T_{amb}	+125	$^{\circ}$ C
Power	P_{in}	0	W

2.10 OPERATING LIFE CONDITIONS

Characteristics	Symbols	Test Conditions	Units
Ambient Temperature	T_{amb}	+25	$^{\circ}$ C
Power	P_{in}	500	mW
Frequency	f_{in}	18	GHz