



Pages 1 to 24

**CONNECTOR SAVERS, ELECTRICAL, RECTANGULAR,
MINIATURE, NON-REMOVABLE SIGNAL CONTACTS, AND
REMOVABLE COAXIAL AND POWER CONTACTS**

BASED ON TYPE D*BM

ESCC Detail Specification No. 3401/080

Issue 3	August 2011
---------	-------------



Document Custodian: European Space Agency - see <https://escies.org>

LEGAL DISCLAIMER AND COPYRIGHT

European Space Agency, Copyright © 2011. All rights reserved.

The European Space Agency disclaims any liability or responsibility, to any person or entity, with respect to any loss or damage caused, or alleged to be caused, directly or indirectly by the use and application of this ESCC publication.

This publication, without the prior permission of the European Space Agency and provided that it is not used for a commercial purpose, may be:

- copied in whole, in any medium, without alteration or modification.
- copied in part, in any medium, provided that the ESCC document identification, comprising the ESCC symbol, document number and document issue, is removed.

DOCUMENTATION CHANGE NOTICE

(Refer to <https://escies.org> for ESCC DCR content)

DCR No.	CHANGE DESCRIPTION
653	Specification upissued to incorporate editorial changes per DCR.

TABLE OF CONTENTS

<u>1.</u>	<u>GENERAL</u>	<u>6</u>
1.1	Scope	6
1.2	Range of Components	6
1.3	Maximum Ratings	6
1.4	Parameter Derating Information	6
1.5	Physical Dimensions	6
<u>2.</u>	<u>APPLICABLE DOCUMENTS</u>	<u>6</u>
<u>3.</u>	<u>TERMS, DEFINITIONS, ABBREVIATIONS, SYMBOLS AND UNITS</u>	<u>7</u>
<u>4.</u>	<u>REQUIREMENTS</u>	<u>14</u>
4.1	General	14
4.2	Deviations from Generic Specification	14
4.2.1	Deviations from Special In-Process Controls	14
4.2.2	Deviations from Final Production Tests (Chart II)	14
4.2.3	Deviations from Burn-in and Electrical Measurements (Chart III)	14
4.2.4	Deviations from Qualification Tests (Chart IV)	14
4.2.5	Deviations from Lot Acceptance Tests (Chart V)	14
4.3	Mechanical Requirements	14
4.3.1	Dimension Check	14
4.3.2	Weight	15
4.3.3	Contact Capability	15
4.3.4	Contact Retention (in Insert)	15
4.3.5	Mating and Unmating Forces	15
4.3.6	Insert Retention (in Shell)	15
4.3.7	Jackscrew Retention	15
4.3.8	Contact Insertion and Withdrawal Forces	15
4.3.9	Engagement and Separation Forces	15
4.3.10	Oversize Pin Exclusion	15
4.3.11	Probe Damage	16
4.3.12	Solderability	16
4.4	Materials and Finishes	16
4.4.1	Shells	16
4.4.2	Inserts	16
4.4.3	Spacers	16
4.4.4	Contacts	16
4.4.5	Contact Retaining Clip	16
4.4.6	Guiding and Locking Devices	16
4.4.7	Magnetism Level	17
4.5	Marking	17
4.5.1	General	17
4.5.2	Contact Position	17
4.5.3	The ESCC Component Number	17
4.5.4	Characteristics	17
4.5.4.1	Series	18
4.5.4.2	Shell Size	18
4.5.4.3	Insert Type	18
4.5.4.4	Contact Arrangements	18
4.5.4.5	Type of Contact	19
4.5.4.6	Magnetism Level	19
4.5.5	Traceability Information	19
4.6	Electrical Measurements	19

4.6.1	Electrical Measurements at Room Temperature	19
4.6.2	Electrical Measurements at High and Low Temperatures (Table 3)	20
4.6.3	Circuit for Electrical Measurements (Figure 4)	20
4.7	Burn-in and Electrical Measurements (Tables 4 and 5)	20
4.8	Environmental and Endurance Tests (Charts IV and V of ESCC Generic Specification No. 3401)	20
4.8.1	Measurements and Inspections on Completion of Environmental Tests	20
4.8.2	Measurements and Inspections at Intermediate Points during Endurance Tests	20
4.8.3	Measurements and Inspections on Completion of Endurance Tests	20
4.8.4	Conditions for Operating Life Test (Part of Endurance Testing)	21
4.8.5	Electrical Circuit for Operating Life Test (Figure 5)	21
4.8.6	Conditions for High Temperature Storage Test (Part of Endurance Testing)	21
APPENDIX 'A'		24

1. **GENERAL**

1.1 **SCOPE**

This specification details the ratings, physical and electrical characteristics, test and inspection data for Connector Savers, Electrical, Rectangular, with Non-Removable Standard (Gauge 20) Signal Contacts, and Removable Coaxial and Power Contacts, based on type D*BM.

It shall be read in conjunction with:

- (a) ESCC Generic Specification No. 3401, Connectors, Electrical, Non-Filtered, Circular and Rectangular.
- (b) ESCC Detail Specification No. 3401/004, Contacts, Coaxial, Crimp-Type, Solder-Type and PCB-Type for 3401/001 Connectors and Male/Female-Type for 3401/080 Connector Savers.
- (c) ESCC Detail Specification No. 3401/040, Contacts, Power, Crimp-Type, Solder-Type and PCB-Type for 3401/001 Connectors and Male/Female-Type for 3401/080 Connector Savers.
- (d) ESCC Detail Specification No. 3401/022, Accessories for Rectangular Connectors, 3401/001, 3401/002 and Connector Savers 3401/020 and 3401/080.
- (e) ESCC Detail Specification No. 3401/085, Fast-Locking Screw Lock Assemblies for Rectangular Connectors 3401/001, 3401/002 and Connector Savers 3401/020, 3401/080.

the requirements of which are supplemented herein.

1.2 **RANGE OF COMPONENTS**

The different sizes of connector savers specified herein, together with their mechanical characteristics, are given in Table 1(a).

1.3 **MAXIMUM RATINGS**

The maximum ratings, which shall not be exceeded at any time during use or storage, applicable to the connector savers specified herein, are scheduled in Table 1(b).

1.4 **PARAMETER DERATING INFORMATION**

The applicable derating information for the connector savers specified herein is shown in Figure 1.

1.5 **PHYSICAL DIMENSIONS**

The physical dimensions of the connector savers specified herein and the available contact arrangements are shown in Figure 2.

2. **APPLICABLE DOCUMENTS**

The following documents form part of this specification and shall be read in conjunction with it:

- (a) ESCC Generic Specification No. 3401, Connectors, Electrical, Non-Filtered, Circular and Rectangular.
- (b) ESCC Detail Specification No. 3401/004, Contacts, Coaxial, Crimp-Type, Solder-Type and PCB-Type for 3401/001 Connectors and Male/Female-Type for 3401/080 Connector Savers.
- (c) ESCC Detail Specification No. 3401/040, Contacts, Power, Crimp-Type, Solder-Type and PCB-Type for 3401/001 Connectors and Male/Female-Type for 3401/080 Connector Savers.
- (d) ESCC Detail Specification No. 3401/022, Accessories for Rectangular Connectors 3401/001, 3401/002 and Connector Savers 3401/020 and 3401/080.
- (e) ESCC Detail Specification No. 3401/085, Fast-Locking Screw Lock Assemblies for Rectangular

- Connectors 3401/001, 3401/002 and Connector Savers 3401/020, 3401/080
- (f) MIL-DTL-24308, Rack and Panel Connectors, Miniature.
 - (g) NASA/GSFC Specification S-311-P-10, Connectors, Electrical, Rectangular, Miniature, Polarised Shell, Rack and Panel, for Space Flight Use.

3. TERMS, DEFINITIONS, ABBREVIATIONS, SYMBOLS AND UNITS

For the purpose of this specification, the terms, definitions, abbreviations, symbols and units specified in ESCC Basic Specification No. 21300 shall apply.

TABLE 1(a) - RANGE OF COMPONENTS

Shell Size (1)	Max. Weight (g) (2)	Mating Force (N max)	Unmating Force	
			N min	N max
E	8.9	30	3.5	20
A	12.4	50	4.5	34
B	14.7	83	8	55
C	18.5	123	11	83
D	20	166	14.5	120

NOTES:

1. See Figure 2(a).
2. Connector weight without contacts or accessories.
3. Total connector weights shall be calculated with:
 - Connector weight (see Table 1(a)).
 - Quantity of Male/Female Signal Contacts used according to Figure 2(b) and weight of contacts: 0.25g (if applicable).
 - Quantity of Male/Female Coaxial or Power Contacts according to Figure 2(b) and weight of contacts given in ESCC Detail Specification No. 3401/004 or 3401/040 (if applicable).
 - Accessories weight given in ESCC Detail Specification Nos. 3401/022 and 3401/085 (if applicable).

TABLE 1(b) - MAXIMUM RATINGS

No.	Characteristics	Symbol	Maximum Rating	Unit	Remarks
1	Working Voltage (Sea Level) Signal Contacts (Gauge 20) Coaxial and Power Contacts	U_R	300 250	Vrms Vrms	Note 1
2	Rated Current Signal Contacts (Gauge 20) and Coaxial Centre Contacts Power Contacts	I_R	7.5 40	A	-
3	Operating Temperature Range	T_{op}	-55 to +125	°C	T_{amb}
4	Storage Temperature Range	T_{stg}	-65 to +125	°C	-

NOTES:

1. Between contact and shell.

FIGURE 1 - PARAMETER DERATING INFORMATION

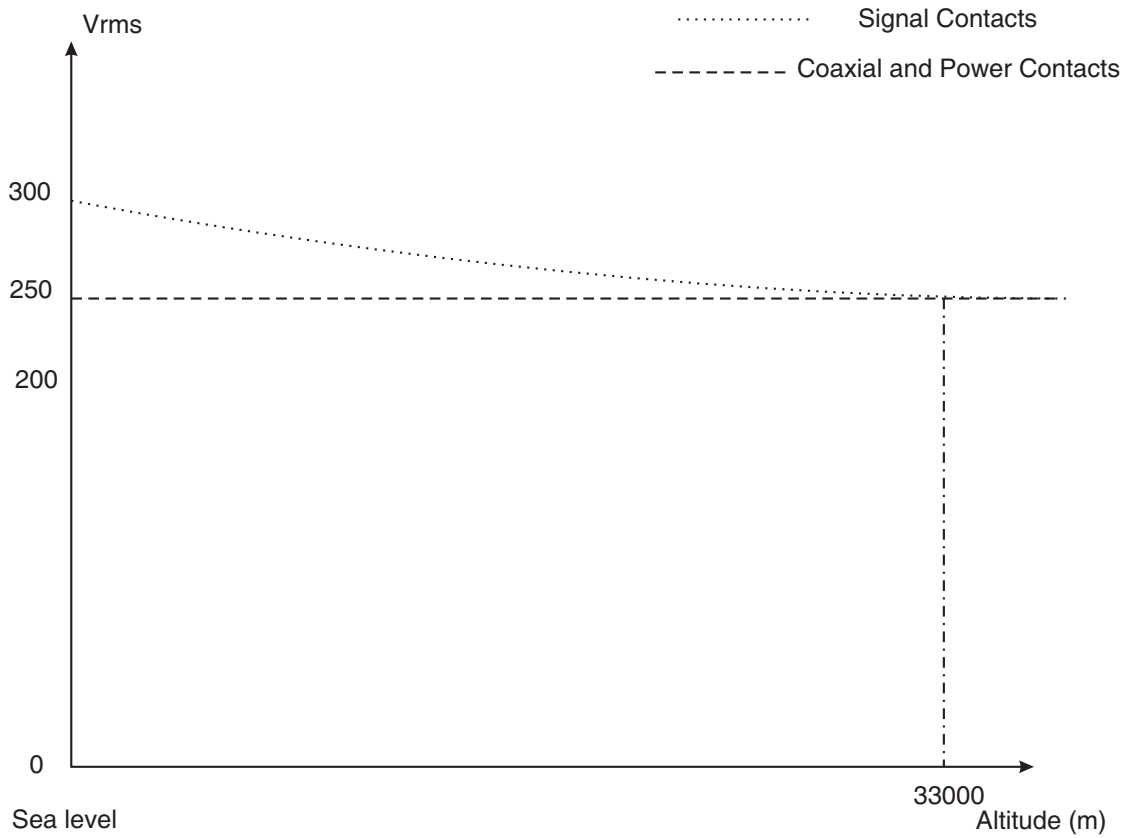

Working Voltage versus Altitude

FIGURE 2 - PHYSICAL DIMENSIONS
FIGURE 2(a) - CONNECTOR SAVER

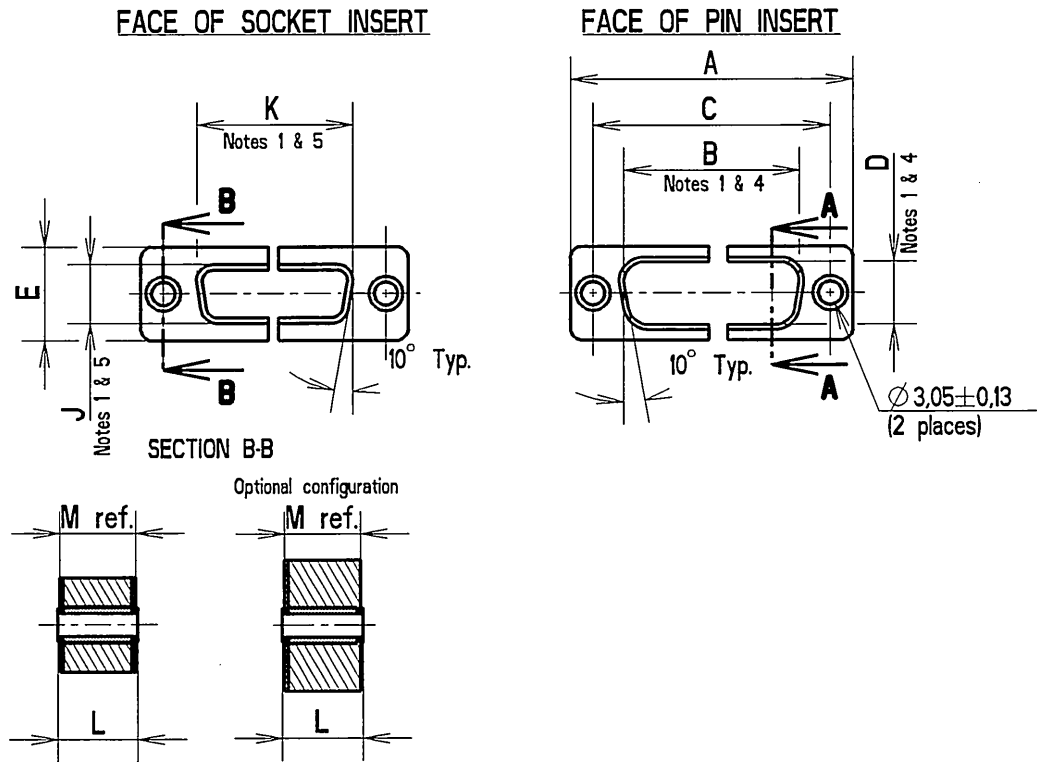

SECTION A-A SIGNAL CONTACTS (GAUGE 20)

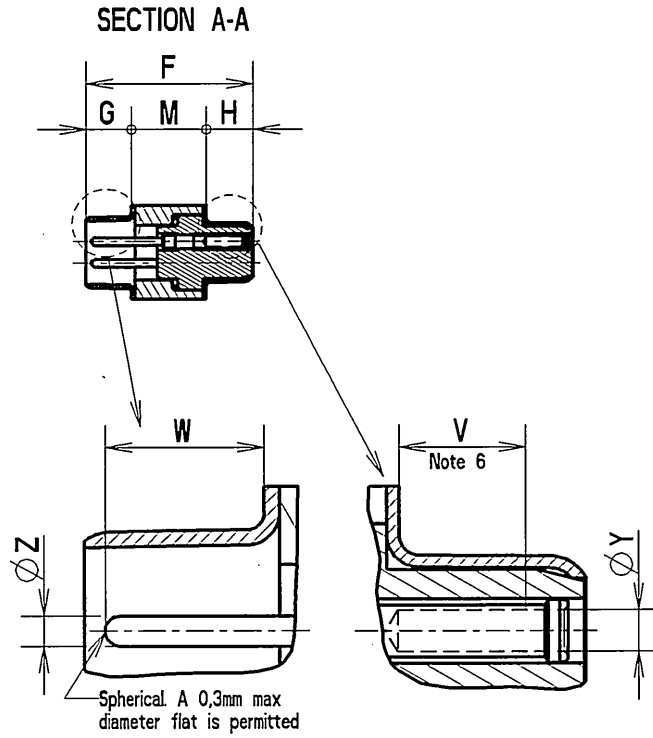

SECTION A-A COAXIAL CONTACTS

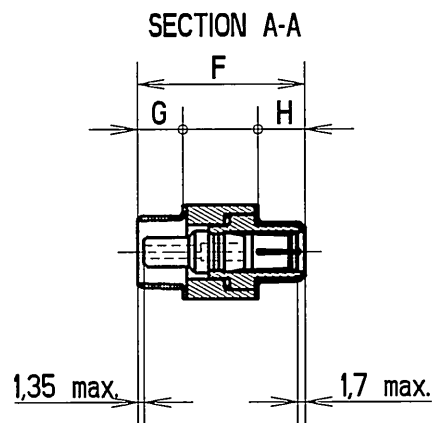

SECTION A-A POWER CONTACTS

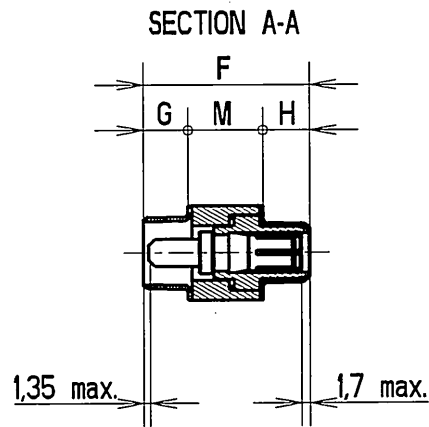

Shell Size	Dim.	A	B	C	D	E	F	G	H	J	K	L	M	V	W	øY	øZ
E	Min.	30.43	16.79	24.87	8.23	12.17	21.62	5.82	6.05	7.77	16.21	10.21	9.61	3.63	4.03	1.07	0.99
	Max.	31.19	17.04	25.12	8.48	12.93	22.12	6.05	6.3	8.03	16.46	10.97	10.11	-	-	1.14	1.04
A	Min.	38.76	25.12	33.2	8.23	12.17	21.62	5.82	6.05	7.77	24.54	10.21	9.61	3.63	4.03	1.07	0.99
	Max.	39.52	25.37	33.45	8.48	12.93	22.12	6.05	6.3	8.03	24.79	10.97	10.11	-	-	1.14	1.04
B	Min.	52.65	38.84	46.91	8.23	12.17	21.72	5.69	6.05	7.77	38.25	10.21	9.61	3.63	4.03	1.07	0.99
	Max.	53.42	39.09	47.17	8.48	12.93	22.22	5.99	6.3	8.03	38.51	10.97	10.11	-	-	1.14	1.04
C	Min.	68.94	55.3	63.37	8.23	12.17	21.72	5.69	6.05	7.77	54.71	10.21	9.61	3.63	4.03	1.07	0.99
	Max.	69.7	55.55	63.63	8.48	12.93	22.22	5.99	6.3	8.03	54.97	10.97	10.11	-	-	1.14	1.04
D	Min.	66.55	52.68	60.99	11.07	14.99	21.72	5.69	6.05	10.62	52.3	10.21	9.61	3.63	4.03	1.07	0.99
	Max.	67.31	52.93	61.24	11.33	15.75	22.22	5.99	6.3	10.87	52.55	10.97	10.11	-	-	1.14	1.04

NOTES:

1. Dimensions B, D, J and K pertain to front and rear shell keystone and are taken at bottom of draw.
2. All dimensions are in millimetres (angles in degrees).
3. Underlined dimensions, in Table, are critical to ensure mateability.
4. Inside dimension for male side.
5. Outside dimension for female side.
6. Electrical contact position in female contact.

FIGURE 2(b) - CONTACT ARRANGEMENTS
SIGNAL CONTACT ARRANGEMENTS - (FRONT VIEW MALE INSERT)

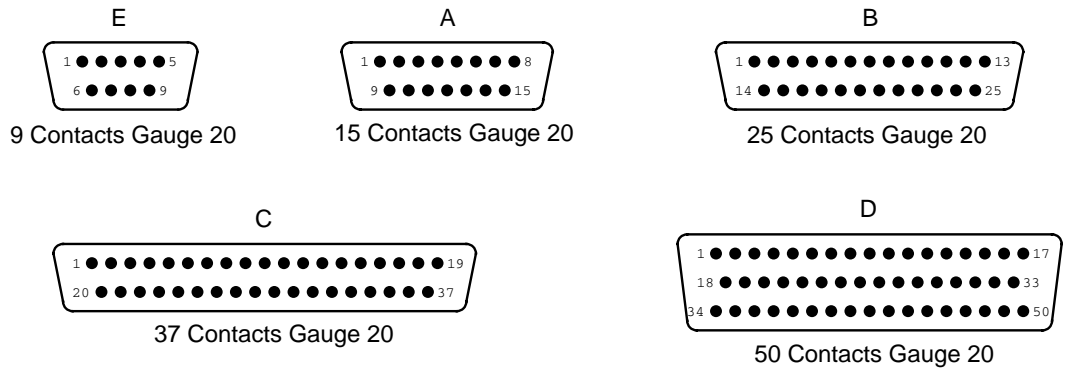

COAXIAL AND POWER CONTACT ARRANGEMENTS - (FRONT VIEW MALE INSERT)

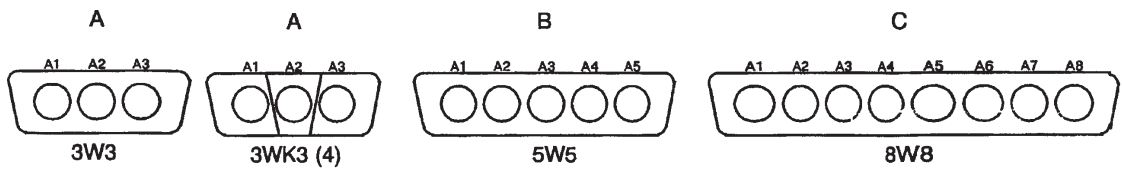

MIXED SIGNAL AND COAXIAL OR POWER CONTACT ARRANGEMENTS (FRONT VIEW MALE INSERT)

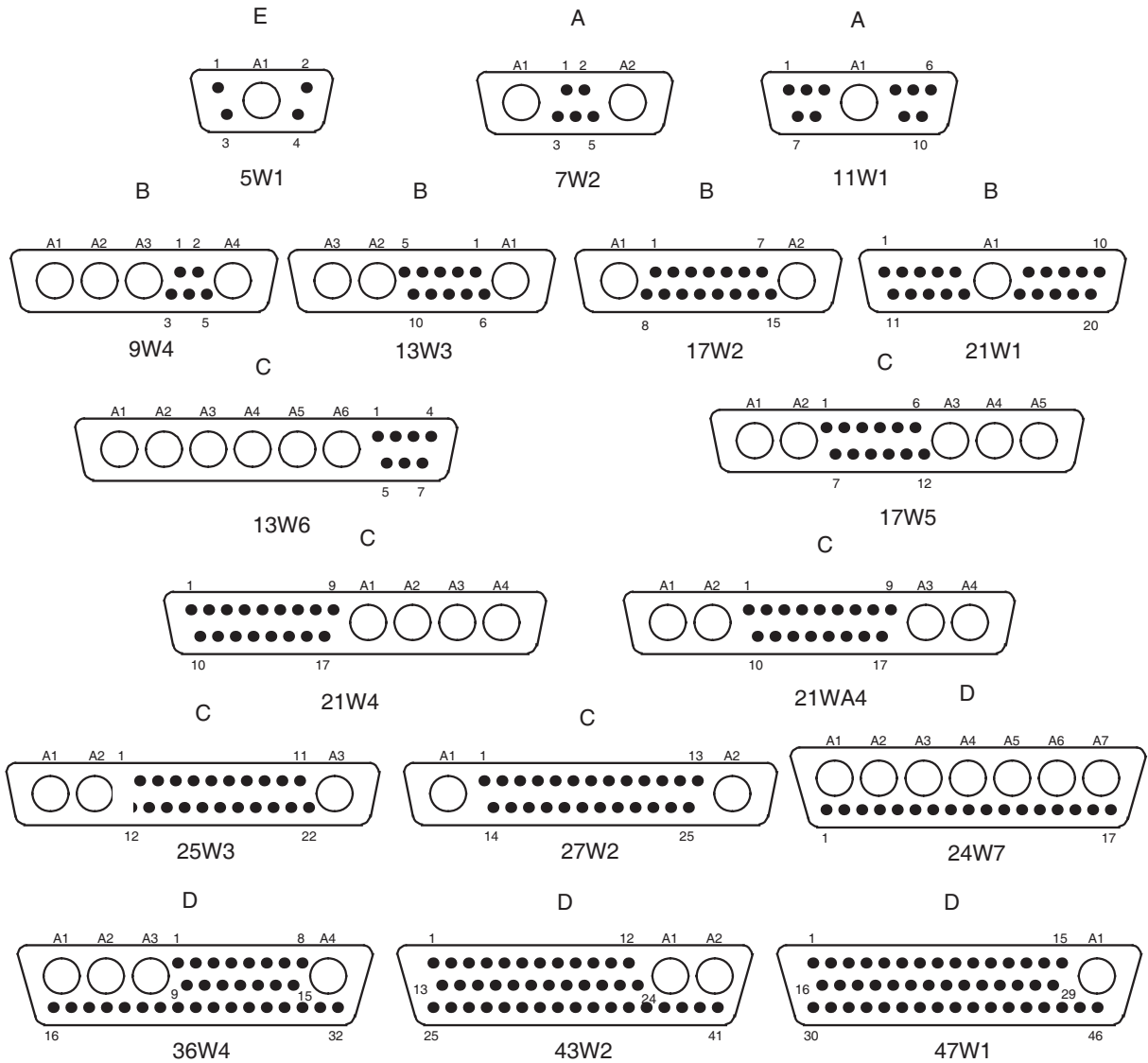

NOTES:

1. Contact locations are in conformity with MIL-DTL-24308 specification sheets for standard signal contact arrangements and NASA/GSFC Specification S-311-P-10 for coaxial, power and mixed contact arrangements, and shall not be checked during procurement.
2. Both sides of the insert shall be marked with the minimum marking shown. Contact numbers are shown outside the inserts for readability.
3. See Para. 4.5 for definition of letters and numbers.
4. 3WK3 insulator with built-in keying (middle part recessed or protruding with respect to each side), to avoid mismounting (K=keyed).

4. REQUIREMENTS

4.1 GENERAL

The complete requirements for procurement of the connectors specified herein are stated in this specification and ESCC Generic Specification No. 3401. Deviations from the Generic Specification, applicable to this specification only, are listed in Para. 4.2.

Deviations from the applicable Generic Specification and this Detail Specification, formally agreed with specific Manufacturers on the basis that the alternative requirements are equivalent to the ESCC requirements and do not affect the components' reliability, are listed in the appendices attached to this specification.

4.2 DEVIATIONS FROM GENERIC SPECIFICATION

4.2.1 Deviations from Special In-Process Controls

None

4.2.2 Deviations from Final Production Tests (Chart II)

- (a) Para. 9.1.1.4, Mated Shell Conductivity: Not applicable.
- (b) Para. 9.9, Seal Test: Not applicable.

4.2.3 Deviations from Burn-in and Electrical Measurements (Chart III)

Not applicable.

4.2.4 Deviations from Qualification Tests (Chart IV)

- (a) Para. 9.1.1.4, Mated Shell Conductivity: Not applicable.
- (b) Para. 9.9, Seal Test: Not applicable.
- (c) Para. 9.10, Wiring: Not applicable.
- (d) Para. 9.24, Jackscrew Retention: Not applicable.
- (e) Para. 9.27, Maintenance Aging: Not applicable to signal contacts.

4.2.5 Deviations from Lot Acceptance Tests (Chart V)

- (a) Para. 9.1.1.4, Mated Shell Conductivity: Not applicable.
- (b) Para. 9.9, Seal Test: Not applicable.
- (c) Para. 9.10, Wiring: Not applicable.

4.3 MECHANICAL REQUIREMENTS

4.3.1 Dimension Check

The dimensions of the connector savers specified herein shall be verified in accordance with the requirements set out in Para. 9.6 of ESCC Generic Specification No. 3401 and shall conform to those shown in Figure 2 of this specification. Only the underlined dimensions shall be checked during procurement.

4.3.2 Weight

The maximum weight of the connector savers specified herein, without contacts or accessories, shall be as specified in Table 1(a).

4.3.3 Contact Capability

For the purpose of this test, the pick-up and drop weights shall be as follows.

Contacts	Measurements	Pick-Up Weight	Drop Weight
Signal Contacts (Gauge 20)	Weight (g)	28.35	226.8
	Pin diameter (mm)	0.99 to 0.993	1.039 to 1.04
	Insertion depth (mm)	4.0	4.0

See ESCC Detail Specification Nos. 3401/004 and 3401/040 for coaxial and power contacts.

4.3.4 Contact Retention (in Insert)

The contact retention force of signal contacts within the insert shall be 40N. See ESCC Detail Specification Nos. 3401/004 and 3401/040 for coaxial and power contacts.

4.3.5 Mating and Unmating Forces

The forces applied for the mating and unmating of the connector savers shall conform to the values specified in Table 1(a).

4.3.6 Insert Retention (in Shell)

Connector saver inserts shall withstand a pressure of 42.8N/cm² without being dislodged from the shell.

4.3.7 Jackscrew Retention

Not applicable.

4.3.8 Contact Insertion and Withdrawal Forces

Not applicable to signal contacts. See ESCC Detail Specification Nos. 3401/004 and 3401/040 for coaxial and power contacts.

4.3.9 Engagement and Separation Forces

The engagement and separation forces of the female signal contacts shall be tested with the applicable test pin and shall not exceed the values of the table hereunder.

Contacts	Measurements	Diameter (mm)		Engagement Max (N)	Separation (N)	
		Min.	Max.		Min.	Max.
Signal	Max Ø Test Pin	1.039	1.04	3.33	-	2.22
	Min Ø Test Pin	0.99	0.993	-	0.28	-

See ESCC Detail Specification Nos. 3401/004 and 3401/040 for coaxial and power contacts.

4.3.10 Oversize Pin Exclusion

The diameter of the test pin and the force applied to it shall be as follows.

Contacts	Test Pin Dia. (mm)		Force (N) Max.
	Min.	Max.	
Signal	1.166	1.17	3.33

See ESCC Detail Specification Nos. 3401/004 and 3401/040 for coaxial and power contacts.

4.3.11 Probe Damage

The probe diameter and the moment at the end of the probe shall be as follows.

Contacts	Probe Dia. (mm)		Moment (N.cm)
	Min.	Max.	
Signal	1.007	1.033	5.65

See ESCC Detail Specification Nos. 3401/004 and 3401/040 for coaxial and power contacts.

4.3.12 Solderability

Not applicable.

4.4 MATERIALS AND FINISHES

The materials and finishes shall be as specified herein. Where a definite material is not specified, a material which will enable the components specified herein to meet the performance requirements of this specification shall be used. Acceptance or approval of any constituent material does not guarantee acceptance of the finished product.

4.4.1 Shells

Shells shall be made of brass. The plating shall be 0.7µm minimum of gold over 1.0µm of copper.

4.4.2 Inserts

Inserts shall be made of glass-fibre filled diallylphtathalate resin or a suitable thermoplastic material.

4.4.3 Spacers

Spacers shall be made of polyimide material.

4.4.4 Contacts

The contacts shall be made of copper base alloy selected from raw materials with a minimum of impurities. Gold plating thickness shall be 1.27µm minimum over 1.0µm of copper.

The female spring element shall be made of copper base alloy selected from raw materials with a minimum of impurities. Gold plating thickness shall be 1.27µm minimum over 1.0µm of copper or nickel.

4.4.5 Contact Retaining Clip

Not applicable to signal contacts. See ESCC Specification Nos. 3401/004 and 3401/040 for coaxial and power contacts.

4.4.6 Guiding and Locking Devices

As specified in ESCC Detail Specification Nos. 3401/022 and 3401/085.

4.4.7 Magnetism Level

The allowable value of magnetism shall not exceed that specified for the relevant level (see Para. 4.5.4.6). Only magnetism levels NMC and NMD are verified.

4.5 MARKING

4.5.1 General

The marking of components delivered to this specification shall be in accordance with the requirements of ESCC Basic Specification No. 21700 and the following paragraphs. When the component is too small to accommodate all of the marking specified, as much as space permits shall be marked and the marking information, in full, shall accompany the component in its primary package.

Each component shall be marked in respect of:

- (a) Contact Position.
- (b) The ESCC Component Number.
- (c) Characteristics.
- (d) Traceability Information.

4.5.2 Contact Position

Contact position shall be marked on the inserts in accordance with Figure 2(b).

4.5.3 The ESCC Component Number

Each component shall bear the ESCC Component Number which shall be constituted and marked as follows:

340108001B

- Detail Specification Number: 3401080
- Type Variant (See Note 1): 01
- Testing Level: B

NOTES:

1. Marking of the Type Variant is mandatory. No further reference to Type Variant is made in this specification.

4.5.4 Characteristics

The characteristics to be marked in the following order of precedence are:

- (a) Series.
- (b) Shell Size.
- (c) Insert Type.
- (d) Contact Arrangement.
- (e) Type of Contact.
- (f) Magnetism Level.
- (g) Contact Information.

The information shall be constituted and marked as follows (example): DABM7W2PSNMB

- Series: D
- Shell size: A
- Insert type: BM
- Contact Arrangement: 7W2
- Type of Contact: PS
- Magnetism Level (200 gamma): NMB

4.5.4.1 *Series*

This connector saver series shall be designated by the letter D.

4.5.4.2 *Shell Size*

Shell size shall be indicated by the letters specified hereafter.

Code	E	A	B	C	D
------	---	---	---	---	---

4.5.4.3 *Insert Type*

The insert type is defined by the letters BM.

4.5.4.4 *Contact Arrangements*

The number of contacts shall be as shown in Figure 2(b) and contact arrangements shall be indicated by the codes specified hereafter:-

Code	Shell Size	Number of Signal Contacts	Number of Coaxial or Power Contact Cavities (Note 1)
9	E	9	0
5W1	E	4	1
15	A	15	0
3W3	A	0	3
3WK3	A	0	3
7W2	A	5	2
11W1	A	10	1
25	B	25	0
5W5	B	0	5
9W4	B	5	4
13W3	B	10	3
17W2	B	15	2
21W1	B	20	1
37	C	37	0
8W8	C	0	8
13W6	C	7	6
17W5	C	12	5
21WA4	C	17	4 (2)
21W4	C	17	4 (2)

Code	Shell Size	Number of Signal Contacts	Number of Coaxial or Power Contact Cavities (Note 1)
25W3	C	22	3
27W2	C	25	2
50	D	50	0
24W7	D	17	7
36W4	D	32	4
43W2	D	41	2
47W1	D	46	1

NOTES:

- For connectors with contact arrangements that include coaxial or power contact cavities, the coaxial or power contacts shall be ordered separately in accordance with ESCC Detail Specification Nos. 3401/004 and 3401/040 respectively. Coaxial and power contacts must be from the same Manufacturer as the connector in which they are mounted and this shall be verified prior to assembly.
- See Figure 2(b) for physical differences.

4.5.4.5 *Type of Contact*

The contact types shall be indicated by the following code letters.

Code Letter	Contact Type
PS	Male/Female

4.5.4.6 *Magnetism Level*

The following codes shall be used for magnetism level:.

Code	Definition
NMB	Magnetism Level: ≤ 200 gamma
NMC	Magnetism Level: ≤ 20 gamma
NMD	Magnetism Level: ≤ 2 gamma

4.5.5 Traceability Information

Traceability information shall be marked in accordance with the requirements of ESCC Basic Specification No. 21700

4.6 ELECTRICAL MEASUREMENTS

4.6.1 Electrical Measurements at Room Temperature

The parameters to be measured in respect of electrical characteristics are scheduled in Table 2. Unless otherwise specified, the measurement shall be performed at $T_{amb} = +22 \pm 3^{\circ}C$.

4.6.2 Electrical Measurements at High and Low Temperatures (Table 3)

Not applicable.

4.6.3 Circuit for Electrical Measurements (Figure 4)

Not applicable

4.7 BURN-IN AND ELECTRICAL MEASUREMENTS (TABLES 4 AND 5)

Not applicable.

Table 2 - ELECTRICAL MEASUREMENTS AT ROOM TEMPERATURE

No.	Characteristic	Symbol	ESCC 3401 Test Method	Test Condition	Limits		Unit
					Min	Max	
1	Insulation Resistance	R_I	Para. 9.1.1.1	Para. 9.1.1.1	5000	-	$M\Omega$
2	Voltage Proof Leakage Current	I_L	Para. 9.1.1.2	Note 1	-	2	mA
3	Low Level Contact Resistance	R_{CL}	Para. 9.1.1.3	Para. 9.1.1.3 Signal Contacts Coaxial and Power Contacts	- -	6 Note 2	$m\Omega$
4	Rated Current Contact Resistance	R_{CR}	Para. 9.1.1.3	Para. 9.1.1.3 Signal Contacts: 7.5A Coaxial and Power Contacts	- -	5 Note 2	$m\Omega$

NOTES:

- Signal Contacts: 1250 Vrms.
Power and Straight Coaxial Contacts: 1000 Vrms.
90° Coaxial Contacts: 800 Vrms.
For mixed contact arrangements, the voltage applied between dissimilar contacts shall be the higher that would be applied between either of the contacts in question tested with an identical contact.
- See ESCC Detail Specification Nos. 3401/004 and 3401/040 for coaxial and power contacts.

TABLES 3, 4 AND 5

Not applicable.

4.8 ENVIRONMENTAL AND ENDURANCE TESTS (CHARTS IV AND V OF ESCC GENERIC SPECIFICATION NO. 3401)

4.8.1 Measurements and Inspections on Completion of Environmental Tests

The parameters to be measured and inspections to be performed on completion of environmental testing shall be those specified in Table 6. Unless otherwise specified, these measurements shall be performed at $T_{amb} = +22 \pm 3^{\circ}C$.

4.8.2 Measurements and Inspections at Intermediate Points during Endurance Tests

Not applicable.

4.8.3 Measurements and Inspections on Completion of Endurance Tests

The parameters to be measured and inspections to be performed on completion of endurance testing shall be those specified in Table 6. Unless otherwise specified, the measurements shall be performed at

$T_{amb} = +22 \pm 3^{\circ}C$.

4.8.4 Conditions for Operating Life Test (Part of Endurance Testing)

Not applicable.

4.8.5 Electrical Circuit for Operating Life Test (Figure 5)

Not applicable.

4.8.6 Conditions for High Temperature Storage Test (Part of Endurance Testing)

The requirements for the high temperature storage test are specified in Section 9 of ESCC Generic Specification No. 3401. The temperature to be applied shall be the maximum storage temperature specified in Table 1(b) of this specification.

Table 6 - MEASUREMENTS AND INSPECTIONS ON COMPLETION OF ENVIRONMENTAL AND ENDURANCE TESTING

No.	ESCC Generic Spec. No. 3401		Measurements and Inspections		Symbol	Limits		Unit
	Environmental and Endurance Tests Note 1	Test Method and Conditions	Identification	Conditions		Min	Max	
01	Seal Test	Para. 9.9	Not applicable	-	-	Not applicable		-
02	Wiring	Para. 9.10	Not applicable	-	-	-	-	-
03	Vibration	Para. 9.11	Initial Measurements Coupling screw(s) Unlocking Torque Final Measurements Full Engagement Coupling screw(s) Unlocking Torque Drift Visual Examination	- - -	- - -	Not applicable Not applicable -		- - -
04	Shock or Bump	Para. 9.12	Full Engagement Visual Examination	-	-	-	-	-
05	Climatic Sequence	Para. 9.13	Dry Heat Insulation Resistance Low Air Pressure Voltage Proof Leakage Current Damp Heat Insulation Resistance Final Measurements External Visual Inspection Insulation Resistance Voltage Proof Leakage Current	Table 2, Item 1 Figure 1 Immediately after test Table 2, Item 1 After 1-24 hrs Recovery ESCC 3401 Para. 9.7 Table 2, Item 1 Table 2, Item 2	R_I I_L R_I R_I I_L	1000 Table 2 Item 2 100 ESCC 3401 Para. Para. 9.7 Table 2, Item 1 Table 2, Item 2	 - - - mA - MΩ mA MΩ	
06	Plating Thickness	Para. 9.14	Thickness	-	-	Para. 4.4.4 of this spec.		-
07	Joint Strength	Para. 9.15	ESCC 3401 Para. 9.15	-	-	ESCC 3401 Para. 9.15		-
08	Rapid Change of Temperature	Para. 9.16	Visual Examination	-	-	-	-	-

No.	ESCC Generic Spec. No. 3401		Measurements and Inspections		Symbol	Limits		Unit
	Environmental and Endurance Tests Note 1	Test Method and Conditions	Identification	Conditions		Min	Max	
			Insulation Resistance Voltage Proof Leakage Current	Table 2, Item 1 Table 2, Item 2	R_I I_L	Table 2, Item 1 Table 2, Item 2		M Ω mA
09	Contact Retention (in Insert)	Para. 9.17 & Para. 4.3.4 of this spec.	Contact Displacement	-	-	ESCC 3401 Para. 9.17		-
10	Endurance	Para. 9.18	Initial Measurements Mating/Unmating Forces Low Level Contact Resistance Mated Shell Conductivity Final Measurements Visual Examination Mating/Unmating Forces Low Level Contact Resistance Drift Mated Shell Conductivity Insulation Resistance Voltage Proof Leakage Current	- Table 2, Item 3 - - - Table 2, Item 3 - Table 2, Item 1 Table 2, Item 2	F R_{CL} - - F ΔR_{CL} - R_I I_L	Para. 4.3.5 of this spec. Record Values Not applicable - - Para. 4.3.5 of this spec. - 3 Not applicable Table 2, Item 1 Table 2, Item 2		N m Ω - - N m Ω - M Ω mA
11	Permanence of Marking	Para. 9.19	As applicable	-	-	- -		-
12	Mating/Unmating Forces	Para. 9.20	Force	-	F	Para. 4.3.5 of this spec		N
13	High Temperature Storage	Para. 9.21	Initial Measurements Low Level Contact Resistance Mated Shell Conductivity Final Measurements Visual Examination Mating/Unmating Forces Low Level Contact Resistance Drift Rated Current Contact Resistance Mated Shell Conductivity Insulation Resistance Voltage Proof Leakage Current Contact Retention (in Insert)	Table 2, Item 3 - - - Table 2, Item 3 Table 2, Item 4 - Table 2, Item 1 Table 2, Item 2 Para. 4.3.4 of this spec.	R_{CL} - - F ΔR_{CL} $R_{CR}V_{cc}$ m Ω - R_I I_L -	Record Values Not applicable - - Para. 4.3.5 of this spec. - 3 Table 2, Item 4 Not applicable Table 2, Item 1 Table 2, Item 2 ESCC 3401 Para. 9.17		m Ω - - N m Ω - M Ω mA N
14	Corrosion	Para. 9.22	Visual Examination	-	-	- -		-
15	Insert Retention (in Shell)	Para. 9.23 & Para. 4.3.6 of this spec.	Visual Examination	-	-	Para. 4.3.6 of this spec.		-
16	JackscREW Retention	Para. 9.24 and 4.3.7 of this spec	Visual Examination	-	-	Not applicable		-

No.	ESCC Generic Spec. No. 3401		Measurements and Inspections		Symbol	Limits		Unit
	Environmental and Endurance Tests Note 1	Test Method and Conditions	Identification	Conditions		Min	Max	
17	High Temperature Measurements	Para. 9.25	Insulation Resistance	Table 2 Item 1	R _I	500	-	MΩ
18	Overload Test	Para. 9.26	Internal Temperature	-	T	-	+100	°C
			Rated Current Contact Resistance	Table 2, Item 4	R _{CR}	Table 2, Item 4		mΩ
			Mated Shell Conductivity	-	-	Not applicable		-
			Insulation Resistance	Table 2 Item 1	R _I	Table 2, Item 1		MΩ
			Voltage Proof Leakage Current	Table 2 Item 2	I _L	Table 2, Item 2		mA
19	Maintenance Aging	Para. 9.27	Visual Examination	-	-	-	-	-
			Contact Retention (in Insert)	Para. 4.3.4 of this spec.	-	ESCC 3401 Para. 9.17		N
			Contact insertion and withdrawal forces	Para. 4.3.8 of this spec.	F	Para. 4.3.8		N
20	Engage/Separation Forces	Para. 9.28 & Para. 4.3.9 of this spec.	Force	-	F	Para. 4.3.9		N
21	Oversize Pin Exclusion	Para. 9.29 and 4.3.10 of this spec.	-	-	-	ESCC 3401 Para. 9.29		-
22	Probe Damage	Para. 9.30 and 4.3.11 of this spec.	Contact Separation Force	Para. 4.3.9 of this spec.	-	Para. 4.3.9		-
23	Solderability	Para. 9.31 & Para. 4.3.12 of this spec.	-	-	-	Not applicable		-

NOTES:

1. The tests in this Table refer to either Chart IV or V and shall be used as applicable.

APPENDIX 'A'**AGREED DEVIATIONS FOR C&K COMPONENTS (F)**

ITEMS AFFECTED	DESCRIPTION OF DEVIATIONS
Para. 4.2.2	Para. 9.3, Contact Retainer Test may be omitted provided that a 100% external visual inspection of the contact retainer clips positioned within the insert is performed in accordance with the C&K COMPONENTS PID requirements.