



Pages 1 to 8

RADIOGRAPHIC INSPECTION OF RESISTORS

ESCC Basic Specification No. 2094000

Issue 1	October 2002
---------	--------------



Document Custodian: European Space Agency - see <https://escies.org>

LEGAL DISCLAIMER AND COPYRIGHT

European Space Agency, Copyright © 2003. All rights reserved.

The European Space Agency disclaims any liability or responsibility, to any person or entity, with respect to any loss or damage caused, or alleged to be caused, directly or indirectly by the use and application of this ESCC publication.

This publication, without the prior permission of the European Space Agency and provided that it is not used for a commercial purpose, may be:

- copied in whole, in any medium, without alteration or modification.
- copied in part, in any medium, provided that the ESCC document identification, comprising the ESCC symbol, document number and document issue, is removed.



DOCUMENTATION CHANGE NOTICE

(Refer to <https://escies.org> for ESCC DCR content)

DCR No.	CHANGE DESCRIPTION



TABLE OF CONTENTS

<u>1.</u>	<u>SCOPE</u>	<u>5</u>
<u>2.</u>	<u>GENERAL REQUIREMENTS</u>	<u>5</u>
2.1	Applicability	5
2.2	Procedure	5
<u>3.</u>	<u>X-RAY PHOTOGRAPHS</u>	<u>5</u>
3.1	Resistors Wirewound	5
<u>4.</u>	<u>DETAILED REQUIREMENTS</u>	<u>5</u>
4.1	General	5
4.2	Resistors Wirewound	5
4.2.1	Winding	5
4.2.2	End Cap and Lead	5
4.2.3	Assembly	6
<u>5.</u>	<u>FIGURES</u>	<u>7</u>
5.1	Figure 1: Component/Exposure Orientation	7
5.2	Figure 2: Typical Component	8
5.3	Figure 3: Possible Defects	8

1. **SCOPE**

This specification, to be read in conjunction with ESCC Basic Specification No. 20900, Radiographic Inspection, contains additional requirements for Resistors.

2. **GENERAL REQUIREMENTS**

2.1 **APPLICABILITY**

The following criteria may not be varied or modified after commencement of any inspection stage. Any ambiguity or proposed minor deviation shall be referred to the ESCC Executive for resolution and approval.

2.2 **PROCEDURE**

All items shall be examined in such a manner that a minimum of handling and movement of the components is involved.

3. **X-RAY PHOTOGRAPHS**

3.1 **RESISTORS WIREWOUND**

Each component shall be radiographed once in each of the 2 directions shown in Figure 1. Figure 2 shows the appearance of a typical component and indicates the terms used in this specification.

4. **DETAILED REQUIREMENTS**

4.1 **GENERAL**

A component shall be rejected if it exhibits one or more of the defects listed in the following paragraphs.

4.2 **RESISTORS WIREWOUND**

The drawing (Figure 3) is included to provide additional explanatory material, but shall be considered as an example only.

4.2.1 **Winding**

- (a) Resistance wire turns not evenly spaced.
- (b) Resistance wire winding not snug against the core.
- (c) Average winding pitch exceeding five times the wire diameter.
- (d) Effective wire coverage such that more than 20% of the overall winding area remains uncovered.
- (e) Broken wire.

NOTES:

The effective wire coverage is the winding length on the core between the points of departure from the normal winding pitch.

4.2.2 **End Cap and Lead**

- (a) Kinked lead.
- (b) Distorted butt weld.
- (c) End cap out of perpendicular alignment with axis of resistor element by more than five degrees.

- (d) Cap improperly fitted by loose on core.

4.2.3 Assembly

- (a) Extraneous material in contact with resistance wire.
- (b) Resistor element offset from axis of component by more than 10%.
- (c) Extraneous material in filler or body greater than 25% of wall thickness in any dimension.
- (d) Voids in filler or body greater than 25% of wall thickness in any dimension.
- (e) Wall thickness of filler or body not meeting the requirements of the approved PID.

5. **FIGURES**

5.1 **FIGURE 1: COMPONENT/EXPOSURE ORIENTATION**

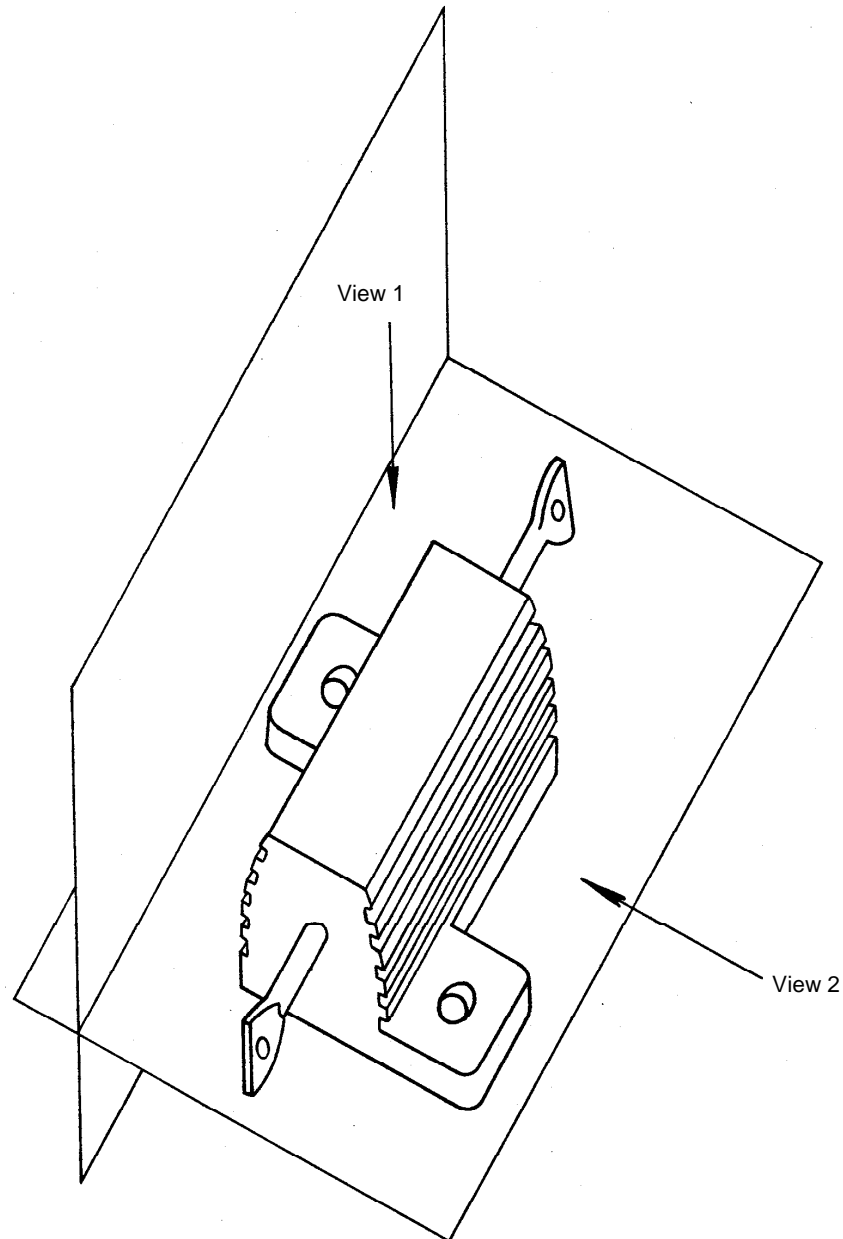

5.2 FIGURE 2: TYPICAL COMPONENT

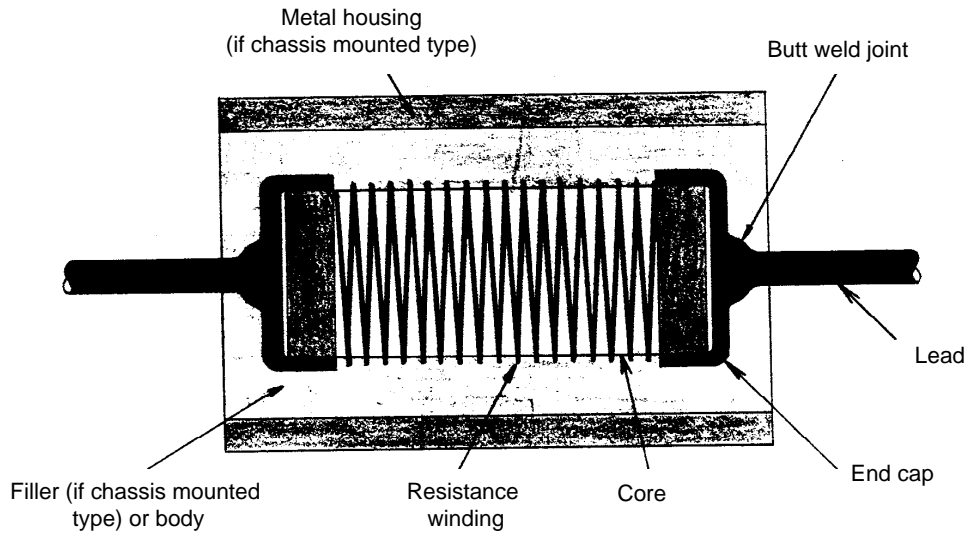

5.3 FIGURE 3: POSSIBLE DEFECTS

