



Pages 1 to 17

DIODE, SILICON, POWER SCHOTTKY RECTIFIER,

BASED ON TYPE 1N5819

ESCC Detail Specification No. 5106/021

Issue 1	May 2010
---------	----------



Document Custodian: European Space Agency - see <https://escies.org>

LEGAL DISCLAIMER AND COPYRIGHT

European Space Agency, Copyright © 2010. All rights reserved.

The European Space Agency disclaims any liability or responsibility, to any person or entity, with respect to any loss or damage caused, or alleged to be caused, directly or indirectly by the use and application of this ESCC publication.

This publication, without the prior permission of the European Space Agency and provided that it is not used for a commercial purpose, may be:

- copied in whole, in any medium, without alteration or modification.
- copied in part, in any medium, provided that the ESCC document identification, comprising the ESCC symbol, document number and document issue, is removed.

DOCUMENTATION CHANGE NOTICE

(Refer to <https://escies.org> for ESCC DCR content)

DCR No.	CHANGE DESCRIPTION

TABLE OF CONTENTS

<u>1.</u>	<u>GENERAL</u>	<u>5</u>
1.1	Scope	5
1.2	Applicable Documents	5
1.3	Terms, Definitions, Abbreviations, Symbols and Units	5
1.4	The ESCC Component Number and Component Type Variants	5
1.4.1	The ESCC Component Number	5
1.4.2	Component Type Variants	5
1.5	Maximum Ratings	5
1.6	Handling Precautions	6
1.7	Physical Dimensions and Terminal Identification	7
1.7.1	Axial Lead Package	7
1.7.2	Leadless Chip Carrier Package (LCC2B) - 2 Terminal	8
1.7.3	Metal Electrode Face Package (MELF) - 2 Terminal	9
1.8	Functional Diagram	9
1.9	Materials and Finishes	9
<u>2.</u>	<u>REQUIREMENTS</u>	<u>10</u>
2.1	General	10
2.1.1	Deviations from the Generic Specification	10
2.1.1.1	Deviations from Special In-Process Controls (Chart F2)	10
2.1.1.2	Deviations from Screening Tests (Chart F3)	10
2.1.1.3	Deviations from Qualification and Periodic Tests (Chart F4)	10
2.2	Marking	10
2.3	Terminal Strength	11
2.4	Electrical Measurements at Room, High and Low Temperatures	11
2.4.1	Room Temperature Electrical Measurements	11
2.4.2	High and Low Temperatures Electrical Measurements	12
2.4.3	Notes to Electrical Measurement Tables	13
2.5	Parameter Drift Values	13
2.6	Intermediate and End-Point Electrical Measurements	14
2.7	High Temperature Reverse Bias Burn-in Conditions	14
2.8	Power Burn-in Conditions	15
2.9	Operating Life Conditions	15
APPENDIX 'A'		17

1. GENERAL

1.1 SCOPE

This specification details the ratings, physical and electrical characteristics and test and inspection data for the component type variants and/or the range of components specified below. It supplements the requirements of, and shall be read in conjunction with, the ESCC Generic Specification listed under Applicable Documents.

1.2 APPLICABLE DOCUMENTS

The following documents form part of this specification and shall be read in conjunction with it:

- (a) ESCC Generic Specification No. 5000
- (b) MIL-STD-750, Test Methods and Procedures for Semiconductor Devices

1.3 TERMS, DEFINITIONS, ABBREVIATIONS, SYMBOLS AND UNITS

For the purpose of this specification, the terms, definitions, abbreviations, symbols and units specified in ESCC Basic Specification No. 21300 shall apply.

1.4 THE ESCC COMPONENT NUMBER AND COMPONENT TYPE VARIANTS

1.4.1 The ESCC Component Number

The ESCC Component Number shall be constituted as follows:

Example: 510602101

- Detail Specification Reference: 5106021
- Component Type Variant Number: 01 (as required)

1.4.2 Component Type Variants

The component type variants applicable to this specification are as follows:

Variant Number	Based on Type	Case	Terminal Material and/or Finish	Weight max g
01	1N5819-1	Axial Lead	L3 or L4	0.4
02	1N5819U	LCC2B	2	0.18
03	1N5819U	LCC2B	4	0.18
04	1N5819UR-1	MELF	L3 or L4	0.4

The terminal material and/or finish shall be in accordance with the requirements of ESCC Basic Specification No. 23500.

1.5 MAXIMUM RATINGS

The maximum ratings shall not be exceeded at any time during use or storage.

Maximum ratings shall only be exceeded during testing to the extent specified in this specification and when stipulated in Test Methods and Procedures of the ESCC Generic Specification.

Characteristics	Symbols	Maximum Ratings	Unit	Remarks
Forward Surge Current	I_{FSM}	25	A	Notes 1, 2
Working Peak Reverse Voltage	V_{RWM}	45	V	
Average Output Rectified Current	I_O	1	A	Note 3
Critical Rate of Rise of Reverse Voltage	dV/dt	10000	V/ μ s	
Operating Temperature Range Variants 01, 04 Variants 02, 03	T_{op}	-65 to +125 -55 to +150	$^{\circ}$ C	T_{amb} , Note 4 T_{case} , Note 4
Junction Temperature Variants 01, 04 Variants 02, 03	T_j	+125 +150	$^{\circ}$ C	
Storage Temperature Range	T_{stg}	-65 to +150	$^{\circ}$ C	Note 4
Soldering Temperature Variants 01, 04 Variants 02, 03	T_{sol}	240 245	$^{\circ}$ C	Note 5
Thermal Resistance, Variant 01 Variants 02, 03 Variant 04	R_{th}	70 16 40	$^{\circ}$ C/W	Note 6

NOTES:

- Sinusoidal pulse of 8.3ms duration for Variants 01 and 04 and 10ms for Variants 02 and 03.
- At $T_{amb} \leq +25^{\circ}$ C.
- For Variant 01: At $T_{lead} \geq +55^{\circ}$ C, derate linearly to 0A at $+125^{\circ}$ C, where T_{lead} is measured on the lead 9.5mm from the body.
For Variants 02, 03: At $T_{case} \geq +142^{\circ}$ C, derate linearly to 0A at $+150^{\circ}$ C.
For Variant 04: At $T_{lead} \geq +55^{\circ}$ C, derate linearly to 0A at $+125^{\circ}$ C, where T_{lead} is measured at the body terminal (T_{lead} at 0mm).
- For Variants 01, 03, 04 with hot solder dip or tin-lead plating terminal finish, all testing performed at $T_{amb} > +125^{\circ}$ C shall be carried out in a 100% inert atmosphere.
- For Variant 01: Duration 10s maximum at a distance of not less than 1.5mm from the device body and the same package shall not be resoldered until 3 minutes have elapsed.
For Variants 02 to 04: Duration 5s maximum and the same package shall not be resoldered until 3 minutes have elapsed.
- For Variant 01: $R_{th(j-l)}$ specified on the lead 9.5mm from the body (T_{lead}).
For Variants 02, 03: $R_{th(j-c)}$ specified at the body terminal (T_{case}).
For Variant 04: $R_{th(j-l)}$ specified at the body terminal (T_{lead} at 0mm).

1.6 **HANDLING PRECAUTIONS**

These devices are susceptible to damage by electrostatic discharge. Therefore, suitable precautions shall be employed for protection during all phases of manufacture, testing, packaging, shipment and any

handling.

Variants 01 and 04 are categorised as Class 2 per ESCC Basic Specification No. 23800 with a Minimum Critical Path Failure Voltage of 2000 Volts.

Variants 02 and 03 are categorised as Class 3 per ESCC Basic Specification No. 23800 with a Minimum Critical Path Failure Voltage of 8000 Volts.

1.7 PHYSICAL DIMENSIONS AND TERMINAL IDENTIFICATION

1.7.1 Axial Lead Package

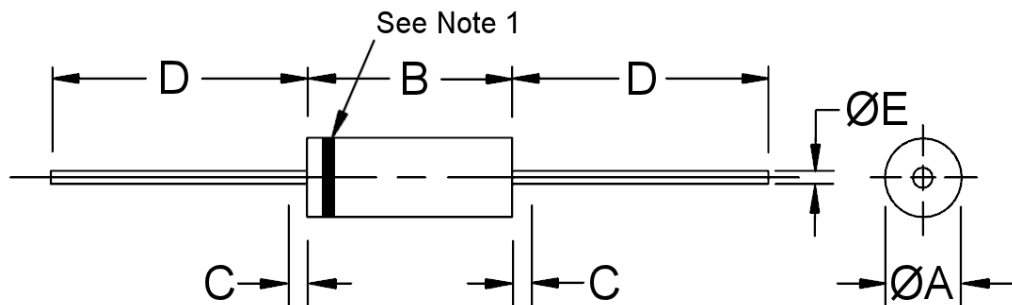

Symbols	Dimensions mm		Notes
	Min	Max	
ØA	2.03	2.72	2
B	4.06	5.21	2
C	-	1.27	3
D	25.4	-	
ØE	0.71	0.86	

NOTES:

1. Terminal identification: The cathode end shall be marked with a contrasting coloured band.
2. Package contour optional within cylinder of diameter ØA and length B. Slugs, if any, shall not be included within this cylinder, but shall not be subject to the minimum limit of ØA.
3. Lead diameter not controlled in this zone to allow for flash, lead finish build-up, and minor irregularities other than slugs.

1.7.2 Leadless Chip Carrier Package (LCC2B) - 2 Terminal

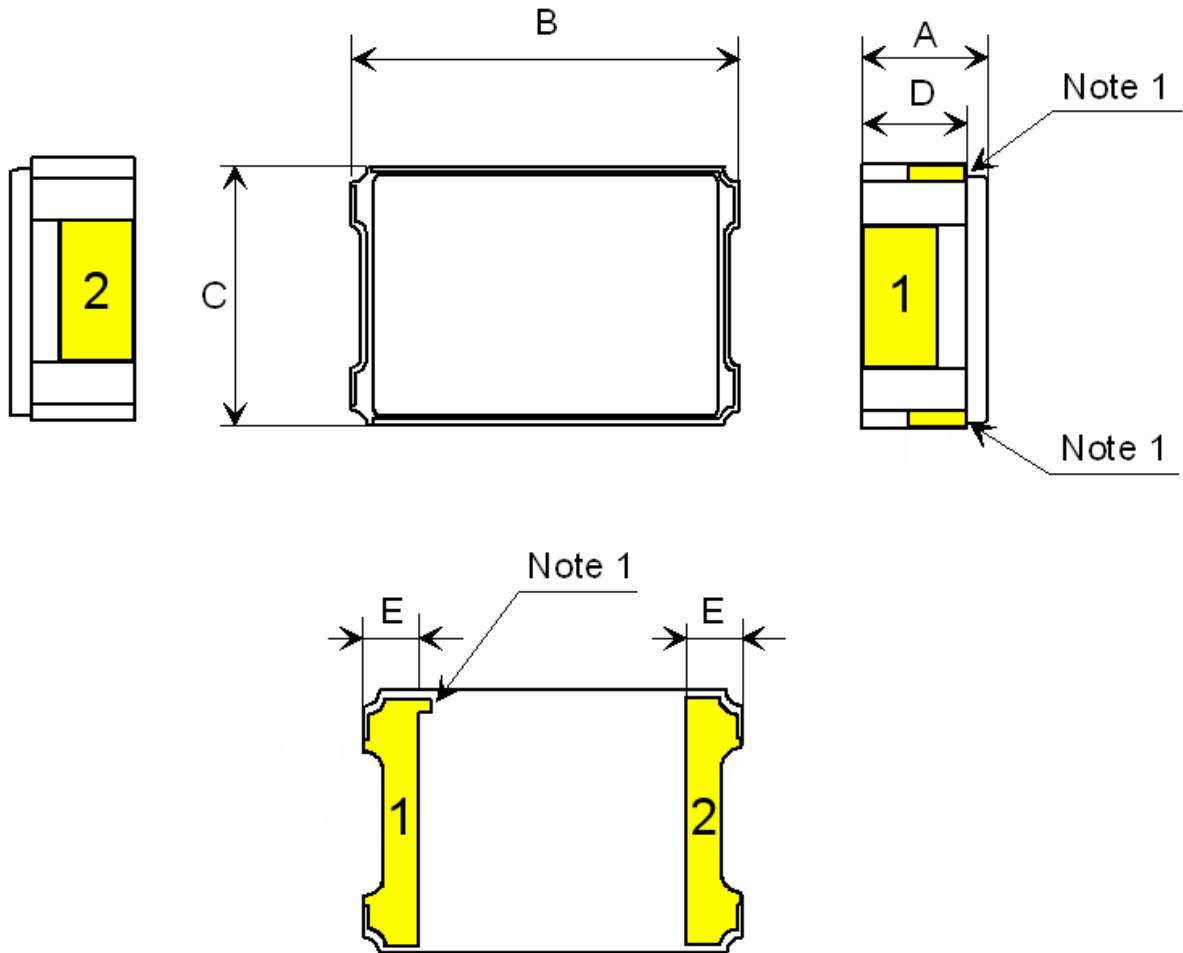

Symbols	Dimensions mm		Notes
	Min	Max	
A	2.04	2.42	2
B	5.27	5.6	
C	3.49	3.76	
D	1.71	2.09	
E	0.48	0.71	

NOTES:

1. Terminal identification: The anode is identified by metallisation in the two castellations and by the index mark on the bottom metallisation.
2. For Variant 03 dimension limits apply prior to solder coating of terminals.

1.7.3 Metal Electrode Face Package (MELF) - 2 Terminal

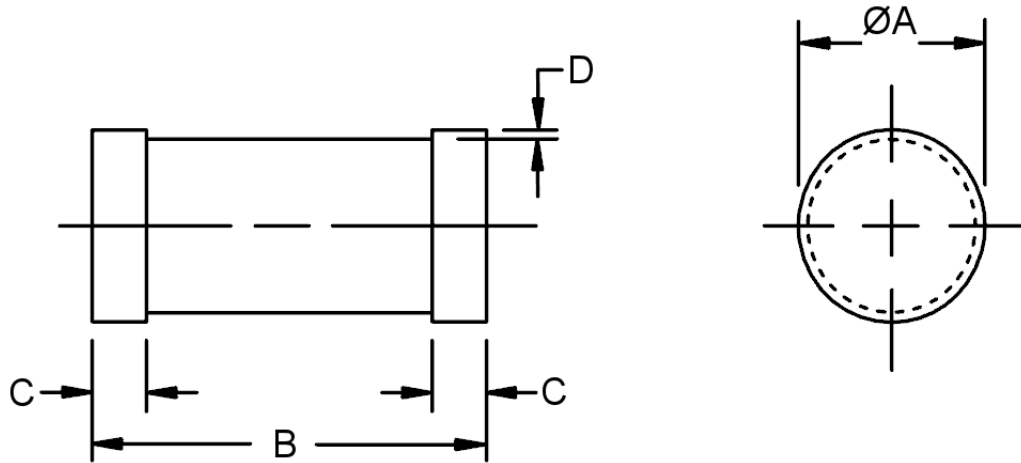

Symbols	Dimensions (mm)		Notes
	Min	Max	
ØA	2.39	2.76	2
B	4.8	5.21	2
C	0.41	0.56	2
D	0.03	-	3

NOTES:

1. Terminal identification: The cathode end shall be marked with either a contrasting coloured band, three dots spaced equally, or a colour dot on the face of the end tab.
2. Dimension limits apply prior to solder coating of terminals.
3. Minimum clearance of glass body to mounting surface on all orientations.

1.8 FUNCTIONAL DIAGRAM

Terminal 1: Anode
Terminal 2: Cathode



NOTES:

1. For LCC2B, the lid is not connected to any terminal.

1.9 MATERIALS AND FINISHES

Materials and finishes shall be as follows:

- a) Case

For Variants 01, 04 the case shall be hermetically sealed and have a glass body.

For Variants 02, 03 the case shall be hermetically sealed and have an Aluminium Nitride body with a Kovar lid.

- b) Terminal Material and/or Finish
As specified in Component Type Variants.

2. **REQUIREMENTS**

2.1 **GENERAL**

The complete requirements for procurement of the components specified herein are as stated in this specification and the ESCC Generic Specification. Permitted deviations from the Generic Specification, applicable to this specification only, are listed below.

Permitted deviations from the Generic Specification and this Detail Specification, formally agreed with specific Manufacturers on the basis that the alternative requirements are equivalent to the ESCC requirement and do not affect the component's reliability, are listed in the appendices attached to this specification.

2.1.1 **Deviations from the Generic Specification**

2.1.1.1 *Deviations from Special In-Process Controls (Chart F2)*

- (a) Bond Strength: Not applicable for Variants 01, 04
- (b) Die Shear: For Variants 01, 04 only, Die Shear shall be replaced by Decap Internal Visual Inspection Design Verification in accordance with MIL-STD-750 Method 2075, to be performed on a sample of 6 components selected at random from the lot.
Verification of metallurgical bonding shall be performed and documented. Photographs with a scale or magnification identifier shall be taken and retained.
In the event of any failure the lot shall be rejected.

2.1.1.2 *Deviations from Screening Tests (Chart F3)*

- (a) Particle Impact Noise Detection: Not applicable for Variants 01, 04.
- (b) Seal, Fine Leak: Not applicable for Variants 01, 04.

2.1.1.3 *Deviations from Qualification and Periodic Tests (Chart F4)*

- (a) Bond Strength: Not applicable for Variants 01, 04.
- (b) Die Shear: For Variants 01, 04 only, Die Shear shall be replaced by Decap Internal Visual Inspection Design Verification in accordance with MIL-STD-750 Method 2075.
Verification of metallurgical bonding shall be performed and documented. Photographs with a scale or magnification identifier shall be taken and retained.
- (c) Seal, Fine Leak: Not applicable for Variants 01, 04.

2.2 **MARKING**

The marking shall be in accordance with the requirements of ESCC Basic Specification No. 21700 and as follows.

The information to be marked on the component shall be:

- (a) Terminal Identification.
- (b) The ESCC qualified components symbol (for ESCC qualified components only).
- (c) The ESCC Component Number.
- (d) Traceability information.

2.3 TERMINAL STRENGTH

The test conditions for Terminal Strength, tested as specified in the ESCC Generic Specification, shall be as follows:

- For Variants 01, 04, Test Condition A with applied force 10N and duration 10s.
- For Variants 02, 03, as specified in the ESCC Generic Specification.

2.4 ELECTRICAL MEASUREMENTS AT ROOM, HIGH AND LOW TEMPERATURES

Electrical measurements shall be performed at room, high and low temperatures. Consolidated notes are given after the tables.

2.4.1 Room Temperature Electrical Measurements

The measurements shall be performed at $T_{amb}=+22 \pm 3^{\circ}C$.

Characteristics	Symbols	MIL-STD-750 Test Method	Test Conditions	Limits		Units
				Min	Max	
Forward Voltage	V_{F1}	4011	Pulse Method $I_F=0.1A$, Note 1 Variants 01, 04 Variants 02, 03	-	0.34 0.35	V
	V_{F2}	4011	Pulse Method $I_F=1A$, Note 1	-	0.49	V
	V_{F3}	4011	Pulse Method $I_F=3.1A$, Note 1	-	0.8	V
Reverse Current 1	I_{R1}	4016	DC Method $V_R=45V$ Variants 01, 04 Variants 02, 03	-	50 20	μA
Reverse Current 2	I_{R2}	4016	DC Method $V_R=40V$ Variants 02, 03 only	-	15	μA
Capacitance	C	4001	$V_R=5V$ $V_{sig}=15mV$ (p-p)max $f = 1MHz$	-	70	pF

Characteristics	Symbols	MIL-STD-750 Test Method	Test Conditions	Limits		Units
				Min	Max	
Thermal Impedance, Junction to Reference Point	$Z_{th(j-x)}$	3101	$t_{MD} = 70\mu s$ max Note 2 Variants 01, 04 only	(Calculate ΔV_F , see Note 3)		$^{\circ}C/W$
Thermal Impedance, Junction to Case	$Z_{th(j-c)}$	3101	$I_H = 1$ to 10A $t_H = 50ms$ $I_M = 50mA$ $t_{MD} = 100\mu s$ Note 2 Variants 02, 03 only	(Calculate ΔV_F , see Note 3)		$^{\circ}C/W$

2.4.2 High and Low Temperatures Electrical Measurements

Characteristics	Symbols	MIL-STD-750 Test Method	Test Conditions Note 4	Limits		Units
				Min	Max	
Forward Voltage 2	V_{F2}	4011	$T_{amb} = +100(+0 -5)^{\circ}C$ Pulse Method $I_F = 1A$, Note 1	-	0.45	V
			$T_{amb} = -55(+5 -0)^{\circ}C$ Pulse Method $I_F = 1A$, Note 1	-	0.65	V
Reverse Current 1	I_{R1}	4016	$T_{amb} = +100(+0 -5)^{\circ}C$ DC Method Pulsed Note 1 $V_R = 45V$ Variants 01, 04 Variants 02, 03	-	5 3.5	mA
			$T_{amb} = -55(+5 -0)^{\circ}C$ DC Method Pulsed Note 1 $V_R = 45V$ Variants 02, 03 only	-	20	μA
Reverse Current 2	I_{R2}	4016	$T_{amb} = +100(+0 -5)^{\circ}C$ DC Method Pulsed Note 1 $V_R = 40V$ Variants 01, 04 Variants 02, 03	-	4.5 3	mA
			$T_{amb} = -55(+5 -0)^{\circ}C$ DC Method Pulsed Note 1 $V_R = 40V$ Variants 02, 03 only	-	10	μA

Characteristics	Symbols	MIL-STD-750 Test Method	Test Conditions Note 4	Limits		Units
				Min	Max	
Reverse Current 3	I_{R3}	4016	$T_{amb}=+100(+0 -5)^{\circ}C$ DC Method Pulsed Note 1 $V_R = 35V$ Variants 01, 04 Variants 02, 03	- -	4 2.5	mA
Reverse Current 4	I_{R4}	4016	$T_{amb}=+100(+0 -5)^{\circ}C$ DC Method Pulsed Note 1 $V_R = 24V$ Variants 01, 04 Variants 02, 03	- -	3.5 1.6	mA
Reverse Current 5	I_{R5}	4016	$T_{amb}=+100(+0 -5)^{\circ}C$ DC Method Pulsed Note 1 $V_R = 12V$ Variants 01, 04 Variants 02, 03	- -	2.5 1.2	mA
Reverse Current 6	I_{R6}	4016	$T_{amb}=+100(+0 -5)^{\circ}C$ DC Method Pulsed Note 1 $V_R = 6V$ Variants 01, 04 Variants 02, 03	- -	2 1	mA

2.4.3 Notes to Electrical Measurement Tables

1. For Variants 01, 04 Pulse Width $\leq 10ms$, Duty Cycle $\leq 2\%$.
For Variants 02, 03 Pulse Width $\leq 680\mu s$, Duty Cycle $\leq 2\%$.
2. Performed only during Screening Tests Parameter Drift Values (Initial Measurements), go-no-go.
3. The limits for ΔV_F shall be defined by the Manufacturer on every lot in accordance with MIL-STD-750 Method 3101 and shall guarantee the R_{th} limits specified in Maximum Ratings.
4. Read and record measurements shall be performed on a sample of 5 components with 0 failures allowed. Alternatively a 100% inspection may be performed.

2.5 PARAMETER DRIFT VALUES

Unless otherwise specified, the measurements shall be performed at $T_{amb}=+22 \pm 3^{\circ}C$.

The test methods and test conditions shall be as per the corresponding test defined in Room Temperature Electrical Measurements.

The drift values (Δ) shall not be exceeded for each characteristic specified. The corresponding absolute limit values for each characteristic shall not be exceeded.

Characteristics	Symbols	Limits			Units
		Drift Value Δ	Absolute		
			Min	Max	
Forward Voltage 2 Variants 01, 04 Variants 02, 03	V_{F2}	± 0.05 ± 0.02	- -	0.49 0.49	V
Reverse Current 1 Variants 01, 04 Variants 02, 03	I_{R1}	± 5 or (1) $\pm 100\%$	- -	50 20	μA

NOTES:

1. Whichever is the greater referred to the initial value.

2.6

INTERMEDIATE AND END-POINT ELECTRICAL MEASUREMENTS

Unless otherwise specified, the measurements shall be performed at $T_{amb} = +22 \pm 3^{\circ}C$.

The test methods and test conditions shall be as per the corresponding test defined in Room Temperature Electrical Measurements.

Characteristics	Symbols	Limits		Units
		Min	Max	
Forward Voltage 1 (Variants 01, 04 only)	V_{F1}	-	0.34	V
Forward Voltage 2	V_{F2}	-	0.49	V
Forward Voltage 3 (Variants 01, 04 only)	V_{F3}	-	0.8	V
Reverse Current 1 Variants 01, 04 Variants 02, 03	I_{R1}	- -	50 20	μA

2.7

HIGH TEMPERATURE REVERSE BIAS BURN-IN CONDITIONS

For Variants 01, 04

Characteristics	Symbols	Limits	Units
Ambient Temperature	T_{amb}	+110 (+0 -5)	$^{\circ}C$
Junction Temperature	T_j	+115 maximum (Note 1)	$^{\circ}C$
Reverse Voltage	V_R	45 (Note 2)	Vpk
Duration	t	≥ 48	hours

For Variants 02, 03

Characteristics	Symbols	Test Conditions	Units
Ambient Temperature	T_{amb}	+80 ± 3	°C
Reverse Voltage	V_R	45 (Note 3)	V
Duration	t	96	hours

NOTES:

1. Junction temperature shall be controlled to ensure thermal runaway is avoided.
2. V_R = half sine wave, $f \leq 100\text{Hz}$.
3. V_R = rectangular wave, $f = 50\text{Hz}$, duty cycle = 90%.

2.8 POWER BURN-IN CONDITIONS

For Variants 01, 04

Characteristics	Symbols	Test Conditions	Units
Ambient Temperature	T_{amb}	Note 1	°C
Junction Temperature	T_j	+100 minimum	°C
Forward Current	I_F	1 minimum (Note 1)	A

For Variants 02, 03

Characteristics	Symbols	Test Conditions	Units
Ambient Temperature	T_{amb}	+22 ± 3	°C
Junction Temperature	T_j	+150 (+0 -5)	°C
Average Output Rectified Current	I_O	Note 2	A

NOTES:

1. I_F and/or T_{amb} may be adjusted, within the given limit range, to attain the specified junction temperature.
2. I_O may be adjusted, within the given limit range, to attain the specified junction temperature.

2.9 OPERATING LIFE CONDITIONS

For Variants 01, 04

Characteristics	Symbols	Test Conditions	Units
Ambient Temperature	T_{amb}	Note 1	°C
Junction Temperature	T_j	+125 minimum	°C
Forward Current	I_F	1 minimum (Note 1)	A

For Variants 02, 03

Characteristics	Symbols	Test Conditions	Units
Ambient Temperature	T_{amb}	+22 ± 3	°C
Junction Temperature	T_j	+150 (+0 -5)	°C
Average Output Rectified Current	I_O	Note 2	A

NOTES:

1. I_F and/or T_{amb} may be adjusted, within the given limit range, to attain the specified junction temperature.
2. I_O may be adjusted, within the given limit range, to attain the specified junction temperature.

APPENDIX 'A'

AGREED DEVIATIONS FOR STMICROELECTRONICS (F)

ITEMS AFFECTED	DESCRIPTION OF DEVIATIONS
Deviations from Production Control- Chart F2	Special In-process Control Internal Visual Inspection. Wedge bonds equal to 1.1 wire diameters are acceptable for bonding with a V-Groove tool.
	Special In-process Control Internal Visual Inspection. For CCP packages the criteria specified for voids in the fillet and minimum die mounting material around the visible die perimeter for die mounting defects may be omitted providing that a radiographic inspection to verify the die-attach process is performed on a sample basis in accordance with STMicroelectronics procedure 7050651.
Deviations from Screening Tests - Chart F3	Solderability is not applicable unless specifically stipulated in the Purchase Order.
Room Temperature Electrical Measurements	All AC characteristics (C) may be considered guaranteed but not tested if successful pilot lot testing has been performed in accordance with STMicroelectronics procedure 7188211 on the wafer lot, which includes AC characteristic measurements per the Detail Specification. A summary of the pilot lot testing shall be provided if required by the Purchase Order.