



Pages 1 to 14

**RESISTORS, HEATERS, FLEXIBLE
SINGLE AND DOUBLE LAYER**

ESCC Detail Specification No. 4009/002

| | |
|---------|------------|
| Issue 6 | March 2010 |
|---------|------------|



Document Custodian: European Space Agency - see <https://escies.org>

LEGAL DISCLAIMER AND COPYRIGHT

European Space Agency, Copyright © 2010. All rights reserved.

The European Space Agency disclaims any liability or responsibility, to any person or entity, with respect to any loss or damage caused, or alleged to be caused, directly or indirectly by the use and application of this ESCC publication.

This publication, without the prior permission of the European Space Agency and provided that it is not used for a commercial purpose, may be:

- copied in whole, in any medium, without alteration or modification.
- copied in part, in any medium, provided that the ESCC document identification, comprising the ESCC symbol, document number and document issue, is removed.

DOCUMENTATION CHANGE NOTICE

(Refer to <https://escies.org> for ESCC DCR content)

| DCR No. | CHANGE DESCRIPTION |
|---------|---|
| 584 | Specification up issued to incorporate technical changes per DCR. |

TABLE OF CONTENTS

| | | |
|-----------|--|----------|
| 1. | <u>GENERAL</u> | 5 |
| 1.1 | Scope | 5 |
| 1.2 | Applicable Documents | 5 |
| 1.3 | Terms, Definitions, Abbreviations, Symbols and Units | 5 |
| 1.4 | The ESCC Component Number and Component Type Variants | 5 |
| 1.4.1 | The ESCC Component Number | 5 |
| 1.4.2 | Component Type Variants and Range of Components | 5 |
| 1.4.3 | Manufacturer Specific Heater Identification | 7 |
| 1.5 | Maximum Ratings | 7 |
| 1.6 | Physical Dimensions and Heater Outline | 8 |
| 1.6.1 | Heater Thickness | 9 |
| 1.7 | Materials and Finishes | 9 |
| 1.7.1 | Heater Resistive Element | 9 |
| 1.7.2 | Protective Coating | 9 |
| 1.7.3 | Terminal Leads | 9 |
| 2. | <u>REQUIREMENTS</u> | 9 |
| 2.1 | General | 9 |
| 2.1.1 | Deviations from the Generic Specification | 9 |
| 2.1.1.1 | Deviations from Screening Tests - Chart F3 | 9 |
| 2.2 | Marking | 10 |
| 2.3 | Robustness of Terminations | 10 |
| 2.4 | Electrical Measurements at Room, High and Low Temperatures | 10 |
| 2.4.1 | Room Temperature Electrical Measurements | 10 |
| 2.4.2 | High and Low Temperatures Electrical Measurements | 11 |
| 2.5 | Intermediate and End-Point Electrical Measurements | 11 |
| 2.6 | Burn-in Conditions | 13 |
| 2.7 | Operating Life Conditions | 13 |
| | APPENDIX 'A' | 14 |

1. GENERAL

1.1 SCOPE

This specification details the ratings, physical and electrical characteristics and test and inspection data for the component type variants and/or the range of components specified below. It supplements the requirements of, and shall be read in conjunction with, the ESCC Generic Specification listed under Applicable Documents.

1.2 APPLICABLE DOCUMENTS

The following documents form part of this specification and shall be read in conjunction with it:

- (a) ESCC Generic Specification No. 4009.
- (b) MIL-P-46112: Military Specification for Polyimide Plastic Sheet and Strip.
- (c) ASTM-D5213: Standard Specification for Polymeric Resin Film for Electrical Insulation and Dielectric Applications.

1.3 TERMS, DEFINITIONS, ABBREVIATIONS, SYMBOLS AND UNITS

For the purpose of this specification, the terms, definitions, abbreviations, symbols and units specified in ESCC Basic Specification No. 21300 shall apply.

1.4 THE ESCC COMPONENT NUMBER AND COMPONENT TYPE VARIANTS

1.4.1 The ESCC Component Number

The ESCC Component Number shall be constituted as follows:

Example: 400900201A1234

- Detail Specification Reference: 4009002
- Component Type Variant Number: 01 (as required)
- Manufacturer Specific Heater Identification: A1234 (as applicable) where
 - A: First letter of the applicable Manufacturer's name
 - 1234: A unique 4 digit number, sequentially allocated by the applicable Manufacturer to a specific heater design.

1.4.2 Component Type Variants and Range of Components

The component type variants and range of components applicable to this specification are as follows:

| Variant (Note 1) | Terminal Leads | | Resistance Range Rn (Ω) | Resistance Tolerance (±%) | Heating Area S (cm ²) | Resistance Density (Ω/cm ²) | Temperature Coefficient (10 ⁻⁶ /°C) | Weight Max (g) |
|---------------------|------------------------|---------------------------|----------------------------------|---------------------------------|--|---|--|----------------------|
| | Wire Gauge (AWG) | Configuration (Note 2) | | | | | | |
| 01, 25 | 20 | Straight | 1 to 5000 | 2, 3, 5, 10 | 1.6 to 1300 | 0.1 to 200 | 175 | Note 3 |
| 02, 26 | 22 | Straight | 1 to 5000 | 2, 3, 5, 10 | 1.6 to 1300 | 0.1 to 200 | 175 | Note 3 |
| 03, 27 | 24 | Straight | 1 to 5000 | 2, 3, 5, 10 | 1.6 to 1300 | 0.1 to 200 | 175 | Note 3 |
| 04, 28 | 26 | Straight | 1 to 5000 | 2, 3, 5, 10 | 1.6 to 1300 | 0.1 to 200 | 175 | Note 3 |
| 05, 29 | 28 | Straight | 1 to 5000 | 2, 3, 5, 10 | 1.6 to 1300 | 0.1 to 200 | 175 | Note 3 |
| 06, 30 | 30 | Straight | 1 to 5000 | 2, 3, 5, 10 | 1.6 to 1300 | 0.1 to 200 | 175 | Note 3 |
| 07, 31 | 20 | UTP | 1 to 5000 | 2, 3, 5, 10 | 1.6 to 1300 | 0.1 to 200 | 175 | Note 3 |
| 08, 32 | 22 | UTP | 1 to 5000 | 2, 3, 5, 10 | 1.6 to 1300 | 0.1 to 200 | 175 | Note 3 |
| 09, 33 | 24 | UTP | 1 to 5000 | 2, 3, 5, 10 | 1.6 to 1300 | 0.1 to 200 | 175 | Note 3 |
| 10, 34 | 26 | UTP | 1 to 5000 | 2, 3, 5, 10 | 1.6 to 1300 | 0.1 to 200 | 175 | Note 3 |
| 11, 35 | 28 | UTP | 1 to 5000 | 2, 3, 5, 10 | 1.6 to 1300 | 0.1 to 200 | 175 | Note 3 |
| 12, 36 | 30 | UTP | 1 to 5000 | 2, 3, 5, 10 | 1.6 to 1300 | 0.1 to 200 | 175 | Note 3 |
| 13, 37 | 20 | JTP | 1 to 5000 | 2, 3, 5, 10 | 1.6 to 1300 | 0.1 to 200 | 175 | Note 3 |
| 14, 38 | 22 | JTP | 1 to 5000 | 2, 3, 5, 10 | 1.6 to 1300 | 0.1 to 200 | 175 | Note 3 |
| 15, 39 | 24 | JTP | 1 to 5000 | 2, 3, 5, 10 | 1.6 to 1300 | 0.1 to 200 | 175 | Note 3 |
| 16, 40 | 26 | JTP | 1 to 5000 | 2, 3, 5, 10 | 1.6 to 1300 | 0.1 to 200 | 175 | Note 3 |
| 17, 41 | 28 | JTP | 1 to 5000 | 2, 3, 5, 10 | 1.6 to 1300 | 0.1 to 200 | 175 | Note 3 |
| 18, 42 | 30 | JTP | 1 to 5000 | 2, 3, 5, 10 | 1.6 to 1300 | 0.1 to 200 | 175 | Note 3 |
| 19, 43 | 20 | STP | 1 to 5000 | 2, 3, 5, 10 | 1.6 to 1300 | 0.1 to 200 | 175 | Note 3 |
| 20, 44 | 22 | STP | 1 to 5000 | 2, 3, 5, 10 | 1.6 to 1300 | 0.1 to 200 | 175 | Note 3 |
| 21, 45 | 24 | STP | 1 to 5000 | 2, 3, 5, 10 | 1.6 to 1300 | 0.1 to 200 | 175 | Note 3 |
| 22, 46 | 26 | STP | 1 to 5000 | 2, 3, 5, 10 | 1.6 to 1300 | 0.1 to 200 | 175 | Note 3 |
| 23, 47 | 28 | STP | 1 to 5000 | 2, 3, 5, 10 | 1.6 to 1300 | 0.1 to 200 | 175 | Note 3 |
| 24, 48 | 30 | STP | 1 to 5000 | 2, 3, 5, 10 | 1.6 to 1300 | 0.1 to 200 | 175 | Note 3 |

NOTES:

1. Variants 01 to 24 are single layer heaters.
Variants 25 to 48 are double layer heaters.
2. UTP = Unjacketed Twisted Pair, JTP = Jacketed Twisted Pair, STP = Shielded Twisted Pair.
3. The maximum weight of the heaters, excluding the weight of the terminal leads, shall be:
Single layer heaters: 50mg/cm²
Double layer heaters: 75mg/cm²

The weight of the terminal leads shall be as specified in the applicable wire ESCC Detail Specification.

1.4.3 Manufacturer Specific Heater Identification

A Heater Design Drawing shall be produced by the Manufacturer after negotiation with the Orderer and shall be held under configuration control by the Manufacturer who will allocate a unique Manufacturer Specific Heater Identification sequentially when a request for a heater is received.

Each Heater Design Drawing shall include the following information:

- (a) The heater outline and dimensions as required by Physical Dimensions herein. This shall include details of the terminal leads configurations and the angle of exit of each terminal lead with respect to the heater body.
- (b) The ESCC Component Number for the heater, including the Manufacturer Specific Heater Identification.
- (c) The terminal leads' ESCC Detail Specification and Component Number.
- (d) The heater electrical information as follows:
 - Resistance value R_n and tolerance by circuit at $T_{amb} = +22 \pm 3^\circ C$.
 - Maximum rated power in still air at $T_{amb} = +25^\circ C$.
- (e) Track width and spacing with tolerances.
- (f) Cover material (if fitted).
- (g) Pressure sensitive tape (if fitted).
- (h) Dimensions of pre-form, if required.

1.5 MAXIMUM RATINGS

The maximum ratings shall not be exceeded at any time during use or storage.

Maximum ratings shall only be exceeded during testing to the extent specified in this specification and when stipulated in Test Methods and Procedures of the ESCC Generic Specification.

| Characteristics | Symbols | Maximum Ratings | Units | Remarks |
|-----------------------------|-----------|--------------------------------|-------------------|---------------------|
| Rated Power Density | P_n | 0.54 | W/cm ² | Notes 1, 2, 3, 4 |
| Operating Temperature Range | T_{op} | -65 to +200 | °C | T_{amb} Note 3 |
| Storage Temperature Range | T_{stg} | -65 to +200 | °C | - |
| Rated Voltage | U_R | $\sqrt{P_n \cdot R_n \cdot S}$ | V | Notes 2, 3, 5 |

NOTES:

1. With heater suspended in still air at $T_{amb} = +25^\circ C$.
2. Actual rated power shall be specified in the applicable Heater Design Drawing. It shall be determined from the Heating Area (S) in cm².
3. Rated Power Density shall be derated against temperature and Heating Area as follows:
 - (a) $P_n = 0.54 W/cm^2$ for $T_{amb} \leq +25^\circ C$. Derate to $0 W/cm^2$ at $0.00308 W/cm^2 / ^\circ C$ for $+25^\circ C < T_{amb} \leq +200^\circ C$.
 - (b) $P_n = 0.54 W/cm^2$ for $1.6 cm^2 \leq \text{Heating Area (S)} \leq 300 cm^2$. Derate to $0.3 W/cm^2$ at

$0.00024W/cm^2/cm^2$ for $300cm^2 < \text{Heating Area (S)} \leq 1300cm^2$.

4. The following design rule shall be applied:

$$\frac{\text{Area of Heater Resistive Element}}{\text{Heating Area (S)}} = 50 \pm 10\%$$

5. R_n is the nominal resistance.

1.6 **PHYSICAL DIMENSIONS AND HEATER OUTLINE**

The general physical dimensions and heater layout shall be as follows. The physical dimensions and heater layout applicable to a specific heater will be specified in the Heater Design Drawing held by the Manufacturer.

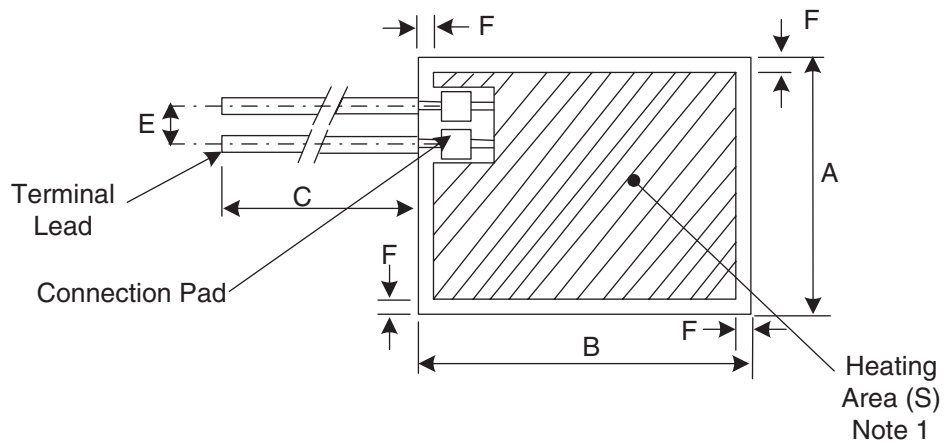

| Symbol | Dimensions mm | | Tolerance ± mm | Remarks |
|--------|---------------|-----|-------------------|------------|
| | Min | Max | | |
| A | 6 | 590 | 0.5 | Note 1 |
| B | 8 | 600 | 0.5 | Note 1 |
| C | 300 | - | Note 2 | - |
| E | 2 | - | Note 3 | Note 4 |
| F | 0.4 | - | - | Notes 5, 6 |

NOTES:

1. The Heating Area is defined as the total area of the heater excluding the peripheral margin and the terminal lead connection area. The acceptable limits of S are specified in Component Type Variants and Range of Components.
2. The tolerance shall be $\pm 10\%$ on the required dimension.
3. The tolerance shall be $\pm 0.5mm$ on the required dimension.
4. Terminal lead spacing shall be measured at the terminal lead connection area. Terminal leads may exit the terminal lead connection area at any angle. The terminal leads may be located on any side of the heater. There may be more than 2 terminal leads (for multiple resistive element and double

layer heaters).

5. Peripheral margin dimension.
6. Perforated holes in the peripheral margin are allowed provided that the distance between the edge of the hole and the heater resistive element or connection pad is equal to, or greater than, dimension F.

1.6.1 Heater Thickness

The maximum thicknesses for single layer and double layer heaters are as follows:

0.2mm maximum for single layer heaters.

0.3mm maximum for double layer heaters.

These maximum limits do not apply over the terminal lead connection area.

1.7 MATERIALS AND FINISHES

1.7.1 Heater Resistive Element

The heater resistive element shall be made of flexible nickel/chromium/iron alloy (76/16/8 Inconel).

1.7.2 Protective Coating

Heater resistive elements and terminal lead connections shall be completely coated with Polyimide Polymer/FEP in accordance with MIL-P-46112 (as superseded by ASTM-D5213).

1.7.3 Terminal Leads

Terminal leads shall be made of multi-strand silver-plated copper in accordance with ESCC Generic Specification No. 3901. The applicable Heater Design Drawing shall specify the wire ESCC Detail Specification and the wire ESCC Component Number. The wire gauge shall be as specified in Component Type Variants and Range of Components herein. Terminal leads shall be electrically welded to the heater resistive element.

2. REQUIREMENTS

2.1 GENERAL

The complete requirements for procurement of the components specified herein are as stated in this specification and the ESCC Generic Specification. Permitted deviations from the Generic Specification, applicable to this specification only, are listed below.

Permitted deviations from the Generic Specification and this Detail Specification, formally agreed with specific Manufacturers on the basis that the alternative requirements are equivalent to the ESCC requirement and do not affect the component's reliability, are listed in the appendices attached to this specification.

2.1.1 Deviations from the Generic Specification

2.1.1.1 *Deviations from Screening Tests - Chart F3*

- (a) For heaters where the Heater Design Drawing requires the application of cover material or pressure sensitive tape the following additional steps shall be performed during Screening Tests:

- (i) An additional 100% External Visual Inspection shall be performed after successful completion of High and Low Temperatures Electrical Measurements.
- (ii) After successful completion of the additional External Visual Inspection the cover material and/or pressure sensitive tape shall be applied.

Note:

For heaters which already have a backing foil applied the additional External Visual Inspection shall not be performed.

- (b) For heaters where the Heater Design Drawing requires pre-forming this shall be performed on successful completion of Screening Tests. The pre-forming operation shall be performed at a temperature not exceeding the maximum storage temperature. An additional External Visual Inspection shall be performed after the pre-forming operation to check for any damage.

2.2 MARKING

The marking shall be in accordance with the requirements of ESCC Basic Specification No. 21700 and as follows.

The information to be marked on the component shall be:

- (a) The ESCC qualified components symbol (for ESCC qualified components only).
- (b) The ESCC Component Number.
- (c) Traceability information.

2.3 ROBUSTNESS OF TERMINATIONS

The test conditions for robustness of terminations, tested as specified in the ESCC Generic Specification, shall be as follows and apply to a single terminal lead at a time.

| | | | | | | |
|----------------------|----|----|----|----|----|-----|
| Wire Gauge (AWG) | 20 | 22 | 24 | 26 | 28 | 30 |
| Pull Strength (N) | 45 | 36 | 22 | 13 | 9 | 4.5 |
| Duration (s) Minimum | 5 | 5 | 5 | 5 | 5 | 5 |

2.4 ELECTRICAL MEASUREMENTS AT ROOM, HIGH AND LOW TEMPERATURES

The measurements shall be performed at room, high and low temperatures.

2.4.1 Room Temperature Electrical Measurements

The measurements shall be performed at $T_{amb}=+22 \pm 3^{\circ}C$.

| Characteristics | Symbols | Test Method and Conditions | Limits | | Units |
|-----------------|---------|--|---|---|----------|
| | | | Min | Max | |
| Resistance | R_A | ESCC No. 4009 ±2% Tolerance ±3% Tolerance ±5% Tolerance ±10% Tolerance | 0.98 Rn 0.97 Rn 0.95 Rn 0.9 Rn | 1.02 Rn 1.03 Rn 1.05 Rn 1.1 Rn | Ω |

| Characteristics | Symbols | Test Method and Conditions | Limits | | Units |
|-------------------------------|---------|---|--------|------------------|-----------------------------------|
| | | | Min | Max | |
| Insulation Resistance | R_I | ESCC No. 4009 | 1000 | - | M Ω |
| Voltage Proof Leakage Current | I_L | ESCC No. 4009 Test Voltage = 500Vrms | - | 2 or (1) 4 | mA μ A/cm ² |

NOTES:

1. Whichever is greater based on the Heating Area.

2.4.2 High and Low Temperatures Electrical Measurements

| Characteristics | Symbols | Test Method and Conditions (Note 1) | Limits | | Units |
|---|---------------------|-------------------------------------|--------|-------|-------|
| | | | Min | Max | |
| Resistance change between -65(+3 -0) ^o C and +22 \pm 3 ^o C | $\Delta R_A/R_A(L)$ | ESCC No. 4009 | 0 | -1.57 | % |
| Resistance change between +200(+0 -3) ^o C and +22 \pm 3 ^o C | $\Delta R_A/R_A(H)$ | ESCC No. 4009 | 0 | +3.17 | % |

NOTES:

1. Measurements shall be performed during Screening Tests on a sample of 3 components. In the event of any failure a 100% inspection shall be performed.

2.5 INTERMEDIATE AND END-POINT ELECTRICAL MEASUREMENTS

Unless otherwise specified, the measurements shall be performed at $T_{amb}=+22 \pm 3^{\circ}C$.

The test methods and test conditions shall be as per the corresponding test defined in Room Temperature Electrical Measurements.

The drift values (Δ) shall not be exceeded for each characteristic where specified. The corresponding absolute limit values for each characteristic shall not be exceeded.

| Test Reference per ESCC No. 4009 | Characteristics | Symbols | Limits | | Units |
|--|---|---------|---|---|----------|
| | | | Min. | Max. | |
| Robustness of Terminations Initial Measurements | Resistance \pm 2% Tolerance \pm 3% Tolerance \pm 5% Tolerance \pm 10% Tolerance | R_A | 0.98 Rn 0.97 Rn 0.95 Rn 0.9 Rn | 1.02 Rn 1.03 Rn 1.05 Rn 1.1 Rn | Ω |

| Test Reference per ESCC No. 4009 | Characteristics | Symbols | Limits | | Units |
|--|---|------------------|---------|------------|--------------------|
| | | | Min. | Max. | |
| Final Measurements | Resistance | R_A | 0.98 Rn | 1.02 Rn | Ω |
| | ±2% Tolerance | | 0.97 Rn | 1.03 Rn | |
| | ±3% Tolerance | | 0.95 Rn | 1.05 Rn | |
| | ±5% Tolerance | | 0.9 Rn | 1.1 Rn | |
| | ±10% Tolerance | | - | ±1 | % |
| | Change in Resistance | $\Delta R_A/R_A$ | | | |
| Climatic Sequence | | | | | |
| Initial Measurements | Resistance | R_A | 0.98 Rn | 1.02 Rn | Ω |
| | ±2% Tolerance | | 0.97 Rn | 1.03 Rn | |
| | ±3% Tolerance | | 0.95 Rn | 1.05 Rn | |
| | ±5% Tolerance | | 0.9 Rn | 1.1 Rn | |
| | ±10% Tolerance | | | | |
| Final Measurements | Resistance | R_A | 0.98 Rn | 1.02 Rn | Ω |
| | ±2% Tolerance | | 0.97 Rn | 1.03 Rn | |
| | ±3% Tolerance | | 0.95 Rn | 1.05 Rn | |
| | ±5% Tolerance | | 0.9 Rn | 1.1 Rn | |
| | ±10% Tolerance | | - | ±2 | % |
| | Change in Resistance | $\Delta R_A/R_A$ | | | |
| | Insulation Resistance | R_I | 1000 | - | M Ω |
| | Voltage Proof Leakage Current (Test Voltage: 500Vrms) | I_L | - | 2 or (1) 4 | mA $\mu A/cm^2$ |
| Operating Life | | | | | |
| Initial Measurements (0 hours) | Resistance | R_A | 0.98 Rn | 1.02 Rn | Ω |
| | ±2% Tolerance | | 0.97 Rn | 1.03 Rn | |
| | ±3% Tolerance | | 0.95 Rn | 1.05 Rn | |
| | ±5% Tolerance | | 0.9 Rn | 1.1 Rn | |
| | ±10% Tolerance | | | | |
| Intermediate Measurements (1000 hours) | Resistance | R_A | 0.98 Rn | 1.02 Rn | Ω |
| | ±2% Tolerance | | 0.97 Rn | 1.03 Rn | |
| | ±3% Tolerance | | 0.95 Rn | 1.05 Rn | |
| | ±5% Tolerance | | 0.9 Rn | 1.1 Rn | |
| | ±10% Tolerance | | - | ±1.4 | % |
| | Change in Resistance | $\Delta R_A/R_A$ | | | |

| Test Reference per ESCC No. 4009 | Characteristics | Symbols | Limits | | Units |
|---|---|------------------|---------------|--------------------|----------|
| | | | Min. | Max. | |
| Final Measurements (2000 hours) | Resistance | R_A | 0.98 Rn | 1.02 Rn | Ω |
| | ±2% Tolerance | | 0.97 Rn | 1.03 Rn | |
| | ±3% Tolerance | | 0.95 Rn | 1.05 Rn | |
| | ±5% Tolerance | | 0.9 Rn | 1.1 Rn | |
| | ±10% Tolerance | | - | ±2 | % |
| | Change in Resistance (related to 0 hours) | $\Delta R_A/R_A$ | - | ±2 | % |
| Insulation Resistance | R_I | 1000 | - | M Ω | |
| Voltage Proof Leakage Current (Test Voltage: 500Vrms) | I_L | - | 2 or (1) 4 | mA $\mu A/cm^2$ | |

NOTES:

1. Whichever is greater based on the Heating Area.

2.6 BURN-IN CONDITIONS

| Characteristics | Symbols | Test Conditions | Units |
|--------------------|-----------|-----------------|-------------------|
| Heater Temperature | T_{HTR} | +200 (Note 1) | $^{\circ}C$ |
| Power Density | Pn | 0.54 (Note 1) | W/cm ² |

NOTES:

1. Voltage shall be applied until either the specified heater temperature or the power density is reached.

2.7 OPERATING LIFE CONDITIONS

The conditions shall be as specified for Burn-in.

APPENDIX 'A'

AGREED DEVIATIONS FOR RICA (I)

| ITEMS AFFECTED | DESCRIPTION OF DEVIATIONS |
|--|---|
| Deviations from the Generic Specification | <p>Qualification and Periodic Tests - Chart F4: The specified period for the Endurance Subgroup shall be 24 months.</p> |
| Deviations from Screening Tests - Chart F3 | <p>Heaters with cover material applied: Where cover material has been applied during the heater lamination process, the deviations specified in Para. 2.1.1.1(a) of this specification are not applicable.</p> <p>Serialisation: A 100% serialisation, performed prior to Screening Tests with subsequent Electrical Measurements at Room, High and Low Temperatures performed read and record, is optional at the Manufacturer's discretion.</p> <p>Para. 8.2, Rapid Change of Temperature: Mounting: Heaters may be mounted using any suitable method. Data Points: Electrical measurements during and after testing are optional at the Manufacturer's discretion.</p> <p>Para. 8.3, Overload: Data Points: Electrical measurements after testing are optional at the Manufacturer's discretion.</p> |