



Pages 1 to 103

**RF COAXIAL CONNECTORS, TYPE SMA,
50 OHMS (FEMALE CONTACT)
ESCC Detail Specification No. 3402/002**

**ISSUE 3
April 2010**



Document Custodian: European Space Agency - see <https://escies.org>



ESCC Detail Specification
No. 3402/002

PAGE i
ISSUE 3

LEGAL DISCLAIMER AND COPYRIGHT

European Space Agency, Copyright © 2010. All rights reserved.

The European Space Agency disclaims any liability or responsibility, to any person or entity, with respect to any loss or damage caused, or alleged to be caused, directly or indirectly by the use and application of this ESCC publication.

This publication, without the prior permission of the European Space Agency and provided that it is not used for a commercial purpose, may be:

- copied in whole in any medium without alteration or modification.
- copied in part, in any medium, provided that the ESCC document identification, comprising the ESCC symbol, document number and document issue, is removed.

DOCUMENTATION CHANGE NOTICE

(Refer to <https://escies.org> for ESCC DCR content)

DCR No.	CHANGE DESCRIPTION
553, 569	Specification upissued to incorporate editorial and technical changes per DCRs.



TABLE OF CONTENTS

	<u>Page</u>
1. <u>GENERAL</u>	5
1.1 Scope	5
1.2 Type Variants	5
1.3 Maximum Ratings	5
1.4 Parameter Derating Information	5
1.5 Physical Dimensions	5
1.6 Standard Test Connector Interface	5
2. <u>APPLICABLE DOCUMENTS</u>	11
3. <u>TERMS, DEFINITIONS, ABBREVIATIONS, SYMBOLS AND UNITS</u>	11
4. <u>REQUIREMENTS</u>	11
4.1 General	11
4.2 Deviations from Generic Specification	11
4.2.1 Deviations from Special In-process Controls	11
4.2.2 Deviations from Final Production Tests	11
4.2.3 Deviations from Burn-in Tests	11
4.2.4 Deviations from Qualification Tests	11
4.2.5 Deviations from Lot Acceptance Tests	11
4.3 Mechanical Requirements	12
4.3.1 Dimension Check	12
4.3.2 Weight	12
4.3.3 Coupling Proof Torque	12
4.3.4 Cable Retention Force	12
4.3.5 Mating and Unmating Forces	12
4.3.6 Endurance	12
4.3.7 Residual Magnetism	12
4.3.8 Contact Engagement and Separation Forces	13
4.3.9 Contact Retention	13
4.4 Materials and Finishes	13
4.4.1 Beryllium Copper Version Gold Plated	14
4.4.2 Stainless Steel Version Electro-passivated	14
4.4.3 Stainless Steel Version Gold Plated	15
4.4.4 Iron Nickel Gold Plated Hermetic Type	16
4.5 Marking	16
4.5.1 General	16
4.5.2 The ESCC Component Number	16
4.5.3 Characteristics	18
4.5.4 Traceability Information	18
4.5.5 Marking of Small Components	18
4.6 Electrical Measurements	18
4.6.1 Electrical Measurements at Room Temperature	18
4.6.2 Electrical Measurements at High and Low Temperatures	18
4.6.3 Circuits for Electrical Measurements	18
4.7 Burn-in Tests	18



	<u>Page</u>
4.8 Environmental and Endurance Tests	19
4.8.1 Measurements and Inspections on Completion of Environmental Tests	19
4.8.2 Measurements and Inspections at Intermediate Points during Endurance Tests	19
4.8.3 Measurements and Inspections on Completion of Endurance Tests	19
4.8.4 Conditions for Operating Life Tests	19
4.8.5 Electrical Circuits for Operating Life Tests	19
4.8.6 Conditions for High Temperature Storage Test	19

TABLES

1(a) Type Variants	6
1(b) Maximum Ratings	7
2 Electrical Measurements at Room Temperature	19
3 Not applicable	N/A
4 Not applicable	N/A
5 Not applicable	N/A
6 Measurements and Inspections on Completion of Environmental and Endurance Tests	20

FIGURES

1 Parameter Derating Information	8
2 Physical Dimensions	9
2(a) Connector Interface - Female Contact	9
2(b) Variants	22
3 Standard Test Connector Interface - Male Contact	10
4 Test Pin Configuration	13

APPENDICES (Applicable to specific Manufacturers only)

None.

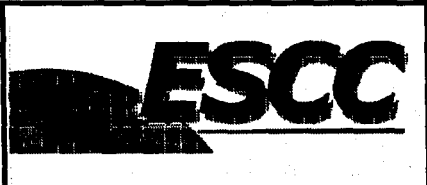

1. GENERAL

1.1 SCOPE

This specification details the ratings, physical and electrical characteristics, test and inspection data for RF Coaxial Connectors, Type SMA, 50 Ohms (Female Contact). It shall be read in conjunction with ESA/SCC Generic Specification No. 3402, the requirements of which are supplemented herein.

1.2 TYPE VARIANTS

A list of the type variants of the connectors specified herein, which are also covered by this specification, is given in Table 1(a).

For each type variant, the full electrical and physical characteristics are given in individual Figures 2(b) at the end of this specification.

1.3 MAXIMUM RATINGS

The maximum ratings, which shall not be exceeded at any time during use or storage, applicable to the connectors specified herein, are as scheduled in Table 1(b).

1.4 PARAMETER DERATING INFORMATION (FIGURE 1)

The derating information applicable to the connectors specified herein is shown in Figure 1.

1.5 PHYSICAL DIMENSIONS

The physical dimensions of the connectors specified herein are shown in Figures 2(a) and 2(b).

1.6 STANDARD TEST CONNECTOR INTERFACE

Whenever gauges are required for mating with the connectors under test, their physical dimensions shall be in accordance with those specified in Figure 3.

TABLE 1(a) - TYPE VARIANTS

VARIANT	DESCRIPTION
01	Straight Jack, Solder Type, for Semi-Rigid Cable Ø2.20mm (0.085")
02	Straight Jack, Solder Type, for Semi-Rigid Cable Ø3.58mm (0.141")
03	Straight Plug with Cable Clamp, Solder Type, for Semi-Rigid Cable Ø6.35mm (0.250")
04	Straight Plug with Cable Clamp, Solder Type, for Semi-Rigid Cable Microporous Ø6.35mm (0.250")
05	Straight Jack, Crimp-Type, Square Flange
06	Straight Jack, Crimp-Type
07	Straight Jack, Crimp-Type, for Cable Ø 5mm/50Ω, Single Braid
08	Straight Jack, Crimp-Type, for Cable Ø 5mm/50Ω, Double Braid
09	Straight Jack, Solder Type, Back Mounting, 2-Hole, Flange-Mounted, for Semi-Rigid Cable Ø2.20mm (0.085")
10	Straight Jack, Solder Type, Back Mounting, 2-Hole, Flange-Mounted, for Semi-Rigid Cable Ø3.58mm (0.141")
11	Straight Jack, Crimp-Type, Square Flange
12	Straight Jack, Crimp-Type, Square Flange (50 CIS)
13	Straight Jack, Crimp- or Solder-Type, Square Flange
14	Straight Jack, Crimp- or Solder-Type, Square Flange, Double Braid Cable
15	Square Flange Receptacle, Front Mounting (Note 3)
16	2-Hole Flange Receptacle for Micro-Strip, Front Mounting
17	2-Hole Flange Receptacle, Front Mounting (Note 3)
18	2-Hole Flange Receptacle for Micro-Strip, Front Mounting (Note 3)
19	Square Flange Receptacle for Micro-Strip, Front Mounting, Off-Set Tab
20	2-Hole Flange Receptacle for Strip Line, Front Mounting
21	Square Flange Receptacle for Strip Line, Front Mounting
22	Square Flange Receptacle for Micro-Strip, Front Mounting (Note 3)
23	Bulkhead Receptacle
24	Bulkhead Receptacle with Sealing Gasket
25	Hermetic Bulkhead Receptacle
26	Hermetic Receptacle, Solder Type
27	Elbow Receptacle, Square Flange
28	Elbow Receptacle, Square Flange
29	Square Flange Receptacle (Note 3)
30	2-Hole Flange Receptacle (Note 3)
31	Square Flange Receptacle (Note 3)
32	2-Hole Flange Receptacle (Note 3)
33	Not to be used
34	Flange Receptacle, Triplate Launcher
35	Not to be used
36	Square Flange Receptacle
37	Flange Receptacle, Triplate Launcher
38	Flange Receptacle, Triplate Launcher
39	Square Flange Receptacle
40	Square Flange Receptacle, Low RF Leakage (Note 3)
41	Square Flange Receptacle, Low RF Leakage
42	Square Flange Receptacle, Low RF Leakage
43	Square Flange Receptacle, Low RF Leakage
44	Bulkhead Receptacle
45	Square Flange Receptacle for Micro-Strip

NOTES: See Page 7.

TABLE 1(a) - TYPE VARIANTS (CONT'D)

VARIANT	DESCRIPTION
46	2-Hole Flange Receptacle for Strip Line
47	2-Hole Flange Receptacle for Strip Line (Non-Captivated Centre Contact)
48	Square Flange Male Receptacle for Micro-Strip (Non-Captivated Centre Contact)
49	2-Hole Flange Receptacle
50	Square Flange Receptacle
51	Square Flange Receptacle
52	Not to be used
53	Straight Jack, Solder Type, for SHF 5 Cable
54	2-Hole Flange Receptacle, Low RF Leakage (Note 3)
55	Elbow Receptacle, Round Flange, Triplate Launcher
56	Square Flange Receptacle, Low RF Leakage
57	Round Flange Receptacle, Triplate Launcher
58	Square Flange Receptacle, Low RF Leakage
59	2-Hole Flange Male Receptacle with EMI Gasket and Glass Seal ϕ Contact 0.46
60	Bulkhead Receptacle with Glass Seal ϕ Contact 0.30 (Note 3)
61	Bulkhead Receptacle with Glass Seal ϕ Contact 0.46 (Note 3)
62	Hermetic Bulkhead Receptacle*
63	Hermetic Bulkhead Receptacle
64	Hermetic Bulkhead Receptacle
65	2-Hole Flange Male Receptacle with EMI Gasket and Glass Seal ϕ Contact 0.30
66	Bulkhead Jack, Solder Type, for SHF 3 Cable
67	Bulkhead Jack, Solder Type, for SHF 8 Cable
68	Straight Jack, Solder Type, Back Mounting, Flange-Mounted, for Semi-Rigid Cable ϕ 2.20mm (0.085")
69	Straight Jack, Solder Type, Back Mounting, Flange-Mounted, For Semi-Rigid Cable ϕ 3.58mm (0.141")
70	Straight Jack, Crimp-Type, (50 CIS)
71	Elbow Receptacle, Square Flange (Solid Contact), (Note 3)
72	Square Flange Receptacle, Tab Contact, Low RF Leakage
73	Square Flange Receptacle, Front Mounting, Maximum Operating Temperature = +165°C (Note 3)
74	2-Hole Flange Receptacle, Front Mounting, Maximum Operating Temperature = +165°C (Note 3)
75	2-Hole Flange Receptacle for Micro-Strip, Front Mounting, Maximum Operating Temperature = +165°C (Note 3)
76	Square Flange Receptacle for Micro-Strip, Front Mounting, Maximum Operating Temperature = +165°C (Note 3)
77	Square Flange Receptacle, Maximum Operating Temperature = +165°C (Note 3)
78	2-Hole Flange Receptacle, Maximum Operating Temperature = +165°C (Note 3)
79	Square Flange Receptacle, Maximum Operating Temperature = +165°C (Note 3)
80	2-Hole Flange Receptacle, Maximum Operating Temperature = +165°C (Note 3)
81	Square Flange Receptacle, Low RF Leakage, Maximum Operating Temperature = +165°C (Note 3)
82	2-Hole Flange Receptacle, Low RF Leakage, Maximum Operating Temperature = +165°C (Note 3)
83	Bulkhead Receptacle with Glass Seal ϕ Contact 0.30, Maximum Operating Temperature = +165°C (Note 3)
84	Bulkhead Receptacle with Glass Seal ϕ Contact 0.46, Maximum Operating Temperature = +165°C (Note 3)
85	Elbow Receptacle, Square Flange (Solid Contact), Maximum Operating Temperature = +165°C (Note 3)

NOTES

1. The Variants are described in Figure 2(b).
2. For finishes, see Para. 4.4.
3. Variants 73 through 85 inclusive are High Temperature Capability versions of Variants 15, 17, 18, 22, 29, 30, 31, 32, 40, 54, 60, 61 and 71 respectively.



TABLE 1(b) - MAXIMUM RATINGS

No.	CHARACTERISTICS	SYMBOL	MAXIMUM RATINGS	UNIT	REMARKS
1	Peak Power at +25°C	P _{max}	20	kW	1.0μs
2	Power	P	2.0	kW	See Figures 1(a) and 1(b)
3	Nominal Impedance	Z	50	Ω	-
4	Frequency Range	f	See Figure 2(b)	GHz	-
5	Operating Voltage	V _{op}	335	V _{rms}	
6	Operating Temperature Range	T _{op}	See Figure 2(b)	°C	-
7	Storage Temperature Range	T _{stg}	As per Operating Temperature Range	°C	-



FIGURE 1 - PARAMETER DERATING INFORMATION

FIGURE 1(a) - POWER VERSUS TEMPERATURE

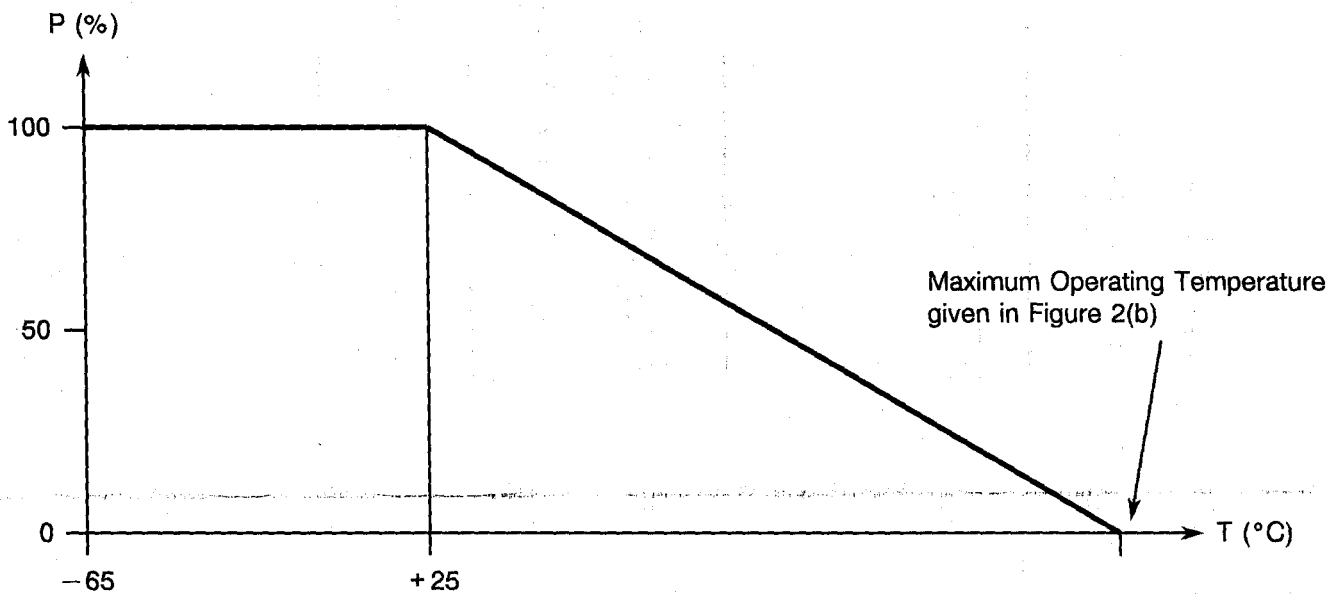
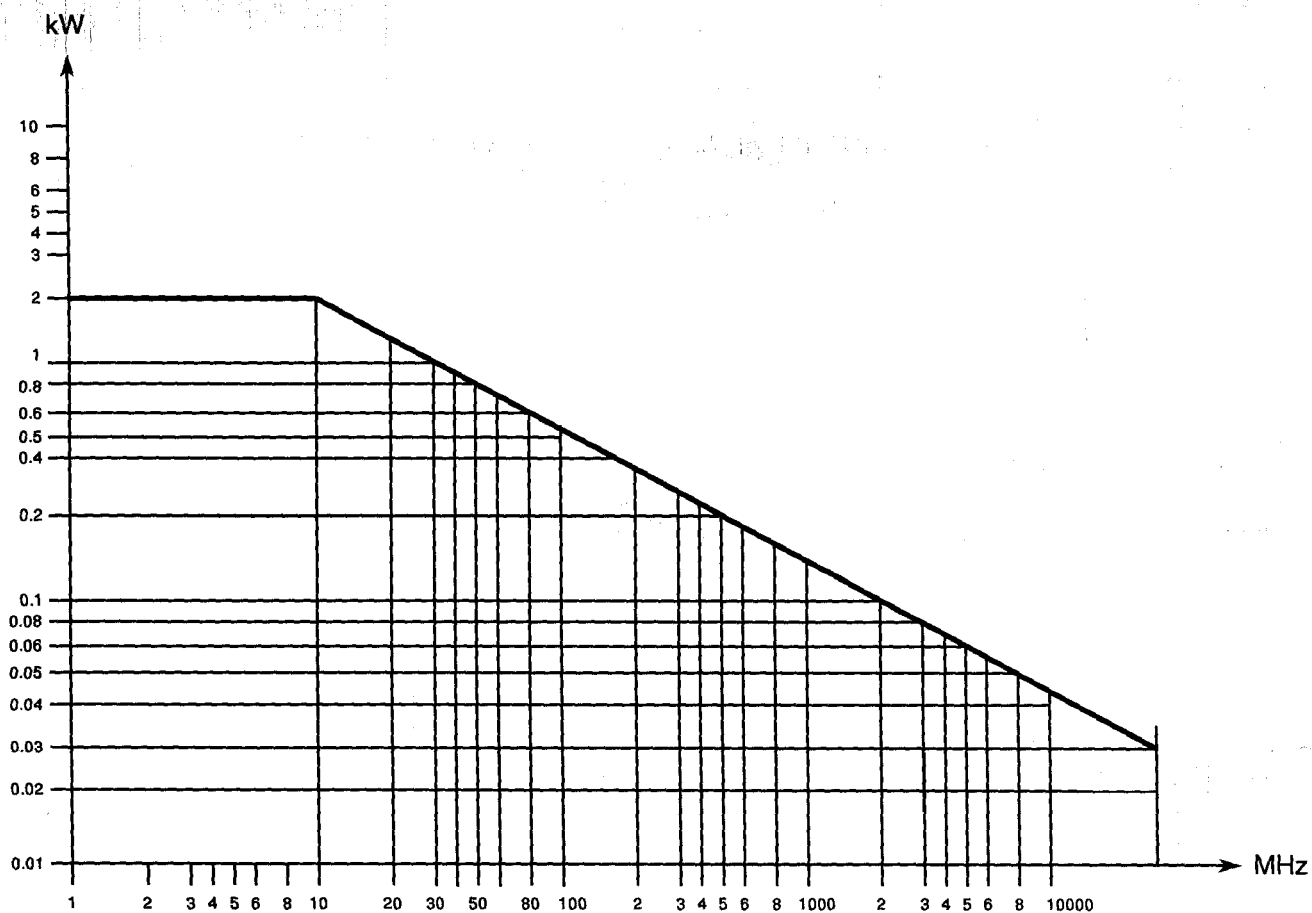

FIGURE 1(b) - POWER VERSUS FREQUENCY



POWER (VSWR in line 1) at $T_{amb} = +40^{\circ}C$.

FIGURE 2 - PHYSICAL DIMENSIONS

FIGURE 2(a) - CONNECTOR INTERFACE - FEMALE CONTACT

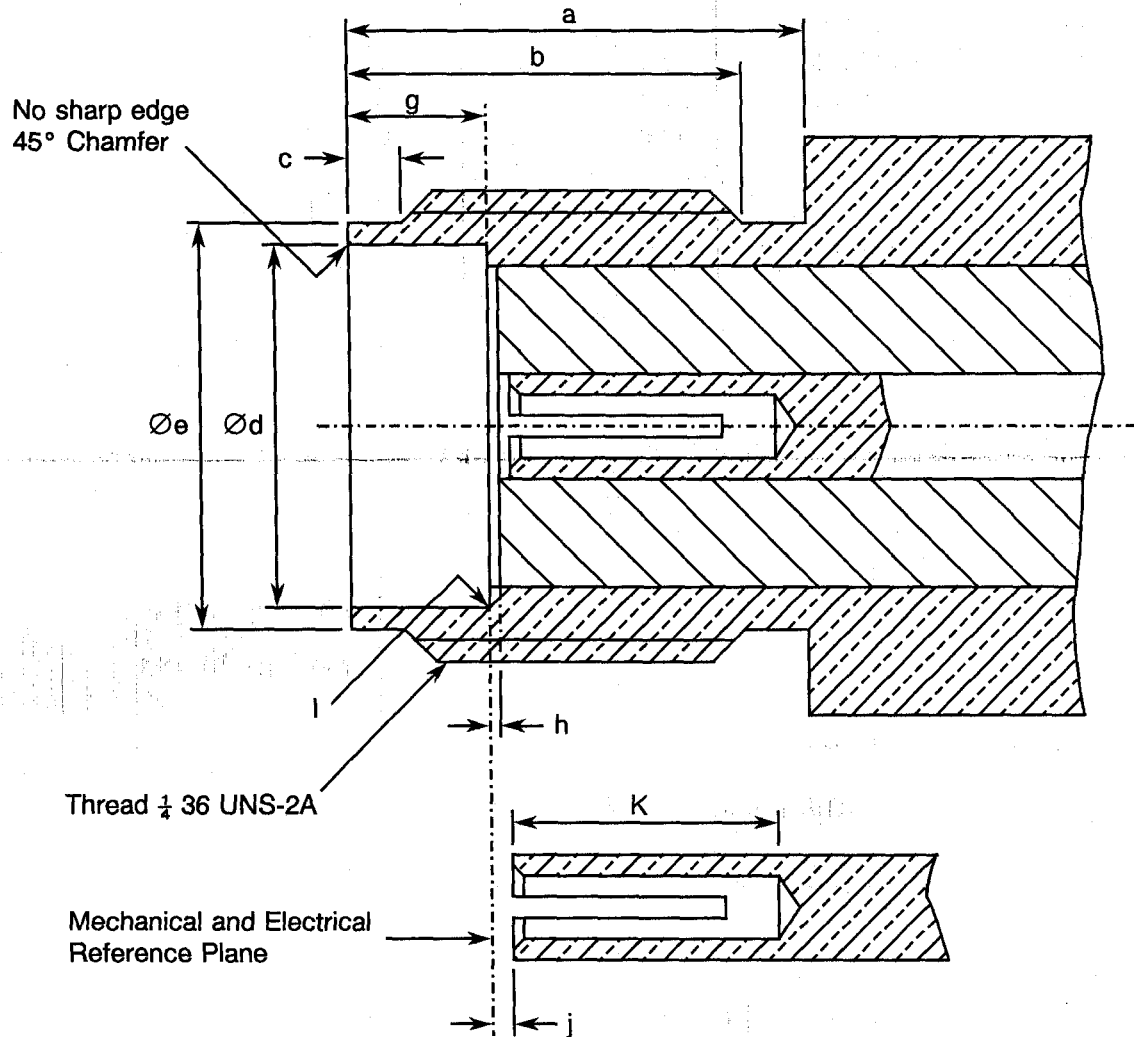

SYMBOL	MILLIMETRES		NOTES
	MIN.	MAX.	
a	5.54	-	
b	4.32	-	
c	0.38	1.14	
Ød	4.597	4.67	
Øe	5.28	5.49	
g	1.88	1.98	
h	0.00	0.20	
j	0.00	0.25	
K	2.92	-	
l	-	0.04	Radius

FIGURE 3 - STANDARD TEST CONNECTOR INTERFACE - MALE CONTACT

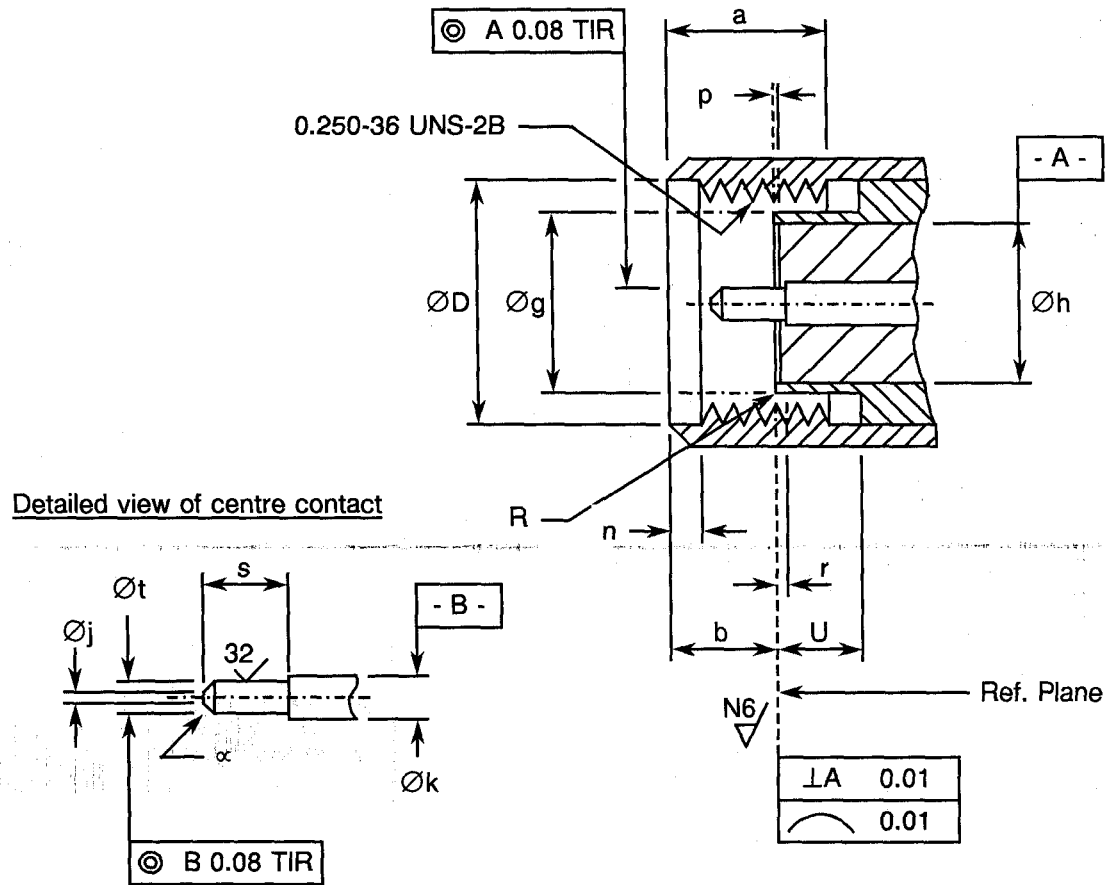

SYMBOL	MILLIMETRES		NOTES	
	MIN.	MAX.		
a	3.71	4.32	Flat	
b	2.59	3.35		
ØD	6.48	6.73		
Øg	4.34	4.59		
Øh	4.10	4.13		
Øj	-	0.38		
Øk	1.27	1.29		
n	0.64	1.14		
p	0.00	0.05		Insert recess
r	0.00	0.08		Contact recessed
R	-	0.08		Radius
s	2.03	2.29		
Øt	0.90	0.93		
U	2.03	-		
α	-	-	45 ± 3° Chamfer	

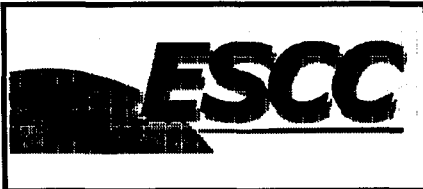

2. APPLICABLE DOCUMENTS

The following documents form part of this specification and shall be read in conjunction with it:-

- (a) ESCC Generic Specification No. 3402 for RF Coaxial Connectors.
- (b) MIL-G-45204, Gold Plating, Electrodeposited.

3. TERMS, DEFINITIONS, ABBREVIATIONS, SYMBOLS AND UNITS

For the purpose of this specification, the terms, definitions, abbreviations, symbols and units specified in ESCC Basic Specification No. 21300 shall apply.

4. REQUIREMENTS

4.1 GENERAL

The complete requirements for procurement of the connectors specified herein are stated in this specification and ESCC Generic Specification No. 3402. Deviations from the Generic Specification applicable to this specification only, are listed in Para. 4.2.

Deviations from the applicable Generic Specification and this Detail Specification, formally agreed with specific Manufacturers on the basis that the alternative requirements are equivalent to the ESCC requirements and do not affect the components' reliability, are listed in the appendices attached to this specification.

4.2 DEVIATIONS FROM GENERIC SPECIFICATION

4.2.1 Deviations from Special In-process Controls

None.

4.2.2 Deviations from Final Production Tests (Chart II)

For Variants 01, 02, 03, 04, 09, 10, 20, 46, 47, 48, 53, 55, 57, 66 and 67, the tests: Change of Temperature (Para. 9.26), Insulation Resistance (Para. 9.1) and Voltage Proof (Para. 9.2) are not applicable (Variants delivered with unmounted contact and insulator).

4.2.3 Deviations from Burn-in Tests (Chart III)

Not applicable.

4.2.4 Deviations from Qualification Tests (Chart IV)

None.

4.2.5 Deviations from Lot Acceptance Tests (Chart V)

None.



4.3 MECHANICAL REQUIREMENTS

4.3.1 Dimension Check

The dimensions of the connectors specified herein shall be verified in accordance with the requirements set out in Para. 9.25 of ESCC Generic Specification No. 3402 and shall conform to those shown in Figures 2(a) and 2(b) of this specification.

4.3.2 Weight

The maximum weight of the connectors specified herein shall be as specified in Figure 2(b).

4.3.3 Coupling Proof Torque

The requirements for testing of the coupling proof torque are specified in Section 9 of ESCC Generic Specification No. 3402. The applied torque shall be 170N.cm.

4.3.4 Cable Retention Force

The requirements for testing of the cable retention force are specified in Section 9 of ESCC Generic Specification No. 3402. Figure 2(b) specifies the values for axial loads. Torque shall be applied as follows:-

4.3.4.1 Flexible Cables

Flexible cables shall be rotated 180° in both directions.

Rotational movement shall be applied at 15cm from the connector.

4.3.4.2 Semi-rigid Cables

The torque value shall be as follows:-

RG 405/U : 11.28N.cm.

RG 402/U : 38.85N.cm.

RG 401/U : 38.85N.cm.

4.3.5 Mating and Unmating Forces

The applicable measurement requirements are specified in Section 9 of ESCC Generic Specification No. 3402. The maximum torque during mating and unmating shall not exceed 24N.cm.

Whenever a test is performed on mated pairs of connectors, the pairs shall be torqued at 80-120N.cm.

4.3.6 Endurance

The applicable test requirements are specified in Section 9 of ESCC Generic Specification No. 3402. The test conditions shall be as follows:-

(a) Number of cycles : 500 for qualification; 100 for lot acceptance.

(b) Rate : 12 cycles maximum/minute.

4.3.7 Residual Magnetism

The applicable measurement requirements are specified in Section 9 of ESCC Generic Specification No. 3402.

4.3.7.1 Beryllium copper, copper underplate, gold-plated connectors. The maximum allowable value shall not exceed 20 gammas.

4.3.7.2 Beryllium copper, nickel underplate, gold-plated connectors. There are no requirements in respect of residual magnetism. This version is made such that the residual magnetism does not exceed 2000 gammas.

4.3.7.3 Residual magnetism is not applicable to stainless steel versions.

4.3.8 Contact Engagement and Separation Forces

The requirements for these measurements are specified in Section 9 of ESCC Generic Specification No. 3402 and apply to female contacts only.

(a) Oversize Pin

Steel test pin diameter : 0.9525/0.955 mm.
Insertion depth : 0.76/1.14 mm.
Number of insertions : 3.

(b) Engagement Force Test (Maximum Diameter Test Pin)

Steel test pin diameter : 0.940/0.942 mm.
Engagement depth : 1.27/1.91 mm.
Engagement force : 1360g max.

(c) Separation Force Test (Minimum Diameter Test Pin)

Steel test pin diameter : 0.902/0.904 mm.
Separation depth : 1.27/1.91 mm.
Separation force : 28.4g min.

FIGURE 4 - TEST PIN CONFIGURATION

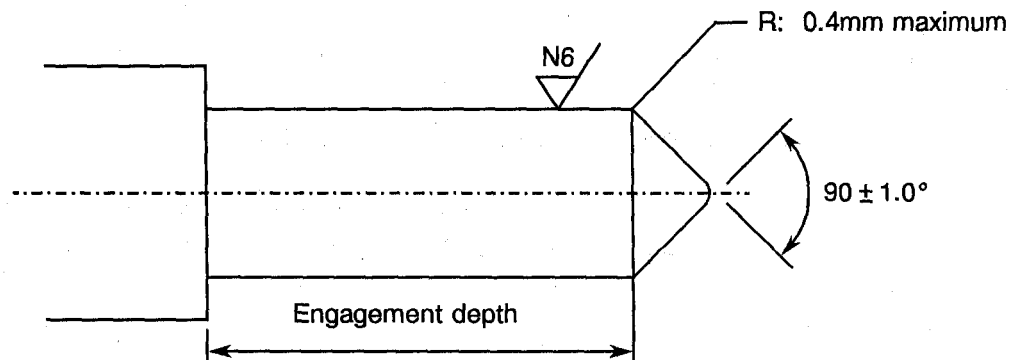

4.3.9 Contact Retention

The requirements for this test are specified in Section 9 of ESCC Generic Specification No. 3402. The test conditions are given in Figure 2(b). After testing, the connector interface dimensions shall be within the limits of Figure 2(a).

4.4 MATERIALS AND FINISHES

The materials and finishes shall be as specified herein. Where a definite material is not specified, a material which will enable the connectors specified herein to meet the performance requirements of this specification shall be used. Acceptance or approval of any constituent material does not guarantee acceptance of the finished product.



4.4.1 Beryllium Copper Version Gold Plated

(a) Shell, Coupling Nut, Centre Contact

Material : Beryllium copper (or brass for male contact only).

(i) Plating for standard version

Underplate : Nickel, 2.0 μ m minimum.

Plating : Gold, 1.27 μ m minimum, Type 2 Grade C of MIL-G-45204.

(ii) Plating for amagnetic version

Underplate : Copper, 2.5 μ m minimum.

Plating : Gold, 2.5 μ m minimum, Type 2 Grade C of MIL-G-45204.

(b) Inserts

Material : PTFE.

(c) Gaskets

Material : Silicone rubber.

(d) Accessories (ferrule, crimping or solder sleeves and nut)

Material : Brass or copper.

(i) Plating for standard version

Underplate : Nickel, 2.0 μ m minimum.

Plating : Gold, 0.5 μ m minimum, Type 2 Grade C of MIL-G-45204.

(ii) Plating for amagnetic version

Underplate : Copper, 2.5 μ m minimum.

Plating : Gold, 2.5 μ m minimum, Type 2 Grade C of MIL-G-45204.

4.4.2 Stainless Steel Version Electro-passivated

(a) Shell, Coupling Nut

Material : Stainless steel, electro-passivated.

For solder-type connectors: Rear part of shell shall be protected with:

Underplate : Nickel, 2.0 μ m minimum.

Plating : Gold, 1.27 μ m minimum, Type 2 Grade C of MIL-G-45204.

(b) Centre Contact

Material : Beryllium copper (or brass for male contact only).

Underplate : Nickel, 2.0 μ m minimum.

Plating : Gold, 1.27 μ m minimum, Type 2 Grade C of MIL-G-45204.

(c) Inserts

Material : PTFE.

(d) Gaskets

Material : Silicone.



(e) Accessories

- Crimping sleeve
 - Material : Brass or copper.
 - Plating : Nickel, 2.0µm minimum.
- Solder sleeve
 - Material : Brass or copper.
 - Underplate : Nickel, 2.0µm minimum.
 - Plating : Gold, 0.5µm minimum, Type 2 Grade C of MIL-G-45204.
- Nut
 - Material : Stainless steel, electro-passivated.
- Washers
 - Material : Beryllium copper.
 - Plating : Nickel, 2.0µm minimum.

4.4.3 Stainless Steel Version Gold Plated

(a) Shell, Coupling Nut

- Material : Stainless steel.
- Underplate : Nickel, 2.0µm minimum.
- Plating : Gold, 1.27µm minimum, Type 2 Grade C of MIL-G-45204.

(b) Centre Contact

- Material : Beryllium copper (or brass for male contact only).
- Underplate : Nickel, 2.0µm minimum.
- Plating : Gold, 1.27µm minimum, Type 2 Grade C of MIL-G-45204.

(c) Inserts

- Material : PTFE.

(d) Gaskets

- Material : Silicone.

(e) Accessories

- Crimping or solder sleeve
 - Material : Brass or copper.
 - Underplate : Nickel, 2.0µm minimum.
 - Plating : Gold, 0.5µm minimum, Type 2 Grade C of MIL-G-45204.
- Nut
 - Material : Stainless steel, electro-passivated.
 - Underplate : Nickel, 2.0µm minimum.
 - Plating : Gold, 0.5µm minimum, Type 2 Grade C of MIL-G-45204.
- Washers
 - Material : Beryllium copper.
 - Underplate : Nickel, 2.0µm minimum.
 - Plating : Gold, 0.5µm minimum, Type 2 Grade C of MIL-G-45204.

4.4.4 Iron Nickel Gold Plated Hermetic Type

(a) **Shell**

Material : Iron.
 Underplate : Nickel, 2.0µm minimum.
 Plating : Gold, 1.27µm minimum, Type 2 Grade C of MIL-G-45204.

(b) **Centre Contact**

Material : Steel.
 Underplate : Nickel, 2.0µm minimum.
 Plating : Gold, 1.27µm minimum, Type 2 Grade C of MIL-G-45204.

(c) **Inserts**

Material : Glass.

4.5 MARKING

4.5.1 General

The marking of all components delivered to this specification shall be in accordance with the requirements of ESCC Basic Specification No. 21700 and the following paragraphs. Each component shall be marked in respect of:-

- (a) The ESCC Component Number.
- (b) Characteristics.
- (c) Traceability Information.

4.5.2 The ESCC Component Number

Each component shall bear the ESCC Component Number which shall be constituted and marked as follows:-

340200215B

Detail Specification Number _____

Type Variant (see Table 1(a)) _____

Testing Level (B or C, as applicable) _____

4.5.3 Characteristics

Characteristics cover the type of plating/material and 2 different dimensional aspects:

- (a) Variants of fixed configuration.
- (b) Variants where the rear end (length of contact A and length of insert B) may vary within a range limited by a specified maximum value.

4.5.3.1 Variants of Fixed Configuration

Each component shall be marked in respect of:-

- (a) Type of plating/material.
- (b) Number.

The information shall be constituted and marked as follows:

201

Type of plating/material (see Para. 4.5.3.3) _____

Number (shall always be 01) _____

4.5.3.2 Variants where Dimensions A and B of Figure 2(b) are Indicated by a Maximum Only

Each component shall be marked in respect of:-

- (a) Type of plating/material.
- (b) Length and tolerance of centre contact (dimension A) (see Note 4).
- (c) Length and tolerance of insert (dimension B) (see Note 4).

The information shall be constituted and marked as follows:

Type of plating/material (see Para. 4.5.3.3) _____ 213D00W02D50C
 Contact length A: 13mm (see Para. 4.5.3.4) _____
 Tolerance on A: $\pm 0.05\text{mm}$ (see Para. 4.5.3.5) _____
 Insert length B: 2.5mm (see Para. 4.5.3.4) _____
 Tolerance on B: $\pm 0.25\text{mm}$ (see Para. 4.5.3.5) _____

NOTES

1. Dimension A shall always be greater than B. Both values shall always be positive.
2. When dimension B (insert) is flush with the flange ($B = 0$), the insert length shall be marked 00D00 with the appropriate tolerance.
3. When applicable, Figure 2(b) makes reference to Para. 4.5.3.
4. The length values of the centre contact and insert shall be marked only on the primary package.

4.5.3.3 Type of Plating/Material

The type of plating/material shall be identified by means of the following code:-

CODE	TYPE OF PLATING/MATERIAL	PARA.
1	Beryllium copper gold plated, copper underplate (amagnetic version)	4.4.1
2	Beryllium copper gold plated, nickel underplate (standard version)	4.4.1
3	Stainless steel electro-passivated	4.4.2
4	Stainless steel gold plated	4.4.3

For hermetic types (see Para. 4.4.4), only plating code 2 is available.

4.5.3.4 Length Values

Length values shall be expressed by means of the following codes. The unit quantity for marking shall be millimetres.

LENGTH VALUE	CODE
XX.XX	XXDXX

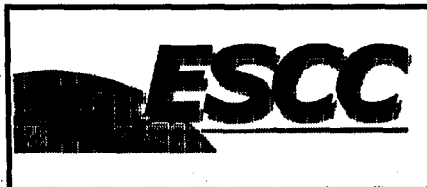

4.5.3.5 Tolerance

The tolerances on length values shall be indicated by the letter codes specified hereafter:-

TOLERANCE (mm)	CODE LETTER
± 0.05	W
± 0.10	B
± 0.25	C

4.5.4 Traceability Information

Each component shall be marked in respect of traceability information in accordance with the requirements of ESCC Basic Specification No. 21700.

4.5.5 Marking of Small Components

When it is considered that the component is too small to accommodate the marking as specified above, as much as space permits shall be marked. The order of precedence shall be as specified in Para. 4.5.1. The marking information in full shall accompany each component in its primary package.

4.6 ELECTRICAL MEASUREMENTS

4.6.1 Electrical Measurements at Room Temperature

The parameters to be measured in respect of electrical characteristics are scheduled in Table 2. Unless otherwise specified, the measurements shall be performed at $T_{amb} = +22 \pm 3$ °C.

4.6.2 Electrical Measurements at High and Low Temperatures (Table 3)

Not applicable.

4.6.3 Circuits for Electrical Measurements

Not applicable.

4.7 BURN-IN TESTS (TABLES 4 AND 5)

Not applicable.



TABLE 2 - ELECTRICAL MEASUREMENTS AT ROOM TEMPERATURE

No.	CHARACTERISTICS	SYMBOL	SPEC. AND/OR TEST METHOD	TEST CONDITIONS	LIMITS		UNIT
					MIN	MAX	
1	Insulation Resistance	R _i	ESCC 3402, Para. 9.1	500 Vdc	5000	-	MΩ
2	Voltage Proof Leakage Current	I _L	ESCC 3402, Para. 9.2	See Figure 2(b)	-	2.0	mA

TABLES 3, 4 AND 5

Not applicable.

4.8 ENVIRONMENTAL AND ENDURANCE TESTS (CHARTS IV AND V OF ESCC GENERIC SPECIFICATION No. 3402)

4.8.1 Measurements and Inspections on Completion of Environmental Tests

The parameters to be measured on completion of environmental tests are scheduled in Table 6 of this specification. Unless otherwise stated, the measurements shall be performed at T_{amb} = +22 ± 3 °C.

4.8.2 Measurements and Inspections at Intermediate Points during Endurance Tests

Not applicable.

4.8.3 Measurements and Inspections on Completion of Endurance Tests

The parameters to be measured on completion of endurance tests are scheduled in Table 6 of this specification. Unless otherwise stated, the measurements shall be performed at T_{amb} = +22 ± 3 °C.

4.8.4 Conditions for Operating Life Tests (Part of Endurance Testing)

Not applicable.

4.8.5 Electrical Circuits for Operating Life Tests

Not applicable.

4.8.6 Conditions for High Temperature Storage Test (Part of Endurance Testing)

The requirements for the high temperature storage test are specified in Section 9 of ESCC Generic Specification No. 3402. The conditions for high temperature storage shall be the maximum operating temperature as specified in Figure 2(b).

TABLE 6 - MEASUREMENTS AND INSPECTIONS ON COMPLETION OF ENVIRONMENTAL AND ENDURANCE TESTS

NO.	ESCC GENERIC SPEC. NO. 3402		MEASUREMENTS AND INSPECTIONS		SYMBOL	LIMITS		UNIT
	ENVIRONMENTAL AND ENDURANCE TESTS (1)	TEST METHOD AND CONDITIONS	IDENTIFICATION	CONDITIONS		MIN.	MAX.	
01	Coupling Proof Torque	Para. 9.4	Final Measurements Interface Dimensions Visual Examination	- Para. 9.4 of ESCC 3402	- -	Figure 2(a)		- -
02	Mating and Unmating Forces	Para. 9.5	During Test Torque	Para. 4.3.5 of this spec.	-	-	24	N.cm
03	Seal Test	Para. 9.7	Hermeticity Leakage	If applicable As applicable	- -	-	1.10 ⁻⁸ No Bubbles	cm ³ /s -
04	External Visual Inspection	Para. 9.8	External Visual Inspection	Para. 9.8 of ESCC 3402	-	-	-	-
05	Contact Resistance	Para. 9.9 6V 10mA	During Test Contact Resistance	Centre Contact Shell Hermetic Centre Contact	- - -	-	3.0 2.0 10	mΩ mΩ mΩ
06	Vibration	Para. 9.10 Full Engagement	During Test Electrical Measurements Final Measurements Visual Examination Contact Resistance	Last cycle in each direction No open or short circuits No evidence of damage Centre Contact (6V 10mA)	- - - -	-	- - 3.0	- - mΩ
07	Shock or Bump	Para. 9.11 Full Engagement	Final Measurements Visual Examination Contact Resistance	No evidence of damage Centre Contact (6V 10mA)	- -	-	3.0	mΩ
08	Rapid Change of Temperature	Para. 9.12	Final Measurements Contact Resistance Voltage Proof Leakage Current Visual Examination	After a recovery period of 24 ± 2 hrs Centre Contact (6V 10mA) Table 2 Item 2	- - I _L -	-	3.0 Table 2 Item 2	mΩ -
09	Climatic Sequence	Para. 9.13	During Test Voltage Proof Final Measurements External Visual Inspection Insulation Resistance Voltage Proof Leakage Current	At Low Air Pressure 0.1X value of Figure 2(b) After final Damp Heat cycle (within 1 to 24 hrs recovery) Para. 9.8 of ESCC 3402 Table 2 Item 1 Table 2 Item 2	VP - Ri I _L	No flashover or breakdown	- - Table 2 Item 2	- - MΩ
10	Cable Retention Force	Para. 9.14 and Para. 4.3.4 of this spec.	During Test Continuity	-	-	-	-	-
11	Cabling and Crimping Capability	Para. 9.15	Visual Examination Dimensions Insulation Resistance Voltage Proof Leakage Current	Para. 9.15 of ESCC 3402 Para. 9.15 of ESCC 3402 Table 2 Item 1 Table 2 Item 2	- - Ri I _L	Fig. 2(a) & 2(b)	Table 2 Item 2	- - MΩ

NOTES

1. The tests in this Table refer to either Chart IV or V and shall be used as applicable.



TABLE 6 - MEASUREMENTS AND INSPECTIONS ON COMPLETION OF ENVIRONMENTAL AND ENDURANCE TESTS (CONT'D)

NO.	ESCC GENERIC SPEC. NO. 3402		MEASUREMENTS AND INSPECTIONS		SYMBOL	LIMITS		UNIT
	ENVIRONMENTAL AND ENDURANCE TESTS (1)	TEST METHOD AND CONDITIONS	IDENTIFICATION	CONDITIONS		MIN.	MAX.	
12	VSWR or Reflection Coefficient	Para. 9.16	VSWR	Para. 9.16 of ESCC 3402	-	Figure 2(b)		-
13	Corona Level	Para. 9.17	Corona	Para. 9.17 of ESCC 3402	-	Figure 2(b)		-
14	Endurance	Para. 9.18 and Para. 4.3.6 of this spec.	Final Measurements Mating/Unmating Forces Contact Resistance Visual Examination	Para. 4.3.5 of this spec. Centre Contact (6V 10mA) Shell (6V 10mA) Hermetic Centre Contact (6V 10mA) Para. 9.18 of ESCC 3402	- - - -	- - - -	24 4.0 3.0 12	N.cm mΩ mΩ mΩ
15	RF Insertion Loss	Para. 9.19	Insertion Loss	Para. 9.19 of ESCC 3402	-	Figure 2(b)		-
16	Corrosion	Para. 9.20	Visual Examination	Para. 9.20 of ESCC 3402 No exposure of base metal	-	-	-	-
17	Residual Magnetism	Para. 9.21	Magnetism	-	-	Para. 4.3.7		-
18	Soldering Proof	Para. 9.22	Final Measurements Interface Dimensions Mating/Unmating Forces Insulation Resistance Voltage Proof Leakage Current Contact Resistance External Visual Inspection	Para. 4.3.5 of this spec. Table 2 Item 1 Table 2 Item 2 Centre Contact (6V 10mA) Shell (6V 10mA) Hermetic Centre Contact (6V 10mA) Para. 9.8 of ESCC 3402	- Ri IL - - -	- 5000 Table 2 Item 2 - - -	Figure 2(b) 24 - 3.0 2.0 10	- N.cm MΩ - mΩ mΩ mΩ
19	RF Leakage	Para. 9.23	Leakage	-	-	Figure 2(b)		-
20	High Temperature Storage	Para. 9.24 and Para. 4.8.6 of this spec.	Final Measurements Mating/Unmating Forces Insulation Resistance Voltage Proof Leakage Current Contact Retention Visual Examination Contact Resistance External Visual Inspection	Para. 4.3.5 of this spec. Table 2 Item 1 Table 2 Item 2 Para. 4.3.9 of this spec. Centre Contact (6V 10mA) Shell (6V 10mA) Hermetic Centre Contact (6V 10mA) Para. 9.8 of ESCC 3402	- Ri IL - - -	- 5000 Table 2 Item 2 - - -	24 - - 8.0 7.5 15	N.cm MΩ - mΩ mΩ mΩ
21	Permanence of Marking	Para. 9.27	Marking Permanence	Para. 9.27 of ESCC 3402	-	-	-	-
22	Plating Thickness (Hermetic Types Only)	Para. 9.29	Plating Thickness	Para. 5.3.4 of ESCC 3402	-	-	-	-

NOTES

1. The tests in this table refer to either Chart IV or V and shall be used as applicable.

FIGURE 2(b) - VARIANTS

VARIANT 01 - STRAIGHT JACK, SOLDER TYPE, FOR SEMI-RIGID CABLE Ø2.20mm (0.085")

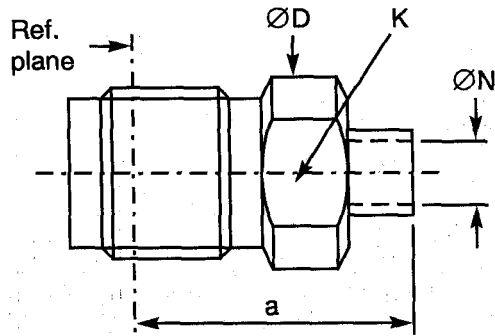

SYMBOL	MILLIMETRES		NOTES
	MIN.	MAX.	
a	10.50	11.00	
ØD	6.60	6.80	
K	-	6.00	2 flats
ØN	2.25	2.35	

ELECTRICAL CHARACTERISTICS	VALUES	UNITS
Frequency range	0 to 18	GHz
Maximum voltage standing wave ratio (VSWR)	$1.10 + 0.01 f$ (GHz)	
Maximum reflection coefficient	$0.047 + 0.004 f$ (GHz)	
Maximum insertion loss	$0.02 \sqrt{f}$ (GHz)	dB
RF leakage	$- [100 - f]$ (GHz)	dB
Voltage proof	750	Vrms
Corona level	190	Vrms

MECHANICAL CHARACTERISTICS	VALUES	UNITS
Mini centre contact retention force (axial)	Not applicable	N
Mini centre contact retention torque	Not applicable	N.cm
Mini cable retention force	200	N
Mini cable retention torque value	11.5	N.cm
Maximum weight	1.5	g

OTHER CHARACTERISTICS	VALUES	UNITS
Rapid change of temperature - peak value	+200	°C
Operating temperature range	-65 to +165	°C
Maxi leakage (panel sealed connectors)	Not applicable	
Maxi leakage (hermetic sealed connector)	Not applicable	
Solderability	Applicable	
Soldering proof	Not applicable	
Cables used	KS 1, RG 405/U, (Ø2.20mm)	

FIGURE 2(b) - VARIANTS (CONTINUED)

VARIANT 02 - STRAIGHT JACK, SOLDER TYPE, FOR SEMI-RIGID CABLE Ø3.58mm (0.141")

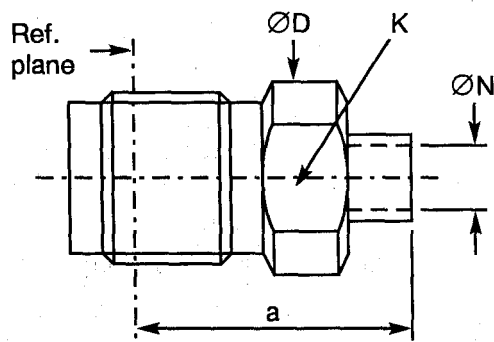

SYMBOL	MILLIMETRES		NOTES
	MIN.	MAX.	
a	10.60	11.00	2 flats
ØD	6.60	6.80	
K	-	6.00	
ØN	3.65	3.75	

ELECTRICAL CHARACTERISTICS	VALUES	UNITS
Frequency range	0 to 18	GHz
Maximum voltage standing wave ratio (VSWR)	$1.05 + 0.04 f$ (GHz)	
Maximum reflection coefficient	$0.024 + 0.0018 f$ (GHz)	
Maximum insertion loss	$0.02 \sqrt{f}$ (GHz)	dB
RF leakage	$-[100 - f]$ (GHz)	dB
Voltage proof	1000	Vrms
Corona level	250	Vrms

MECHANICAL CHARACTERISTICS	VALUES	UNITS
Mini centre contact retention force (axial)	Not applicable	N
Mini centre contact retention torque	Not applicable	N.cm
Mini cable retention force	500	N
Mini cable retention torque value	39.6	N.cm
Maximum weight	1.6	g

OTHER CHARACTERISTICS	VALUES	UNITS
Rapid change of temperature - peak value	+ 200	°C
Operating temperature range	- 65 to + 165	°C
Maxi leakage (panel sealed connectors)	Not applicable	
Maxi leakage (hermetic sealed connector)	Not applicable	
Solderability	Applicable	
Soldering proof	Not applicable	
Cables used	KS 2, RG 402/U, (Ø3.58mm)	

FIGURE 2(b) - VARIANTS (CONTINUED)

VARIANT 03 - STRAIGHT PLUG WITH CABLE CLAMP, SOLDER TYPE, FOR SEMI-RIGID CABLE
Ø6.35mm (0.250")

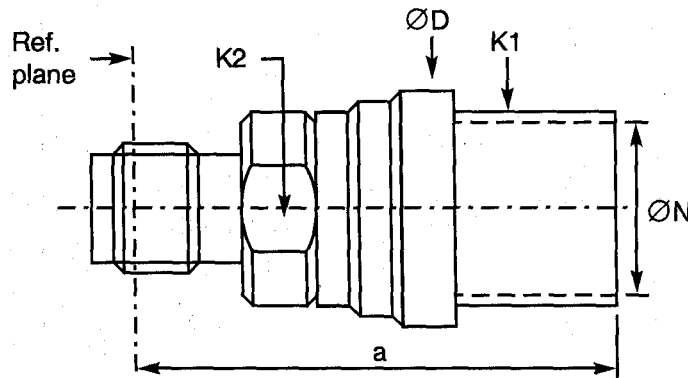

SYMBOL	MILLIMETRES		NOTES
	MIN.	MAX.	
a	21.50	22.50	
ØD	10.90	11.10	
K1	-	10.00	2 flats
K2	-	8.00	2 flats
ØN	6.45	6.70	

ELECTRICAL CHARACTERISTICS	VALUES	UNITS
Frequency range	0 to 18	GHz
Maximum voltage standing wave ratio (VSWR)	$1.05 + 0.015 f$ (GHz)	
Maximum reflection coefficient	$0.024 + 0.0063 f$ (GHz)	
Maximum insertion loss	$0.02 \sqrt{f}$ (GHz)	dB
RF leakage	$- [95 - f]$ (GHz)	dB
Voltage proof	1000	Vrms
Corona level	250	Vrms

MECHANICAL CHARACTERISTICS	VALUES	UNITS
Mini centre contact retention force (axial)	Not applicable	N
Mini centre contact retention torque	Not applicable	N.cm
Mini cable retention force	300	N
Mini cable retention torque value	39.6	N.cm
Maximum weight	7.8	g

OTHER CHARACTERISTICS	VALUES	UNITS
Rapid change of temperature - peak value	+ 200	°C
Operating temperature range	- 65 to + 165	°C
Maxi leakage (panel sealed connectors)	Not applicable	
Maxi leakage (hermetic sealed connector)	Not applicable	
Solderability	On centre contact only	
Soldering proof	Not applicable	
Cables used	KS 3, RG 401/U, (Ø6.35mm)	

FIGURE 2(b) - VARIANTS (CONTINUED)

**VARIANT 04 - STRAIGHT PLUG WITH CABLE CLAMP, SOLDER TYPE, FOR SEMI-RIGID CABLE
MICROPOROUS $\text{Ø}6.35\text{mm}$ (0.250")**

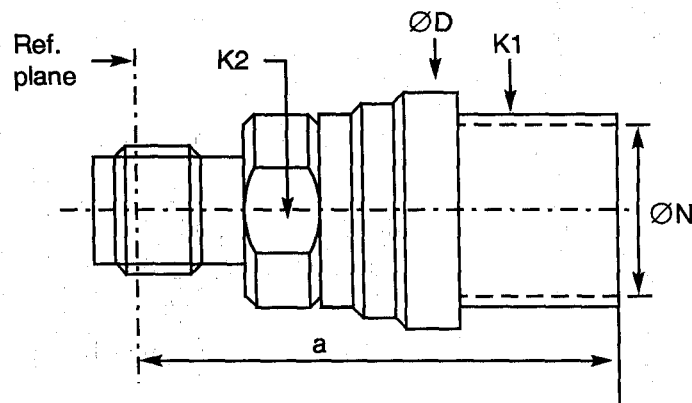

SYMBOL	MILLIMETRES		NOTES
	MIN.	MAX.	
a	21.50	22.50	
ØD	10.90	11.10	
K1	-	10.00	2 flats
K2	-	8.00	2 flats
ØN	6.45	6.70	

ELECTRICAL CHARACTERISTICS	VALUES	UNITS
Frequency range	0 to 18	GHz
Maximum voltage standing wave ratio (VSWR)	$1.05 + 0.015 f$ (GHz)	
Maximum reflection coefficient	$0.024 + 0.0063 f$ (GHz)	
Maximum insertion loss	$0.02 \sqrt{f}$ (GHz)	dB
RF leakage	$- [95 - f]$ (GHz)	dB
Voltage proof	1000	Vrms
Corona level	250	Vrms

MECHANICAL CHARACTERISTICS	VALUES	UNITS
Mini centre contact retention force (axial)	Not applicable	N
Mini centre contact retention torque	Not applicable	N.cm
Mini cable retention force	300	N
Mini cable retention torque value	39.6	N.cm
Maximum weight	7.8	g

OTHER CHARACTERISTICS	VALUES	UNITS
Rapid change of temperature - peak value	+ 200	°C
Operating temperature range	- 65 to + 165	°C
Maxi leakage (panel sealed connectors)	Not applicable	
Maxi leakage (hermetic sealed connector)	Not applicable	
Solderability	On centre contact only	
Soldering proof	Not applicable	
Cables used	Microporous $\text{Ø}6.35\text{mm}$	

FIGURE 2(b) - VARIANTS (CONTINUED)

VARIANT 05 - STRAIGHT JACK, CRIMP-TYPE, SQUARE FLANGE

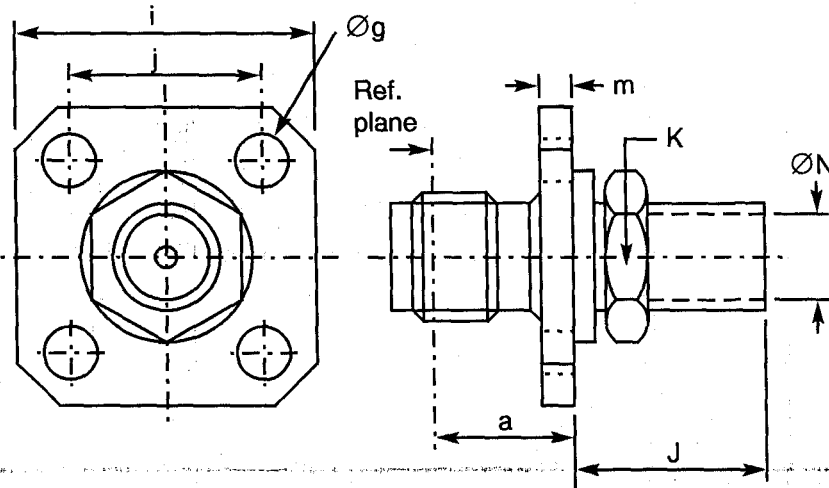

SYMBOL	MILLIMETRES		NOTES
	MIN.	MAX.	
a	7.40	7.75	2 flats
Øg	2.55	2.70	
i	12.60	12.80	
j	8.59	8.69	
J	-	17.30	
K	-	7.00	
m	1.40	1.80	
ØN	2.55	2.65	

ELECTRICAL CHARACTERISTICS	VALUES	UNITS
Frequency range	0 to 12.4	GHz
Maximum voltage standing wave ratio (VSWR)	$1.10 + 0.015 f$ (GHz)	
Maximum reflection coefficient	$0.047 + 0.0063 f$ (GHz)	
Maximum insertion loss	$0.03 \sqrt{f}$ (GHz)	dB
RF leakage	$- [95 - f$ (GHz)]	dB
Voltage proof	750	Vrms
Corona level	190	Vrms

MECHANICAL CHARACTERISTICS	VALUES	UNITS
Mini centre contact retention force (axial)	27	N
Mini centre contact retention torque	0.5	N.cm
Mini cable retention force	80	N
Mini cable retention torque value	$2 \times 180^\circ$ applic. point $50 \times \text{ØN}$	
Maximum weight	4.9	g

OTHER CHARACTERISTICS	VALUES	UNITS
Rapid change of temperature - peak value	+200 (see cables used)	°C
Operating temperature range	-65 to +165	°C
Maxi leakage (panel sealed connectors)	Not applicable	
Maxi leakage (hermetic sealed connector)	Not applicable	
Solderability	Applicable	
Soldering proof	Not applicable	
Cables used	KX 21 A, RG 178/U	

FIGURE 2(b) - VARIANTS (CONTINUED)

VARIANT 06 - STRAIGHT JACK, CRIMP-TYPE

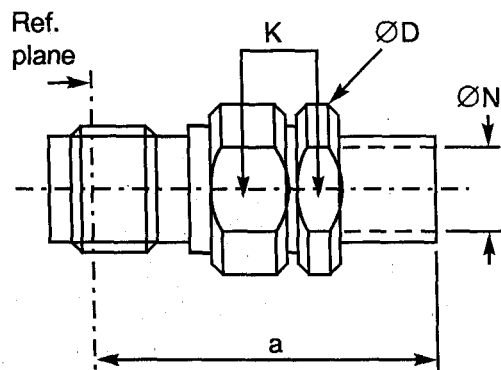

SYMBOL	MILLIMETRES		NOTES
	MIN.	MAX.	
a	22.70	24.15	
ØD	7.50	7.90	
K	-	7.00	2 flats
ØN	3.15	3.35	Note 1

NOTES

1. Shall accept cables specified in the table below.

ELECTRICAL CHARACTERISTICS	VALUES	UNITS
Frequency range	0 to 12.4	GHz
Maximum voltage standing wave ratio (VSWR)	$1.05 + 0.015 f$ (GHz)	
Maximum reflection coefficient	$0.047 + 0.0063 f$ (GHz)	
Maximum insertion loss	$0.03\sqrt{f}$ (GHz)	dB
RF leakage	$-[95 - f]$ (GHz)	dB
Voltage proof	750	Vrms
Corona level	190	Vrms

MECHANICAL CHARACTERISTICS	VALUES	UNITS
Mini centre contact retention force (axial)	27	N
Mini centre contact retention torque	0.5	N.cm
Mini cable retention force	90	N
Mini cable retention torque value	$2 \times 180^\circ$ applic. point $50 \times \text{ØN}$	
Maximum weight	4.5	g

OTHER CHARACTERISTICS	VALUES	UNITS
Rapid change of temperature - peak value	+ 200 (see cables used)	°C
Operating temperature range	- 65 to + 165	°C
Maxi leakage (panel sealed connectors)	Not applicable	
Maxi leakage (hermetic sealed connector)	Not applicable	
Solderability	Applicable	
Soldering proof	Not applicable	
Cables used	KX 3B, KX 22A RG 174/U, RG 316/U	

FIGURE 2(b) - VARIANTS (CONTINUED)

VARIANT 07 - STRAIGHT JACK, CRIMP-TYPE, FOR CABLE \varnothing 5mm/50 Ω , SINGLE BRAID

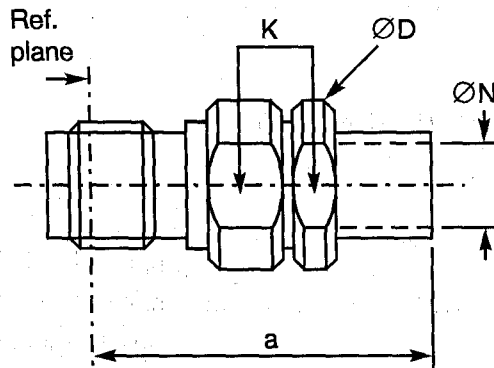

SYMBOL	MILLIMETRES		NOTES
	MIN.	MAX.	
a	24.90	26.15	2 flats
ØD	7.50	7.90	
K	-	7.00	
ØN	5.55	5.65	

ELECTRICAL CHARACTERISTICS	VALUES	UNITS
Frequency range	0 to 12.4	GHz
Maximum voltage standing wave ratio (VSWR)	$1.15 + 0.01 f$ (GHz)	
Maximum reflection coefficient	$0.070 + 0.004 f$ (GHz)	
Maximum insertion loss	$0.03 \sqrt{f}$ (GHz)	dB
RF leakage	$- [95 - f]$ (GHz)	dB
Voltage proof	1000	Vrms
Corona level	250	Vrms

MECHANICAL CHARACTERISTICS	VALUES	UNITS
Mini centre contact retention force (axial)	27	N
Mini centre contact retention torque	0.5	N.cm
Mini cable retention force	180	N
Mini cable retention torque value	$2 \times 180^\circ$ applic. point $50 \times \varnothing N$	
Maximum weight	5.1	g

OTHER CHARACTERISTICS	VALUES	UNITS
Rapid change of temperature - peak value	+ 200 (see cables used)	$^\circ\text{C}$
Operating temperature range	- 65 to + 165 (see cables used)	$^\circ\text{C}$
Maxi leakage (panel sealed connectors)	Not applicable	
Maxi leakage (hermetic sealed connector)	Not applicable	
Solderability	Applicable	
Soldering proof	Not applicable	
Cables used	KX 15, RG 58 C/U, RG 141 A/U	

FIGURE 2(b) - VARIANTS (CONTINUED)

VARIANT 08 - STRAIGHT JACK, CRIMP-TYPE, FOR CABLE Ø 5mm/50Ω, DOUBLE BRAID

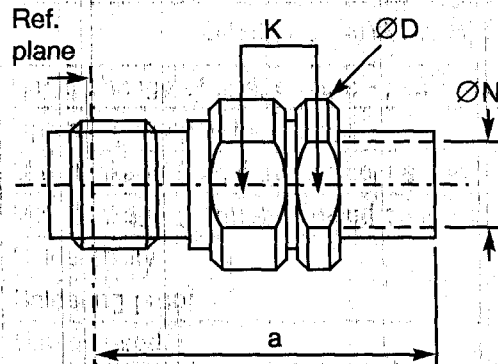

SYMBOL	MILLIMETRES		NOTES
	MIN.	MAX.	
a	24.90	26.15	
ØD	7.50	7.90	
K	-	7.00	2 flats
ØN	5.55	5.65	

ELECTRICAL CHARACTERISTICS	VALUES	UNITS
Frequency range	0 to 12.4	GHz
Maximum voltage standing wave ratio (VSWR)	$1.15 + 0.01 f$ (GHz)	
Maximum reflection coefficient	$0.070 + 0.004 f$ (GHz)	
Maximum insertion loss	$0.03 \sqrt{f}$ (GHz)	dB
RF leakage	$- [95 - f]$ (GHz)	dB
Voltage proof	1000	Vrms
Corona level	250	Vrms

MECHANICAL CHARACTERISTICS	VALUES	UNITS
Mini centre contact retention force (axial)	27	N
Mini centre contact retention torque	0.5	N.cm
Mini cable retention force	180	N
Mini cable retention torque value	$2 \times 180^\circ$ applic. point $50 \times \text{ØN}$	
Maximum weight	5.1	g

OTHER CHARACTERISTICS	VALUES	UNITS
Rapid change of temperature - peak value	+200 (see cables used)	°C
Operating temperature range	-65 to +165	°C
Maxi leakage (panel sealed connectors)	Not applicable	
Maxi leakage (hermetic sealed connector)	Not applicable	
Solderability	Applicable	
Soldering proof	Not applicable	
Cables used	KX 23, RG 142 B/U, RG 223/U	

FIGURE 2(b) - VARIANTS (CONTINUED)

VARIANT 09 - STRAIGHT JACK, SOLDER TYPE, BACK MOUNTING, 2-HOLE, FLANGE-MOUNTED, FOR SEMI-RIGID CABLE Ø2.20mm (0.085")

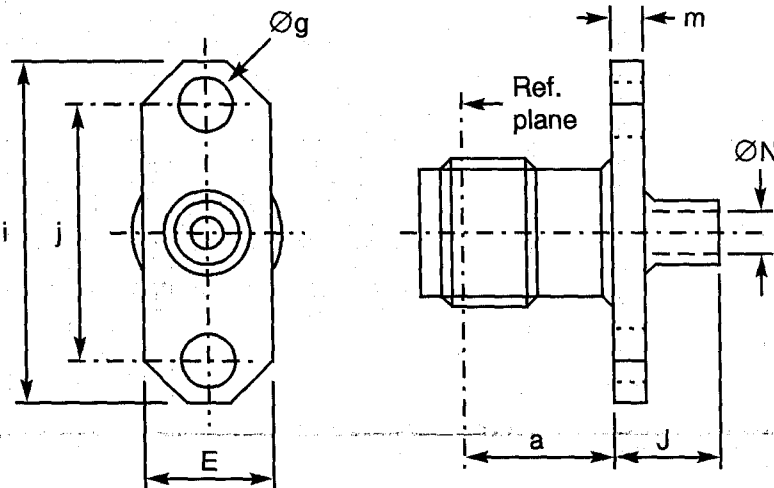

SYMBOL	MILLIMETRES		NOTES
	MIN.	MAX.	
a	5.87	6.12	2 holes
E	5.50	5.80	
Øg	2.55	2.70	
i	15.90	16.10	
j	12.10	12.30	
J	4.60	5.00	
m	1.40	1.80	
ØN	2.25	2.35	

NOTES

1. Maximum panel thickness: 2.30mm.

ELECTRICAL CHARACTERISTICS	VALUES	UNITS
Frequency range	0 to 18	GHz
Maximum voltage standing wave ratio (VSWR)	$1.10 + 0.01 f$ (GHz)	
Maximum reflection coefficient	$0.047 + 0.004 f$ (GHz)	
Maximum insertion loss	$0.02\sqrt{f}$ (GHz)	dB
RF leakage	$- [100 - f$ (GHz)]	dB
Voltage proof	750	Vrms
Corona level	190	Vrms

MECHANICAL CHARACTERISTICS	VALUES	UNITS
Mini centre contact retention force (axial)	Not applicable	N
Mini centre contact retention torque	Not applicable	N.cm
Mini cable retention force	200	N
Mini cable retention torque value	11.5	N.cm
Maximum weight	3.0	g

OTHER CHARACTERISTICS	VALUES	UNITS
Rapid change of temperature - peak value	+200	°C
Operating temperature range	-65 to +165	°C
Maxi leakage (panel sealed connectors)	Not applicable	
Maxi leakage (hermetic sealed connector)	Not applicable	
Solderability	Applicable	
Soldering proof	Not applicable	
Cables used	KS 1, RG 405/U (Ø2.20mm)	

FIGURE 2(b) - VARIANTS (CONTINUED)

**VARIANT 10 - STRAIGHT JACK, SOLDER TYPE, BACK MOUNTING, 2-HOLE, FLANGE-MOUNTED,
FOR SEMI-RIGID CABLE Ø3.58mm (0.141")**

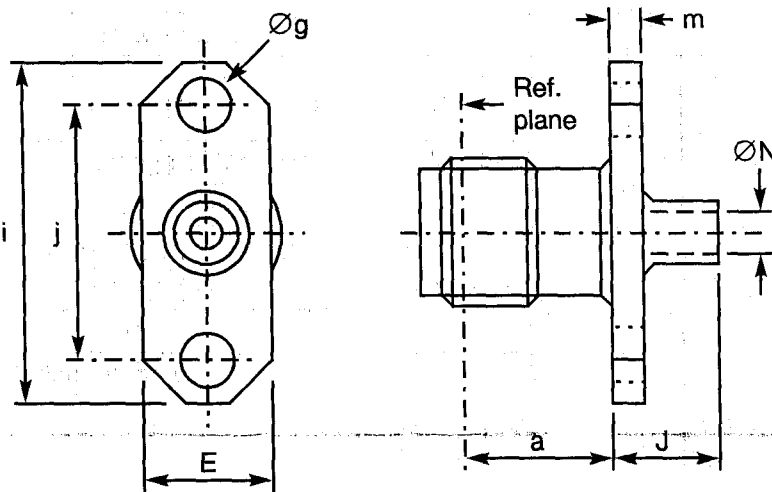

SYMBOL	MILLIMETRES		NOTES
	MIN.	MAX.	
a	5.87	6.12	2 holes
E	5.50	5.80	
Øg	2.55	2.70	
i	15.90	16.10	
j	12.10	12.30	
J	4.60	5.00	
m	1.40	1.80	
ØN	3.65	3.75	

NOTES

1. Maximum panel thickness: 2.30mm.

ELECTRICAL CHARACTERISTICS	VALUES	UNITS
Frequency range	0 to 18	GHz
Maximum voltage standing wave ratio (VSWR)	$1.05 + 0.04 f$ (GHz)	
Maximum reflection coefficient	$0.024 + 0.0018 f$ (GHz)	
Maximum insertion loss	$0.02\sqrt{f}$ (GHz)	dB
RF leakage	$-[100 - f]$ (GHz)	dB
Voltage proof	1000	V _{rms}
Corona level	250	V _{rms}

MECHANICAL CHARACTERISTICS	VALUES	UNITS
Mini centre contact retention force (axial)	Not applicable	N
Mini centre contact retention torque	Not applicable	N.cm
Mini cable retention force	500	N
Mini cable retention torque value	39.6	N.cm
Maximum weight	3.0	g

OTHER CHARACTERISTICS	VALUES	UNITS
Rapid change of temperature - peak value	+200	°C
Operating temperature range	-65 to +165	°C
Maxi leakage (panel sealed connectors)	Not applicable	
Maxi leakage (hermetic sealed connector)	Not applicable	
Solderability	Applicable	
Soldering proof	Not applicable	
Cables used	KS 2, RG 402/U (Ø3.58mm)	

FIGURE 2(b) - VARIANTS (CONTINUED)

VARIANT 11 - STRAIGHT JACK, CRIMP-TYPE, SQUARE FLANGE

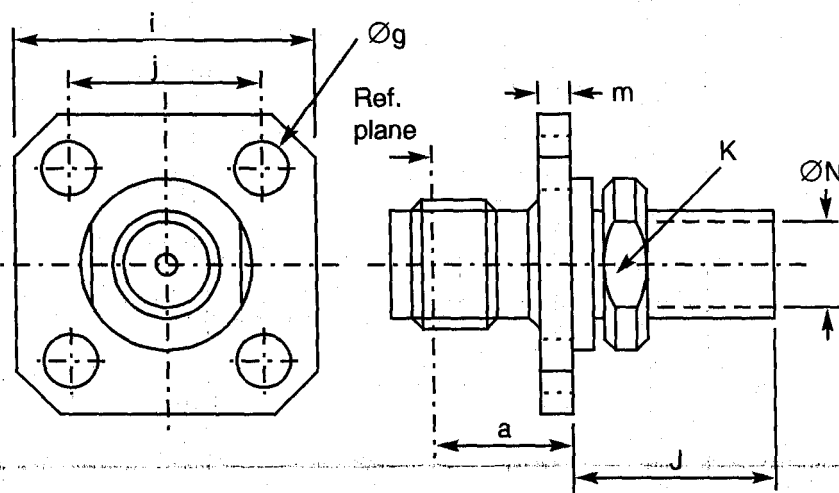

SYMBOL	MILLIMETRES		NOTES
	MIN.	MAX.	
a	7.40	7.75	4 holes
Øg	2.55	2.70	
i	12.60	12.80	
j	8.59	8.69	
J	15.10	17.60	2 flats
K	-	7.00	
m	1.40	1.80	
ØN	3.25	3.35	

ELECTRICAL CHARACTERISTICS	VALUES	UNITS
Frequency range	0 to 12.4	GHz
Maximum voltage standing wave ratio (VSWR)	$1.10 + 0.015 f$ (GHz)	
Maximum reflection coefficient	$0.047 + 0.0063 f$ (GHz)	
Maximum insertion loss	$0.03 \sqrt{f}$ (GHz)	dB
RF leakage	$-[95 - f]$ (GHz)	dB
Voltage proof	750	Vrms
Corona level	190	Vrms

MECHANICAL CHARACTERISTICS	VALUES	UNITS
Mini centre contact retention force (axial)	27	N
Mini centre contact retention torque	0.5	N.cm
Mini cable retention force	90	N
Mini cable retention torque value	$2 \times 180^\circ$ applic. point $50 \times \text{ØN}$	
Maximum weight	5.2	g

OTHER CHARACTERISTICS	VALUES	UNITS
Rapid change of temperature - peak value	+200 (see cables used)	°C
Operating temperature range	-65 to +165	°C
Maxi leakage (panel sealed connectors)	Not applicable	
Maxi leakage (hermetic sealed connector)	Not applicable	
Solderability	Applicable	
Soldering proof	Not applicable	
Cables used	KX 3B, KX 22A, RG 174/U, RG 316/U	

FIGURE 2(b) - VARIANTS (CONTINUED)

VARIANT 12 - STRAIGHT JACK, CRIMP-TYPE, SQUARE FLANGE

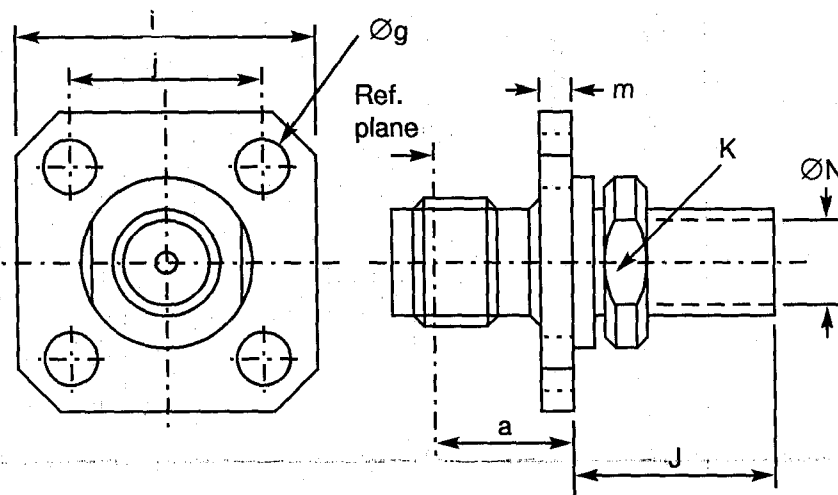

SYMBOL	MILLIMETRES		NOTES
	MIN.	MAX.	
a	7.40	7.75	
Øg	2.55	2.70	4 holes
i	12.60	12.80	
j	8.59	8.69	
J	15.10	17.60	
K	-	7.00	2 flats
m	1.40	1.80	
ØN	2.00	2.20	

ELECTRICAL CHARACTERISTICS	VALUES	UNITS
Frequency range	0 to 12.4	GHz
Maximum voltage standing wave ratio (VSWR)	$1.10 + 0.015 f$ (GHz)	
Maximum reflection coefficient	$0.047 + 0.0063 f$ (GHz)	
Maximum insertion loss	$0.03 \sqrt{f}$ (GHz)	dB
RF leakage	$- [95 - f]$ (GHz)	dB
Voltage proof	750	V _{rms}
Corona level	190	V _{rms}

MECHANICAL CHARACTERISTICS	VALUES	UNITS
Mini centre contact retention force (axial)	27	N
Mini centre contact retention torque	0.5	N.cm
Mini cable retention force	80	N
Mini cable retention torque value	$2 \times 180^\circ$ applic. point $50 \times \text{ØN}$	
Maximum weight	4.4	g

OTHER CHARACTERISTICS	VALUES	UNITS
Rapid change of temperature - peak value	+200 (see cables used)	°C
Operating temperature range	-65 to +165	°C
Maxi leakage (panel sealed connectors)	Not applicable	
Maxi leakage (hermetic sealed connector)	Not applicable	
Solderability	Applicable	
Soldering proof	Not applicable	
Cables used	50 CIS	

FIGURE 2(b) - VARIANTS (CONTINUED)

VARIANT 13 - STRAIGHT JACK, CRIMP- OR SOLDER-TYPE, SQUARE FLANGE

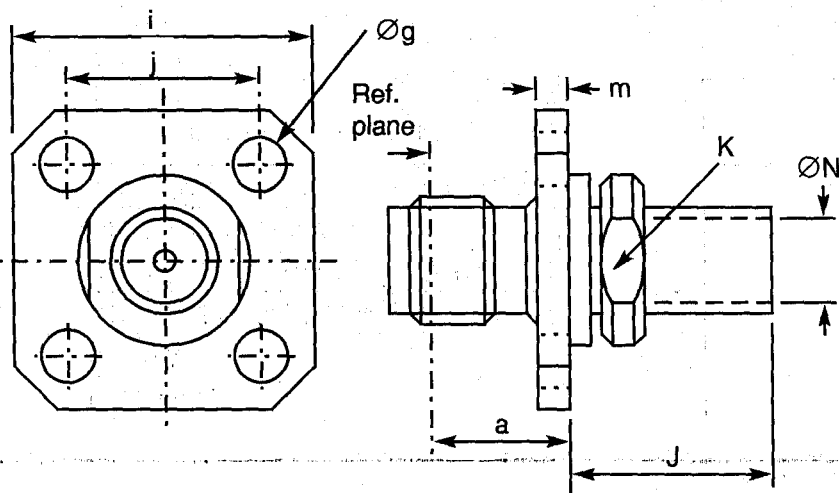

SYMBOL	MILLIMETRES		NOTES
	MIN.	MAX.	
a	7.40	7.75	
Øg	2.55	2.70	4 holes
i	12.60	12.80	
j	8.59	8.69	
J	17.10	20.40	
K	-	7.00	2 flats
m	1.40	1.80	
ØN	5.55	5.65	

ELECTRICAL CHARACTERISTICS	VALUES	UNITS
Frequency range	0 to 12.4	GHz
Maximum voltage standing wave ratio (VSWR)	$1.10 + 0.012 f$ (GHz)	
Maximum reflection coefficient	$0.047 + 0.0049 f$ (GHz)	
Maximum insertion loss	$0.03 \sqrt{f}$ (GHz)	dB
RF leakage	$-[95 - f]$ (GHz)	dB
Voltage proof	1000	Vrms
Corona level	250	Vrms

MECHANICAL CHARACTERISTICS	VALUES	UNITS
Mini centre contact retention force (axial)	27	N
Mini centre contact retention torque	0.5	N.cm
Mini cable retention force	180	N
Mini cable retention torque value	$2 \times 180^\circ$ applic. point $50 \times \text{ØN}$	
Maximum weight	5.8	g

OTHER CHARACTERISTICS	VALUES	UNITS
Rapid change of temperature - peak value	+200 (see cables used)	°C
Operating temperature range	-65 to +165	°C
Maxi leakage (panel sealed connectors)	Not applicable	
Maxi leakage (hermetic sealed connector)	Not applicable	
Solderability	Applicable	
Soldering proof	Not applicable	
Cables used	KX 15, RG 58C/U, RG 141A/U	

FIGURE 2(b) - VARIANTS (CONTINUED)

VARIANT 14 - STRAIGHT JACK, CRIMP- OR SOLDER-TYPE, SQUARE FLANGE, DOUBLE BRAID CABLE

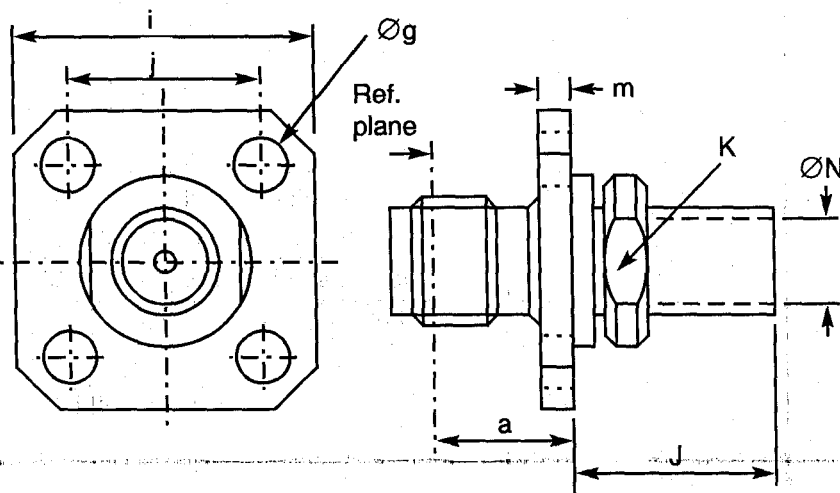

SYMBOL	MILLIMETRES		NOTES
	MIN.	MAX.	
a	7.40	7.75	4 holes
Øg	2.55	2.70	
i	12.60	12.80	
j	8.59	8.69	
J	17.10	20.40	2 flats
K	-	7.00	
m	1.40	1.80	
ØN	5.55	5.65	

ELECTRICAL CHARACTERISTICS	VALUES	UNITS
Frequency range	0 to 12.4	GHz
Maximum voltage standing wave ratio (VSWR)	1.10 + 0.012 f (GHz)	
Maximum reflection coefficient	0.047 + 0.0049 f (GHz)	
Maximum insertion loss	0.03√f (GHz)	dB
RF leakage	- [95 - f (GHz)]	dB
Voltage proof	1000	Vrms
Corona level	250	Vrms

MECHANICAL CHARACTERISTICS	VALUES	UNITS
Mini centre contact retention force (axial)	27	N
Mini centre contact retention torque	0.5	N.cm
Mini cable retention force	180	N
Mini cable retention torque value	2 × 180° applic. point 50 × Ø	
Maximum weight	5.5	g

OTHER CHARACTERISTICS	VALUES	UNITS
Rapid change of temperature - peak value	+ 200 (see cables used)	°C
Operating temperature range	- 65 to + 165	°C
Maxi leakage (panel sealed connectors)	Not applicable	
Maxi leakage (hermetic sealed connector)	Not applicable	
Solderability	Applicable	
Soldering proof	Applicable	
Cables used	KX 23, RG 142B/U, RG 223/U	

FIGURE 2(b) - VARIANTS (CONTINUED)

VARIANT 15 - SQUARE FLANGE RECEPTACLE, FRONT MOUNTING

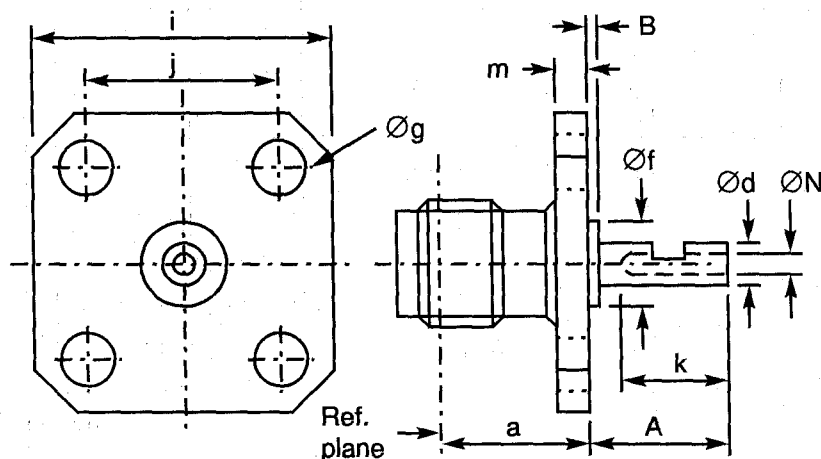

Solder Bucket -
Optional Shapes:



SYMBOL	MILLIMETRES		NOTES
	MIN.	MAX.	
a	7.50	7.70	
A	-	35.00	Note 1
B	-	20.00	Note 1
Ød	1.24	1.30	
Øf	4.00	4.20	
Øg	2.55	2.70	4 holes
i	12.60	12.80	
j	8.59	8.69	
k	2.40	-	
m	1.40	1.80	
ØN	0.70	1.00	

ELECTRICAL CHARACTERISTICS	VALUES	UNITS
Frequency range	0 to 18	GHz
Maximum voltage standing wave ratio (VSWR) (2)	$1.05 + 0.003 f$ (GHz)	
Maximum reflection coefficient (2)	$0.024 + 0.0013 f$ (GHz)	
Maximum insertion loss (2)	$0.03 \sqrt{f}$ (GHz)	dB
RF leakage (2)	$- [95 - f]$ (GHz)	dB
Voltage proof	1000	Vrms
Corona level	Not applicable	Vrms

NOTES

1. To specify dimensions, see Para. 4.5.3.
2. For information only.

MECHANICAL CHARACTERISTICS	VALUES	UNITS
Mini centre contact retention force (axial)	27	N
Mini centre contact retention torque	2.8	N.cm
Mini cable retention force	Not applicable	N
Mini cable retention torque value	Not applicable	N.cm
Maximum weight	2.7	g

OTHER CHARACTERISTICS	VALUES	UNITS
Rapid change of temperature - peak value	+115	°C
Operating temperature range	-65 to +105	°C
Maxi leakage (panel sealed connectors)	Not applicable	
Maxi leakage (hermetic sealed connector)	Not applicable	
Solderability	On centre contact only	
Soldering proof	Applicable	
Cables used	Not applicable	

FIGURE 2(b) - VARIANTS (CONTINUED)

VARIANT 16 - 2-HOLE FLANGE RECEPTACLE FOR MICRO-STRIP, FRONT MOUNTING

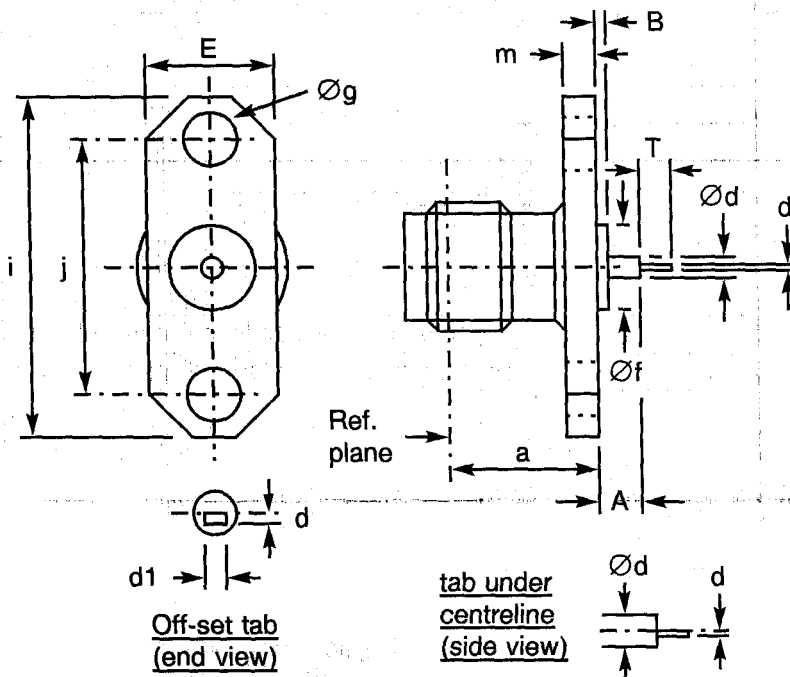

SYMBOL	MILLIMETRES		NOTES
	MIN.	MAX.	
a	7.50	7.60	
A	3.10	3.30	
B	0.15	0.35	
d	0.20	0.30	
Ød	0.70	0.90	
d1	0.40	0.50	
Øf	1.75	1.80	
E	5.50	5.80	
Øg	2.55	2.70	2 holes
i	15.90	16.10	
j	12.10	12.30	
m	1.40	1.80	
T	0.70	0.95	

ELECTRICAL CHARACTERISTICS		VALUES	UNITS
Frequency range		0 to 18	GHz
Maximum voltage standing wave ratio (VSWR)	(1)	$1.05 + 0.005 f$ (GHz)	
Maximum reflection coefficient	(1)	$0.024 + 0.0016 f$ (GHz)	
Maximum insertion loss	(1)	$0.03 \sqrt{f}$ (GHz)	dB
RF leakage	(1)	$-[95 - f]$ (GHz)	dB
Voltage proof		1000	Vrms
Corona level		Not applicable	Vrms

NOTES

1. For information only.

MECHANICAL CHARACTERISTICS		VALUES	UNITS
Mini centre contact retention force (axial)		27	N
Mini centre contact retention torque		2.8	N.cm
Mini cable retention force		Not applicable	N
Mini cable retention torque value		Not applicable	N.cm
Maximum weight		1.8	g

OTHER CHARACTERISTICS		VALUES	UNITS
Rapid change of temperature - peak value		+115	°C
Operating temperature range		-65 to +105	°C
Maxi leakage (panel sealed connectors)		Not applicable	
Maxi leakage (hermetic sealed connector)		Not applicable	
Solderability		On centre contact only	
Soldering proof		Applicable	
Cables used		Not applicable	

FIGURE 2(b) - VARIANTS (CONTINUED)

VARIANT 17 - 2-HOLE FLANGE RECEPTACLE, FRONT MOUNTING

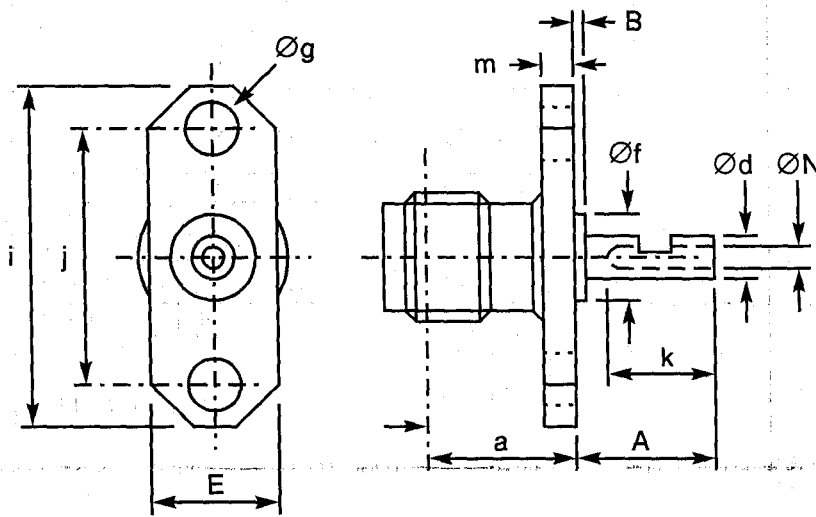

Solder Bucket -
Optional Shapes:

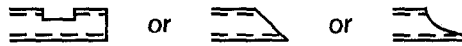

SYMBOL	MILLIMETRES		NOTES
	MIN.	MAX.	
a	7.50	7.70	
A	-	35.00	Note 1
B	-	20.00	Note 1
Ød	1.24	1.30	
E	5.50	5.80	
Øf	4.00	4.20	
Øg	2.55	2.70	2 holes
i	15.90	16.10	
j	12.10	12.30	
k	2.40	-	
m	1.40	1.80	
ØN	0.70	1.00	

ELECTRICAL CHARACTERISTICS		VALUES	UNITS
Frequency range		0 to 18	GHz
Maximum voltage standing wave ratio (VSWR)	(2)	$1.05 + 0.003 f$ (GHz)	
Maximum reflection coefficient	(2)	$0.047 + 0.0013 f$ (GHz)	
Maximum insertion loss	(2)	$0.03 \sqrt{f}$ (GHz)	dB
RF leakage	(2)	$- [95 - f$ (GHz)]	dB
Voltage proof		1000	Vrms
Corona level		Not applicable	Vrms

NOTES

- To specify dimensions, see Para. 4.5.3.
- For information only.

MECHANICAL CHARACTERISTICS		VALUES	UNITS
Mini centre contact retention force (axial)		27	N
Mini centre contact retention torque		2.8	N.cm
Mini cable retention force		Not applicable	N
Mini cable retention torque value		Not applicable	N.cm
Maximum weight		2.0	g

OTHER CHARACTERISTICS		VALUES	UNITS
Rapid change of temperature - peak value		+115	°C
Operating temperature range		-65 to +105	°C
Maxi leakage (panel sealed connectors)		Not applicable	
Maxi leakage (hermetic sealed connector)		Not applicable	
Solderability		On centre contact only	
Soldering proof		Applicable	
Cables used		Not applicable	

FIGURE 2(b) - VARIANTS (CONTINUED)

VARIANT 18 - 2-HOLE FLANGE RECEPTACLE FOR MICRO-STRIP, FRONT MOUNTING

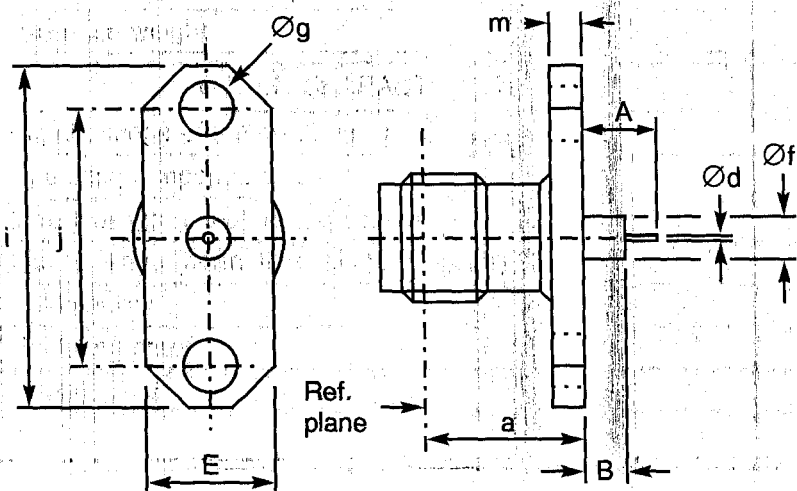

SYMBOL	MILLIMETRES		NOTES
	MIN.	MAX.	
a	7.50	7.60	
A	4.50	5.00	
B	3.05	3.30	
Ød	0.20	0.30	
E	5.50	5.80	
Øf	2.10	2.20	
Øg	2.55	2.70	2 holes
i	15.90	16.10	
j	12.10	12.30	
m	1.40	1.80	

ELECTRICAL CHARACTERISTICS		VALUES	UNITS
Frequency range		0 to 12.4	GHz
Maximum voltage standing wave ratio (VSWR)	(1)	$1.04 + 0.018 f$ (GHz)	
Maximum reflection coefficient	(1)	$0.019 + 0.0074 f$ (GHz)	
Maximum insertion loss	(1)	$0.03 \sqrt{f}$ (GHz)	dB
RF leakage	(1)	$- [95 - f$ (GHz)]	dB
Voltage proof		1000	Vrms
Corona level		Not applicable	Vrms

NOTES

1. For information only.

MECHANICAL CHARACTERISTICS		VALUES	UNITS
Mini centre contact retention force (axial)		27	N
Mini centre contact retention torque		2.8	N.cm
Mini cable retention force		Not applicable	N
Mini cable retention torque value		Not applicable	N.cm
Maximum weight		2.0	g

OTHER CHARACTERISTICS		VALUES	UNITS
Rapid change of temperature - peak value		+ 115	°C
Operating temperature range		- 65 to + 105	°C
Maxi leakage (panel sealed connectors)		Not applicable	
Maxi leakage (hermetic sealed connector)		Not applicable	
Solderability		On centre contact only	
Soldering proof		Applicable	
Cables used		Not applicable	

FIGURE 2(b) - VARIANTS (CONTINUED)

VARIANT 19 - SQUARE FLANGE RECEPTACLE FOR MICRO-STRIP, FRONT MOUNTING, OFF-SET TAB

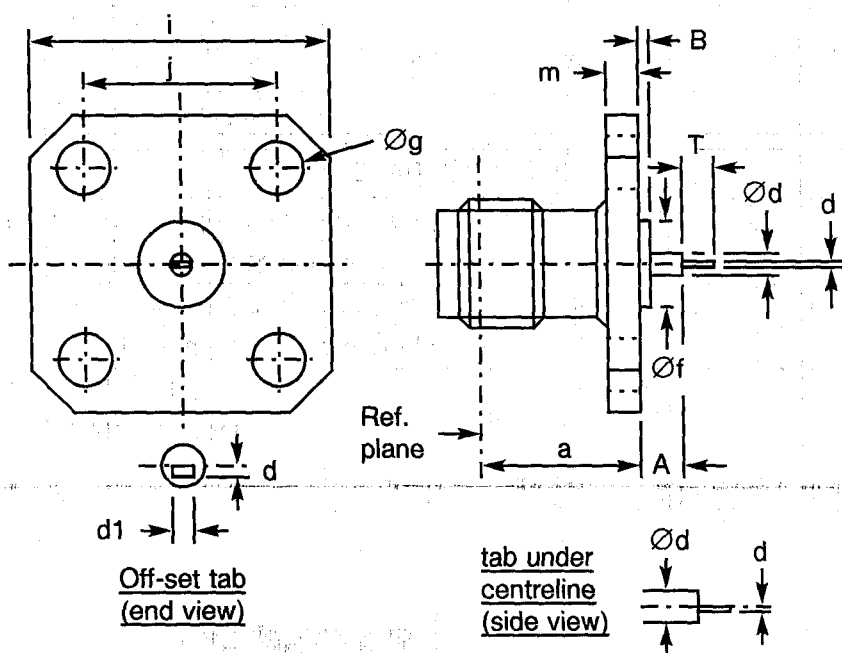

SYMBOL	MILLIMETRES		NOTES
	MIN.	MAX.	
a	7.50	7.70	
A	3.10	3.30	
B	0.15	0.35	
d	0.20	0.30	
Ød	0.70	0.90	
d1	0.40	0.50	
Øf	1.75	1.80	
Øg	2.55	2.70	4 holes
i	12.60	12.80	
j	8.59	8.69	
m	1.40	1.80	
T	0.70	0.95	

ELECTRICAL CHARACTERISTICS	VALUES	UNITS
Frequency range	0 to 18	GHz
Maximum voltage standing wave ratio (VSWR) (1)	1.05 + 0.05 f (GHz)	
Maximum reflection coefficient (1)	0.024 + 0.016 f (GHz)	
Maximum insertion loss (1)	0.03 √f (GHz)	dB
RF leakage (1)	- [95 - f (GHz)]	dB
Voltage proof	1000	Vrms
Corona level	Not applicable	Vrms

NOTES

1. For information only.

MECHANICAL CHARACTERISTICS	VALUES	UNITS
Mini centre contact retention force (axial)	27	N
Mini centre contact retention torque	2.8	N.cm
Mini cable retention force	Not applicable	N
Mini cable retention torque value	Not applicable	N.cm
Maximum weight	2.6	g

OTHER CHARACTERISTICS	VALUES	UNITS
Rapid change of temperature - peak value	+ 115	°C
Operating temperature range	- 65 to + 105	°C
Maxi leakage (panel sealed connectors)	Not applicable	
Maxi leakage (hermetic sealed connector)	Not applicable	
Solderability	On centre contact only	
Soldering proof	Applicable	
Cables used	Not applicable	

FIGURE 2(b) - VARIANTS (CONTINUED)

VARIANT 20 - 2-HOLE FLANGE RECEPTACLE FOR STRIP LINE, FRONT MOUNTING

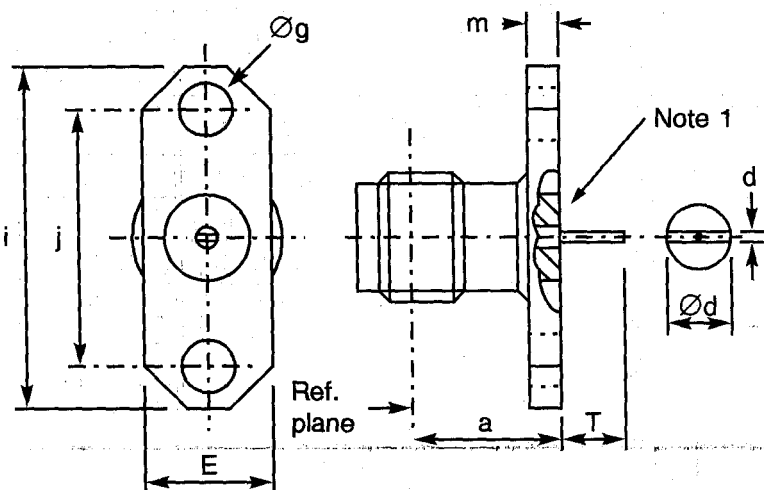

SYMBOL	MILLIMETRES		NOTES
	MIN.	MAX.	
a	7.50	7.70	Tab thickness
d	0.10	0.20	
Ød	1.24	1.30	2 holes
E	5.50	5.80	
Øg	2.55	2.70	
i	15.90	16.10	
j	12.10	12.30	
m	1.40	1.80	
T	2.35	2.70	

ELECTRICAL CHARACTERISTICS	VALUES	UNITS
Frequency range	0 to 18	GHz
Maximum voltage standing wave ratio (VSWR) (2)	$1.05 + 0.005 f$ (GHz)	
Maximum reflection coefficient (2)	$0.024 + 0.0023 f$ (GHz)	
Maximum insertion loss (2)	$0.03 \sqrt{f}$ (GHz)	dB
RF leakage (2)	$-[100 - f]$ (GHz)	dB
Voltage proof	1000	Vrms
Corona level	Not applicable	Vrms

NOTES

1. Insert may stand proud of, or be recessed from, the flange by 0.05mm.
2. For information only.

MECHANICAL CHARACTERISTICS	VALUES	UNITS
Mini centre contact retention force (axial)	Not applicable	N
Mini centre contact retention torque	Not applicable	N.cm
Mini cable retention force	Not applicable	N
Mini cable retention torque value	Not applicable	N.cm
Maximum weight	2.0	g

OTHER CHARACTERISTICS	VALUES	UNITS
Rapid change of temperature - peak value	+200	°C
Operating temperature range	-65 to +165	°C
Maxi leakage (panel sealed connectors)	Not applicable	
Maxi leakage (hermetic sealed connector)	Not applicable	
Solderability	On centre contact only	
Soldering proof	Not applicable	
Cables used	Not applicable	

FIGURE 2(b) - VARIANTS (CONTINUED)

VARIANT 21 - SQUARE FLANGE RECEPTACLE FOR STRIP LINE, FRONT MOUNTING

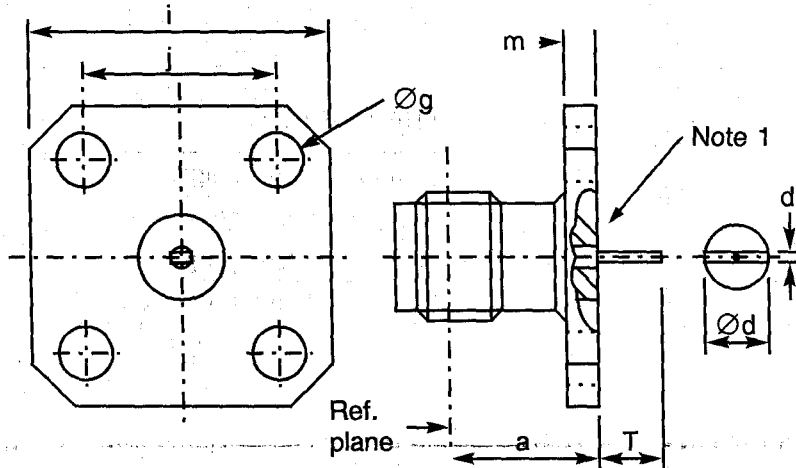

SYMBOL	MILLIMETRES		NOTES
	MIN.	MAX.	
a	7.50	7.70	Tab thickness
d	0.10	0.20	
Ød	1.24	1.30	4 holes
Øg	2.55	2.70	
i	12.60	12.80	
j	8.59	8.69	
m	1.40	1.80	
T	2.35	2.70	

ELECTRICAL CHARACTERISTICS	VALUES	UNITS
Frequency range	0 to 12.4	GHz
Maximum voltage standing wave ratio (VSWR) (2)	$1.05 + 0.005 f$ (GHz)	
Maximum reflection coefficient (2)	$0.024 + 0.0023 f$ (GHz)	
Maximum insertion loss (2)	$0.03 \sqrt{f}$ (GHz)	dB
RF leakage (2)	$- [90 - f$ (GHz)]	dB
Voltage proof	1000	Vrms
Corona level	Not applicable	Vrms

NOTES

1. Insert may stand proud of, or be recessed from, the flange by 0.05mm.
2. For information only.

MECHANICAL CHARACTERISTICS	VALUES	UNITS
Mini centre contact retention force (axial)	27	N
Mini centre contact retention torque	2.8	N.cm
Mini cable retention force	Not applicable	N
Mini cable retention torque value	Not applicable	N.cm
Maximum weight	2.7	g

OTHER CHARACTERISTICS	VALUES	UNITS
Rapid change of temperature - peak value	+115	°C
Operating temperature range	-65 to +105	°C
Maxi leakage (panel sealed connectors)	Not applicable	
Maxi leakage (hermetic sealed connector)	Not applicable	
Solderability	On centre contact only	
Soldering proof	Applicable	
Cables used	Not applicable	

FIGURE 2(b) - VARIANTS (CONTINUED)

VARIANT 22 - SQUARE FLANGE RECEPTACLE FOR MICRO-STRIP, FRONT MOUNTING

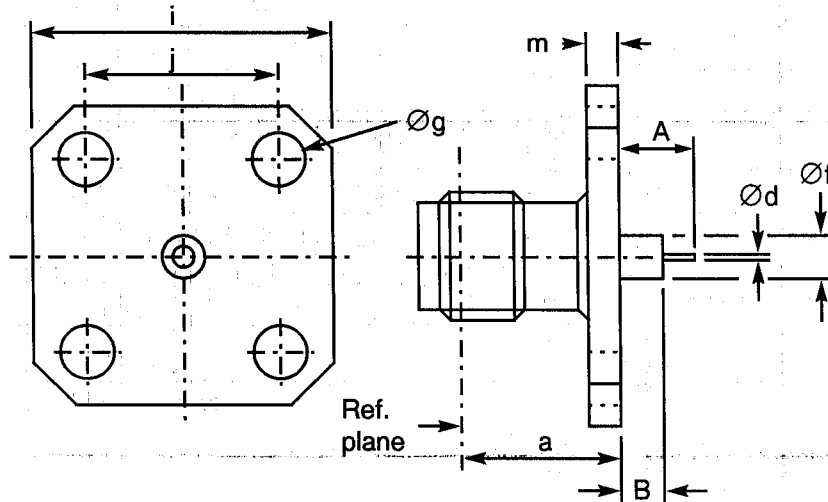

SYMBOL	MILLIMETRES		NOTES
	MIN.	MAX.	
a	7.50	7.60	4 holes
A	4.60	4.90	
B	3.05	3.30	
Ød	0.20	0.30	
Øf	2.10	2.20	
Øg	2.55	2.70	
i	12.60	12.80	
j	8.59	8.69	
m	1.40	1.80	

ELECTRICAL CHARACTERISTICS	VALUES	UNITS
Frequency range	0 to 12.4	GHz
Maximum voltage standing wave ratio (VSWR) (1)	$1.04 + 0.018 f$ (GHz)	
Maximum reflection coefficient (1)	$0.019 + 0.0074 f$ (GHz)	
Maximum insertion loss (1)	$0.03 \sqrt{f}$ (GHz)	dB
RF leakage (1)	$- [95 - f$ (GHz)]	dB
Voltage proof	1000	Vrms
Corona level	Not applicable	Vrms

NOTES

1. For information only.

MECHANICAL CHARACTERISTICS	VALUES	UNITS
Mini centre contact retention force (axial)	27	N
Mini centre contact retention torque	2.8	N.cm
Mini cable retention force	Not applicable	N
Mini cable retention torque value	Not applicable	N.cm
Maximum weight	2.6	g

OTHER CHARACTERISTICS	VALUES	UNITS
Rapid change of temperature - peak value	+ 115	°C
Operating temperature range	- 65 to + 105	°C
Maxi leakage (panel sealed connectors)	Not applicable	
Maxi leakage (hermetic sealed connector)	Not applicable	
Solderability	On centre contact only	
Soldering proof	Applicable	
Cables used	Not applicable	

FIGURE 2(b) - VARIANTS (CONTINUED)

VARIANT 23 - BULKHEAD RECEPTACLE

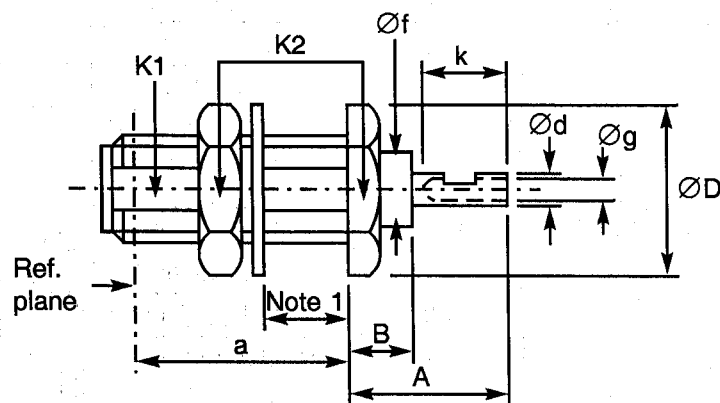

SYMBOL	MILLIMETRES		NOTES
	MIN.	MAX.	
a	9.40	9.85	
A	5.40	5.70	
B	2.60	3.15	
Ød	1.24	1.30	
ØD	-	9.10	
Øf	4.00	4.20	
Øg	0.75	-	
k	2.40	-	
K1	-	6.00	2 flats
K2	-	8.00	

Solder Bucket -
Optional Shapes:



ELECTRICAL CHARACTERISTICS	VALUES	UNITS
Frequency range	0 to 18	GHz
Maximum voltage standing wave ratio (VSWR) (2)	$1.05 + 0.06 f$ (GHz)	
Maximum reflection coefficient (2)	$0.024 + 0.018 f$ (GHz)	
Maximum insertion loss (2)	$0.03 \sqrt{f}$ (GHz)	dB
RF leakage (2)	$- [95 - f]$ (GHz)	dB
Voltage proof	1000	Vrms
Corona level	Not applicable	Vrms

NOTES

1. Maximum panel thickness: 3.40mm.
2. For information only.

MECHANICAL CHARACTERISTICS	VALUES	UNITS
Mini centre contact retention force (axial)	27	N
Mini centre contact retention torque	2.8	N.cm
Mini cable retention force	Not applicable	N
Mini cable retention torque value	Not applicable	N.cm
Maximum weight	2.6	g

OTHER CHARACTERISTICS	VALUES	UNITS
Rapid change of temperature - peak value	+115	°C
Operating temperature range	-65 to +105	°C
Maxi leakage (panel sealed connectors)	Not applicable	
Maxi leakage (hermetic sealed connector)	Not applicable	
Solderability	On centre contact only	
Soldering proof	Applicable	
Cables used	Not applicable	

FIGURE 2(b) - VARIANTS (CONTINUED)

VARIANT 24 - BULKHEAD RECEPTACLE WITH SEALING GASKET

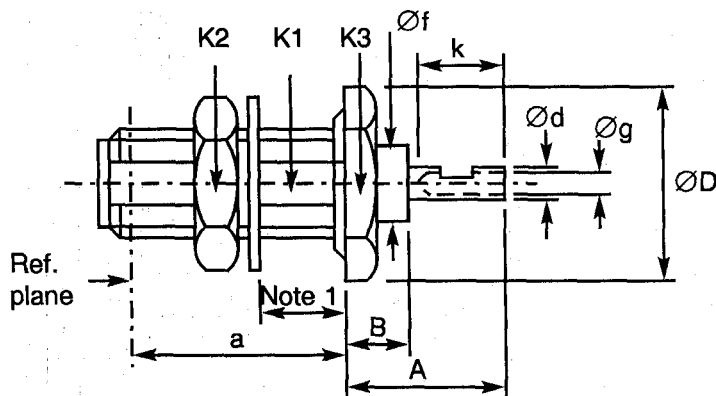

Solder Bucket -
Optional Shapes:



SYMBOL	MILLIMETRES		NOTES
	MIN.	MAX.	
a	10.90	11.30	
A	6.10	6.40	
B	2.80	3.00	
Ød	1.24	1.30	
ØD	-	12.50	
Øf	4.00	4.20	
Øg	0.80	-	
k	2.40	-	
K1	-	6.00	2 flats
K2	-	9.00	
K3	-	11.00	

ELECTRICAL CHARACTERISTICS	VALUES	UNITS
Frequency range	0 to 18	GHz
Maximum voltage standing wave ratio (VSWR) (2)	$1.05 + 0.06 f$ (GHz)	
Maximum reflection coefficient (2)	$0.024 + 0.018 f$ (GHz)	
Maximum insertion loss (2)	$0.03 \sqrt{f}$ (GHz)	dB
RF leakage (2)	- [95 - f (GHz)]	dB
Voltage proof	1000	Vrms
Corona level	Not applicable	Vrms

NOTES

1. Maximum panel thickness: 3.40mm.
2. For information only.

MECHANICAL CHARACTERISTICS	VALUES	UNITS
Mini centre contact retention force (axial)	27	N
Mini centre contact retention torque	2.8	N.cm
Mini cable retention force	Not applicable	N
Mini cable retention torque value	Not applicable	N.cm
Maximum weight	3.5	g

OTHER CHARACTERISTICS	VALUES	UNITS
Rapid change of temperature - peak value	+115	°C
Operating temperature range	-65 to +105	°C
Maxi leakage (panel sealed connectors)	Applicable	
Maxi leakage (hermetic sealed connector)	Not applicable	
Solderability	On centre contact only	
Soldering proof	Applicable	
Cables used	Not applicable	

FIGURE 2(b) - VARIANTS (CONTINUED)

VARIANT 25 - HERMETIC BULKHEAD RECEPTACLE

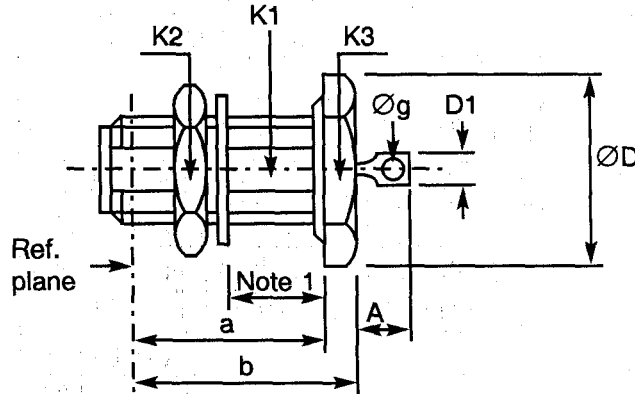

SYMBOL	MILLIMETRES		NOTES
	MIN.	MAX.	
a	10.50	10.85	
A	2.95	4.00	
b	12.90	13.25	
ØD	-	13.50	
D1	1.90	2.10	
Øg	1.00	-	
K1	-	6.00	1 flat
K2	-	9.00	Hex.
K3	-	12.00	Hex.

NOTES

1. Maximum panel thickness: 4.00mm.

ELECTRICAL CHARACTERISTICS	VALUES	UNITS
Frequency range	0 to 18	GHz
Maximum voltage standing wave ratio (VSWR)	Not applicable	
Maximum reflection coefficient	Not applicable	
Maximum insertion loss	Not applicable	dB
RF leakage	Not applicable	dB
Voltage proof	1000	Vrms
Corona level	Not applicable	Vrms

MECHANICAL CHARACTERISTICS	VALUES	UNITS
Mini centre contact retention force (axial)	27	N
Mini centre contact retention torque	2.8	N.cm
Mini cable retention force	Not applicable	N
Mini cable retention torque value	Not applicable	N.cm
Maximum weight	4.4	g

OTHER CHARACTERISTICS	VALUES	UNITS
Rapid change of temperature - peak value	+ 125	°C
Operating temperature range	- 40 to + 100	°C
Maxi leakage (panel sealed connectors)	Applicable	
Maxi leakage (hermetic sealed connector)	Applicable	
Solderability	On centre contact only	
Soldering proof	Applicable	
Cables used	Not applicable	

FIGURE 2(b) - VARIANTS (CONTINUED)

VARIANT 26 - HERMETIC RECEPTACLE, SOLDER TYPE

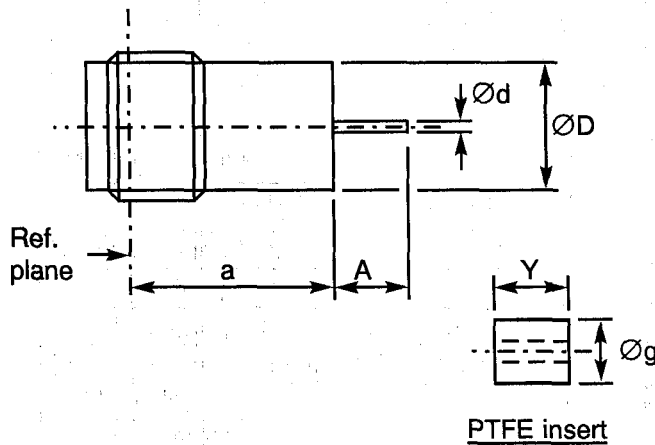

SYMBOL	MILLIMETRES	
	MIN.	MAX.
a	8.15	8.45
A	2.80	3.20
Ød	0.45	0.55
ØD	5.20	5.40
Øg	4.00	4.20
Y	6.25	6.30

ELECTRICAL CHARACTERISTICS	VALUES	UNITS
Frequency range	0 to 18	GHz
Maximum voltage standing wave ratio (VSWR)	(1) $1.05 + 0.015 f$ (GHz)	
Maximum reflection coefficient	(1) $0.024 + 0.0063 f$ (GHz)	
Maximum insertion loss	(1) $0.03 \sqrt{f}$ (GHz)	dB
RF leakage	(1) $- [95 - f]$ (GHz)	dB
Voltage proof	1000	Vrms
Corona level	Not applicable	Vrms

NOTES

1. For information only.

MECHANICAL CHARACTERISTICS	VALUES	UNITS
Mini centre contact retention force (axial)	Not applicable	N
Mini centre contact retention torque	Not applicable	N.cm
Mini cable retention force	Not applicable	N
Mini cable retention torque value	Not applicable	N.cm
Maximum weight	4.4	g

OTHER CHARACTERISTICS	VALUES	UNITS
Rapid change of temperature - peak value	Not applicable	°C
Operating temperature range	Not applicable	°C
Maxi leakage (panel sealed connectors)	Not applicable	
Maxi leakage (hermetic sealed connector)	Applicable	
Solderability	Applicable	
Soldering proof	Applicable	
Cables used	Not applicable	

FIGURE 2(b) - VARIANTS (CONTINUED)

VARIANT 27 - ELBOW RECEPTACLE, SQUARE FLANGE

Solder Bucket -
Optional Shapes:



or



or

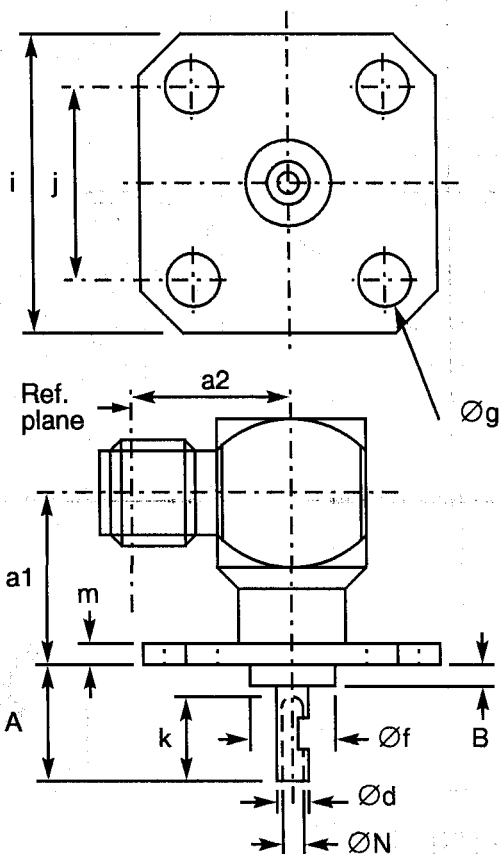
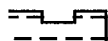

SYMBOL	MILLIMETRES		NOTES
	MIN.	MAX.	
a1	7.10	9.40	
a2	9.20	9.40	
A	4.25	4.75	
B	1.40	1.70	
Ød	1.25	1.30	
Øf	4.00	4.20	
Øg	2.55	2.70	4 holes
i	12.60	12.80	
j	8.59	8.69	
k	2.30	-	
m	1.40	1.80	
ØN	0.75	-	

NOTES

1. For information only.

ELECTRICAL CHARACTERISTICS		VALUES	UNITS
Frequency range		0 to 18	GHz
Maximum voltage standing wave ratio (VSWR)	(1)	$1.05 + 0.01 f$ (GHz)	
Maximum reflection coefficient	(1)	$0.024 + 0.004 f$ (GHz)	
Maximum insertion loss	(1)	$0.03 \sqrt{f}$ (GHz)	dB
RF leakage	(1)	$- [95 - f]$ (GHz)	dB
Voltage proof		1000	Vrms
Corona level		Not applicable	Vrms
MECHANICAL CHARACTERISTICS		VALUES	UNITS
Mini centre contact retention force (axial)		27	N
Mini centre contact retention torque		2.8	N.cm
Mini cable retention force		Not applicable	N
Mini cable retention torque value		Not applicable	N.cm
Maximum weight		5.2	g
OTHER CHARACTERISTICS		VALUES	UNITS
Rapid change of temperature - peak value		+200	°C
Operating temperature range		-65 to +165	°C
Maxi leakage (panel sealed connectors)		Not applicable	
Maxi leakage (hermetic sealed connector)		Not applicable	
Solderability		On centre contact only	
Soldering proof		Applicable	
Cables used		Not applicable	

FIGURE 2(b) - VARIANTS (CONTINUED)

VARIANT 28 - ELBOW RECEPTACLE, SQUARE FLANGE

Solder Bucket -
Optional Shapes:



or



or

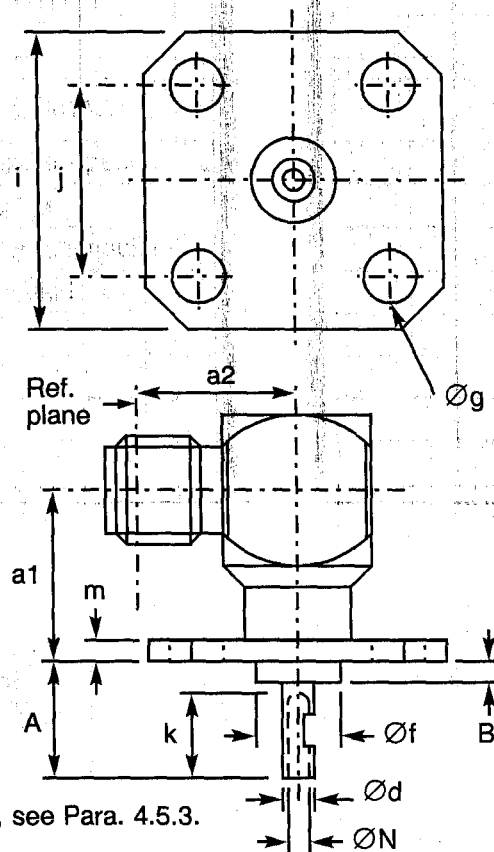

SYMBOL	MILLIMETRES		NOTES
	MIN.	MAX.	
a1	7.90	8.10	
a2	9.20	9.40	
A	-	15.00	Note 1
B	-	10.00	Note 1
Ød	1.25	1.30	
Øf	4.00	4.20	
Øg	2.55	2.70	4 holes
i	12.60	12.80	
j	8.59	8.69	
k	2.30	-	
m	1.40	1.80	
ØN	0.75	-	

NOTES

1. To specify dimensions, see Para. 4.5.3.
2. For information only.

ELECTRICAL CHARACTERISTICS		VALUES	UNITS
Frequency range		0 to 18	GHz
Maximum voltage standing wave ratio (VSWR) (2)		1.05 + 0.01 f (GHz)	
Maximum reflection coefficient (2)		0.024 + 0.004 f (GHz)	
Maximum insertion loss (2)		0.03 √f (GHz)	dB
RF leakage (2)		- [95 - f (GHz)]	dB
Voltage proof		1000	Vrms
Corona level		Not applicable	Vrms
MECHANICAL CHARACTERISTICS		VALUES	UNITS
Mini centre contact retention force (axial)		27	N
Mini centre contact retention torque		2.8	N.cm
Mini cable retention force		Not applicable	N
Mini cable retention torque value		Not applicable	N.cm
Maximum weight		5.5	g
OTHER CHARACTERISTICS		VALUES	UNITS
Rapid change of temperature - peak value		+ 115	°C
Operating temperature range		- 65 to + 105	°C
Maxi leakage (panel sealed connectors)		Not applicable	
Maxi leakage (hermetic sealed connector)		Not applicable	
Solderability		On centre contact only	
Soldering proof		Applicable	
Cables used		Not applicable	

FIGURE 2(b) - VARIANTS (CONTINUED)

VARIANT 29 - SQUARE FLANGE RECEPTACLE

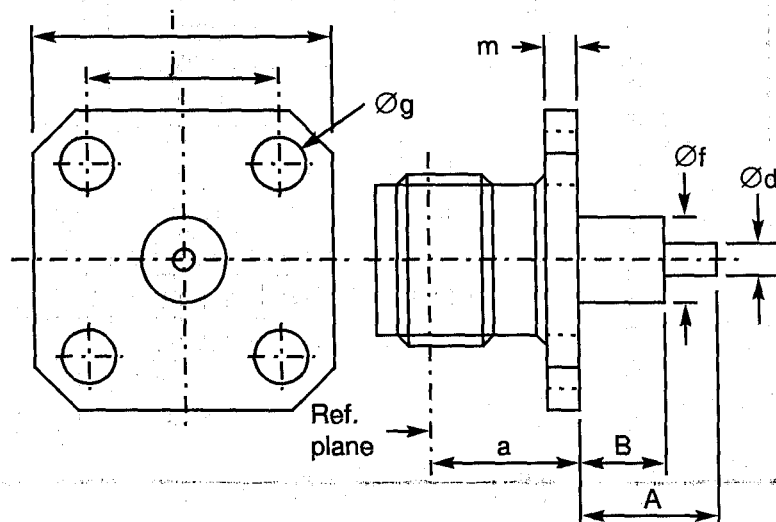

SYMBOL	MILLIMETRES		NOTES
	MIN.	MAX.	
a	7.50	7.70	
A	-	40.10	Note 1
B	-	20.00	Note 1
Ød	1.25	1.30	
Øf	4.00	4.20	
Øg	2.55	2.70	4 holes
i	12.60	12.80	
j	8.59	8.69	
m	1.40	1.80	

ELECTRICAL CHARACTERISTICS		VALUES	UNITS
Frequency range		0 to 18	GHz
Maximum voltage standing wave ratio (VSWR)	(2)	$1.05 + 0.003 f$ (GHz)	
Maximum reflection coefficient	(2)	$0.024 + 0.0013 f$ (GHz)	
Maximum insertion loss	(2)	$0.03 \sqrt{f}$ (GHz)	dB
RF leakage	(2)	$- [95 - f$ (GHz)]	dB
Voltage proof		1000	Vrms
Corona level		Not applicable	Vrms

NOTES

- To specify dimensions, see Para. 4.5.3.
- For information only.

MECHANICAL CHARACTERISTICS		VALUES	UNITS
Mini centre contact retention force (axial)		27	N
Mini centre contact retention torque		2.8	N.cm
Mini cable retention force		Not applicable	N
Mini cable retention torque value		Not applicable	N.cm
Maximum weight		4.1	g

OTHER CHARACTERISTICS		VALUES	UNITS
Rapid change of temperature - peak value		+ 115	°C
Operating temperature range		-65 to +105	°C
Maxi leakage (panel sealed connectors)		Not applicable	
Maxi leakage (hermetic sealed connector)		Not applicable	
Solderability		On centre contact only	
Soldering proof		Applicable	
Cables used		Not applicable	

FIGURE 2(b) - VARIANTS (CONTINUED)

VARIANT 30 - 2-HOLE FLANGE RECEPTACLE

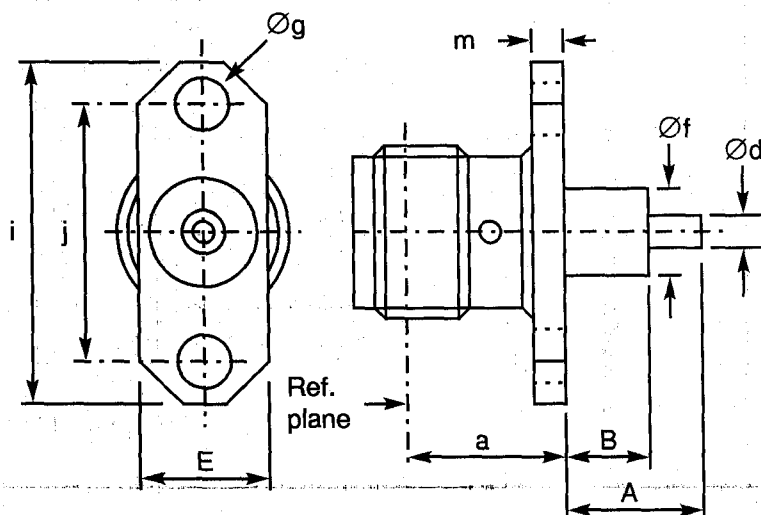

SYMBOL	MILLIMETRES		NOTES
	MIN.	MAX.	
a	7.50	7.60	
A	-	40.10	Note 1
B	-	20.00	Note 1
Ød	1.25	1.30	
E	5.50	5.80	
Øf	4.00	4.20	
Øg	2.55	2.70	2 holes
i	15.90	16.10	
j	12.10	12.30	
m	1.40	1.80	

ELECTRICAL CHARACTERISTICS	VALUES	UNITS
Frequency range	0 to 18	GHz
Maximum voltage standing wave ratio (VSWR) (2)	$1.05 + 0.003 f$ (GHz)	
Maximum reflection coefficient (2)	$0.024 + 0.0013 f$ (GHz)	
Maximum insertion loss (2)	$0.03 \sqrt{f}$ (GHz)	dB
RF leakage (2)	$- [95 - f$ (GHz)]	dB
Voltage proof	1000	Vrms
Corona level	Not applicable	Vrms

NOTES

- To specify dimensions, see Para. 4.5.3.
- For information only.

MECHANICAL CHARACTERISTICS	VALUES	UNITS
Mini centre contact retention force (axial)	27	N
Mini centre contact retention torque	2.8	N.cm
Mini cable retention force	Not applicable	N
Mini cable retention torque value	Not applicable	N.cm
Maximum weight	3.2	g

OTHER CHARACTERISTICS	VALUES	UNITS
Rapid change of temperature - peak value	+115	°C
Operating temperature range	-65 to +105	°C
Maxi leakage (panel sealed connectors)	Not applicable	
Maxi leakage (hermetic sealed connector)	Not applicable	
Solderability	On centre contact only	
Soldering proof	Applicable	
Cables used	Not applicable	

FIGURE 2(b) - VARIANTS (CONTINUED)

VARIANT 31 - SQUARE FLANGE RECEPTACLE

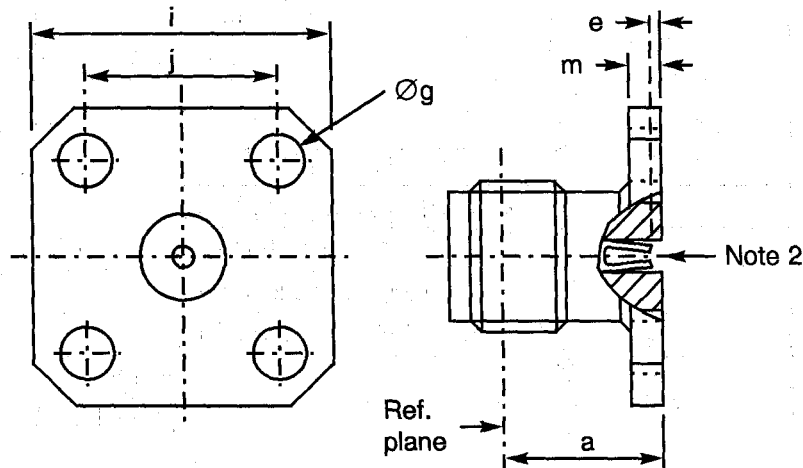

SYMBOL	MILLIMETRES		NOTES
	MIN.	MAX.	
a	7.50	7.70	4 holes
e	0.18	0.41	
Øg	2.55	2.70	
i	12.60	12.80	
j	8.59	8.69	
m	1.40	1.80	

ELECTRICAL CHARACTERISTICS	VALUES	UNITS
Frequency range	0 to 18	GHz
Maximum voltage standing wave ratio (VSWR)	$1.06 + 0.007 f$ (GHz)	
Maximum reflection coefficient	$0.029 + 0.0031 f$ (GHz)	
Maximum insertion loss (1)	$0.03\sqrt{f}$ (GHz)	dB
RF leakage (1)	$-[95 - f]$ (GHz)	dB
Voltage proof	1000	Vrms
Corona level	Not applicable	Vrms

NOTES

- For information only.
- Contact engagement and separation forces shall be measured on the rear contact (see Para. 4.3.8).

MECHANICAL CHARACTERISTICS	VALUES	UNITS
Mini centre contact retention force (axial)	27	N
Mini centre contact retention torque	Not applicable	N.cm
Mini cable retention force	Not applicable	N
Mini cable retention torque value	Not applicable	N.cm
Maximum weight	2.6	g

OTHER CHARACTERISTICS	VALUES	UNITS
Rapid change of temperature - peak value	+115	°C
Operating temperature range	-65 to +105	°C
Maxi leakage (panel sealed connectors)	Not applicable	
Maxi leakage (hermetic sealed connector)	Not applicable	
Solderability	Not applicable	
Soldering proof	Not applicable	
Cables used	Not applicable	

FIGURE 2(b) - VARIANTS (CONTINUED)

VARIANT 32 - 2-HOLE FLANGE RECEPTACLE

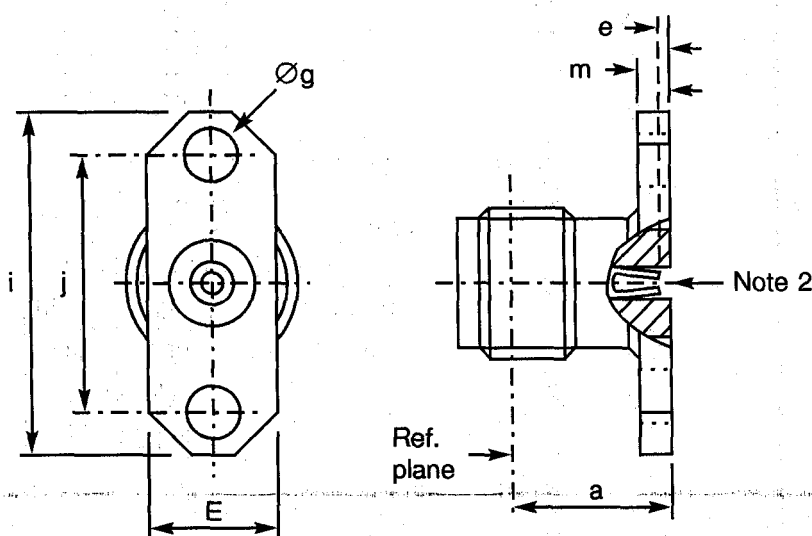

SYMBOL	MILLIMETRES		NOTES
	MIN.	MAX.	
a	7.50	7.60	2 holes
e	0.18	0.41	
E	5.50	5.80	
Øg	2.55	2.70	
i	15.90	16.10	
j	12.10	12.30	
m	1.40	1.80	

ELECTRICAL CHARACTERISTICS	VALUES	UNITS
Frequency range	0 to 18	GHz
Maximum voltage standing wave ratio (VSWR)	$1.06 + 0.006 f$ (GHz)	
Maximum reflection coefficient	$0.029 + 0.0026 f$ (GHz)	
Maximum insertion loss (1)	$0.03 \sqrt{f}$ (GHz)	dB
RF leakage (1)	$- [95 - f$ (GHz)]	dB
Voltage proof	1000	V _{rms}
Corona level	Not applicable	V _{rms}

NOTES

1. For information only.
2. Contact engagement and separation forces shall be measured on the rear contact (see Para. 4.3.8).

MECHANICAL CHARACTERISTICS	VALUES	UNITS
Mini centre contact retention force (axial)	27	N
Mini centre contact retention torque	2.8	N.cm
Mini cable retention force	Not applicable	N
Mini cable retention torque value	Not applicable	N.cm
Maximum weight	2.0	g

OTHER CHARACTERISTICS	VALUES	UNITS
Rapid change of temperature - peak value	+115	°C
Operating temperature range	-65 to +105	°C
Maxi leakage (panel sealed connectors)	Not applicable	
Maxi leakage (hermetic sealed connector)	Not applicable	
Solderability	Not applicable	
Soldering proof	Not applicable	
Cables used	Not applicable	

FIGURE 2(b) - VARIANTS (CONTINUED)

VARIANT 34 - FLANGE RECEPTACLE, TRIPLATE LAUNCHER

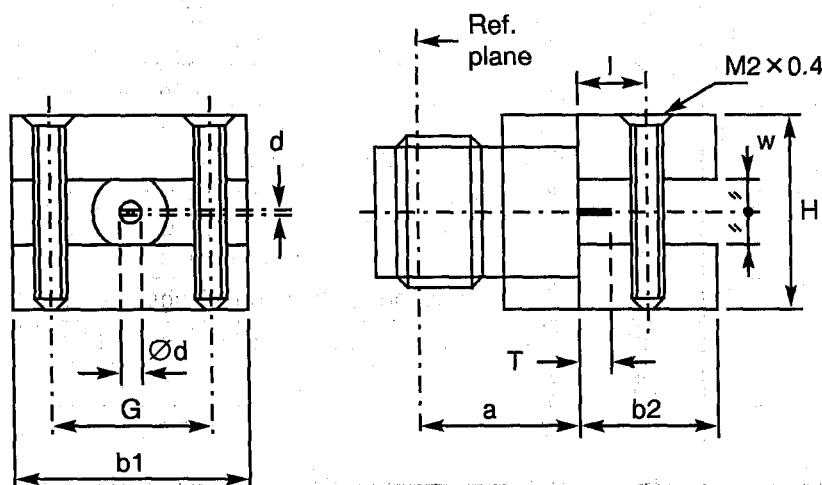

SYMBOL	MILLIMETRES	
	MIN.	MAX.
a	7.80	8.10
b1	13.80	14.10
b2	5.60	5.85
d	0.10	0.15
Ød	1.25	1.30
G	7.45	-
H	9.35	9.85
I	2.60	2.85
T	1.80	2.60
w	-	3.17

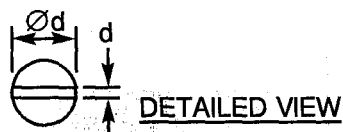

ELECTRICAL CHARACTERISTICS	VALUES	UNITS
Frequency range	0 to 4.0	GHz
Maximum voltage standing wave ratio (VSWR)	1.20	
Maximum reflection coefficient	0.0909	
Maximum insertion loss	Not applicable	dB
RF leakage	Not applicable	dB
Voltage proof	750	Vrms
Corona level	Not applicable	Vrms

MECHANICAL CHARACTERISTICS	VALUES	UNITS
Mini centre contact retention force (axial)	27	N
Mini centre contact retention torque	2.8	N.cm
Mini cable retention force	Not applicable	N
Mini cable retention torque value	Not applicable	N.cm
Maximum weight	15	g

OTHER CHARACTERISTICS	VALUES	UNITS
Rapid change of temperature - peak value	+ 115	°C
Operating temperature range	- 65 to + 105	°C
Maxi leakage (panel sealed connectors)	Not applicable	
Maxi leakage (hermetic sealed connector)	Not applicable	
Solderability	Not applicable	
Soldering proof	Not applicable	
Cables used	Not applicable	

FIGURE 2(b) - VARIANTS (CONTINUED)

VARIANT 36 - SQUARE FLANGE RECEPTACLE

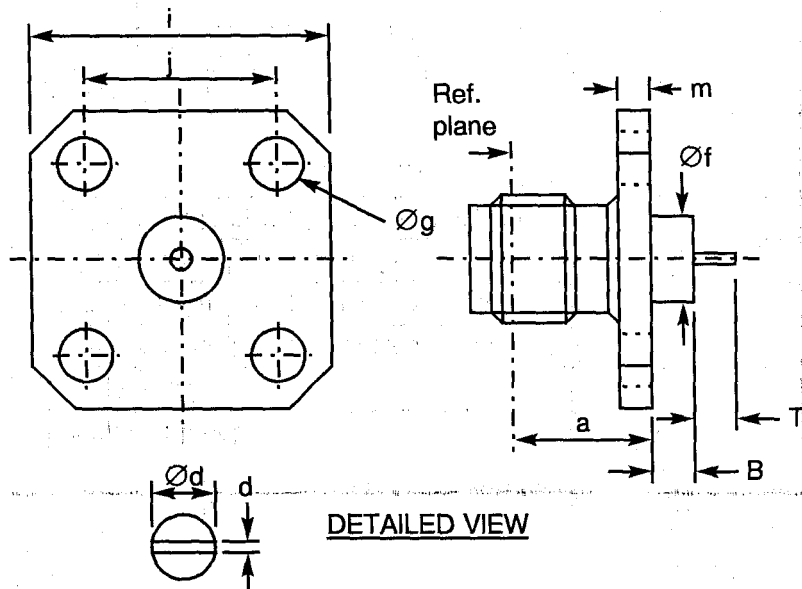

SYMBOL	MILLIMETRES		NOTES
	MIN.	MAX.	
a	7.50	7.70	4 holes
B	3.10	3.30	
d	0.10	0.35	
Ød	1.25	1.30	
Øf	4.00	4.20	
Øg	2.55	2.70	
i	12.60	12.80	
j	8.59	8.69	
m	1.40	1.80	
T	2.10	2.30	

ELECTRICAL CHARACTERISTICS	VALUES	UNITS
Frequency range	0 to 18	GHz
Maximum voltage standing wave ratio (VSWR) (1)	1.05 + 0.003 f (GHz)	
Maximum reflection coefficient (1)	0.024 + 0.0013 f (GHz)	
Maximum insertion loss (1)	0.03√f (GHz)	dB
RF leakage (1)	- [95 - f (GHz)]	dB
Voltage proof	1000	Vrms
Corona level	Not applicable	Vrms

NOTES

- For information only.

MECHANICAL CHARACTERISTICS	VALUES	UNITS
Mini centre contact retention force (axial)	27	N
Mini centre contact retention torque	2.8	N.cm
Mini cable retention force	Not applicable	N
Mini cable retention torque value	Not applicable	N.cm
Maximum weight	3.0	g

OTHER CHARACTERISTICS	VALUES	UNITS
Rapid change of temperature - peak value	+ 115	°C
Operating temperature range	- 65 to + 105	°C
Maxi leakage (panel sealed connectors)	Not applicable	
Maxi leakage (hermetic sealed connector)	Not applicable	
Solderability	On centre contact only	
Soldering proof	Applicable	
Cables used	Not applicable	

FIGURE 2(b) - VARIANTS (CONTINUED)

VARIANT 37 - FLANGE RECEPTACLE, TRIPLATE LAUNCHER

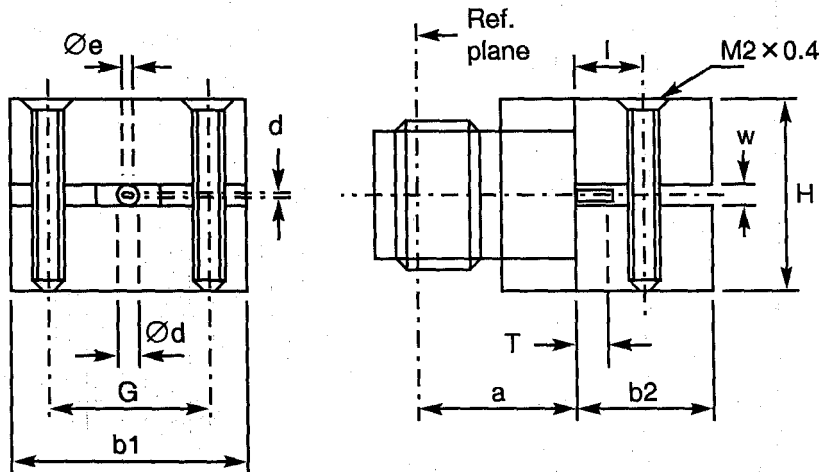

SYMBOL	MILLIMETRES	
	MIN.	MAX.
a	7.80	8.10
b1	13.90	14.10
b2	5.60	5.85
d	0.10	0.15
Ød	1.25	1.30
Øe	0.40	0.60
G	7.45	-
H	9.35	9.85
l	2.60	2.90
T	1.80	2.60
w	1.50	1.65

ELECTRICAL CHARACTERISTICS	VALUES	UNITS
Frequency range	0 to 8.0	GHz
Maximum voltage standing wave ratio (VSWR)	1.20	
Maximum reflection coefficient	0.0909	
Maximum insertion loss	Not applicable	dB
RF leakage	Not applicable	dB
Voltage proof	150	Vrms
Corona level	Not applicable	Vrms

MECHANICAL CHARACTERISTICS	VALUES	UNITS
Mini centre contact retention force (axial)	27	N
Mini centre contact retention torque	2.8	N.cm
Mini cable retention force	Not applicable	N
Mini cable retention torque value	Not applicable	N.cm
Maximum weight	15	g

OTHER CHARACTERISTICS	VALUES	UNITS
Rapid change of temperature - peak value	+115	°C
Operating temperature range	-65 to +105	°C
Maxi leakage (panel sealed connectors)	Not applicable	
Maxi leakage (hermetic sealed connector)	Not applicable	
Solderability	Not applicable	
Soldering proof	Not applicable	
Cables used	Not applicable	

FIGURE 2(b) - VARIANTS (CONTINUED)

VARIANT 38 - FLANGE RECEPTACLE, TRIPLATE LAUNCHER

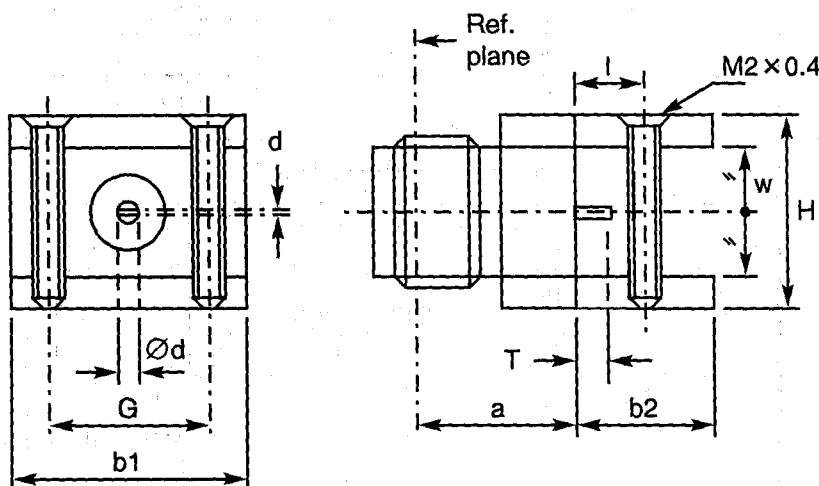

SYMBOL	MILLIMETRES	
	MIN.	MAX.
a	7.80	8.10
b1	13.90	14.10
b2	5.60	5.85
d	0.10	0.15
Ød	-	1.30
G	7.45	-
H	9.35	9.85
l	2.70	2.90
T	2.40	2.60
w	6.30	6.40

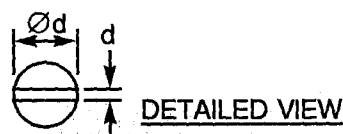

ELECTRICAL CHARACTERISTICS	VALUES	UNITS
Frequency range	0 to 2.0	GHz
Maximum voltage standing wave ratio (VSWR)	1.20	
Maximum reflection coefficient	0.0909	
Maximum insertion loss	Not applicable	dB
RF leakage	Not applicable	dB
Voltage proof	1000	Vrms
Corona level	Not applicable	Vrms

MECHANICAL CHARACTERISTICS	VALUES	UNITS
Mini centre contact retention force (axial)	27	N
Mini centre contact retention torque	2.8	N.cm
Mini cable retention force	Not applicable	N
Mini cable retention torque value	Not applicable	N.cm
Maximum weight	15	g

OTHER CHARACTERISTICS	VALUES	UNITS
Rapid change of temperature - peak value	+115	°C
Operating temperature range	-65 to +105	°C
Maxi leakage (panel sealed connectors)	Not applicable	
Maxi leakage (hermetic sealed connector)	Not applicable	
Solderability	Not applicable	
Soldering proof	Not applicable	
Cables used	Not applicable	

FIGURE 2(b) - VARIANTS (CONTINUED)

VARIANT 39 - SQUARE FLANGE RECEPTACLE

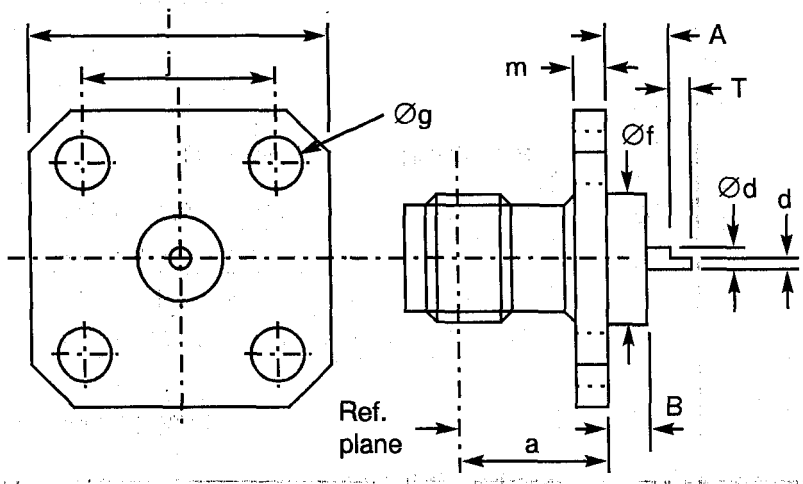

SYMBOL	MILLIMETRES		NOTES
	MIN.	MAX.	
a	7.50	7.70	4 holes
A	0.70	0.90	
B	0.20	0.40	
d	0.59	0.65	
Ød	1.25	1.30	
Øf	4.00	4.20	
Øg	2.55	2.70	
i	12.60	12.80	
j	8.59	8.69	
m	1.40	1.80	
T	1.20	1.40	

DETAILED VIEW

Semi-circular tab 

ELECTRICAL CHARACTERISTICS		VALUES	UNITS
Frequency range		0 to 18	GHz
Maximum voltage standing wave ratio (VSWR)	(1)	$1.05 + 0.003 f$ (GHz)	
Maximum reflection coefficient	(1)	$0.024 + 0.0013 f$ (GHz)	
Maximum insertion loss	(1)	$0.03 \sqrt{f}$ (GHz)	dB
RF leakage	(1)	$- [95 - f]$ (GHz)	dB
Voltage proof		1000	Vrms
Corona level		Not applicable	Vrms

NOTES

1. For information only.

MECHANICAL CHARACTERISTICS		VALUES	UNITS
Mini centre contact retention force (axial)		27	N
Mini centre contact retention torque		2.8	N.cm
Mini cable retention force		Not applicable	N
Mini cable retention torque value		Not applicable	N.cm
Maximum weight		3.0	g

OTHER CHARACTERISTICS		VALUES	UNITS
Rapid change of temperature - peak value		+ 200	°C
Operating temperature range		- 65 to + 165	°C
Maxi leakage (panel sealed connectors)		Not applicable	
Maxi leakage (hermetic sealed connector)		Not applicable	
Solderability		On centre contact only	
Soldering proof		Applicable	
Cables used		Not applicable	

FIGURE 2(b) - VARIANTS (CONTINUED)

VARIANT 40 - SQUARE FLANGE RECEPTACLE, LOW RF LEAKAGE

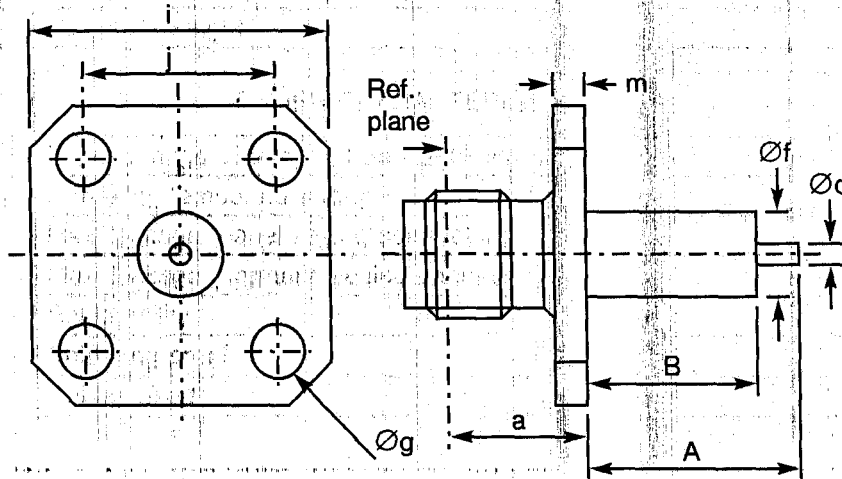

SYMBOL	MILLIMETRES		NOTES
	MIN.	MAX.	
a	7.50	7.70	
A	-	35.00	Note 1
B	-	20.00	Note 1
Ød	1.25	1.30	
Øf	4.00	4.20	
Øg	2.55	2.70	4 holes
i	12.60	12.80	
j	8.59	8.69	
m	1.40	1.80	

ELECTRICAL CHARACTERISTICS	VALUES	UNITS
Frequency range	0 to 18	GHz
Maximum voltage standing wave ratio (VSWR) (2)	$1.05 + 0.003 f$ (GHz)	
Maximum reflection coefficient (2)	$0.024 + 0.0013 f$ (GHz)	
Maximum insertion loss (2)	$0.03 \sqrt{f}$ (GHz)	dB
RF leakage (2)	- 120 at 10 GHz	dB
Voltage proof	1000	Vrms
Corona level	Not applicable	Vrms

NOTES

1. To specify dimensions, see Para. 4.5.3.
2. For information only.

MECHANICAL CHARACTERISTICS	VALUES	UNITS
Mini centre contact retention force (axial)	27	N
Mini centre contact retention torque	2.8	N.cm
Mini cable retention force	Not applicable	N
Mini cable retention torque value	Not applicable	N.cm
Maximum weight	3.0	g

OTHER CHARACTERISTICS	VALUES	UNITS
Rapid change of temperature - peak value	+ 115	°C
Operating temperature range	- 65 to + 105	°C
Maxi leakage (panel sealed connectors)	Not applicable	
Maxi leakage (hermetic sealed connector)	Not applicable	
Solderability	On centre contact only	
Soldering proof	Applicable	
Cables used	Not applicable	

FIGURE 2(b) - VARIANTS (CONTINUED)

VARIANT 41 - SQUARE FLANGE RECEPTACLE, LOW RF LEAKAGE

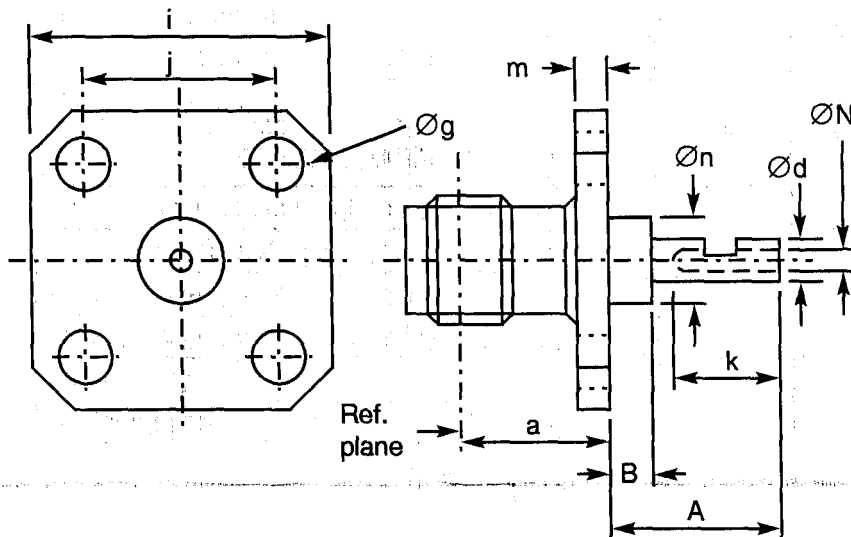

SYMBOL	MILLIMETRES		NOTES
	MIN.	MAX.	
a	7.50	7.70	4 holes
A	6.00	6.20	
B	0.90	1.00	
Ød	1.25	1.30	
Øg	2.55	2.70	
i	12.60	12.80	
j	8.59	8.69	
k	2.40	-	
m	1.40	1.80	
Øn	4.00	4.20	
ØN	0.75	-	

Solder Bucket -
Optional Shapes:



ELECTRICAL CHARACTERISTICS	VALUES	UNITS
Frequency range	0 to 18	GHz
Maximum voltage standing wave ratio (VSWR) (1)	$1.05 + 0.003 f$ (GHz)	
Maximum reflection coefficient (1)	$0.024 + 0.0013 f$ (GHz)	
Maximum insertion loss (1)	$0.03 \sqrt{f}$ (GHz)	dB
RF leakage (1)	-120 at 10 GHz	dB
Voltage proof	1000	Vrms
Corona level	Not applicable	Vrms

NOTES

1. For information only.

MECHANICAL CHARACTERISTICS	VALUES	UNITS
Mini centre contact retention force (axial)	27	N
Mini centre contact retention torque	2.8	N.cm
Mini cable retention force	Not applicable	N
Mini cable retention torque value	Not applicable	N.cm
Maximum weight	3.0	g

OTHER CHARACTERISTICS	VALUES	UNITS
Rapid change of temperature - peak value	+115	°C
Operating temperature range	-65 to +105	°C
Maxi leakage (panel sealed connectors)	Not applicable	
Maxi leakage (hermetic sealed connector)	Not applicable	
Solderability	On centre contact only	
Soldering proof	Applicable	
Cables used	Not applicable	

FIGURE 2(b) - VARIANTS (CONTINUED)

VARIANT 42 - SQUARE FLANGE RECEPTACLE, LOW RF LEAKAGE

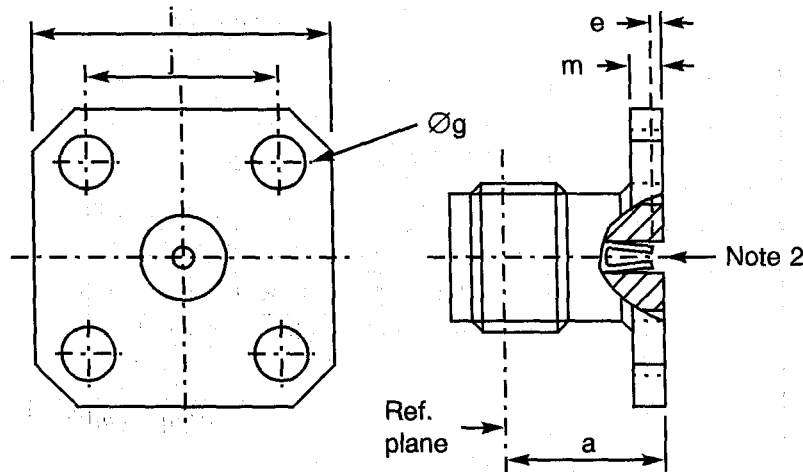

SYMBOL	MILLIMETRES		NOTES
	MIN.	MAX.	
a	7.50	7.70	4 holes
e	0.18	0.41	
Øg	2.55	2.70	
i	12.60	12.80	
j	8.59	8.69	
m	1.40	1.80	

ELECTRICAL CHARACTERISTICS	VALUES	UNITS
Frequency range	0 to 18	GHz
Maximum voltage standing wave ratio (VSWR) (1)	$1.06 + 0.007 f$ (GHz)	
Maximum reflection coefficient (1)	$0.029 + 0.0031 f$ (GHz)	
Maximum insertion loss (1)	$0.03 \sqrt{f}$ (GHz)	dB
RF leakage (1)	-120 at 10 GHz	dB
Voltage proof	1000	Vrms
Corona level	Not applicable	Vrms

NOTES

- For information only.
- Contact engagement and separation forces shall be measured on the rear contact (see Para. 4.3.8).

MECHANICAL CHARACTERISTICS	VALUES	UNITS
Mini centre contact retention force (axial)	27	N
Mini centre contact retention torque	2.8	N.cm
Mini cable retention force	Not applicable	N
Mini cable retention torque value	Not applicable	N.cm
Maximum weight	3.0	g

OTHER CHARACTERISTICS	VALUES	UNITS
Rapid change of temperature - peak value	+180	°C
Operating temperature range	-65 to +165	°C
Maxi leakage (panel sealed connectors)	Not applicable	
Maxi leakage (hermetic sealed connector)	Not applicable	
Solderability	Not applicable	
Soldering proof	Not applicable	
Cables used	Not applicable	

FIGURE 2(b) - VARIANTS (CONTINUED)

VARIANT 43 - SQUARE FLANGE RECEPTACLE, LOW RF LEAKAGE

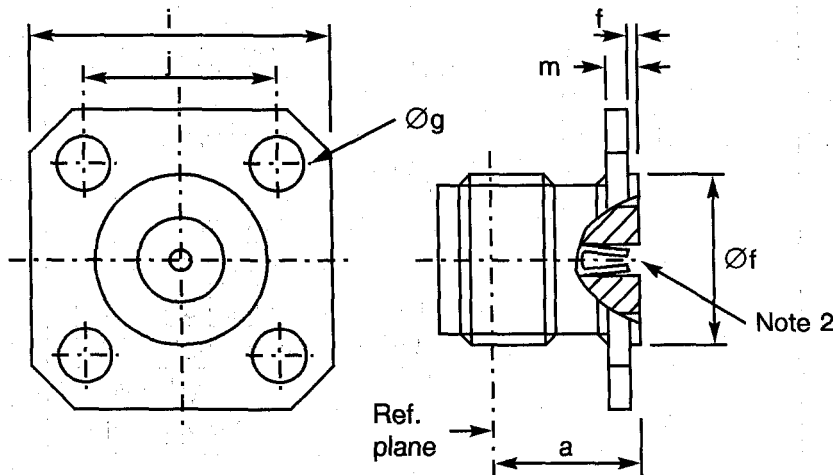

SYMBOL	MILLIMETRES		NOTES
	MIN.	MAX.	
a	7.50	7.70	4 holes
e	0.18	0.41	
f	0.30	0.50	
Øf	5.90	6.10	
Øg	2.55	2.70	
i	12.60	12.80	
j	8.59	8.69	
m	1.40	1.80	

ELECTRICAL CHARACTERISTICS	VALUES	UNITS
Frequency range	0 to 18	GHz
Maximum voltage standing wave ratio (VSWR)	$1.06 + 0.007 f$ (GHz)	
Maximum reflection coefficient	$0.029 + 0.0031 f$ (GHz)	
Maximum insertion loss (1)	$0.03 \sqrt{f}$ (GHz)	dB
RF leakage (1)	-120 at 10 GHz	dB
Voltage proof	1000	Vrms
Corona level	Not applicable	Vrms

NOTES

- For information only.
- Contact engagement and separation forces shall be measured on the rear contact (see Para. 4.3.8).

MECHANICAL CHARACTERISTICS	VALUES	UNITS
Mini centre contact retention force (axial)	27	N
Mini centre contact retention torque	Not applicable	N.cm
Mini cable retention force	Not applicable	N
Mini cable retention torque value	Not applicable	N.cm
Maximum weight	2.6	g

OTHER CHARACTERISTICS	VALUES	UNITS
Rapid change of temperature - peak value	+115	°C
Operating temperature range	-65 to +105	°C
Maxi leakage (panel sealed connectors)	Not applicable	
Maxi leakage (hermetic sealed connector)	Not applicable	
Solderability	Not applicable	
Soldering proof	Not applicable	
Cables used	Not applicable	

FIGURE 2(b) - VARIANTS (CONTINUED)

VARIANT 44 - BULKHEAD RECEPTACLE

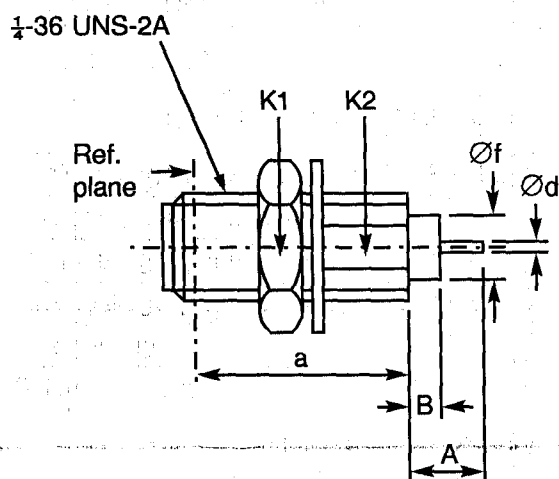

SYMBOL	MILLIMETRES		NOTES
	MIN.	MAX.	
a	10.65	10.90	
A	-	40.10	Note 2
B	-	20.00	Note 2
Ød	1.25	1.30	
Øf	4.00	4.20	
K1	-	8.00	2 flats
K2	-	5.40	2 flats

ELECTRICAL CHARACTERISTICS	VALUES	UNITS
Frequency range	0 to 18	GHz
Maximum voltage standing wave ratio (VSWR) (1)	1.05 + 0.06 f (GHz)	
Maximum reflection coefficient (1)	0.024 + 0.013 f (GHz)	
Maximum insertion loss (1)	0.03√f (GHz)	dB
RF leakage (1)	- [95 - f (GHz)]	dB
Voltage proof	1000	Vrms
Corona level	Not applicable	Vrms

NOTES

- For information only.
- To specify dimensions, refer to Para. 4.5.3.

MECHANICAL CHARACTERISTICS	VALUES	UNITS
Mini centre contact retention force (axial)	27	N
Mini centre contact retention torque	2.8	N.cm
Mini cable retention force	Not applicable	N
Mini cable retention torque value	Not applicable	N.cm
Maximum weight	2.3	g

OTHER CHARACTERISTICS	VALUES	UNITS
Rapid change of temperature - peak value	+ 115	°C
Operating temperature range	- 65 to + 105	°C
Maxi leakage (panel sealed connectors)	Not applicable	
Maxi leakage (hermetic sealed connector)	Not applicable	
Solderability	On centre contact only	
Soldering proof	Applicable	
Cables used	Not applicable	

FIGURE 2(b) - VARIANTS (CONTINUED)

VARIANT 45 - SQUARE FLANGE RECEPTACLE FOR MICRO-STRIP

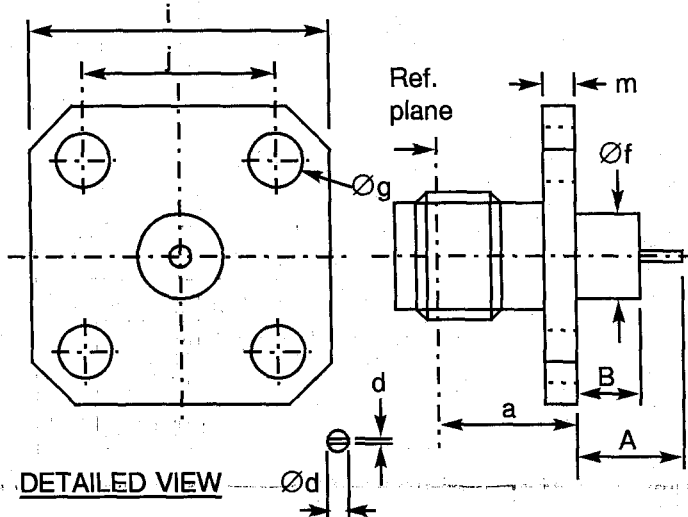

SYMBOL	MILLIMETRES		NOTES
	MIN.	MAX.	
a	7.50	7.70	
A	-	35.00	Note 1
B	-	20.00	Note 1
Ød	1.25	1.30	
d	0.10	0.15	
d1	0.55	0.65	
Øf	4.00	4.20	
Øg	2.55	2.70	4 holes
i	12.60	12.80	
j	8.59	8.69	
m	1.40	1.80	

ELECTRICAL CHARACTERISTICS	VALUES	UNITS
Frequency range	0 to 12.4	GHz
Maximum voltage standing wave ratio (VSWR) (2)	$1.05 + 0.035 f$ (GHz)	
Maximum reflection coefficient (2)	$0.024 + 0.014 f$ (GHz)	
Maximum insertion loss (2)	$0.03 \sqrt{f}$ (GHz)	dB
RF leakage (2)	$- [95 - f$ (GHz)]	dB
Voltage proof	1000	Vrms
Corona level	Not applicable	Vrms

NOTES

1. To specify dimensions refer to Para. 4.5.3.
2. For information only.

MECHANICAL CHARACTERISTICS	VALUES	UNITS
Mini centre contact retention force (axial)	27	N
Mini centre contact retention torque	2.8	N.cm
Mini cable retention force	Not applicable	N
Mini cable retention torque value	Not applicable	N.cm
Maximum weight	3.0	g

OTHER CHARACTERISTICS	VALUES	UNITS
Rapid change of temperature - peak value	+115	°C
Operating temperature range	-65 to +105	°C
Maxi leakage (panel sealed connectors)	Not applicable	
Maxi leakage (hermetic sealed connector)	Not applicable	
Solderability	On centre contact only	
Soldering proof	Applicable	
Cables used	Not applicable	

FIGURE 2(b) - VARIANTS (CONTINUED)

VARIANT 46 - 2-HOLE FLANGE RECEPTACLE FOR STRIP LINE (NON CAPTIVATED CENTRE CONTACT)

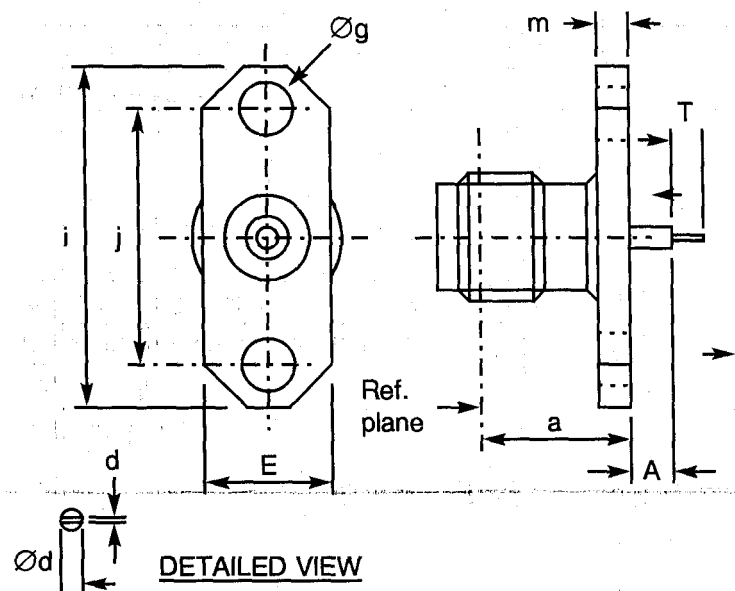

SYMBOL	MILLIMETRES		NOTES
	MIN.	MAX.	
a	7.50	7.70	2 holes
A	2.40	2.70	
d	0.10	0.15	
Ød	1.25	1.30	
E	5.50	5.80	
Øg	2.55	2.70	
i	15.90	16.10	
j	12.10	12.30	
m	1.40	1.80	
T	2.40	2.65	

ELECTRICAL CHARACTERISTICS	VALUES	UNITS
Frequency range	0 to 18	GHz
Maximum voltage standing wave ratio (VSWR)	Not applicable	
Maximum reflection coefficient	Not applicable	
Maximum insertion loss	Not applicable	dB
RF leakage	Not applicable	dB
Voltage proof	1000	Vrms
Corona level	Not applicable	Vrms

MECHANICAL CHARACTERISTICS	VALUES	UNITS
Mini centre contact retention force (axial)	Not applicable	N
Mini centre contact retention torque	Not applicable	N.cm
Mini cable retention force	Not applicable	N
Mini cable retention torque value	Not applicable	N.cm
Maximum weight	2.6	g

OTHER CHARACTERISTICS	VALUES	UNITS
Rapid change of temperature - peak value	+200	°C
Operating temperature range	-65 to +165	°C
Maxi leakage (panel sealed connectors)	Not applicable	
Maxi leakage (hermetic sealed connector)	Not applicable	
Solderability	On centre contact only	
Soldering proof	Applicable	
Cables used	Not applicable	

FIGURE 2(b) - VARIANTS (CONTINUED)

VARIANT 47 - 2-HOLE FLANGE RECEPTACLE FOR STRIP LINE (NON-CAPTIVATED CENTRE CONTACT)

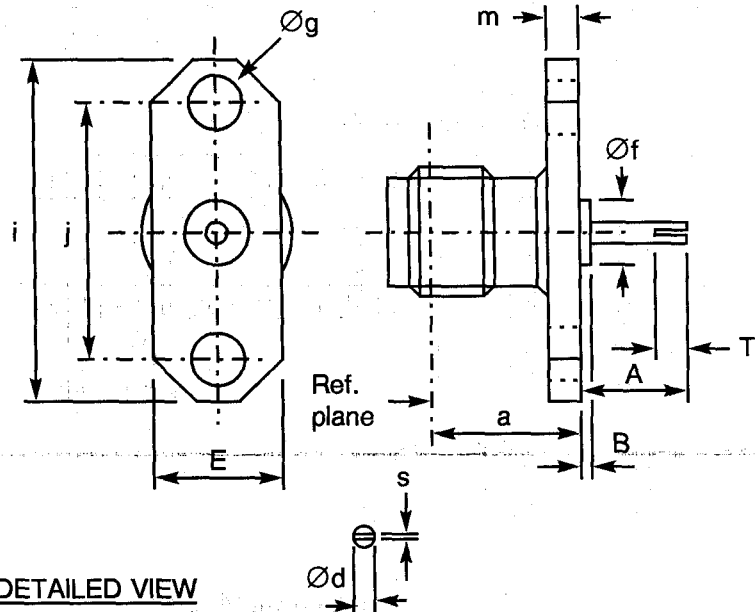

SYMBOL	MILLIMETRES		NOTES
	MIN.	MAX.	
a	7.50	7.70	2 holes
A	6.20	6.70	
$\text{Ø}d$	1.25	1.30	
B	0.40	0.65	
E	5.50	5.80	
$\text{Ø}f$	4.00	4.20	
$\text{Ø}g$	2.55	2.70	
i	15.90	16.10	
j	12.10	12.30	
m	1.40	1.80	
s	0.80	-	
T	2.40	2.65	

DETAILED VIEW

ELECTRICAL CHARACTERISTICS	VALUES	UNITS
Frequency range	0 to 18	GHz
Maximum voltage standing wave ratio (VSWR)	Not applicable	
Maximum reflection coefficient	Not applicable	
Maximum insertion loss	Not applicable	dB
RF leakage	Not applicable	dB
Voltage proof	1000	Vrms
Corona level	Not applicable	Vrms

MECHANICAL CHARACTERISTICS	VALUES	UNITS
Mini centre contact retention force (axial)	Not applicable	N
Mini centre contact retention torque	Not applicable	N.cm
Mini cable retention force	Not applicable	N
Mini cable retention torque value	Not applicable	N.cm
Maximum weight	2.6	g

OTHER CHARACTERISTICS	VALUES	UNITS
Rapid change of temperature - peak value	+ 200	°C
Operating temperature range	- 65 to + 165	°C
Maxi leakage (panel sealed connectors)	Not applicable	
Maxi leakage (hermetic sealed connector)	Not applicable	
Solderability	On centre contact only	
Soldering proof	Applicable	
Cables used	Not applicable	

FIGURE 2(b) - VARIANTS (CONTINUED)

**VARIANT 48 - SQUARE FLANGE MALE RECEPTACLE FOR MICRO-STRIP
(NON-CAPTIVATED CENTRE CONTACT)**

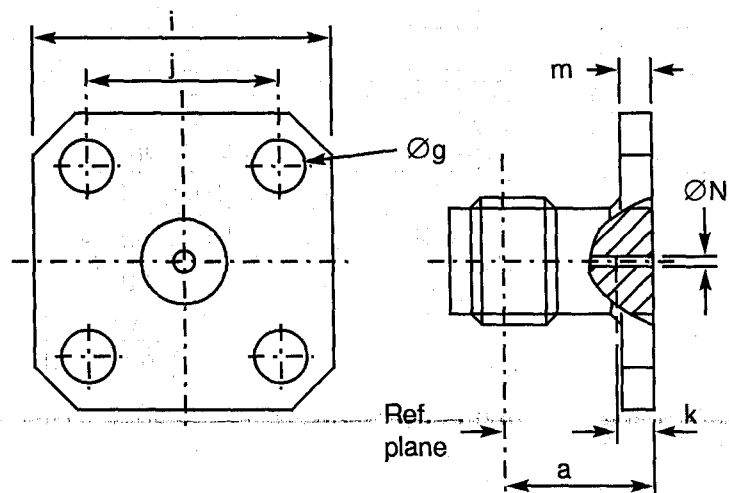

SYMBOL	MILLIMETRES		NOTES
	MIN.	MAX.	
a	7.50	7.70	4 holes
Øg	2.55	2.70	
i	12.60	12.80	
j	8.59	8.69	
k	2.30	2.70	
m	1.40	1.80	
ØN	0.70	0.90	

ELECTRICAL CHARACTERISTICS	VALUES	UNITS
Frequency range	0 to 18	GHz
Maximum voltage standing wave ratio (VSWR)	Not applicable	
Maximum reflection coefficient	Not applicable	
Maximum insertion loss	Not applicable	dB
RF leakage	Not applicable	dB
Voltage proof	1000	Vrms
Corona level	Not applicable	Vrms

MECHANICAL CHARACTERISTICS	VALUES	UNITS
Mini centre contact retention force (axial)	Not applicable	N
Mini centre contact retention torque	Not applicable	N.cm
Mini cable retention force	Not applicable	N
Mini cable retention torque value	Not applicable	N.cm
Maximum weight	2.6	g

OTHER CHARACTERISTICS	VALUES	UNITS
Rapid change of temperature - peak value	+200	°C
Operating temperature range	-65 to +165	°C
Maxi leakage (panel sealed connectors)	Not applicable	
Maxi leakage (hermetic sealed connector)	Not applicable	
Solderability	On centre contact only	
Soldering proof	Not applicable	
Cables used	Not applicable	

FIGURE 2(b) - VARIANTS (CONTINUED)

VARIANT 49 - 2-HOLE FLANGE RECEPTACLE

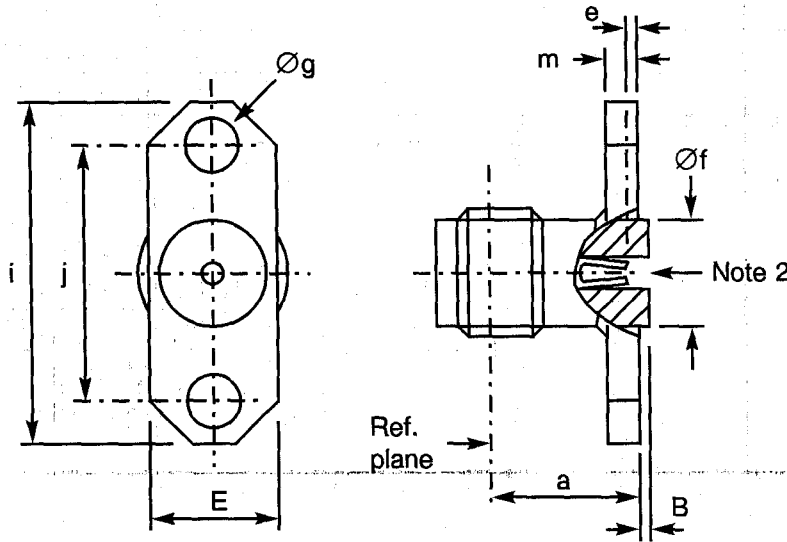

SYMBOL	MILLIMETRES		NOTES
	MIN.	MAX.	
a	7.50	7.60	2 holes
B	0.15	0.25	
e	0.18	0.41	
E	5.50	5.80	
Øf	4.00	4.20	
Øg	2.55	2.70	
i	15.90	16.10	
j	12.10	12.30	
m	1.40	1.80	

ELECTRICAL CHARACTERISTICS		VALUES	UNITS
Frequency range		0 to 18	GHz
Maximum voltage standing wave ratio (VSWR)	(1)	$1.06 + 0.006 f$ (GHz)	
Maximum reflection coefficient	(1)	$0.029 + 0.0026 f$ (GHz)	
Maximum insertion loss	(1)	$0.03 \sqrt{f}$ (GHz)	dB
RF leakage	(1)	$- [95 - f]$ (GHz)	dB
Voltage proof		1000	Vrms
Corona level		Not applicable	Vrms

NOTES

- For information only.
- Contact engagement and separation forces shall be measured on the rear contact (see Para. 4.3.8).

MECHANICAL CHARACTERISTICS		VALUES	UNITS
Mini centre contact retention force (axial)		27	N
Mini centre contact retention torque		2.8	N.cm
Mini cable retention force		Not applicable	N
Mini cable retention torque value		Not applicable	N.cm
Maximum weight		2.0	g

OTHER CHARACTERISTICS		VALUES	UNITS
Rapid change of temperature - peak value		+115	°C
Operating temperature range		-65 to +105	°C
Maxi leakage (panel sealed connectors)		Not applicable	
Maxi leakage (hermetic sealed connector)		Not applicable	
Solderability		Not applicable	
Soldering proof		Not applicable	
Cables used		Not applicable	

FIGURE 2(b) - VARIANTS (CONTINUED)

VARIANT 50 - SQUARE FLANGE RECEPTACLE

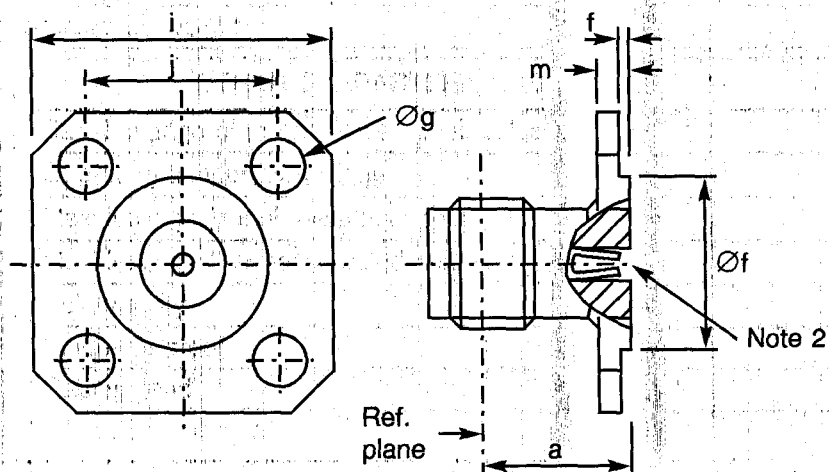

SYMBOL	MILLIMETRES		NOTES
	MIN.	MAX.	
a	7.50	7.70	4 holes
e	0.18	0.41	
f	0.30	0.50	
Øf	5.90	6.10	
Øg	2.55	2.70	
i	12.60	12.80	
j	8.59	8.69	
m	1.40	1.80	

ELECTRICAL CHARACTERISTICS		VALUES	UNITS
Frequency range		0 to 18	GHz
Maximum voltage standing wave ratio (VSWR)	(1)	$1.06 + 0.007 f$ (GHz)	
Maximum reflection coefficient	(1)	$0.029 + 0.0031 f$ (GHz)	
Maximum insertion loss	(1)	$0.03 \sqrt{f}$ (GHz)	dB
RF leakage	(1)	$- [95 - f]$ (GHz)	dB
Voltage proof		1000	V _{rms}
Corona level		Not applicable	V _{rms}

NOTES

- For information only.
- Contact engagement and separation forces shall be measured on the rear contact (see Para. 4.3.8).

MECHANICAL CHARACTERISTICS		VALUES	UNITS
Mini centre contact retention force (axial)		27	N
Mini centre contact retention torque		Not applicable	N.cm
Mini cable retention force		Not applicable	N
Mini cable retention torque value		Not applicable	N.cm
Maximum weight		2.6	g

OTHER CHARACTERISTICS		VALUES	UNITS
Rapid change of temperature - peak value		+ 115	°C
Operating temperature range		- 65 to + 105	°C
Maxi leakage (panel sealed connectors)		Not applicable	
Maxi leakage (hermetic sealed connector)		Not applicable	
Solderability		Not applicable	
Soldering proof		Not applicable	
Cables used		Not applicable	

FIGURE 2(b) - VARIANTS (CONTINUED)

VARIANT 51 - SQUARE FLANGE RECEPTACLE

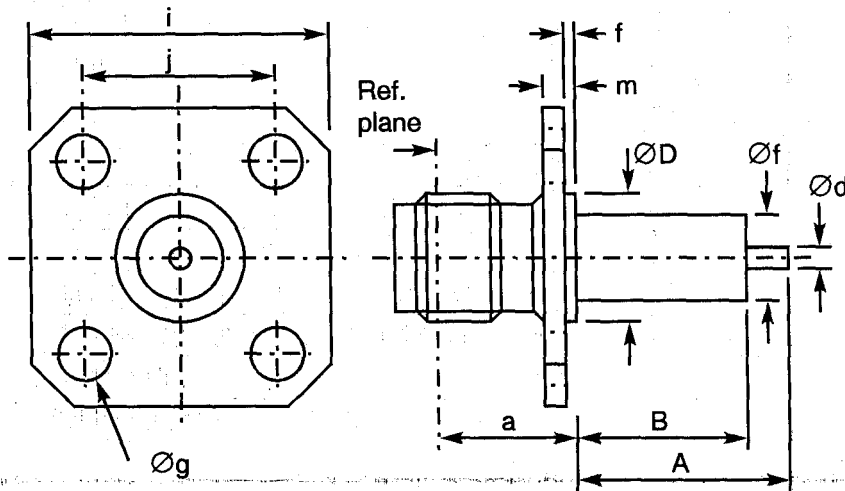

SYMBOL	MILLIMETRES		NOTES
	MIN.	MAX.	
a	7.50	7.70	
A	-	40.10	Note 2
B	-	30.00	Note 2
Ød	1.25	1.30	
ØD	5.90	6.10	
f	0.30	0.50	
Øf	4.00	4.20	
Øg	2.55	2.70	4 holes
i	12.60	12.80	
j	8.59	8.69	
m	1.40	1.80	

ELECTRICAL CHARACTERISTICS	VALUES	UNITS
Frequency range	0 to 18	GHz
Maximum voltage standing wave ratio (VSWR) (1)	$1.05 + 0.003 f$ (GHz)	
Maximum reflection coefficient (1)	$0.024 + 0.0013 f$ (GHz)	
Maximum insertion loss (1)	$0.03 \sqrt{f}$ (GHz)	dB
RF leakage (1)	$-[95 - f]$ (GHz)	dB
Voltage proof	1000	Vrms
Corona level	Not applicable	Vrms

NOTES

1. For information only.
2. To specify dimensions, see Para. 4.5.3.

MECHANICAL CHARACTERISTICS	VALUES	UNITS
Mini centre contact retention force (axial)	27	N
Mini centre contact retention torque	2.8	N.cm
Mini cable retention force	Not applicable	N
Mini cable retention torque value	Not applicable	N.cm
Maximum weight	3.0	g

OTHER CHARACTERISTICS	VALUES	UNITS
Rapid change of temperature - peak value	+115	°C
Operating temperature range	-65 to +105	°C
Maxi leakage (panel sealed connectors)	Not applicable	
Maxi leakage (hermetic sealed connector)	Not applicable	
Solderability	Not applicable	
Soldering proof	Not applicable	
Cables used	Not applicable	

FIGURE 2(b) - VARIANTS (CONTINUED)

VARIANT 53 - STRAIGHT JACK, SOLDER TYPE, FOR SHF 5 CABLE

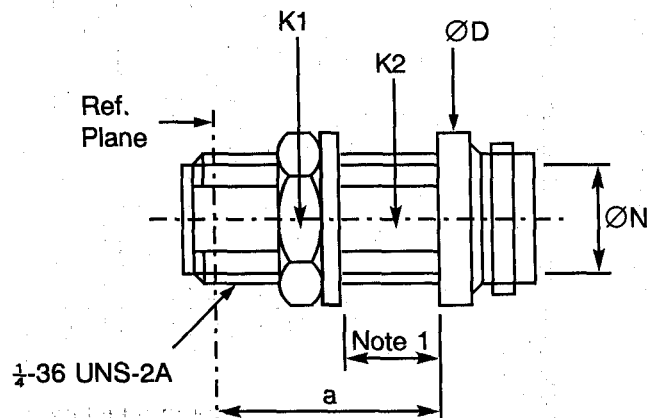

SYMBOL	MILLIMETRES		NOTES
	MIN.	MAX.	
a	14.20	14.45	
ØD	10.90	11.10	
K1	-	8.00	Hexagon 1 flat
K2	-	5.90	
ØN	5.90	-	

NOTES

1. Maximum panel thickness: 5.40mm.

ELECTRICAL CHARACTERISTICS	VALUES	UNITS
Frequency range	0 to 18	GHz
Maximum voltage standing wave ratio (VSWR)	1.15	
Maximum reflection coefficient	0.069	
Maximum insertion loss	$0.06\sqrt{f}$ (GHz)	dB
RF leakage	- [95 - f (GHz)]	dB
Voltage proof	1000	Vrms
Corona level	250	Vrms

MECHANICAL CHARACTERISTICS	VALUES	UNITS
Mini centre contact retention force (axial)	Not applicable	N
Mini centre contact retention torque	Not applicable	N.cm
Mini cable retention force	10	N
Mini cable retention torque value	Not applicable	N.cm
Maximum weight	7.0	g

OTHER CHARACTERISTICS	VALUES	UNITS
Rapid change of temperature - peak value	+ 200	°C
Operating temperature range	- 65 to + 165	°C
Maxi leakage (panel sealed connectors)	Not applicable	
Maxi leakage (hermetic sealed connector)	Not applicable	
Solderability	Applicable	
Soldering proof	Applicable	
Cables used	F 1703.145	

FIGURE 2(b) - VARIANTS (CONTINUED)

VARIANT 54 - 2-HOLE FLANGE RECEPTACLE, LOW RF LEAKAGE

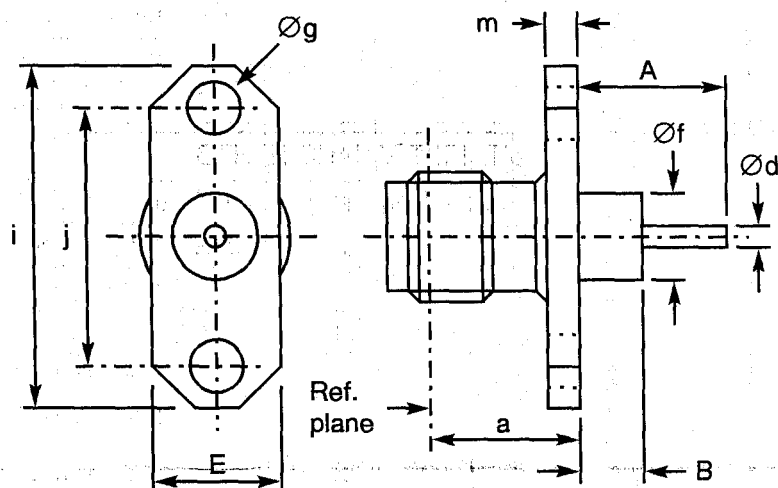

SYMBOL	MILLIMETRES		NOTES
	MIN.	MAX.	
a	7.50	7.70	
A	-	40.10	Note 2
B	-	20.00	Note 2
Ød	1.25	1.30	
E	5.50	5.80	
Øf	4.00	4.20	
Øg	2.55	2.70	2 holes
i	15.90	16.10	
j	12.10	12.30	
m	1.40	1.80	

ELECTRICAL CHARACTERISTICS		VALUES	UNITS
Frequency range		0 to 18	GHz
Maximum voltage standing wave ratio (VSWR)	(1)	1.05 + 0.003 f (GHz)	
Maximum reflection coefficient	(1)	0.024 + 0.0013 f (GHz)	
Maximum insertion loss	(1)	0.03 √f (GHz)	dB
RF leakage	(1)	-120 at 10 GHz	dB
Voltage proof		1000	Vrms
Corona level		Not applicable	Vrms

NOTES

1. For information only.
2. To specify dimensions, see Para. 4.5.3.

MECHANICAL CHARACTERISTICS		VALUES	UNITS
Mini centre contact retention force (axial)		27	N
Mini centre contact retention torque		2.8	N.cm
Mini cable retention force		Not applicable	N
Mini cable retention torque value		Not applicable	N.cm
Maximum weight		3.0	g

OTHER CHARACTERISTICS		VALUES	UNITS
Rapid change of temperature - peak value		+115	°C
Operating temperature range		-65 to +105	°C
Maxi leakage (panel sealed connectors)		Not applicable	
Maxi leakage (hermetic sealed connector)		Not applicable	
Solderability		On centre contact only	
Soldering proof		Applicable	
Cables used		Not applicable	

FIGURE 2(b) - VARIANTS (CONTINUED)

VARIANT 55 - ELBOW RECEPTACLE, ROUND FLANGE, TRIPLATE LAUNCHER

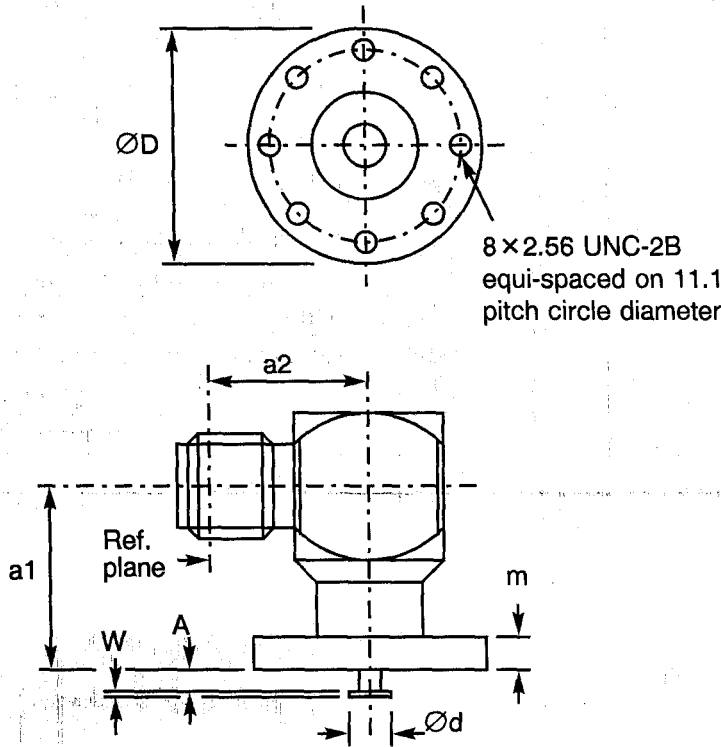

SYMBOL	MILLIMETRES		NOTES
	MIN.	MAX.	
a1	9.15	9.40	
a2	9.20	9.40	
A	0.94	1.70	
Ød	1.70	1.90	
ØD	14.00	14.40	
m	1.95	2.30	
W	0.15	0.35	

ELECTRICAL CHARACTERISTICS	VALUES	UNITS
Frequency range	0 to 4.0	GHz
Maximum voltage standing wave ratio (VSWR)	1.20	
Maximum reflection coefficient	0.0909	
Maximum insertion loss	Not applicable	dB
RF leakage	Not applicable	dB
Voltage proof	750	Vrms
Corona level	Not applicable	Vrms
MECHANICAL CHARACTERISTICS	VALUES	UNITS
Mini centre contact retention force (axial)	Not applicable	N
Mini centre contact retention torque	Not applicable	N.cm
Mini cable retention force	Not applicable	N
Mini cable retention torque value	Not applicable	N.cm
Maximum weight	5.8	g
OTHER CHARACTERISTICS	VALUES	UNITS
Rapid change of temperature - peak value	+200	°C
Operating temperature range	-65 to +165	°C
Maxi leakage (panel sealed connectors)	Not applicable	
Maxi leakage (hermetic sealed connector)	Not applicable	
Solderability	Applicable	
Soldering proof	Applicable	
Cables used	Not applicable	

FIGURE 2(b) - VARIANTS (CONTINUED)

VARIANT 56 - SQUARE FLANGE RECEPTACLE, LOW RF LEAKAGE

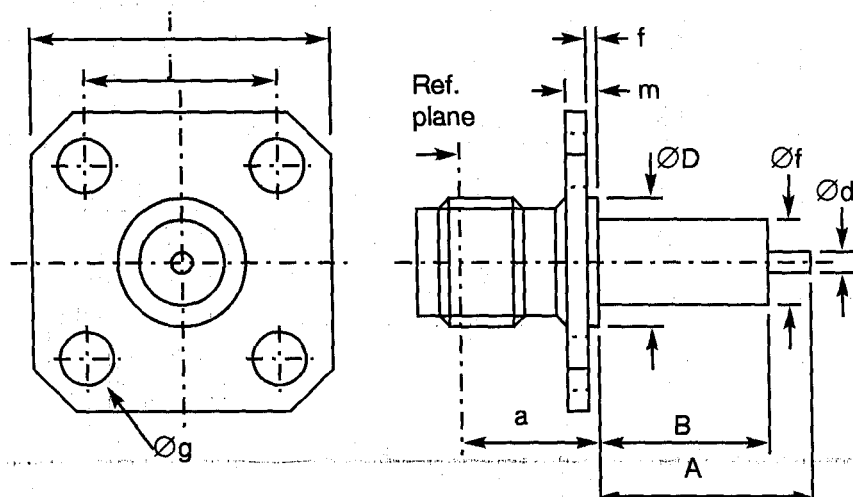

SYMBOL	MILLIMETRES		NOTES
	MIN.	MAX.	
a	7.50	7.70	
A	-	40.10	Note 2
B	-	20.00	Note 2
Ød	1.25	1.50	
ØD	5.90	6.10	
f	0.30	0.40	
Øf	4.00	4.20	
Øg	2.55	2.70	4 holes
i	12.60	12.80	
j	8.59	8.69	
m	1.40	1.90	

ELECTRICAL CHARACTERISTICS	VALUES	UNITS
Frequency range	0 to 18	GHz
Maximum voltage standing wave ratio (VSWR) (1)	1.05 + 0.003 f (GHz)	
Maximum reflection coefficient (1)	0.024 + 0.0013 f (GHz)	
Maximum insertion loss (1)	0.03√f (GHz)	dB
RF leakage	-120 at 10 GHz	dB
Voltage proof	1000	Vrms
Corona level	Not applicable	Vrms

NOTES

- For information only.
- To specify dimensions, see Para. 4.5.3.

MECHANICAL CHARACTERISTICS	VALUES	UNITS
Mini centre contact retention force (axial)	27	N
Mini centre contact retention torque	2.8	N.cm
Mini cable retention force	Not applicable	N
Mini cable retention torque value	Not applicable	N.cm
Maximum weight	3.0	g

OTHER CHARACTERISTICS	VALUES	UNITS
Rapid change of temperature - peak value	+115	°C
Operating temperature range	-65 to +105	°C
Maxi leakage (panel sealed connectors)	Not applicable	
Maxi leakage (hermetic sealed connector)	Not applicable	
Solderability	On centre contact only	
Soldering proof	Applicable	
Cables used	Not applicable	

FIGURE 2(b) - VARIANTS (CONTINUED)

VARIANT 57 - ROUND FLANGE RECEPTACLE, TRIPLATE LAUNCHER

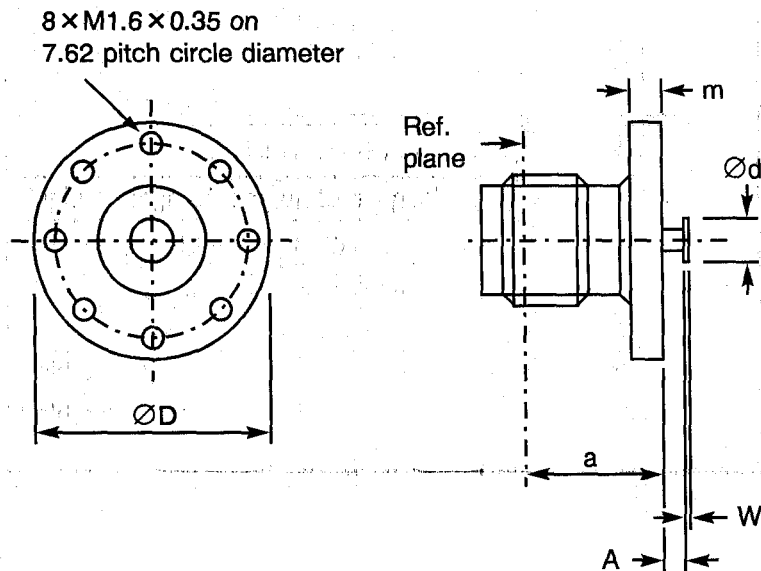

SYMBOL	MILLIMETRES		NOTES
	MIN.	MAX.	
a	7.50	7.70	After assembly
A	3.00	3.40	
Ød	1.70	1.90	
ØD	10.10	10.50	
m	2.10	2.25	
W	0.20	0.30	

ELECTRICAL CHARACTERISTICS	VALUES	UNITS
Frequency range	0 to 2.0	GHz
Maximum voltage standing wave ratio (VSWR)	1.20	
Maximum reflection coefficient	0.0909	
Maximum insertion loss	Not applicable	dB
RF leakage	Not applicable	dB
Voltage proof	1000	Vrms
Corona level	Not applicable	Vrms

MECHANICAL CHARACTERISTICS	VALUES	UNITS
Mini centre contact retention force (axial)	Not applicable	N
Mini centre contact retention torque	Not applicable	N.cm
Mini cable retention force	Not applicable	N
Mini cable retention torque value	Not applicable	N.cm
Maximum weight	2.6	g

OTHER CHARACTERISTICS	VALUES	UNITS
Rapid change of temperature - peak value	+ 200	°C
Operating temperature range	- 65 to + 165	°C
Maxi leakage (panel sealed connectors)	Not applicable	
Maxi leakage (hermetic sealed connector)	Not applicable	
Solderability	Applicable	
Soldering proof	Applicable	
Cables used	Not applicable	

FIGURE 2(b) - VARIANTS (CONTINUED)

VARIANT 58 - SQUARE FLANGE RECEPTACLE, LOW RF LEAKAGE

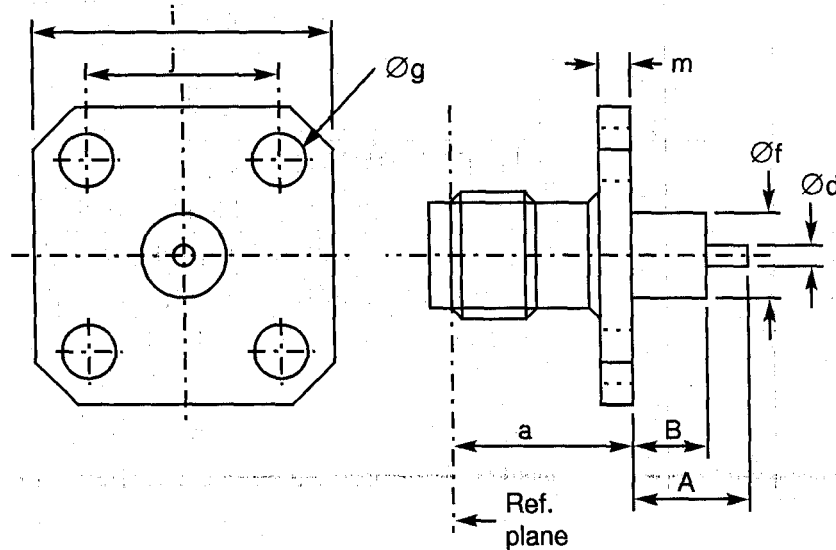

SYMBOL	MILLIMETRES		NOTES
	MIN.	MAX.	
a	7.45	7.70	
A	-	40.10	Note 2
B	-	20.00	Note 2
Ød	0.40	0.60	
Øf	4.00	4.20	
Øg	2.55	2.70	4 holes
i	12.60	12.80	
j	8.59	8.69	
m	1.40	1.80	

ELECTRICAL CHARACTERISTICS		VALUES	UNITS
Frequency range		0 to 18	GHz
Maximum voltage standing wave ratio (VSWR)	(1)	$1.05 + 0.003 f$ (GHz)	
Maximum reflection coefficient	(1)	$0.024 + 0.0013 f$ (GHz)	
Maximum insertion loss	(1)	$0.03 \sqrt{f}$ (GHz)	dB
RF leakage	(1)	-120 at 10 GHz	dB
Voltage proof		1000	Vrms
Corona level		Not applicable	Vrms

NOTES

1. For information only.
2. To specify dimensions refer to Para. 4.5.3.

MECHANICAL CHARACTERISTICS		VALUES	UNITS
Mini centre contact retention force (axial)		27	N
Mini centre contact retention torque		2.8	N.cm
Mini cable retention force		Not applicable	N
Mini cable retention torque value		Not applicable	N.cm
Maximum weight		3.0	g

OTHER CHARACTERISTICS		VALUES	UNITS
Rapid change of temperature - peak value		+115	°C
Operating temperature range		-65 to +105	°C
Maxi leakage (panel sealed connectors)		Not applicable	
Maxi leakage (hermetic sealed connector)		Not applicable	
Solderability		Applicable (contact only)	
Soldering proof		Applicable	
Cables used		Not applicable	

FIGURE 2(b) - VARIANTS (CONTINUED)

**VARIANT 59 - 2-HOLE FLANGE MALE RECEPTACLE WITH
EMI GASKET AND GLASS SEAL Ø CONTACT 0.46**

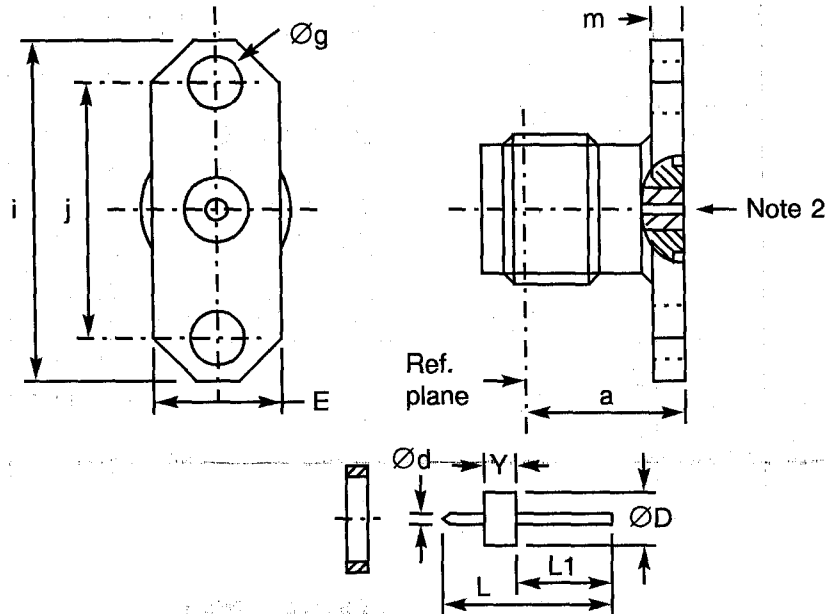

SYMBOL	MILLIMETRES		NOTES
	MIN.	MAX.	
a	7.45	7.70	2 holes
Ød	-	0.47	
ØD	-	2.86	
E	5.41	5.91	
Øg	2.55	2.70	
i	15.90	16.10	
j	12.10	12.30	
L	7.80	8.20	
L1	4.45	4.70	
m	1.40	1.80	
Y	1.55	1.65	

ELECTRICAL CHARACTERISTICS	VALUES	UNITS
Frequency range	0 to 18	GHz
Maximum voltage standing wave ratio (VSWR) (1)	1.06 + 0.01 f (GHz)	
Maximum reflection coefficient (1)	0.029 + 0.0043 f (GHz)	
Maximum insertion loss (1)	0.3	dB
RF leakage (1)	-70	dB
Voltage proof	1000	V _{rms}
Corona level	Not applicable	V _{rms}

NOTES

- For information only.
- Accept contact Ø0.46mm.

MECHANICAL CHARACTERISTICS	VALUES	UNITS
Mini centre contact retention force (axial)	27	N
Mini centre contact retention torque	Not applicable	N.cm
Mini cable retention force	Not applicable	N
Mini cable retention torque value	Not applicable	N.cm
Maximum weight	2.1	g

OTHER CHARACTERISTICS	VALUES	UNITS
Rapid change of temperature - peak value	+115	°C
Operating temperature range	-65 to +105	°C
Maxi leakage (panel sealed connectors)	Not applicable	
Maxi leakage (hermetic sealed connector)	10 ⁻⁸ (seal only)	atm.cm ³ /s
Solderability	Applicable (contact only)	
Soldering proof	Applicable	
Cables used	Not applicable	

FIGURE 2(b) - VARIANTS (CONTINUED)

VARIANT 60 - BULKHEAD RECEPTACLE WITH GLASS SEAL Ø CONTACT 0.30

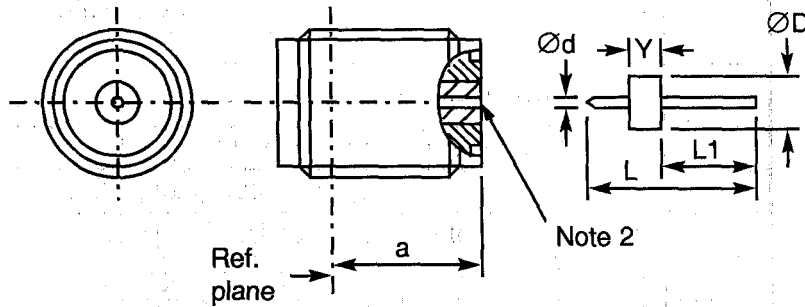

SYMBOL	MILLIMETRES		NOTES
	MIN.	MAX.	
a	7.05	8.05	
Ød	-	0.31	
ØD	-	2.53	
L	7.80	8.20	
L1	4.45	4.70	
Y	1.55	1.65	

ELECTRICAL CHARACTERISTICS	VALUES	UNITS
Frequency range	0 to 18	GHz
Maximum voltage standing wave ratio (VSWR) (1)	1.06 + 0.01 f (GHz)	
Maximum reflection coefficient (1)	0.029 + 0.0043 f (GHz)	
Maximum insertion loss (1)	0.3	dB
RF leakage (1)	-70	dB
Voltage proof	1000	Vrms
Corona level	Not applicable	Vrms

NOTES

1. For information only.
2. Accept contact Ø0.30mm.

MECHANICAL CHARACTERISTICS	VALUES	UNITS
Mini centre contact retention force (axial)	27	N
Mini centre contact retention torque	Not applicable	N.cm
Mini cable retention force	Not applicable	N
Mini cable retention torque value	Not applicable	N.cm
Maximum weight	1.7	g

OTHER CHARACTERISTICS	VALUES	UNITS
Rapid change of temperature - peak value	+115	°C
Operating temperature range	-65 to +105	°C
Maxi leakage (panel sealed connectors)	Not applicable	
Maxi leakage (hermetic sealed connector)	10 ⁻⁸ (seal only)	atm.cm ³ /s
Solderability	Applicable (contact only)	
Soldering proof	Applicable	
Cables used	Not applicable	

FIGURE 2(b) - VARIANTS (CONTINUED)

VARIANT 61 - BULKHEAD RECEPTACLE WITH GLASS SEAL \varnothing CONTACT 0.46

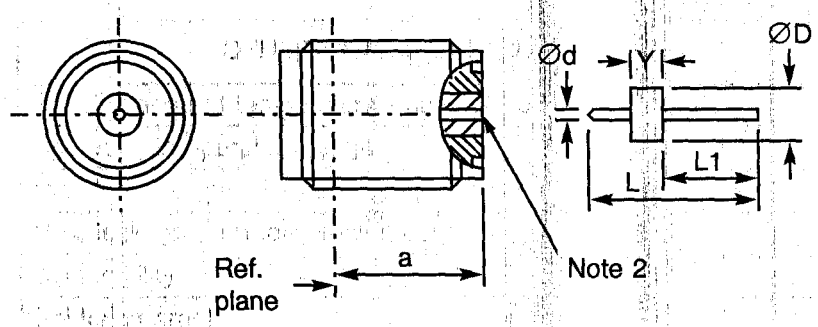

SYMBOL	MILLIMETRES		NOTES
	MIN.	MAX.	
a	7.05	8.05	
Ød	-	0.47	
ØD	-	2.86	
L	7.80	8.20	
L1	4.45	4.70	
Y	1.55	1.65	

ELECTRICAL CHARACTERISTICS	VALUES	UNITS
Frequency range	0 to 18	GHz
Maximum voltage standing wave ratio (VSWR) (1)	$1.06 + 0.01 f$ (GHz)	
Maximum reflection coefficient (1)	$0.029 + 0.0043 f$ (GHz)	
Maximum insertion loss (1)	0.3	dB
RF leakage (1)	-70	dB
Voltage proof	1000	Vrms
Corona level	Not applicable	Vrms

NOTES

1. For information only.
2. Accept contact $\varnothing 0.46\text{mm}$.

MECHANICAL CHARACTERISTICS	VALUES	UNITS
Mini centre contact retention force (axial)	27	N
Mini centre contact retention torque	Not applicable	N.cm
Mini cable retention force	Not applicable	N
Mini cable retention torque value	Not applicable	N.cm
Maximum weight	1.7	g

OTHER CHARACTERISTICS	VALUES	UNITS
Rapid change of temperature - peak value	+115	$^{\circ}\text{C}$
Operating temperature range	-65 to +105	$^{\circ}\text{C}$
Maxi leakage (panel sealed connectors)	Not applicable	
Maxi leakage (hermetic sealed connector)	10^{-8} (seal only)	$\text{atm.cm}^3/\text{s}$
Solderability	Applicable (contact only)	
Soldering proof	Applicable	
Cables used	Not applicable	

FIGURE 2(b) - VARIANTS (CONTINUED)

VARIANT 62 - HERMETIC BULKHEAD RECEPTACLE

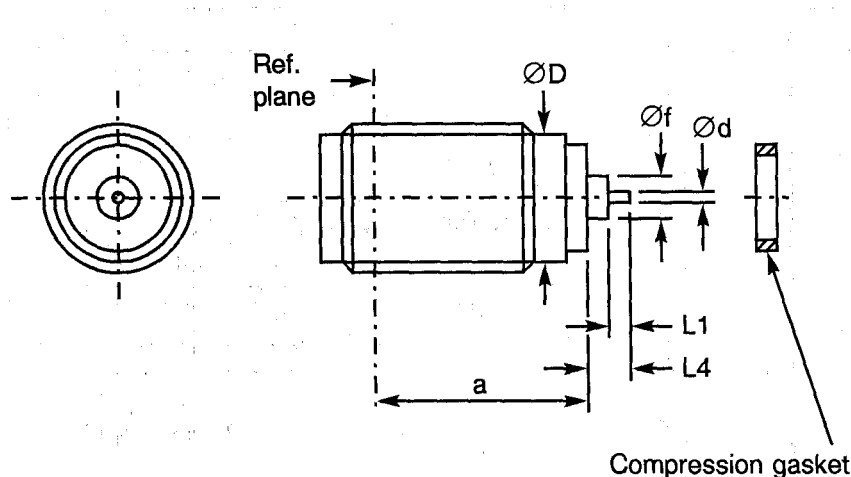

SYMBOL	MILLIMETRES		NOTES
	MIN.	MAX.	
a	9.05	10.05	
Ød	-	0.51	
ØD	5.30	5.40	
Øf	-	1.67	
L1	0.62	1.25	
L4	1.72	2.25	

ELECTRICAL CHARACTERISTICS	VALUES	UNITS
Frequency range	0 to 18	GHz
Maximum voltage standing wave ratio (VSWR) (1)	1.06 + 0.01 f (GHz)	
Maximum reflection coefficient (1)	0.029 + 0.0043 f (GHz)	
Maximum insertion loss (1)	0.3	dB
RF leakage (1)	-70	dB
Voltage proof	1000	Vrms
Corona level	Not applicable	Vrms

NOTES

1. For information only.

MECHANICAL CHARACTERISTICS	VALUES	UNITS
Mini centre contact retention force (axial)	27	N
Mini centre contact retention torque	Not applicable	N.cm
Mini cable retention force	Not applicable	N
Mini cable retention torque value	Not applicable	N.cm
Maximum weight	2.0	g

OTHER CHARACTERISTICS	VALUES	UNITS
Rapid change of temperature - peak value	+115	°C
Operating temperature range	-65 to +105	°C
Maxi leakage (panel sealed connectors)	Not applicable	
Maxi leakage (hermetic sealed connector)	10 ⁻⁸	atm.cm ³ /s
Solderability	Applicable (contact only)	
Soldering proof	Applicable	
Cables used	Not applicable	

FIGURE 2(b) - VARIANTS (CONTINUED)

VARIANT 63 - HERMETIC BULKHEAD RECEPTACLE

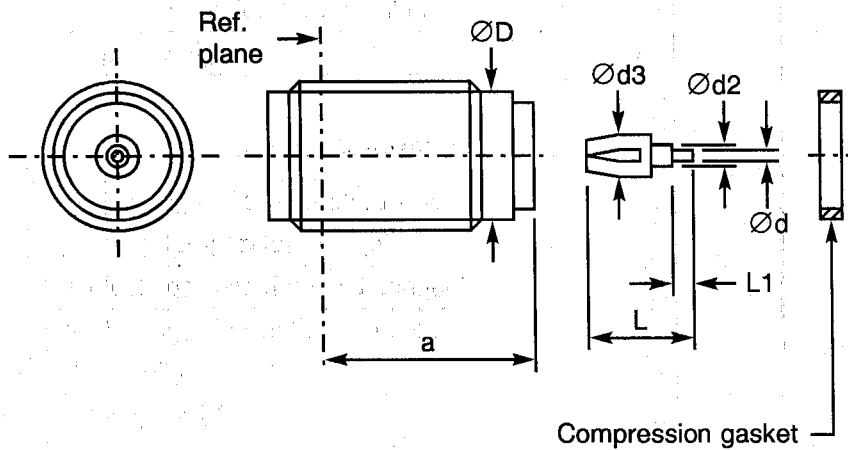

SYMBOL	MILLIMETRES		NOTES
	MIN.	MAX.	
a	9.05	10.05	
Ød	0.45	0.55	
Ød2	0.65	0.95	
Ød3	1.30	1.50	
ØD	5.30	5.40	
L	-	4.25	
L1	0.70	-	

ELECTRICAL CHARACTERISTICS	VALUES	UNITS
Frequency range	0 to 18	GHz
Maximum voltage standing wave ratio (VSWR) (1)	1.06 + 0.01 f (GHz)	
Maximum reflection coefficient (1)	0.029 + 0.0043 f (GHz)	
Maximum insertion loss (1)	0.3	dB
RF leakage (1)	-70	dB
Voltage proof	1000	Vrms
Corona level	Not applicable	Vrms

NOTES

1. For information only.

MECHANICAL CHARACTERISTICS	VALUES	UNITS
Mini centre contact retention force (axial)	27	N
Mini centre contact retention torque	Not applicable	N.cm
Mini cable retention force	Not applicable	N
Mini cable retention torque value	Not applicable	N.cm
Maximum weight	2.0	g

OTHER CHARACTERISTICS	VALUES	UNITS
Rapid change of temperature - peak value	+115	°C
Operating temperature range	-65 to +105	°C
Maxi leakage (panel sealed connectors)	Not applicable	
Maxi leakage (hermetic sealed connector)	10 ⁻⁸	atm.cm ³ /s
Solderability	Applicable (contact only)	
Soldering proof	Applicable	
Cables used	Not applicable	

FIGURE 2(b) - VARIANTS (CONTINUED)

VARIANT 64 - HERMETIC BULKHEAD RECEPTACLE

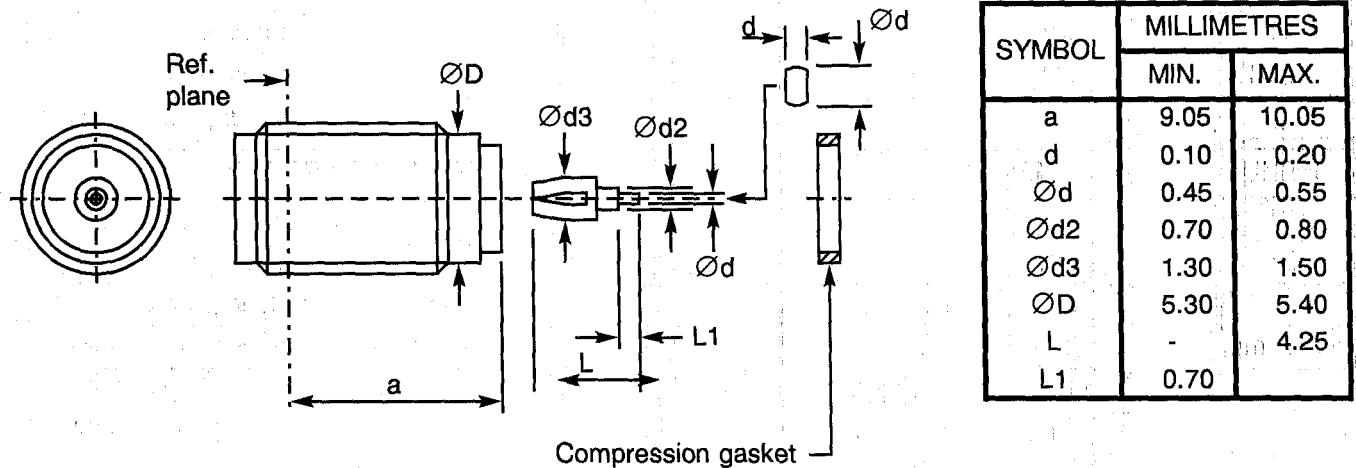

ELECTRICAL CHARACTERISTICS	VALUES	UNITS
Frequency range	0 to 18	GHz
Maximum voltage standing wave ratio (VSWR)	$1.06 + 0.01 f$ (GHz)	
Maximum reflection coefficient (1)	$0.029 + 0.0043 f$ (GHz)	
Maximum insertion loss	0.3	dB
RF leakage	-70	dB
Voltage proof	1000	Vrms
Corona level	Not applicable	Vrms

NOTES

1. For information only.

MECHANICAL CHARACTERISTICS	VALUES	UNITS
Mini centre contact retention force (axial)	27	N
Mini centre contact retention torque	Not applicable	N.cm
Mini cable retention force	Not applicable	N
Mini cable retention torque value	Not applicable	N.cm
Maximum weight	2.0	g

OTHER CHARACTERISTICS	VALUES	UNITS
Rapid change of temperature - peak value	+115	°C
Operating temperature range	-65 to +105	°C
Maxi leakage (panel sealed connectors)	Not applicable	
Maxi leakage (hermetic sealed connector)	10^{-8}	atm.cm ³ /s
Solderability	Applicable (contact only)	
Soldering proof	Applicable	
Cables used	Not applicable	

FIGURE 2(b) - VARIANTS (CONTINUED)

**VARIANT 65 - 2-HOLE FLANGE MALE RECEPTACLE WITH
EMI GASKET AND GLASS SEAL Ø CONTACT 0.30**

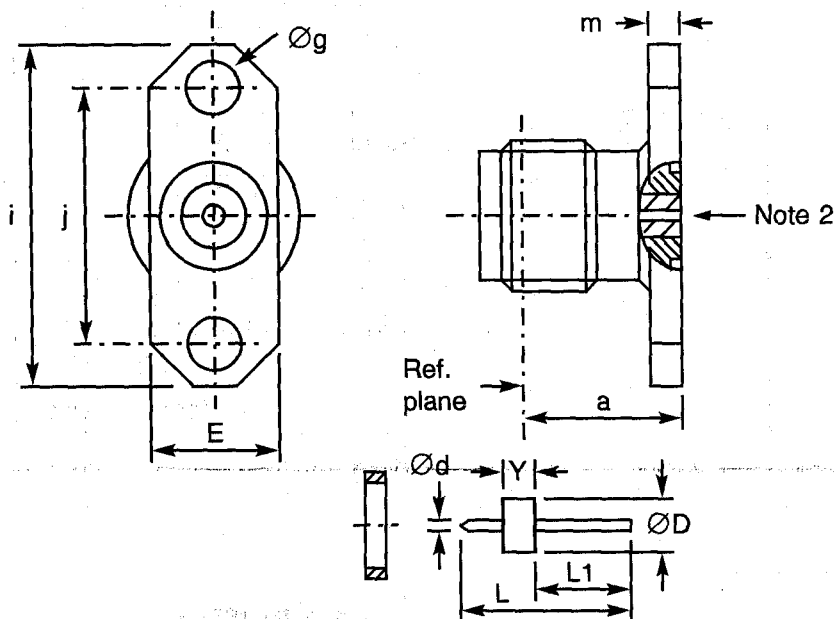

SYMBOL	MILLIMETRES		NOTES
	MIN.	MAX.	
a	7.45	7.65	2 holes
Ød	-	0.31	
ØD	-	2.53	
E	5.41	5.91	
Øg	2.55	2.70	
i	15.90	16.10	
j	12.10	12.30	
L	7.80	8.20	
L1	4.45	4.70	
m	1.40	1.80	
Y	1.55	1.65	

ELECTRICAL CHARACTERISTICS	VALUES	UNITS
Frequency range	0 to 18	GHz
Maximum voltage standing wave ratio (VSWR)	$1.06 + 0.01 f$ (GHz)	
Maximum reflection coefficient (1)	$0.029 + 0.0043 f$ (GHz)	
Maximum insertion loss	0.3	dB
RF leakage	-70	dB
Voltage proof	1000	Vrms
Corona level	Not applicable	Vrms

NOTES

- For information only.
- Accept contact Ø0.30mm.

MECHANICAL CHARACTERISTICS	VALUES	UNITS
Mini centre contact retention force (axial)	27	N
Mini centre contact retention torque	Not applicable	N.cm
Mini cable retention force	Not applicable	N
Mini cable retention torque value	Not applicable	N.cm
Maximum weight	2.1	g

OTHER CHARACTERISTICS	VALUES	UNITS
Rapid change of temperature - peak value	+115	°C
Operating temperature range	-65 to +105	°C
Maxi leakage (panel sealed connectors)	Not applicable	
Maxi leakage (hermetic sealed connector)	10^{-7} (seal only)	atm.cm ³ /s
Solderability	Applicable (contact only)	
Soldering proof	Applicable	
Cables used	Not applicable	

FIGURE 2(b) - VARIANTS (CONTINUED)

VARIANT 66 - BULKHEAD JACK, SOLDER TYPE, FOR SHF 3 CABLE

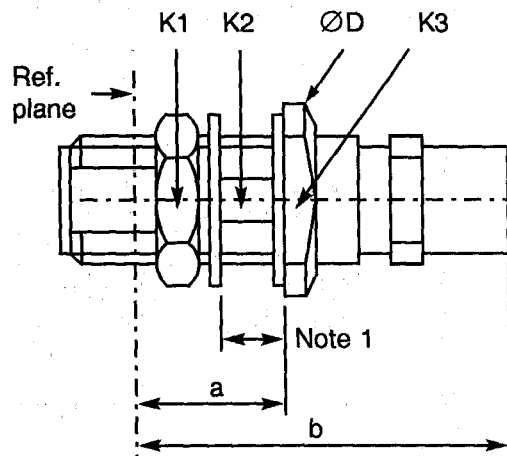

SYMBOL	MILLIMETRES		NOTES
	MIN.	MAX.	
a	10.40	10.80	
b	25.05	27.10	
ØD	11.80	12.20	
K1	-	8.00	Hexagon
K2	-	5.90	1 flat
K3	-	11.00	2 flats

NOTES

1. Maximum panel thickness: 2.30mm.

ELECTRICAL CHARACTERISTICS	VALUES	UNITS
Frequency range	0 to 17	GHz
Maximum voltage standing wave ratio (VSWR)	1.15	
Maximum reflection coefficient	0.069	
Maximum insertion loss	$0.06 \sqrt{f}$ (GHz)	dB
RF leakage	- [95 - f (GHz)]	dB
Voltage proof	750	Vrms
Corona level	190	Vrms

MECHANICAL CHARACTERISTICS	VALUES	UNITS
Mini centre contact retention force (axial)	Not applicable	N
Mini centre contact retention torque	Not applicable	N.cm
Mini cable retention force	30	N
Mini cable retention torque value	Not applicable	N.cm
Maximum weight	7.0	g

OTHER CHARACTERISTICS	VALUES	UNITS
Rapid change of temperature - peak value	+ 165	°C
Operating temperature range	- 65 to + 165	°C
Maxi leakage (panel sealed connectors)	Not applicable	
Maxi leakage (hermetic sealed connector)	Not applicable	
Solderability	Applicable	
Soldering proof	Applicable	
Cables used	F1703.143	

FIGURE 2(b) - VARIANTS (CONTINUED)

VARIANT 67 - BULKHEAD JACK, SOLDER TYPE, FOR SHF 8 CABLE

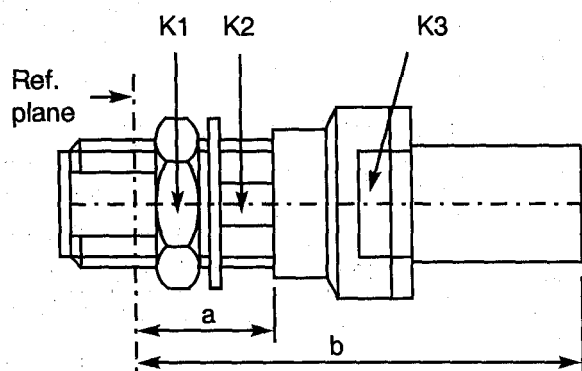

SYMBOL	MILLIMETRES		NOTES
	MIN.	MAX.	
a	11.80	12.20	
b	40.85	42.40	
K1	-	8.00	Hexagon
K2	-	5.90	1 flat
K3	-	13.00	2 flats

ELECTRICAL CHARACTERISTICS	VALUES	UNITS
Frequency range	0 to 18	GHz
Maximum voltage standing wave ratio (VSWR)	1.15	
Maximum reflection coefficient	0.069	
Maximum insertion loss	$0.06\sqrt{f}$ (GHz)	dB
RF leakage	- [95 - f (GHz)]	dB
Voltage proof	1000	Vrms
Corona level	250	Vrms

MECHANICAL CHARACTERISTICS	VALUES	UNITS
Mini centre contact retention force (axial)	Not applicable	N
Mini centre contact retention torque	Not applicable	N.cm
Mini cable retention force	50	N
Mini cable retention torque value	Not applicable	N.cm
Maximum weight	25.3	g

OTHER CHARACTERISTICS	VALUES	UNITS
Rapid change of temperature - peak value	+ 165	°C
Operating temperature range	-65 to +165	°C
Maxi leakage (panel sealed connectors)	Not applicable	
Maxi leakage (hermetic sealed connector)	Not applicable	
Solderability	Applicable	
Soldering proof	Applicable	
Cables used	F1703.148	

FIGURE 2(b) - VARIANTS (CONTINUED)

**VARIANT 68 - STRAIGHT JACK, SOLDER TYPE, BACK MOUNTING, FLANGE-MOUNTED,
FOR SEMI-RIGID CABLE Ø2.20mm (0.085")**

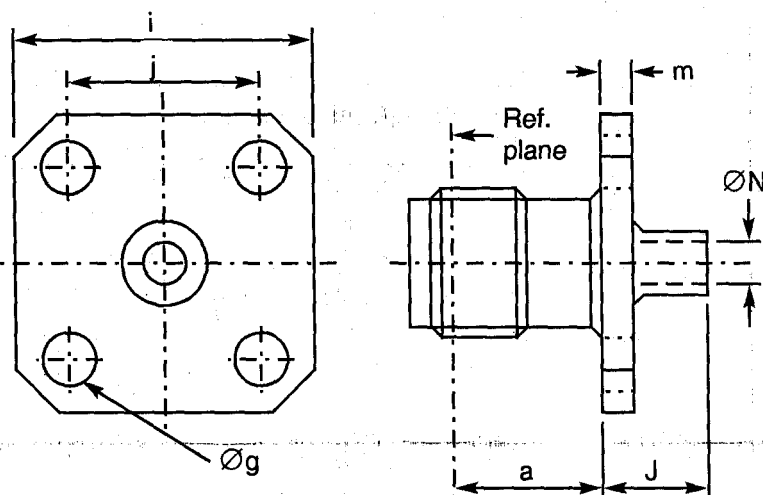

SYMBOL	MILLIMETRES		NOTES
	MIN.	MAX.	
a	5.87	6.12	4 holes
Øg	2.55	2.70	
i	12.60	12.80	
j	8.59	8.69	
J	4.60	5.00	
m	1.40	1.80	
ØN	2.25	2.35	

NOTES

1. Maximum panel thickness: 2.30mm.

ELECTRICAL CHARACTERISTICS	VALUES	UNITS
Frequency range	0 to 18	GHz
Maximum voltage standing wave ratio (VSWR)	$1.10 + 0.01 f$ (GHz)	
Maximum reflection coefficient	$0.047 + 0.004 f$ (GHz)	
Maximum insertion loss	$0.02 \sqrt{f}$ (GHz)	dB
RF leakage	$- [100 - f]$ (GHz)	dB
Voltage proof	750	Vrms
Corona level	190	Vrms

MECHANICAL CHARACTERISTICS	VALUES	UNITS
Mini centre contact retention force (axial)	Not applicable	N
Mini centre contact retention torque	Not applicable	N.cm
Mini cable retention force	200	N
Mini cable retention torque value	11.5	N.cm
Maximum weight	4.0	g

OTHER CHARACTERISTICS	VALUES	UNITS
Rapid change of temperature - peak value	+200	°C
Operating temperature range	-65 to +165	°C
Maxi leakage (panel sealed connectors)	Not applicable	
Maxi leakage (hermetic sealed connector)	Not applicable	
Solderability	Applicable	
Soldering proof	Not applicable	
Cables used	KS 1, RG 405/U (Ø2.20mm)	

FIGURE 2(b) - VARIANTS (CONTINUED)

**VARIANT 69 - STRAIGHT JACK, SOLDER TYPE, BACK MOUNTING, FLANGE-MOUNTED,
FOR SEMI-RIGID CABLE Ø3.58mm (0.141")**

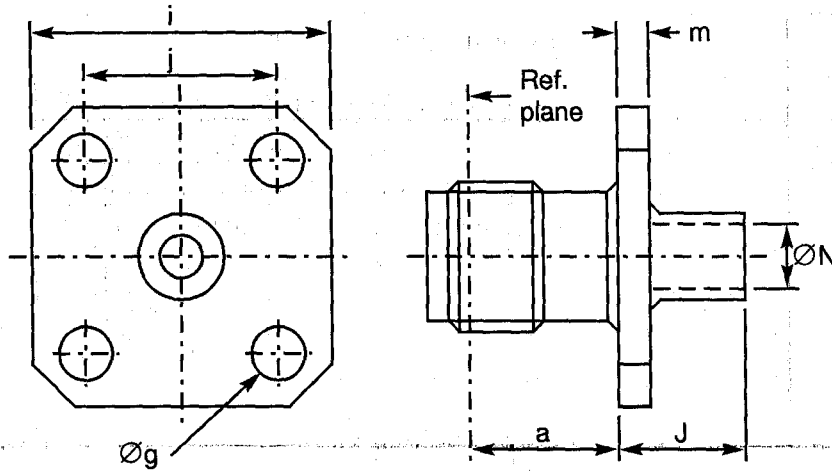

SYMBOL	MILLIMETRES		NOTES
	MIN.	MAX.	
a	5.87	6.12	4 holes
Øg	2.55	2.70	
i	12.60	12.80	
j	8.59	8.69	
J	4.60	5.00	
m	1.40	1.80	
ØN	3.65	3.75	

NOTES

1. Maximum panel thickness: 2.30mm.

ELECTRICAL CHARACTERISTICS	VALUES	UNITS
Frequency range	0 to 18	GHz
Maximum voltage standing wave ratio (VSWR)	$1.05 + 0.04 f$ (GHz)	
Maximum reflection coefficient	$0.024 + 0.0018 f$ (GHz)	
Maximum insertion loss	$0.02 \sqrt{f}$ (GHz)	dB
RF leakage	$- [100 - f]$ (GHz)	dB
Voltage proof	1000	Vrms
Corona level	250	Vrms

MECHANICAL CHARACTERISTICS	VALUES	UNITS
Mini centre contact retention force (axial)	Not applicable	N
Mini centre contact retention torque	Not applicable	N.cm
Mini cable retention force	500	N
Mini cable retention torque value	39.6	N.cm
Maximum weight	4.0	g

OTHER CHARACTERISTICS	VALUES	UNITS
Rapid change of temperature - peak value	+ 200	°C
Operating temperature range	- 65 to + 165	°C
Maxi leakage (panel sealed connectors)	Not applicable	
Maxi leakage (hermetic sealed connector)	Not applicable	
Solderability	Applicable	
Soldering proof	Not applicable	
Cables used	KS 2, RG 402/U (Ø3.58mm)	

FIGURE 2(b) - VARIANTS (CONTINUED)

VARIANT 70 - STRAIGHT JACK, CRIMP-TYPE

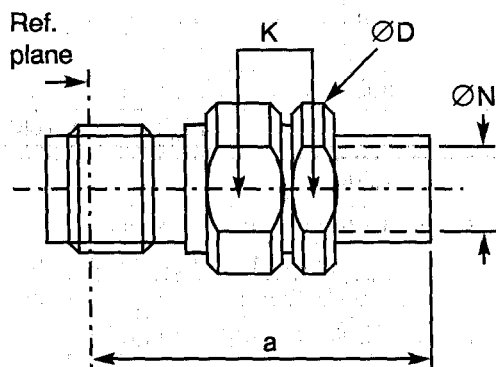

SYMBOL	MILLIMETRES		NOTES
	MIN.	MAX.	
a	22.70	24.15	
ØD	7.50	7.90	
K	-	7.00	2 flats
ØN	2.00	2.20	

ELECTRICAL CHARACTERISTICS	VALUES	UNITS
Frequency range	0 to 12.4	GHz
Maximum voltage standing wave ratio (VSWR)	$1.05 + 0.015 f$ (GHz)	
Maximum reflection coefficient	$0.047 + 0.0063 f$ (GHz)	
Maximum insertion loss	$0.03 \sqrt{f}$ (GHz)	dB
RF leakage	$- [95 - f$ (GHz)]	dB
Voltage proof	750	Vrms
Corona level	190	Vrms

MECHANICAL CHARACTERISTICS	VALUES	UNITS
Mini centre contact retention force (axial)	27	N
Mini centre contact retention torque	0.5	N.cm
Mini cable retention force	80	N
Mini cable retention torque value	$2 \times 180^\circ$ applic. point $50 \times \text{ØN}$	
Maximum weight	4.5	g

OTHER CHARACTERISTICS	VALUES	UNITS
Rapid change of temperature - peak value	+200 (see cables used)	°C
Operating temperature range	-65 to +165	°C
Maxi leakage (panel sealed connectors)	Not applicable	
Maxi leakage (hermetic sealed connector)	Not applicable	
Solderability	Applicable	
Soldering proof	Not applicable	
Cables used	50 CIS	

FIGURE 2(b) - VARIANTS (CONTINUED)

VARIANT 71 - ELBOW RECEPTACLE, SQUARE FLANGE (SOLID CONTACT)

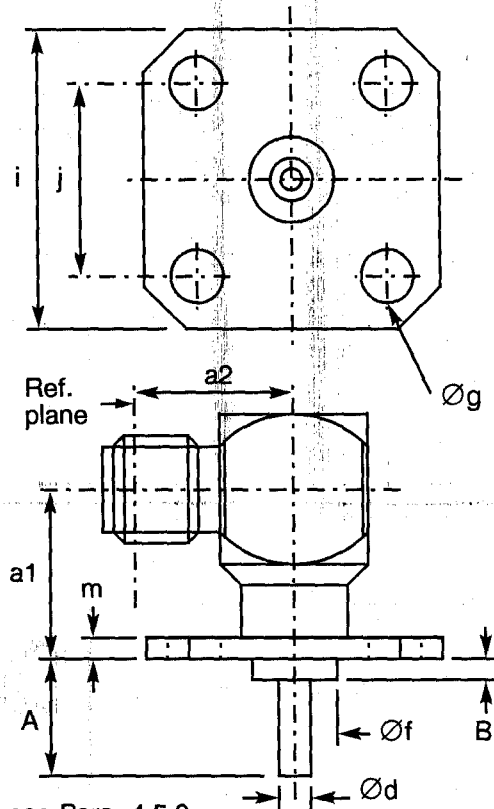

SYMBOL	MILLIMETRES		NOTES
	MIN.	MAX.	
a1	7.90	8.10	
a2	9.20	9.40	
A	-	25.00	Note 1
B	-	20.00	Note 1
Ød	1.25	1.30	
Øf	4.00	4.20	
Øg	2.55	2.70	4 holes
i	12.60	12.80	
j	8.59	8.69	
m	1.40	1.80	

NOTES

1. To specify dimensions, see Para. 4.5.3.
2. For information only.

ELECTRICAL CHARACTERISTICS	VALUES	UNITS
Frequency range	0 to 18	GHz
Maximum voltage standing wave ratio (VSWR) (2)	$1.05 + 0.01 f$ (GHz)	
Maximum reflection coefficient (2)	$0.024 + 0.004 f$ (GHz)	
Maximum insertion loss (2)	$0.03 \sqrt{f}$ (GHz)	dB
RF leakage (2)	$- [95 - f]$ (GHz)	dB
Voltage proof	1000	Vrms
Corona level	Not applicable	Vrms

MECHANICAL CHARACTERISTICS	VALUES	UNITS
Mini centre contact retention force (axial)	27	N
Mini centre contact retention torque	2.8	N.cm
Mini cable retention force	Not applicable	N
Mini cable retention torque value	Not applicable	N.cm
Maximum weight	4.9	g

OTHER CHARACTERISTICS	VALUES	UNITS
Rapid change of temperature - peak value	+115	°C
Operating temperature range	-65 to +105	°C
Maxi leakage (panel sealed connectors)	Not applicable	
Maxi leakage (hermetic sealed connector)	Not applicable	
Solderability	On centre contact only	
Soldering proof	Applicable	
Cables used	Not applicable	

FIGURE 2(b) - VARIANTS (CONTINUED)

VARIANT 72 - SQUARE FLANGE RECEPTACLE TAB CONTACT, LOW RF LEAKAGE

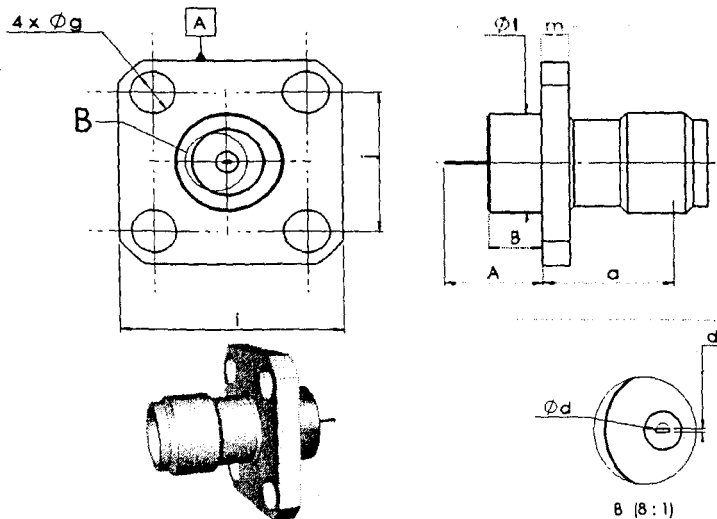

SYMBOL	MILLIMETRES		NOTES
	MIN.	MAX.	
a	7.50	7.70	
A	5.70	5.90	
B	3.13	3.32	
d	0.11	0.15	Tab thickness
Ød	0.45	0.55	
Øf	6.05	6.15	
Øg	2.55	2.70	4 holes
i	12.60	12.80	
j	8.59	8.69	
m	1.40	1.80	

ELECTRICAL CHARACTERISTICS	VALUES	UNITS
Frequency range	0 to 18	GHz
Maximum voltage standing wave ration (VSWR) ⁽¹⁾	$1.10 + 0.001 \times F \text{ (GHz)}$	-
Maximum voltage standing wave ration (VSWR) ⁽¹⁾⁽²⁾	$1.05 + 0.005 \times F \text{ (GHz)}$	-
Maximum insertion loss ⁽¹⁾	$0.05 \times \sqrt{F} \text{ (GHz)}$	dB
Maximum insertion loss ⁽¹⁾⁽²⁾	$0.03 \times \sqrt{F} \text{ (GHz)}$	dB
RF leakage ⁽¹⁾	- [120 - F (GHz)]	dB
Voltage proof	1000	Vrms
Corona level	Not Applicable	Vrms

Notes:

- (1) : For information only
(2) : Between 0 to 5GHz only.

MECHANICAL CHARACTERISTICS	VALUES	UNITS
Mini centre contact retention force (axial)	27	N
Mini centre contact retention torque	2.8	N.cm
Mini cable retention force	Not Applicable	N
Mini cable retention torque value	Not Applicable	N.cm
Maximum weight	3.5	g

OTHER CHARACTERISTICS	VALUES	UNITS
Rapid change of temperature (peak)	+115	°C
Operating temperature range	-65 to +105	°C
Maxi leakage (panel sealed connectors)	Not Applicable	-
Maxi leakage (hermetic sealed connector)	Not Applicable	-
Solderability	On centre contact only	-
Soldering proof	Applicable	-
Cable used	Not Applicable	-

FIGURE 2(b) - VARIANTS (CONTINUED)

VARIANT 73 - SQUARE FLANGE RECEPTACLE, FRONT MOUNTING

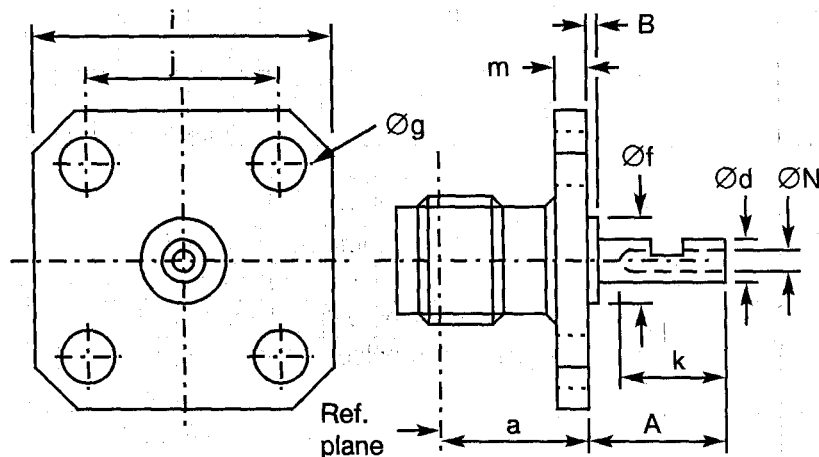

Solder Bucket -
Optional Shapes:

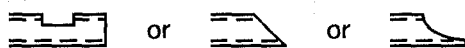

SYMBOL	MILLIMETRES		NOTES
	MIN.	MAX.	
a	7.50	7.70	
A	-	35.00	Note 1
B	-	20.00	Note 1
Ød	1.24	1.30	
Øf	4.00	4.20	
Øg	2.55	2.70	4 holes
i	12.60	12.80	
j	8.59	8.69	
k	2.40	-	
m	-1.40	1.80	
ØN	0.70	1.00	

ELECTRICAL CHARACTERISTICS		VALUES	UNITS
Frequency range		0 to 18	GHz
Maximum voltage standing wave ratio (VSWR) (2)		$1.05 + 0.003 f$ (GHz)	
Maximum reflection coefficient (2)		$0.024 + 0.0013 f$ (GHz)	
Maximum insertion loss (2)		$0.03\sqrt{f}$ (GHz)	dB
RF leakage (2)		$- [95 - f$ (GHz)]	dB
Voltage proof		1000	Vrms
Corona level		Not applicable	Vrms

NOTES

1. To specify dimensions, see Para. 4.5.3.
2. For information only.

MECHANICAL CHARACTERISTICS		VALUES	UNITS
Mini centre contact retention force (axial)		27	N
Mini centre contact retention torque		2.8	N.cm
Mini cable retention force		Not applicable	N
Mini cable retention torque value		Not applicable	N.cm
Maximum weight		3.0	g

OTHER CHARACTERISTICS		VALUES	UNITS
Rapid change of temperature - peak value		+ 180	°C
Operating temperature range		- 65 to + 165	°C
Maxi leakage (panel sealed connectors)		Not applicable	
Maxi leakage (hermetic sealed connector)		Not applicable	
Solderability		On centre contact only	
Soldering proof		Applicable	
Cables used		Not applicable	

FIGURE 2(b) - VARIANTS (CONTINUED)

VARIANT 74 - 2-HOLE FLANGE RECEPTACLE, FRONT MOUNTING

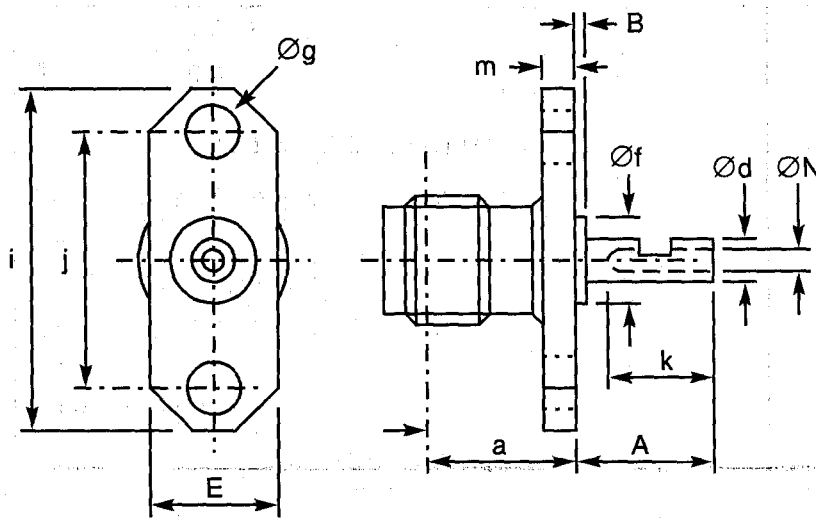

Solder Bucket -
Optional Shapes:

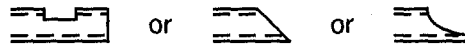

SYMBOL	MILLIMETRES		NOTES
	MIN.	MAX.	
a	7.50	7.70	
A	-	35.00	Note 1
B	-	20.00	Note 1
Ød	1.24	1.30	
E	5.50	5.80	
Øf	4.00	4.20	
Øg	2.55	2.70	2 holes
i	15.90	16.10	
j	12.10	12.30	
k	2.40	-	
m	1.40	1.80	
ØN	0.70	1.00	

ELECTRICAL CHARACTERISTICS		VALUES	UNITS
Frequency range		0 to 18	GHz
Maximum voltage standing wave ratio (VSWR)	(2)	$1.05 + 0.003 f$ (GHz)	
Maximum reflection coefficient	(2)	$0.047 + 0.0013 f$ (GHz)	
Maximum insertion loss	(2)	$0.03 \sqrt{f}$ (GHz)	dB
RF leakage	(2)	$- [95 - f]$ (GHz)	dB
Voltage proof		1000	Vrms
Corona level		Not applicable	Vrms

NOTES

- To specify dimensions, see Para. 4.5.3.
- For information only.

MECHANICAL CHARACTERISTICS		VALUES	UNITS
Mini centre contact retention force (axial)		27	N
Mini centre contact retention torque		2.8	N.cm
Mini cable retention force		Not applicable	N
Mini cable retention torque value		Not applicable	N.cm
Maximum weight		2.3	g

OTHER CHARACTERISTICS		VALUES	UNITS
Rapid change of temperature - peak value		+ 180	°C
Operating temperature range		- 65 to + 165	°C
Maxi leakage (panel sealed connectors)		Not applicable	
Maxi leakage (hermetic sealed connector)		Not applicable	
Solderability		On centre contact only	
Soldering proof		Applicable	
Cables used		Not applicable	

FIGURE 2(b) - VARIANTS (CONTINUED)

VARIANT 75 - 2-HOLE FLANGE RECEPTACLE FOR MICRO-STRIP, FRONT MOUNTING

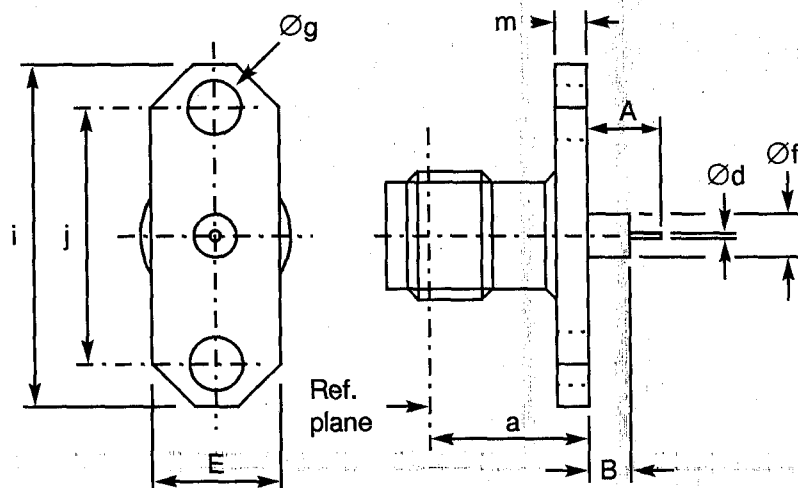

SYMBOL	MILLIMETRES		NOTES
	MIN.	MAX.	
a	7.50	7.60	2 holes
A	4.50	5.00	
B	3.05	3.30	
Ød	0.20	0.30	
E	5.50	5.80	
Øf	2.10	2.20	
Øg	2.55	2.70	
i	15.90	16.10	
j	12.10	12.30	
m	1.40	1.80	

ELECTRICAL CHARACTERISTICS	VALUES	UNITS
Frequency range	0 to 12.4	GHz
Maximum voltage standing wave ratio (VSWR) (1)	$1.04 + 0.018 f$ (GHz)	
Maximum reflection coefficient (1)	$0.019 + 0.0074 f$ (GHz)	
Maximum insertion loss (1)	$0.03 \sqrt{f}$ (GHz)	dB
RF leakage (1)	$- [95 - f]$ (GHz)	dB
Voltage proof	1000	Vrms
Corona level	Not applicable	Vrms

NOTES

1. For information only.

MECHANICAL CHARACTERISTICS	VALUES	UNITS
Mini centre contact retention force (axial)	27	N
Mini centre contact retention torque	2.8	N.cm
Mini cable retention force	Not applicable	N
Mini cable retention torque value	Not applicable	N.cm
Maximum weight	2.3	g

OTHER CHARACTERISTICS	VALUES	UNITS
Rapid change of temperature - peak value	+ 180	°C
Operating temperature range	- 65 to + 165	°C
Maxi leakage (panel sealed connectors)	Not applicable	
Maxi leakage (hermetic sealed connector)	Not applicable	
Solderability	On centre contact only	
Soldering proof	Applicable	
Cables used	Not applicable	

FIGURE 2(b) - VARIANTS (CONTINUED)

VARIANT 76 - SQUARE FLANGE RECEPTACLE FOR MICRO-STRIP, FRONT MOUNTING

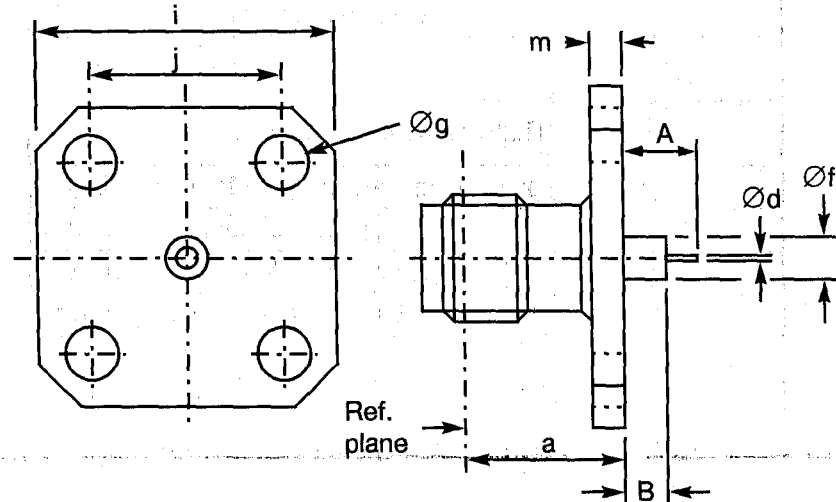

SYMBOL	MILLIMETRES		NOTES
	MIN.	MAX.	
a	7.50	7.60	4 holes
A	4.60	4.90	
B	3.05	3.30	
Ød	0.20	0.30	
Øf	2.10	2.20	
Øg	2.55	2.70	
i	12.60	12.80	
j	8.59	8.69	
m	1.40	1.80	

ELECTRICAL CHARACTERISTICS		VALUES	UNITS
Frequency range		0 to 12.4	GHz
Maximum voltage standing wave ratio (VSWR)	(1)	$1.04 + 0.018 f$ (GHz)	
Maximum reflection coefficient	(1)	$0.019 + 0.0074 f$ (GHz)	
Maximum insertion loss	(1)	$0.03 \sqrt{f}$ (GHz)	dB
RF leakage	(1)	$- [95 - f]$ (GHz)	dB
Voltage proof		1000	V _{rms}
Corona level		Not applicable	V _{rms}

NOTES

- For information only.

MECHANICAL CHARACTERISTICS		VALUES	UNITS
Mini centre contact retention force (axial)		27	N
Mini centre contact retention torque		2.8	N.cm
Mini cable retention force		Not applicable	N
Mini cable retention torque value		Not applicable	N.cm
Maximum weight		3.0	g

OTHER CHARACTERISTICS		VALUES	UNITS
Rapid change of temperature - peak value		+ 180	°C
Operating temperature range		- 65 to + 165	°C
Maxi leakage (panel sealed connectors)		Not applicable	
Maxi leakage (hermetic sealed connector)		Not applicable	
Solderability		On centre contact only	
Soldering proof		Applicable	
Cables used		Not applicable	

FIGURE 2(b) - VARIANTS (CONTINUED)

VARIANT 77 - SQUARE FLANGE RECEPTACLE

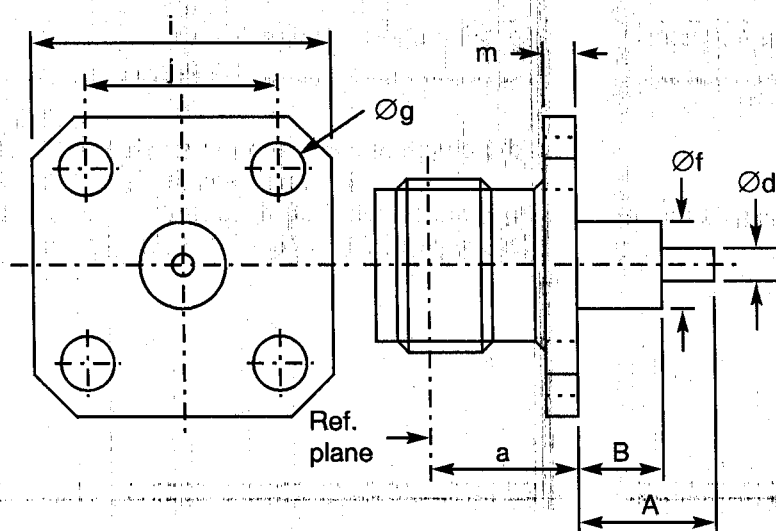

SYMBOL	MILLIMETRES		NOTES
	MIN.	MAX.	
a	7.50	7.70	
A	-	40.10	Note 1
B	-	20.00	Note 1
Ød	1.25	1.30	
Øf	4.00	4.20	
Øg	2.55	2.70	4 holes
i	12.60	12.80	
j	8.59	8.69	
m	1.40	1.80	

ELECTRICAL CHARACTERISTICS	VALUES	UNITS
Frequency range	0 to 18	GHz
Maximum voltage standing wave ratio (VSWR) (2)	$1.05 + 0.003 f$ (GHz)	
Maximum reflection coefficient (2)	$0.024 + 0.0013 f$ (GHz)	
Maximum insertion loss (2)	$0.03 \sqrt{f}$ (GHz)	dB
RF leakage (2)	$- [95 - f]$ (GHz)	dB
Voltage proof	1000	Vrms
Corona level	Not applicable	Vrms

NOTES

- To specify dimensions, see Para. 4.5.3.
- For information only.

MECHANICAL CHARACTERISTICS	VALUES	UNITS
Mini centre contact retention force (axial)	27	N
Mini centre contact retention torque	2.8	N.cm
Mini cable retention force	Not applicable	N
Mini cable retention torque value	Not applicable	N.cm
Maximum weight	5.0	g

OTHER CHARACTERISTICS	VALUES	UNITS
Rapid change of temperature - peak value	+180	°C
Operating temperature range	-65 to +165	°C
Maxi leakage (panel sealed connectors)	Not applicable	
Maxi leakage (hermetic sealed connector)	Not applicable	
Solderability	On centre contact only	
Soldering proof	Applicable	
Cables used	Not applicable	

FIGURE 2(b) - VARIANTS (CONTINUED)

VARIANT 78 - 2-HOLE FLANGE RECEPTACLE

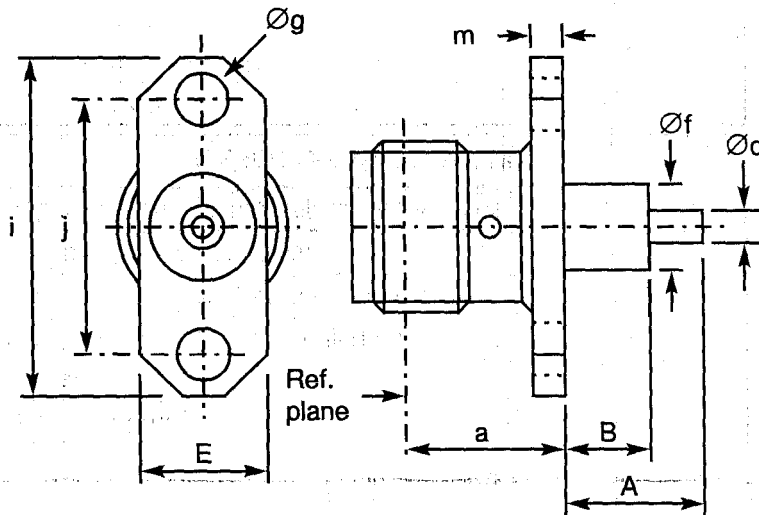

SYMBOL	MILLIMETRES		NOTES
	MIN.	MAX.	
a	7.50	7.60	
A	-	40.10	Note 1
B	-	20.00	Note 1
Ød	1.25	1.30	
E	5.50	5.80	
Øf	4.00	4.20	
Øg	2.55	2.70	2 holes
i	15.90	16.10	
j	12.10	12.30	
m	1.40	1.80	

ELECTRICAL CHARACTERISTICS	VALUES	UNITS
Frequency range	0 to 18	GHz
Maximum voltage standing wave ratio (VSWR) (2)	$1.05 + 0.003 f$ (GHz)	
Maximum reflection coefficient (2)	$0.024 + 0.0013 f$ (GHz)	
Maximum insertion loss (2)	$0.03 \sqrt{f}$ (GHz)	dB
RF leakage (2)	$- [95 - f$ (GHz)]	dB
Voltage proof	1000	Vrms
Corona level	Not applicable	Vrms

NOTES

1. To specify dimensions, see Para. 4.5.3.
2. For information only.

MECHANICAL CHARACTERISTICS	VALUES	UNITS
Mini centre contact retention force (axial)	27	N
Mini centre contact retention torque	2.8	N.cm
Mini cable retention force	Not applicable	N
Mini cable retention torque value	Not applicable	N.cm
Maximum weight	4.0	g

OTHER CHARACTERISTICS	VALUES	UNITS
Rapid change of temperature - peak value	+ 180	°C
Operating temperature range	- 65 to + 165	°C
Maxi leakage (panel sealed connectors)	Not applicable	
Maxi leakage (hermetic sealed connector)	Not applicable	
Solderability	On centre contact only	
Soldering proof	Applicable	
Cables used	Not applicable	

FIGURE 2(b) - VARIANTS (CONTINUED)

VARIANT 79 - SQUARE FLANGE RECEPTACLE

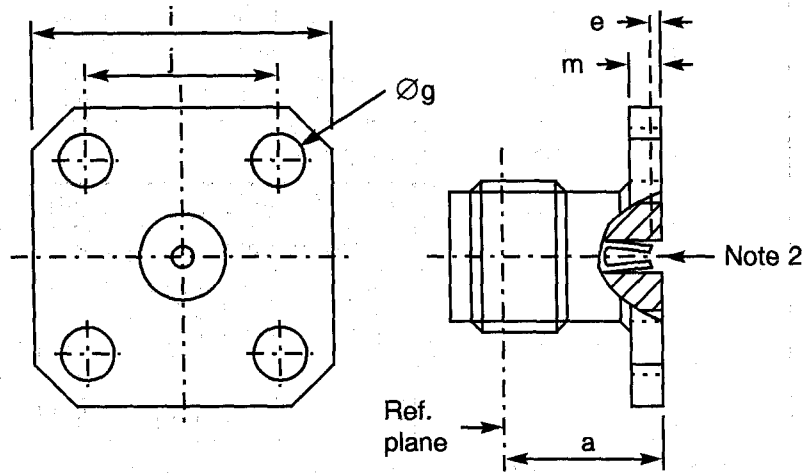

SYMBOL	MILLIMETRES		NOTES
	MIN.	MAX.	
a	7.50	7.70	
e	0.18	0.41	
Øg	2.55	2.70	4 holes
i	12.60	12.80	
j	8.59	8.69	
m	1.40	1.80	

ELECTRICAL CHARACTERISTICS	VALUES	UNITS
Frequency range	0 to 18	GHz
Maximum voltage standing wave ratio (VSWR)	$1.06 + 0.007 f$ (GHz)	
Maximum reflection coefficient	$0.029 + 0.0031 f$ (GHz)	
Maximum insertion loss (1)	$0.03 \sqrt{f}$ (GHz)	dB
RF leakage (1)	$- [95 - f]$ (GHz)	dB
Voltage proof	1000	Vrms
Corona level	Not applicable	Vrms

NOTES

- For information only.
- Contact engagement and separation forces shall be measured on the rear contact (see Para. 4.3.8).

MECHANICAL CHARACTERISTICS	VALUES	UNITS
Mini centre contact retention force (axial)	27	N
Mini centre contact retention torque	Not applicable	N.cm
Mini cable retention force	Not applicable	N
Mini cable retention torque value	Not applicable	N.cm
Maximum weight	3.0	g

OTHER CHARACTERISTICS	VALUES	UNITS
Rapid change of temperature - peak value	+ 180	°C
Operating temperature range	- 65 to + 165	°C
Maxi leakage (panel sealed connectors)	Not applicable	
Maxi leakage (hermetic sealed connector)	Not applicable	
Solderability	Not applicable	
Soldering proof	Not applicable	
Cables used	Not applicable	

FIGURE 2(b) - VARIANTS (CONTINUED)

VARIANT 80 - 2-HOLE FLANGE RECEPTACLE

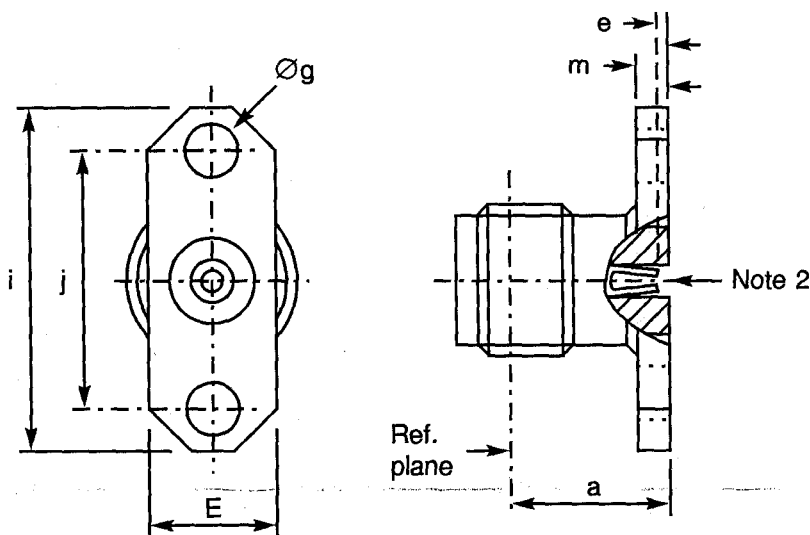

SYMBOL	MILLIMETRES		NOTES
	MIN.	MAX.	
a	7.50	7.60	2 holes
e	0.18	0.41	
E	5.50	5.80	
Øg	2.55	2.70	
i	15.90	16.10	
j	12.10	12.30	
m	1.40	1.80	

ELECTRICAL CHARACTERISTICS	VALUES	UNITS
Frequency range	0 to 18	GHz
Maximum voltage standing wave ratio (VSWR)	$1.06 + 0.006 f$ (GHz)	
Maximum reflection coefficient	$0.029 + 0.0026 f$ (GHz)	
Maximum insertion loss (1)	$0.03 \sqrt{f}$ (GHz)	dB
RF leakage (1)	$-[95 - f]$ (GHz)	dB
Voltage proof	1000	Vrms
Corona level	Not applicable	Vrms

NOTES

- For information only.
- Contact engagement and separation forces shall be measured on the rear contact (see Para. 4.3.8).

MECHANICAL CHARACTERISTICS	VALUES	UNITS
Mini centre contact retention force (axial)	27	N
Mini centre contact retention torque	2.8	N.cm
Mini cable retention force	Not applicable	N
Mini cable retention torque value	Not applicable	N.cm
Maximum weight	2.3	g

OTHER CHARACTERISTICS	VALUES	UNITS
Rapid change of temperature - peak value	+180	°C
Operating temperature range	-65 to +165	°C
Maxi leakage (panel sealed connectors)	Not applicable	
Maxi leakage (hermetic sealed connector)	Not applicable	
Solderability	Not applicable	
Soldering proof	Not applicable	
Cables used	Not applicable	

FIGURE 2(b) - VARIANTS (CONTINUED)

VARIANT 81 - SQUARE FLANGE RECEPTACLE, LOW RF LEAKAGE

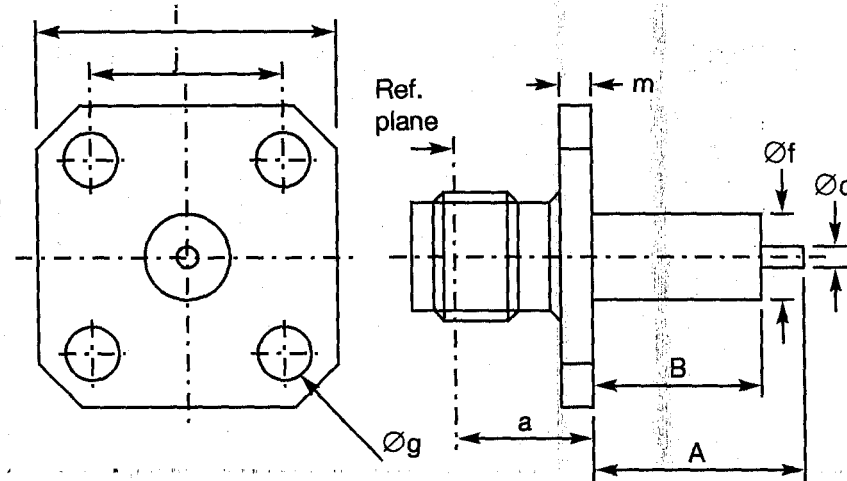

SYMBOL	MILLIMETRES		NOTES
	MIN.	MAX.	
a	7.50	7.70	
A	-	35.00	Note 1
B	-	20.00	Note 1
Ød	1.25	1.30	
Øf	4.00	4.20	
Øg	2.55	2.70	4 holes
i	12.60	12.80	
j	8.59	8.69	
m	1.40	1.80	

ELECTRICAL CHARACTERISTICS	VALUES	UNITS
Frequency range	0 to 18	GHz
Maximum voltage standing wave ratio (VSWR) (2)	1.05 + 0.003 f (GHz)	
Maximum reflection coefficient (2)	0.024 + 0.0013 f (GHz)	
Maximum insertion loss (2)	0.03√f (GHz)	dB
RF leakage (2)	-120 at 10 GHz	dB
Voltage proof	1000	Vrms
Corona level	Not applicable	Vrms

NOTES

1. To specify dimensions, see Para. 4.5.3.
2. For information only.

MECHANICAL CHARACTERISTICS	VALUES	UNITS
Mini centre contact retention force (axial)	27	N
Mini centre contact retention torque	2.8	N.cm
Mini cable retention force	Not applicable	N
Mini cable retention torque value	Not applicable	N.cm
Maximum weight	4.0	g

OTHER CHARACTERISTICS	VALUES	UNITS
Rapid change of temperature - peak value	+180	°C
Operating temperature range	-65 to +165	°C
Maxi leakage (panel sealed connectors)	Not applicable	
Maxi leakage (hermetic sealed connector)	Not applicable	
Solderability	On centre contact only	
Soldering proof	Applicable	
Cables used	Not applicable	

FIGURE 2(b) - VARIANTS (CONTINUED)

VARIANT 82 - 2-HOLE FLANGE RECEPTACLE, LOW RF LEAKAGE

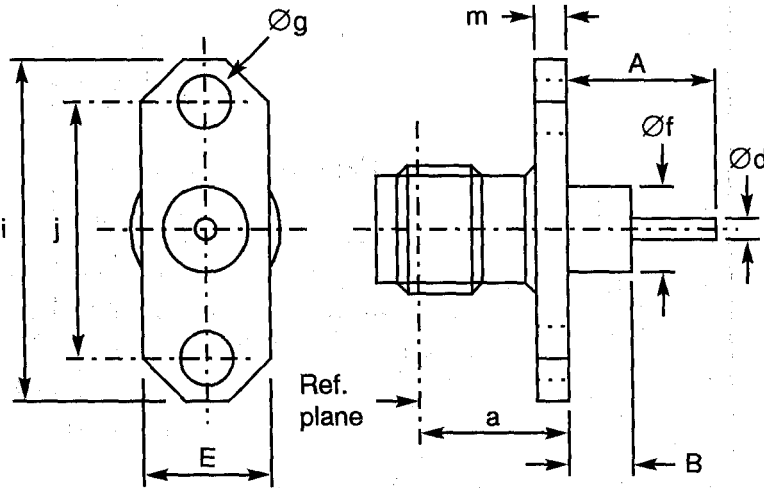

SYMBOL	MILLIMETRES		NOTES
	MIN.	MAX.	
a	7.50	7.70	
A	-	40.10	Note 2
B	-	20.00	Note 2
Ød	1.25	1.30	
E	5.50	5.80	
Øf	4.00	4.20	
Øg	2.55	2.70	2 holes
i	15.90	16.10	
j	12.10	12.30	
m	1.40	1.80	

ELECTRICAL CHARACTERISTICS		VALUES	UNITS
Frequency range		0 to 18	GHz
Maximum voltage standing wave ratio (VSWR)	(1)	$1.05 + 0.003 f$ (GHz)	
Maximum reflection coefficient	(1)	$0.024 + 0.0013 f$ (GHz)	
Maximum insertion loss	(1)	$0.03 \sqrt{f}$ (GHz)	dB
RF leakage	(1)	-120 at 10 GHz	dB
Voltage proof		1000	Vrms
Corona level		Not applicable	Vrms

NOTES

- For information only.
- To specify dimensions, see Para. 4.5.3.

MECHANICAL CHARACTERISTICS		VALUES	UNITS
Mini centre contact retention force (axial)		27	N
Mini centre contact retention torque		2.8	N.cm
Mini cable retention force		Not applicable	N
Mini cable retention torque value		Not applicable	N.cm
Maximum weight		3.3	g

OTHER CHARACTERISTICS		VALUES	UNITS
Rapid change of temperature - peak value		+180	°C
Operating temperature range		-65 to +165	°C
Maxi leakage (panel sealed connectors)		Not applicable	
Maxi leakage (hermetic sealed connector)		Not applicable	
Solderability		On centre contact only	
Soldering proof		Applicable	
Cables used		Not applicable	

FIGURE 2(b) - VARIANTS (CONTINUED)

VARIANT 83 - BULKHEAD RECEPTACLE WITH GLASS SEAL Ø CONTACT 0.30

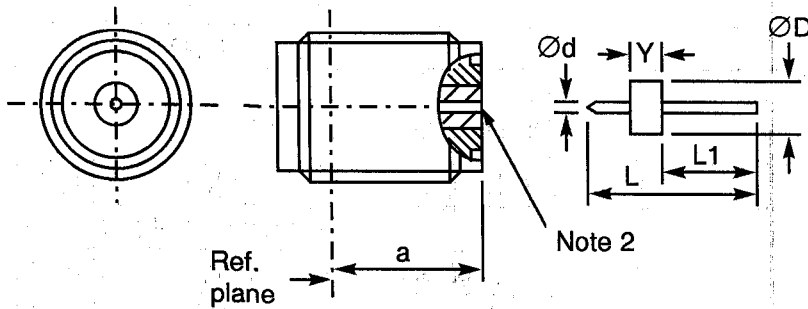

SYMBOL	MILLIMETRES		NOTES
	MIN.	MAX.	
a	7.05	8.05	
Ød	-	0.31	
ØD	-	2.53	
L	7.80	8.20	
L1	4.45	4.70	
Y	1.55	1.65	

ELECTRICAL CHARACTERISTICS	VALUES	UNITS
Frequency range	0 to 18	GHz
Maximum voltage standing wave ratio (VSWR) (1)	$1.06 + 0.01 f$ (GHz)	
Maximum reflection coefficient (1)	$0.029 + 0.0043 f$ (GHz)	
Maximum insertion loss (1)	$0.03\sqrt{f}$ (GHz)	dB
RF leakage (1)	-70	dB
Voltage proof	1000	Vrms
Corona level	Not applicable	Vrms

NOTES

- For information only.
- Accept contact Ø0.30mm.

MECHANICAL CHARACTERISTICS	VALUES	UNITS
Mini centre contact retention force (axial)	27	N
Mini centre contact retention torque	Not applicable	N.cm
Mini cable retention force	Not applicable	N
Mini cable retention torque value	Not applicable	N.cm
Maximum weight	1.7	g

OTHER CHARACTERISTICS	VALUES	UNITS
Rapid change of temperature - peak value	+180	°C
Operating temperature range	-65 to +165	°C
Maxi leakage (panel sealed connectors)	Not applicable	
Maxi leakage (hermetic sealed connector)	10^{-8} (seal only)	atm.cm ³ /s
Solderability	Applicable (contact only)	
Soldering proof	Applicable	
Cables used	Not applicable	

FIGURE 2(b) - VARIANTS (CONTINUED)

VARIANT 84 - BULKHEAD RECEPTACLE WITH GLASS SEAL Ø CONTACT 0.46

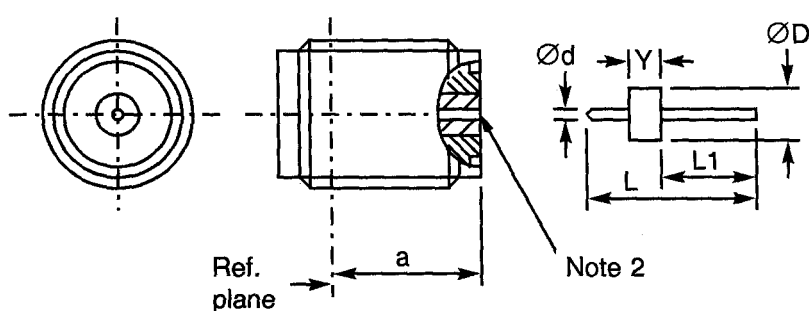

SYMBOL	MILLIMETRES		NOTES
	MIN.	MAX.	
a	7.05	8.05	
Ød	-	0.47	
ØD	-	2.86	
L	7.80	8.20	
L1	4.45	4.70	
Y	1.55	1.65	

ELECTRICAL CHARACTERISTICS	VALUES	UNITS
Frequency range	0 to 18	GHz
Maximum voltage standing wave ratio (VSWR) (1)	$1.06 + 0.01 f$ (GHz)	
Maximum reflection coefficient (1)	$0.029 + 0.0043 f$ (GHz)	
Maximum insertion loss (1)	$0.03\sqrt{f}$ (GHz)	dB
RF leakage (1)	-70	dB
Voltage proof	1000	Vrms
Corona level	Not applicable	Vrms

NOTES

1. For information only.
2. Accept contact Ø0.46mm.

MECHANICAL CHARACTERISTICS	VALUES	UNITS
Mini centre contact retention force (axial)	27	N
Mini centre contact retention torque	Not applicable	N.cm
Mini cable retention force	Not applicable	N
Mini cable retention torque value	Not applicable	N.cm
Maximum weight	1.7	g

OTHER CHARACTERISTICS	VALUES	UNITS
Rapid change of temperature - peak value	+180	°C
Operating temperature range	-65 to +165	°C
Maxi leakage (panel sealed connectors)	Not applicable	
Maxi leakage (hermetic sealed connector)	10^{-8} (seal only)	atm.cm ³ /s
Solderability	Applicable (contact only)	
Soldering proof	Applicable	
Cables used	Not applicable	

FIGURE 2(b) - VARIANTS (CONTINUED)

VARIANT 85 - ELBOW RECEPTACLE, SQUARE FLANGE (SOLID CONTACT)

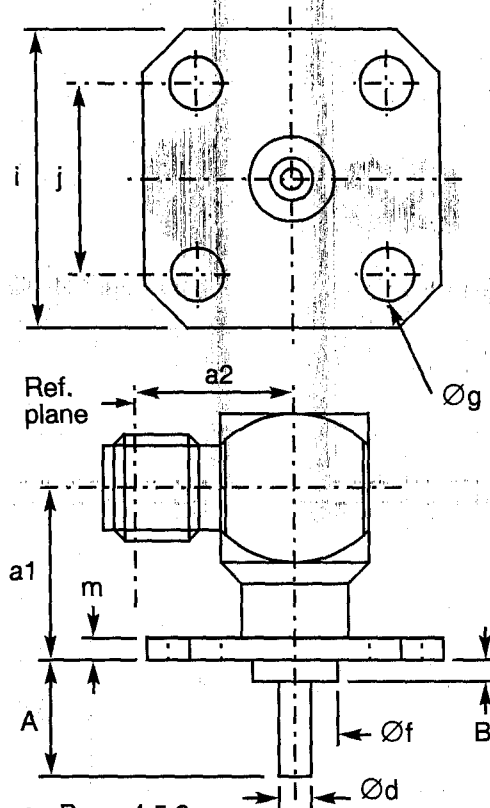

SYMBOL	MILLIMETRES		NOTES
	MIN.	MAX.	
a1	7.90	8.10	
a2	9.20	9.40	
A	-	25.00	Note 1
B	-	20.00	Note 1
Ød	1.25	1.30	
Øf	4.00	4.20	
Øg	2.55	2.70	4 holes
i	12.60	12.80	
j	8.59	8.69	
m	1.40	1.80	

NOTES

1. To specify dimensions, see Para. 4.5.3.
2. For information only.

ELECTRICAL CHARACTERISTICS		VALUES	UNITS
Frequency range		0 to 18	GHz
Maximum voltage standing wave ratio (VSWR)	(2)	$1.05 + 0.01 f$ (GHz)	
Maximum reflection coefficient	(2)	$0.024 + 0.004 f$ (GHz)	
Maximum insertion loss	(2)	$0.03 \sqrt{f}$ (GHz)	dB
RF leakage	(2)	$- [95 - f$ (GHz)]	dB
Voltage proof		1000	Vrms
Corona level		Not applicable	Vrms

MECHANICAL CHARACTERISTICS		VALUES	UNITS
Mini centre contact retention force (axial)		27	N
Mini centre contact retention torque		2.8	N.cm
Mini cable retention force		Not applicable	N
Mini cable retention torque value		Not applicable	N.cm
Maximum weight		5.3	g

OTHER CHARACTERISTICS		VALUES	UNITS
Rapid change of temperature - peak value		+ 180	°C
Operating temperature range		-65 to +165	°C
Maxi leakage (panel sealed connectors)		Not applicable	
Maxi leakage (hermetic sealed connector)		Not applicable	
Solderability		On centre contact only	
Soldering proof		Applicable	
Cables used		Not applicable	