



Pages 1 to 21

**RELAYS, ELECTROMAGNETIC, NON-LATCHING,
28Vdc, 25A, 3 PDT,
ESCC Detail Specification No. 3601/009**

**ISSUE 2
September 2004**



Document Custodian: European Space Agency - see <https://escies.org>

	ESCC Detail Specification No. 3601/009		PAGE i ISSUE 2
--	---	--	-------------------

LEGAL DISCLAIMER AND COPYRIGHT

European Space Agency, Copyright © 2004. All rights reserved.

The European Space Agency disclaims any liability or responsibility, to any person or entity, with respect to any loss or damage caused, or alleged to be caused, directly or indirectly by the use and application of this ESCC publication.

This publication, without the prior permission of the European Space Agency and provided that it is not used for a commercial purpose, may be:

- copied in whole in any medium without alteration or modification.
- copied in part, in any medium, provided that the ESCC document identification, comprising the ESCC symbol, document number and document issue, is removed.

	<p>ESCC Detail Specification No. 3601/009</p>		<p>PAGE 2 ISSUE 2</p>
---	---	--	---------------------------

DOCUMENTATION CHANGE NOTICE

(Refer to <https://escies.org> for ESCC DCR content)

DCR No.	CHANGE DESCRIPTION
130	Specification upissued to incorporate technical and editorial changes per DCR.



TABLE OF CONTENTS

	<u>Page</u>
1. <u>GENERAL</u>	5
1.1 Scope	5
1.2 Component Type Variants	5
1.3 Maximum Ratings	5
1.4 Parameter Derating Information	5
1.5 Physical Dimensions	5
1.6 Circuit Schematic	5
2. <u>APPLICABLE DOCUMENTS</u>	5
3. <u>TERMS, DEFINITIONS, ABBREVIATIONS, SYMBOLS AND UNITS</u>	5
4. <u>REQUIREMENTS</u>	13
4.1 General	13
4.2 Deviations from Generic Specification	13
4.2.1 Deviations from Special In-Process Controls	13
4.2.2 Deviations from Final Production Tests	13
4.2.3 Deviations from Screening Tests	13
4.2.4 Deviations from Qualification Tests	13
4.2.5 Deviations from Lot Acceptance Tests	13
4.3 Mechanical Requirements	14
4.3.1 Dimension Check	14
4.3.2 Weight	14
4.3.3 Terminal Strength	14
4.4 Materials and Finishes	14
4.4.1 Case	14
4.4.2 Terminal Material and Finish	14
4.5 Marking	14
4.5.1 General	14
4.5.2 Terminal Identification	14
4.5.3 The ESCC Component Number	15
4.5.4 Electrical Characteristics	15
4.5.5 Traceability Information	15
4.6 Electrical Measurements	15
4.6.1 Electrical Measurements at Room Temperature	15
4.6.2 Electrical Measurements at High and Low Temperatures	15
4.6.3 Circuits for Electrical Measurements	15
4.7 Screening	15
4.7.1 Miss Test	15
4.7.2 Conditions for Screening	15
4.7.3 Electrical Circuits for Screening	15
4.8 Environmental and Endurance Tests	19
4.8.1 Measurements and Inspections on Completion of Environmental Tests	19
4.8.2 Measurements and Inspections during Endurance Tests	19
4.8.3 Measurements and Inspections on Completion of Endurance Tests	19
4.8.4 Conditions for Operating Life Tests	19
4.8.5 Electrical Circuits for Operating Life Tests	19

	<p style="text-align: center;">ESCC Detail Specification No. 3601/009</p>		<p>PAGE 4 ISSUE 2</p>
--	---	--	---------------------------

<u>TABLES</u>	<u>Page</u>
1(a) Type Variants	6
1(b) Maximum Ratings	6
2 Electrical Measurements at Room Temperature	16
3 Electrical Measurements at High and Low Temperatures	17
4 Measurements during Screening	18
5(a) Conditions for Screening	18
5(b) Conditions for Operating Life Test	18
6 Measurements and Inspection on Completion of Environmental Tests and at Intermediate Points and on Completion of Endurance Testing	20

<u>FIGURES</u>	
1 Not applicable	
2 Physical Dimensions	7
3 Circuit Schematic	12
4 Circuits for Electrical Measurements	N/A
5(a) Electrical Circuits for Screening	N/A
5(b) Electrical Circuits for Operating Life Tests	N/A

APPENDICES (Applicable to specific Manufacturers only)
None.

	<p style="text-align: center;">ESCC Detail Specification No. 3601/009</p>		<p>PAGE 5 ISSUE 2</p>
--	---	--	---------------------------

1. GENERAL

1.1 SCOPE

This specification details the ratings, physical and electrical characteristics, test and inspection data for a Relay, Electromagnetic Non-latching, 28Vdc, 25A, 3PDT. It shall be read in conjunction with ESCC Generic Specification No. 3601, the requirements of which are supplemented herein.

1.2 COMPONENT TYPE VARIANTS

Variants of the basic type relays specified herein, which are also covered by this specification, are given in Table 1(a).

1.3 MAXIMUM RATINGS

The maximum ratings, which shall not be exceeded at any time during use or storage, applicable to the relays specified herein, are as scheduled in Table 1(b).

1.4 PARAMETER DERATING INFORMATION (Figure 1)

Not applicable.

1.5 PHYSICAL DIMENSIONS

The physical dimensions of the relays specified herein are shown in Figure 2.

1.6 CIRCUIT SCHEMATIC

The circuit schematic, showing terminal identification etc. for the relays specified herein, is shown in Figure 3.

2. APPLICABLE DOCUMENTS

The following documents form part of this specification and shall be read in conjunction with it:-

- (a) ESCC Generic Specification No. 3601 for Relays, Electromagnetic, Non-latching.
- (b) MIL-STD-202, Test Methods for Electronic and Electrical Component Parts.

3. TERMS, DEFINITIONS, ABBREVIATIONS, SYMBOLS AND UNITS

For the purpose of this specification, the terms, definitions, abbreviations, symbols and units specified in ESCC Basic Specification No. 21300 shall apply.

TABLE 1(a) - TYPE VARIANTS

VARIANT	DESCRIPTION	FIGURE
01	Not to be used	-
02	Relay with Solderable Hook-end Terminals and Horizontal Flange Mount	2(a)
03	Relay with Plug-in Terminals and Horizontal Flange Mount	2(b)
04	Relay with Solderable Hook-end Terminals and Vertical Flange Mount	2(c)
05	Relay with Plug-in Terminals and Plain Case	2(d)
06	Relay with Solderable Hook-end Terminals and Plain Case	2(e)

TABLE 1(b) - MAXIMUM RATINGS

No.	CHARACTERISTICS	SYMBOL	MAXIMUM RATING	UNIT	REMARKS
1	Rated Coil Voltage:- 28V 12V 6V	V_{CR}	28 12 6.0	Vdc	
2	Coil Voltage Range:- 28V 12V 6V	V_{CR}	26.5 to 32 11 to 14.5 5.5 to 7.3	Vdc	
3	Rated Contact Current Resistive Load	I_{CR}	25	A	28Vdc resistive Note 1
4	Overload Current Resistive	I_{over}	50	A	28Vdc resistive See Table 6
5	Rated Contact Current Inductive Load	I_{CL}	12	A	28 Vdc inductive Note 1
6	Contact Resistance	R_C	6.0	m Ω	At rated current
7	High Temperature	T_{amb}	+ 125	°C	
8	Low Temperature	T_{amb}	- 65	°C	
9	Soldering Temperature	T_{sol}	+ 260	°C	Note 2

NOTES

1. Relays should not be used in change-over mode where the potential difference between stationary contacts is greater than 10V and the switched current is greater than 0.1A.
2. Duration 10 seconds maximum at a distance of not less than 3.0mm from the device body and the same terminal shall not be resoldered until 3 minutes have elapsed.

FIGURE 2 - PHYSICAL DIMENSIONS

FIGURE 2(a) - VARIANT 02, RELAY WITH WITH SOLDERABLE HOOK-END TERMINALS AND HORIZONTAL FLANGE MOUNT

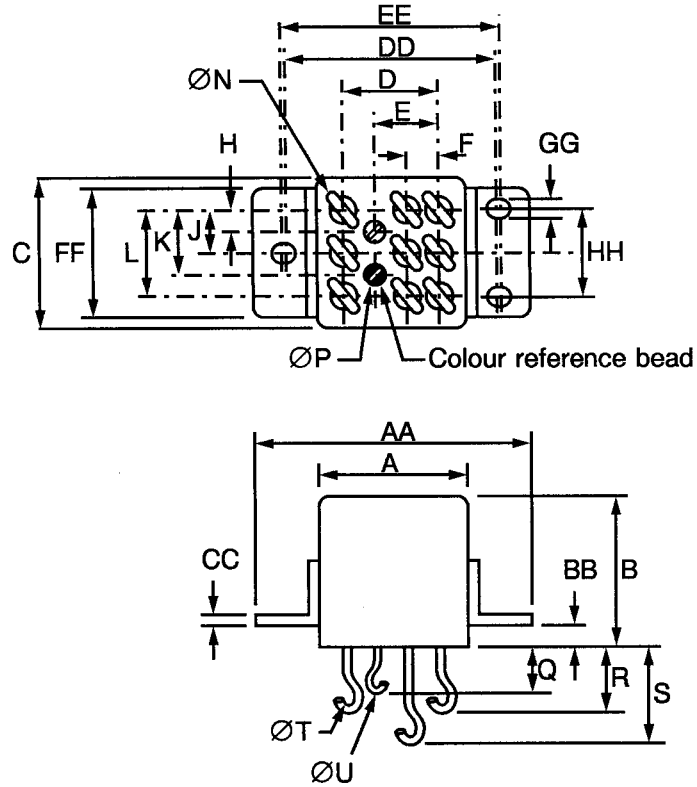

SYMBOL	MILLIMETRES	
	MIN.	MAX.
AA	-	43.60
BB	3.80	4.20
CC	0.90	1.10
DD	35.20	35.70
EE	36.45	36.95
FF	23.60	24.00
GG	3.55	4.05
HH	15.65	16.15
A	-	26.00
B	-	25.70
C	-	26.00

SYMBOL	MILLIMETRES	
	MIN.	MAX.
D	15.80	16.20
E	10.80	11.20
F	5.80	6.00
H	3.70	3.90
J	7.50	7.70
K	11.20	11.60
L	15.00	15.40
ØN	2.30	2.45
ØP	0.95	1.10
Q	7.10	8.10
R	9.00	10.00
S	15.40	16.40
ØT	2.30	2.45
ØU	0.95	1.10

FIGURE 2 - PHYSICAL DIMENSIONS (CONTINUED)

FIGURE 2(b) - VARIANT 03, RELAY WITH PLUG-IN TERMINALS AND HORIZONTAL FLANGE MOUNT

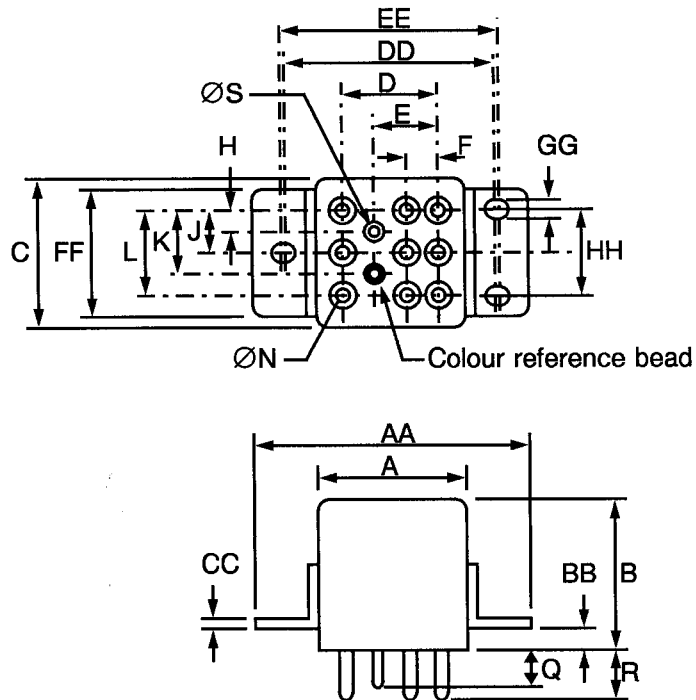

SYMBOL	MILLIMETRES	
	MIN.	MAX.
AA	-	43.60
BB	3.80	4.20
CC	0.90	1.10
DD	35.20	35.70
EE	36.45	36.95
FF	23.60	24.00
GG	3.55	4.05
HH	15.65	16.15

SYMBOL	MILLIMETRES	
	MIN.	MAX.
A	-	26.00
B	-	25.70
C	-	26.00
D	15.80	16.20
E	10.80	11.20
F	5.70	6.20
H	3.70	3.90
J	7.50	7.70
K	11.20	11.60
L	15.00	15.40
ØN	2.30	2.41
Q	6.10	6.60
R	6.60	7.10
ØS	1.55	1.61

FIGURE 2 - PHYSICAL DIMENSIONS (CONTINUED)

FIGURE 2(c) - VARIANT 04, RELAY WITH SOLDERABLE HOOK-END TERMINALS AND VERTICAL FLANGE MOUNT

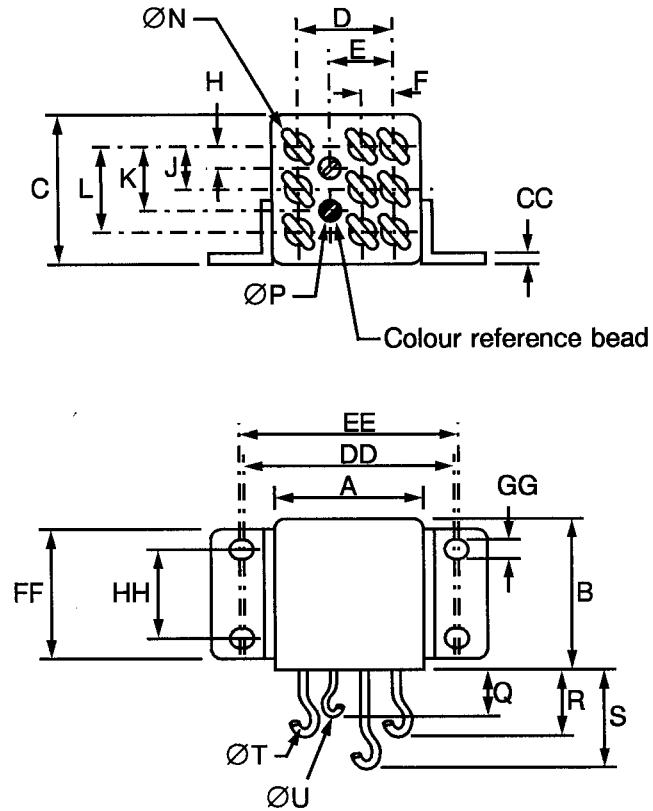

SYMBOL	MILLIMETRES	
	MIN.	MAX.
AA	-	43.60
BB	-	-
CC	0.90	1.10
DD	35.20	35.70
EE	36.45	36.95
FF	23.60	24.00
GG	3.55	4.05
HH	15.65	16.15
A	-	26.00
B	-	25.70
C	-	26.00

SYMBOL	MILLIMETRES	
	MIN.	MAX.
D	15.80	16.20
E	10.80	11.20
F	5.80	6.00
H	3.70	3.90
J	7.50	7.70
K	11.20	11.60
L	15.00	15.40
$\varnothing N$	2.30	2.45
$\varnothing P$	0.95	1.10
Q	7.10	8.10
R	9.00	10.00
S	15.40	16.40
$\varnothing T$	2.30	2.45
$\varnothing U$	0.95	1.10

FIGURE 2 - PHYSICAL DIMENSIONS (CONTINUED)

FIGURE 2(d) - VARIANT 05, RELAY WITH PLUG-IN TERMINALS AND PLAIN CASE

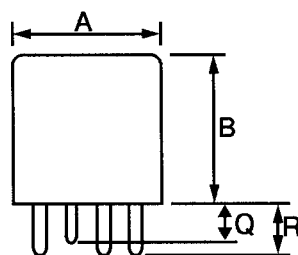
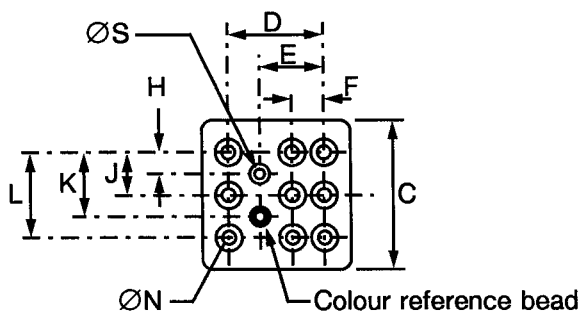

SYMBOL	MILLIMETRES	
	MIN.	MAX.
A	-	26.00
B	-	25.70
C	-	26.00
D	15.80	16.20
E	10.80	11.20
F	5.70	6.20
H	3.70	3.90
J	7.50	7.70
K	11.20	11.60
L	15.00	15.40
$\varnothing N$	2.30	2.41
Q	6.10	6.60
R	6.60	7.10
$\varnothing S$	1.55	1.61

FIGURE 2 - PHYSICAL DIMENSIONS (CONTINUED)

FIGURE 2(e) - VARIANT 06, RELAY WITH SOLDERABLE HOOK-END TERMINALS AND PLAIN CASE

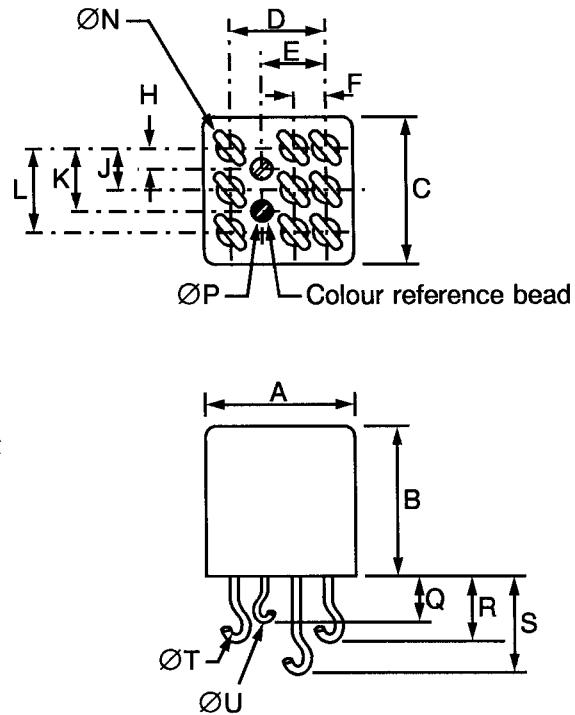

SYMBOL	MILLIMETRES	
	MIN.	MAX.
A	-	26.00
B	-	25.70
C	-	26.00
D	15.80	16.20
E	10.80	11.20
F	5.80	6.00
H	3.70	3.90
J	7.50	7.70
K	11.20	11.60
L	15.00	15.40
$\varnothing N$	2.30	2.45
$\varnothing P$	0.95	1.10
Q	7.10	8.10
R	9.00	10.00
S	15.40	16.40
$\varnothing T$	2.30	2.45
$\varnothing U$	0.95	1.10

FIGURE 3 - CIRCUIT SCHEMATIC

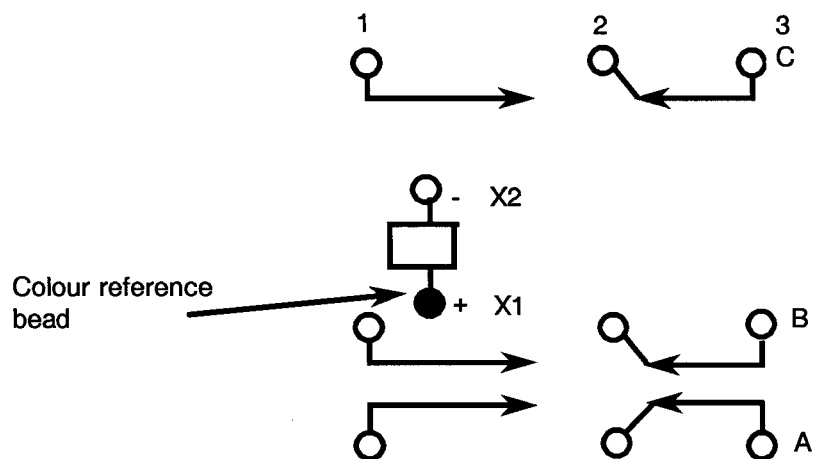

AS VIEWED FROM TERMINAL SIDE

NOTES

1. Numbers are for information only.



4. REQUIREMENTS

4.1 GENERAL

The complete requirements for procurement of the relays specified herein are stated in this specification and ESCC Generic Specification No. 3601 for Relays, Electromagnetic Non-latching. Deviations from the Generic Specification, applicable to this specification only, are listed in Para 4.2.

Deviations from the applicable Generic Specification and this Detail Specification, formally agreed with specific Manufacturers on the basis that the alternative requirements are equivalent to the ESCC requirements and do not affect the components' reliability, are listed in the appendices attached to this specification.

4.2 DEVIATIONS FROM GENERIC SPECIFICATION

4.2.1 Deviations from Special In-process Controls

None.

4.2.2 Deviations from Final Production Tests (Chart II)

None

4.2.3 Deviations from Screening Tests (Chart III)

(a) Para 9.6, Vibration Scan: Frequency Range: 10 - 3000Hz.

4.2.4 Deviations from Qualification Tests (Chart IV)

(a) Para 9.10, Vibration: Frequency Range: 10 - 3000 Hz.

(b) Para 9.11, Mechanical Shock: Test Condition: 200g, 6.0ms, 1/2 sinewave.

(c) Para 9.12, Overload: Separate tests shall be performed for N/O and N/C contacts.

4.2.5 Deviations from Lot Acceptance Tests (Chart V)

(a) Para 9.10, Vibration: Frequency Range: 10 - 3000 Hz.

(b) Para 9.11, Mechanical Shock: Test Condition: 200g, 6.0ms, 1/2 sinewave.

(c) Para 9.12, Overload: Separate tests shall be performed for N/O and N/C contacts.

4.3 MECHANICAL REQUIREMENTS

4.3.1 Dimension Check

The dimensions of the relays specified herein shall be verified in accordance with the requirements set out in Para 9.23 of ESCC Generic Specification No. 3601 and shall conform to those shown in Figure 2.

4.3.2 Weight

The maximum weight of the relays specified herein shall be 82 grammes.

4.3.3 Terminal Strength

The requirements for terminal strength testing are specified in Section 9 of ESCC Generic Specification No. 3601. The test conditions shall be as follows:-

Pull Test

Applied Force: 50 Newtons for terminal diameter greater than 1.2mm.
25 Newtons for terminal diameter equal to or smaller than 1.2mm.

4.4 MATERIALS AND FINISHES

The materials and finishes shall be as specified herein. Where a definite material is not specified, a material which will enable the relays specified herein to meet the performance requirements of this specification shall be used. Acceptance or approval of any constituent material does not guarantee acceptance of the finished product.

4.4.1 Case

Copper nickel, welded construction. Neither electro-deposited tin nor any paint shall be used.

4.4.2 Terminal Material and Finish

The terminal material shall be Type 'H' with Type '3 or 4' finish in accordance with the requirements of ESCC Basic Specification No. 23500.

4.5 MARKING

4.5.1 General

The marking of components delivered to this specification shall be in accordance with the requirements of ESCC Basic Specification No. 21700 and the following paragraphs. When the component is too small to accommodate all of the marking specified, as much as space permits shall be marked and the marking information, in full, shall accompany the component in its primary package.

The information to be marked and the order of precedence, shall be as follows:-

- (a) Terminal Identification.
- (b) The ESCC Component Number.
- (c) Electrical Characteristics.
- (d) Traceability Information.

4.5.2 Terminal Identification

Terminal identification shall be marked on the relay can in accordance with Figure 3.

4.5.3 The ESCC Component Number

Each component shall bear the ESCC Component Number which shall be constituted and marked as follows:

Detail Specification Number _____ 360100902B
Type Variant (see Table 1(a)) _____
Testing Level _____

4.5.4 Electrical Characteristics

The electrical characteristic to be marked is the rated coil voltage. The information shall be constituted and marked as follows:-

Coil Voltage	Coil Resistance	Code
28Vdc	290Ω	28V
12Vdc	70Ω	12V
6.0Vdc	18Ω	6V

4.5.5 Traceability Information

Each component shall be marked in respect of traceability information in accordance with the requirements of ESCC Basic Specification No. 21700.

4.6 ELECTRICAL MEASUREMENTS

4.6.1 Electrical Measurements at Room Temperature

The parameters to be measured at room temperature are scheduled in Table 2. Unless otherwise specified, the measurements shall be performed at $T_{amb} = +22 \pm 3$ °C.

4.6.2 Electrical Measurements at High and Low Temperatures

The parameters to be measured at high and low temperatures are scheduled in Table 3.

4.6.3 Circuits for Electrical Measurements (Figure 4)

Not applicable.

4.7 SCREENING

4.7.1 Miss Test

During the miss test, the contact resistance shall be continuously monitored and shall not exceed the values specified in Table 4 of this specification.

4.7.2 Conditions for Screening

The requirements for screening are specified in Section 7 of ESCC Generic Specification No. 3601. The conditions for screening shall be as specified in Table 5(a) of this specification.

4.7.3 Electrical Circuits for Screening (Figure 5(a))

Not applicable.

TABLE 2 - ELECTRICAL MEASUREMENTS AT ROOM TEMPERATURE

No.	CHARACTERISTICS	SYMBOL	ESCC 3601 TEST METHOD	TEST CONDITION	LIMITS		UNIT
					MIN.	MAX.	
1	Pick-up Voltage:- 28V 12V 6V	U_C	Para. 9.3.1	Para. 9.3.1	- - -	13.5 6.5 3.2	V
2	Drop-out Voltage:- 28V 12V 6V	U_d	Para. 9.3.2	Para. 9.3.2	2.3 0.75 0.4	5.5 3.3 1.6	V
3	Operate Time	t_c	Para. 9.3.4	Para. 9.3.4	-	15	ms
4	Release Time	t_d	Para. 9.3.4	Para. 9.3.4	-	15	ms
5	Bounce Time	t_b	Para. 9.3.4	Para. 9.3.4	-	1.0	ms
6	Insulation Resistance	R_i	Para. 9.3.7	Para. 9.3.7 At 500Vdc	100	-	M Ω
7	Voltage Proof	VP	Para. 9.3.6	Para. 9.3.6 Note 1	1250	-	Vrms
8	Contact Voltage Drop	V_d	Para. 9.3.3	Para. 9.3.3 d.c. Method	-	150	mV
9	Coil Resistance:- 28V 12V 6V	R_B	Para. 9.3.5	Para. 9.3.5	260 63 16	320 77 20	Ω

NOTES

1. 1000V between coil and case, between open contacts.

TABLE 3 - ELECTRICAL MEASUREMENTS AT HIGH AND LOW TEMPERATURES

No.	CHARACTERISTICS	SYMBOL	ESCC 3601 TEST METHOD	TEST CONDITION	LIMITS		UNIT
					MIN.	MAX.	
1	Pick-up Voltage:- 28V 12V 6V	U_C	Para. 9.3.1	Para. 9.3.1	- - -	19.8 9.0 4.5	V
2	Drop-out Voltage:- 28V 12V 6V	U_d	Para. 9.3.2	Para. 9.3.2	1.5 0.5 0.25	7.0 4.5 2.3	V
3	Operate Time	t_C	Para. 9.3.4	Para. 9.3.4	-	15	ms
4	Release Time	t_d	Para. 9.3.4	Para. 9.3.4	-	15	ms
5	Bounce Time	t_b	Para. 9.3.4	Para. 9.3.4	-	1.0	ms
6	Insulation Resistance (Note 1)	R_i	Para. 9.3.7	Para. 9.3.7 at 500Vdc Note 1	50	-	M Ω

NOTES

1. This measurement shall be made only at the high temperature condition.

FIGURE 4 - CIRCUITS FOR ELECTRICAL MEASUREMENTS

Not applicable.

TABLE 4 - MEASUREMENTS DURING SCREENING

No.	CHARACTERISTICS	SYMBOL	ESCC 3601 TEST METHOD	TEST CONDITIONS	MAXIMUM LIMIT	UNIT
10	Miss Test, Contact Resistance	R_C	Para. 9.8	Para. 9.8	100	Ω

TABLE 5(a) - CONDITIONS FOR SCREENING

No.	CHARACTERISTICS	SYMBOL	CONDITION	UNIT
1	Ambient High Temperature	T_{amb}	+ 125(+ 0 - 3)	$^{\circ}C$
2	Ambient Low Temperature	T_{amb}	- 65(+ 3 - 0)	$^{\circ}C$
3	Ambient Room Temperature	T_{amb}	+ 22 \pm 3	$^{\circ}C$

TABLE 5(b) - CONDITIONS FOR OPERATING LIFE TEST

No.	CHARACTERISTICS	SYMBOL	CONDITION	UNIT
1	Ambient Temperature	T_{amb}	+ 125(+ 0 - 3)	$^{\circ}C$
2	Contact Load Resistive	V I	28 25	Vdc Adc

FIGURE 5(a) - ELECTRICAL CIRCUITS FOR SCREENING

Not applicable.

FIGURE 5(b) - ELECTRICAL CIRCUITS FOR OPERATING LIFE TESTS

Not applicable.

- 4.8 ENVIRONMENTAL AND ENDURANCE TESTS (CHARTS IV AND V OF ESCC GENERIC SPECIFICATION No. 3601)
- 4.8.1 Measurements and Inspections on Completion of Environmental Tests
The parameters to be measured and inspections to be performed on completion of environmental tests are scheduled in Table 6. Unless otherwise stated, the measurements shall be performed at $T_{amb} = +22 \pm 3 \text{ }^{\circ}\text{C}$.
- 4.8.2 Measurements and Inspections during Endurance Tests
The parameters to be measured and inspections to be performed during endurance tests are scheduled in Table 6. Unless otherwise stated, the measurements shall be performed at $T_{amb} = +22 \pm 3 \text{ }^{\circ}\text{C}$.
- 4.8.3 Measurements and Inspections on Completion of Endurance Tests
The parameters to be measured and inspections to be performed on completion of endurance tests are scheduled in Table 6. Unless otherwise stated, the measurements shall be performed at $T_{amb} = +22 \pm 3 \text{ }^{\circ}\text{C}$.
- 4.8.4 Conditions for Operating Life Tests (Part of Endurance Testing)
The requirements for operating life testing are specified in Section 9 of ESCC Generic Specification No. 3601. The conditions for operating life testing shall be as specified in Table 5(b) of this specification.
- 4.8.5 Electrical Circuits for Operating Life Tests (Figure 5(b))
Not applicable.

TABLE 6 - MEASUREMENTS AND INSPECTIONS ON COMPLETION OF ENVIRONMENTAL TESTS AND AT INTERMEDIATE POINTS AND ON COMPLETION OF ENDURANCE TESTING

No.	ESCC GENERIC SPEC. NO. 3601		MEASUREMENTS AND INSPECTIONS		SYMBOL	LIMITS		UNIT
	ENVIRONMENTAL AND ENDURANCE TESTS (1)	TEST METHOD AND CONDITIONS	IDENTIFICATION	CONDITIONS		MIN.	MAX.	
01	Vibration	Para. 9.10 and Para. 4.2.4 of this spec.	Measurements during Test Contact Monitoring Final Measurements Visual Examination	ESCC 3601 Para. 9.10 -	- -	- -	- -	- -
02	Mechanical Shock	Para. 9.11 and Para. 4.2.4 of this spec.	Measurements during Test Contact Monitoring Final Measurements Electrical Measurements Visual Examination	ESCC 3601 Para. 9.11 Table 2 Items 7-8-1-2 -	- -	- Table 2 -	- -	- -
03	Overload	Para. 9.12 and Table 1(b) Item 4 and Para. 4.2.4 of this spec.	Measurements during Test Contact Voltage Drop Final Measurements Fuse Continuity Contact Voltage Drop Insulation Resistance Voltage Proof (all Points) Electrical Measurements	ESCC 3601 Para. 9.12.3 - Table 2 Item 8 Table 2 Item 6 Table 2 Item 7 Table 2 Items 1-2-3-4-5-9	V _d - V _d R _i VP	Para. 9.12.3 Continuity - 175 50 - 1000 - Table 2	mV mV MΩ Vrms	
04	Thermal Shock	Para. 9.13	During 5th Cycle Electrical Measurements at +125°C Electrical Measurements at -65°C Final Measurements Visual Examination Voltage Proof (all Points)	In Conditioning Chamber Table 3 Items 1-2-3-4-7 Table 3 Items 1-2-3-4 - Table 2 Item 7	- - VP	Table 3 Table 3 - Table 2	- -	- Vrms
05	Salt Spray	Para. 9.14	Final Measurements Visual Examination Electrical Measurements Voltage Proof (all Points)	- Table 2 Items 1-2-3-4-5-6-8-9 Table 2 Item 7	- - VP	- Table 2 1000 -	- -	- Vrms
06	Intermediate Current	Para. 9.16	Measurements during Test Contact Voltage Drop Final Measurements Insulation Resistance Voltage Proof (all Points) Electrical Measurements Contact Voltage Drop (2)	ESCC 3601 Para. 9.16.3 Table 2 Item 6 Table 2 Item 7 Table 2 Items 1-2-3-4-5-9 ESCC 3601 Para. 9.16.3	V _d - R _i VP V _d	Para. 9.16.3 50 - 1000 - Table 2 Para. 9.16.3	mV MΩ Vrms mV	
07	Terminal Strength	Para. 9.17 and Para. 4.3.3 of this spec.	Visual Examination	ESCC 3601 Para. 9.17.3	-	-	-	-

NOTES

1. The tests in this table refer to either Chart IV or V and shall be used as applicable.
2. Reading time 5 to 10 seconds, if required.



TABLE 6 - MEASUREMENTS AND INSPECTIONS ON COMPLETION OF ENVIRONMENTAL TESTS AND AT INTERMEDIATE POINTS AND ON COMPLETION OF ENDURANCE TESTING (CONT'D)

No.	ESCC GENERIC SPEC. NO. 3601		MEASUREMENTS AND INSPECTIONS		SYMBOL	LIMITS		UNIT
	ENVIRONMENTAL AND ENDURANCE TESTS (1)	TEST METHOD AND CONDITIONS	IDENTIFICATION	CONDITIONS		MIN.	MAX.	
08	Resistance to Soldering Heat	Para. 9.18	Electrical Measurements	Table 2 Items 1-2-6-8-9		Table 2		
09	Operating Life Resistive	Para's 9.19, 9.19.1 and Table 5(b) of this spec.	Measurements during Test Contact Voltage Drop Final Measurements Fuse Continuity Contact Voltage Drop (2) Insulation Resistance Voltage Proof (all Points) Electrical Measurements	ESCC 3601 Para. 9.19.1 - Table 2 Item 8 Table 2 Item 6 Table 2 Item 7 Table 2 Items 1-2-3-4-5-9	V_d - V_d R_i VP	Para. 9.19.1 Continuity - 175 50 - 1000 - Table 2	mV mV MΩ Vrms	
10	Inductive Life	Para. 9.19.3 and Table 1(b) Item 5 of this spec.	Measurements during Test Contact Voltage Drop Final Measurements Fuse Continuity Contact Voltage Drop Insulation Resistance Voltage Proof (all Points) Electrical Measurements	ESCC 3601 Para. 9.19.1 - Table 2 Item 8 Table 2 Item 6 Table 2 Item 7 Table 2 Items 1-2-3-4-5-9	V_d - V_d R_i VP	Para. 9.19.1 Continuity - 175 50 - 1000 - Table 2	mV mV MΩ Vrms	
11	Mechanical Life	Para. 9.19.4	Final Measurements Contact Voltage Drop Electrical Measurements	Table 2 Item 8 Table 2 Items 1-2-3-4-5-9		- 175 Table 2	mV	
12	Coil Life	Para. 9.20	Initial Measurements Electrical Measurements After 100 hours Electrical Measurements at -65°C At 250, 500, 750 hours Electrical Measurements During Last Cycle Electrical Measurements at +125°C Electrical Measurements at -65°C Final Measurements Electrical Measurements Visual Examination	Table 2 Items 8-9 Table 2 Item 8 Table 3 Items 3-4 Table 2 Items 8-9 Table 3 Items 1-2 Table 3 Items 1-2 Table 2 Items 3 to 9 -		Table 2 Table 2 Table 3 Table 2 Table 3 Table 3 Table 3 Table 2 -	- - - - - -	

NOTES

1. The tests in this table refer to either Chart IV or V and shall be used as applicable.
2. Reading time 5 to 10 seconds, if required.