



Pages 1 to 22

**RELAYS, ELECTROMAGNETIC, LATCHING,
28Vdc, 15A, 4PDT,
ESCC Detail Specification No. 3602/004**

**ISSUE 2
September 2004**



Document Custodian: European Space Agency - see <https://escies.org>

	ESCC Detail Specification No. 3602/004		PAGE i ISSUE 2
--	---	--	-------------------

LEGAL DISCLAIMER AND COPYRIGHT

European Space Agency, Copyright © 2004. All rights reserved.

The European Space Agency disclaims any liability or responsibility, to any person or entity, with respect to any loss or damage caused, or alleged to be caused, directly or indirectly by the use and application of this ESCC publication.

This publication, without the prior permission of the European Space Agency and provided that it is not used for a commercial purpose, may be:

- copied in whole in any medium without alteration or modification.
- copied in part, in any medium, provided that the ESCC document identification, comprising the ESCC symbol, document number and document issue, is removed.

	<p style="text-align: center;">ESCC Detail Specification No. 3602/004</p>		<p>PAGE 2 ISSUE 2</p>
---	---	--	---------------------------

DOCUMENTATION CHANGE NOTICE

(Refer to <https://escies.org> for ESCC DCR content)

DCR No.	CHANGE DESCRIPTION
130	Specification upissued to incorporate technical and editorial changes per DCR.



TABLE OF CONTENTS

	<u>Page</u>
1. <u>GENERAL</u>	5
1.1 Scope	5
1.2 Component Type Variants	5
1.3 Maximum Ratings	5
1.4 Parameter Derating Information	5
1.5 Physical Dimensions	5
1.6 Circuit Schematic	5
2. <u>APPLICABLE DOCUMENTS</u>	5
3. <u>TERMS, DEFINITIONS, ABBREVIATIONS, SYMBOLS AND UNITS</u>	5
4. <u>REQUIREMENTS</u>	14
4.1 General	14
4.2 Deviations from Generic Specification	14
4.2.1 Deviations from Special In-Process Controls	14
4.2.2 Deviations from Final Production Tests	14
4.2.3 Deviations from Screening Tests	14
4.2.4 Deviations from Qualification Tests	14
4.2.5 Deviations from Lot Acceptance Tests	14
4.3 Mechanical Requirements	15
4.3.1 Dimension Check	15
4.3.2 Weight	15
4.3.3 Terminal Strength	15
4.4 Materials and Finishes	15
4.4.1 Case	15
4.4.2 Terminal Material and Finish	15
4.5 Marking	15
4.5.1 General	15
4.5.2 Terminal Identification	15
4.5.3 The ESCC Component Number	16
4.5.4 Electrical Characteristics	16
4.5.5 Traceability Information	16
4.6 Electrical Measurements	16
4.6.1 Electrical Measurements at Room Temperature	16
4.6.2 Electrical Measurements at High and Low Temperatures	16
4.6.3 Circuits for Electrical Measurements	16
4.7 Screening	16
4.7.1 Miss Test	16
4.7.2 Conditions for Screening	16
4.7.3 Electrical Circuits for Screening	16
4.8 Environmental and Endurance Testing	20
4.8.1 Measurements and Inspections on Completion of Environmental Tests	20
4.8.2 Measurements and Inspections during Endurance Tests	20
4.8.3 Measurements and Inspections on Completion of Endurance Tests	20
4.8.4 Conditions for Operating Life Tests	20
4.8.5 Electrical Circuits for Operating Life Tests	20

	<p style="text-align: center;">ESCC Detail Specification No. 3602/004</p>		<p>PAGE 4 ISSUE 2</p>
--	---	--	---------------------------

<u>TABLES</u>		<u>Page</u>
1(a)	Type Variants	6
1(b)	Maximum Ratings	6
2	Electrical Measurements at Room Temperature	17
3	Electrical Measurements at High and Low Temperatures	18
4	Measurements during Screening	19
5(a)	Conditions for Screening	19
5(b)	Conditions for Operating Life Test	19
6	Measurements and Inspection on Completion of Environmental Tests and at Intermediate Points and on Completion of Endurance Testing	21

<u>FIGURES</u>		
1	Not applicable	N/A
2	Physical Dimensions	7
3	Circuit Schematic	13
4	Circuits for Electrical Measurements	19
5(a)	Electrical Circuits for Screening	19
5(b)	Electrical Circuits for Operating Life Test	19

APPENDICES (Applicable to specific Manufacturers only)
None.



1. **GENERAL**

1.1 **SCOPE**

This specification details the ratings, physical and electrical characteristics, test and inspection data for a Relay, Electromagnetic, Latching, 28Vdc, 15A, 4PDT. It shall be read in conjunction with ESCC Generic Specification No. 3602, the requirements of which are supplemented herein.

1.2 **COMPONENT TYPE VARIANTS**

Variants of the basic type relays specified herein, which are also covered by this specification, are given in Table 1(a).

1.3 **MAXIMUM RATINGS**

The maximum ratings, which shall not be exceeded at any time during use or storage, applicable to the relays specified herein, are scheduled in Table 1(b).

1.4 **PARAMETER DERATING INFORMATION (FIGURE 1)**

Not applicable.

1.5 **PHYSICAL DIMENSIONS**

The physical dimensions of the relays specified herein are shown in Figure 2.

1.6 **CIRCUIT SCHEMATIC**

The circuit schematic, showing lead identification etc. for the relays specified herein, is shown in Figure 3.

2. **APPLICABLE DOCUMENTS**

The following documents form part of this specification and shall be read in conjunction with it:-

- (a) ESCC Generic Specification No. 3602 for Relays, Electromagnetic, Latching.
- (b) MIL-STD-202, Test Methods for Electronic and Electrical Component Parts.

3. **TERMS, DEFINITIONS, ABBREVIATIONS, SYMBOLS AND UNITS**

For the purpose of this specification, the terms, definitions, abbreviations, symbols and units specified in ESCC Basic Specification No. 21300 shall apply.

TABLE 1(a) - TYPE VARIANTS

VARIANT (Note 1)	DESCRIPTION	
01, 11	Straight terminals and plain case	2(a)
02, 12	As variant 01, 11 + polarising pin	2(a)
03, 13	Hook terminals and plain case	2(b)
04, 14	Straight terminals and horizontal flange mount	2(c)
05, 15	As variant 04, 14 + polarising pin	2(c)
06, 16	Hook terminals and horizontal flange mount	2(d)
07, 17	Straight terminals and vertical flange mount	2(e)
08, 18	As variant 07, 17 + polarising pin	2(e)
09, 19	Hook terminals and vertical flange mount	2(f)

NOTES

1. Variant differences are coil resistance (see Table 2 item 9).

TABLE 1(b) - MAXIMUM RATINGS

No.	CHARACTERISTICS	SYMBOL	MAXIMUM RATING	UNIT	REMARKS
1	Rated Coil Voltage:- 28V 12V 6V	V_C	28 12 6.0	Vdc	Note 3
2	Maximum Rated Coil Voltage:- 28V 12V 6V	V_{Cmax}	26.5 to 32 11 to 14.5 5.5 to 7.3	Vdc	
3	Rated Contact Current Resistive Load	I_{CR}	15	A	28Vdc resistive Note 1
4	Overload Current Resistive	I_{overL}	40	A	28Vdc resistive See Table 6
5	Rated Contact Current Inductive Load	I_{CL}	8.0	A	28Vdc inductive Note 1
6	Contact Resistance	R_C	10	m Ω	At rated current
7	High Temperature	T_{amb}	+ 125	$^{\circ}C$	
8	Low Temperature	T_{amb}	- 65	$^{\circ}C$	
9	Soldering Temperature	T_{sol}	+ 260	$^{\circ}C$	Note 2

NOTES

1. Relays should not be used in change over-mode where the potential difference between stationary contacts is greater than 10V and the switched current is greater than 0.1A.
2. Duration 10 seconds maximum at a distance of not less than 3.0mm from the device body and the same terminal shall not be resoldered until 3 minutes have elapsed.
3. The Coil Voltage rise time shall be less than $0.1t_L$ or t_r . The coil voltage shall be applied for a minimum time of $10t_L$ or $10t_r$.

FIGURE 2 - PHYSICAL DIMENSIONS

**FIGURE 2(a) -
VARIANTS 01 AND 11, RELAY WITH STRAIGHT TERMINALS AND PLAIN CASE
VARIANT 02, IDENTICAL TO VARIANT 01 + POLARISING PIN
VARIANT 12, IDENTICAL TO VARIANT 11 + POLARISING PIN**

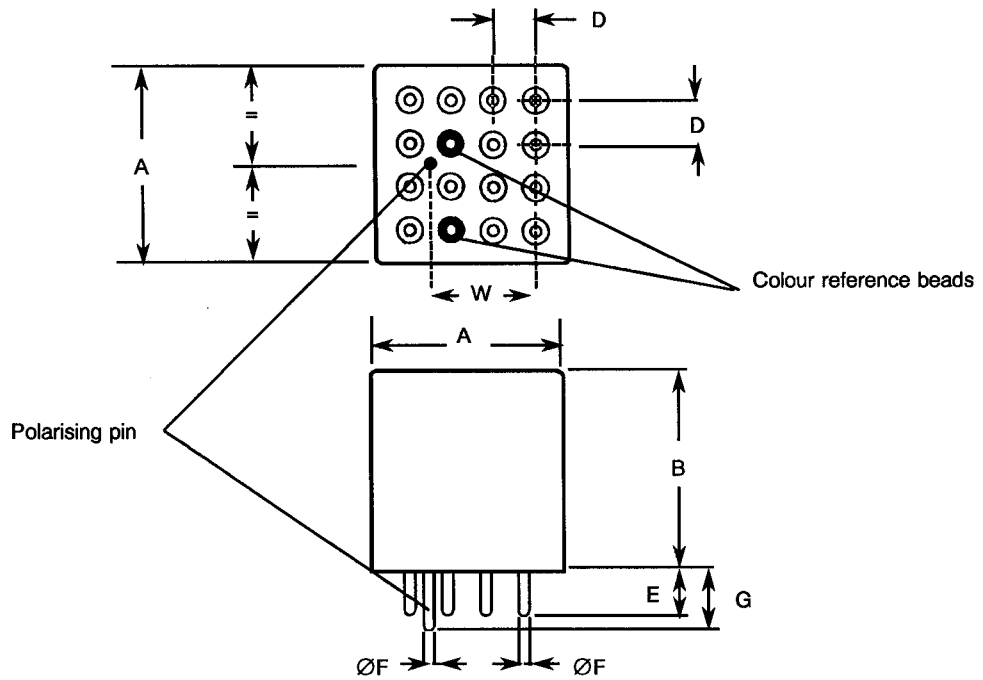

SYMBOL	MILLIMETRES	
	MIN.	MAX.
A	-	26.00
B	-	25.70
D	4.98	5.18
E	6.70	7.10
ØF	1.55	1.62
G	7.40	8.00
W	12.50	12.90

NOTES

1. Symbols G and W are for Variants 02 and 12 only.

FIGURE 2 - PHYSICAL DIMENSIONS (CONTINUED)

**FIGURE 2(b) -
VARIANTS 03 AND 13, RELAY WITH HOOK TERMINALS AND PLAIN CASE**

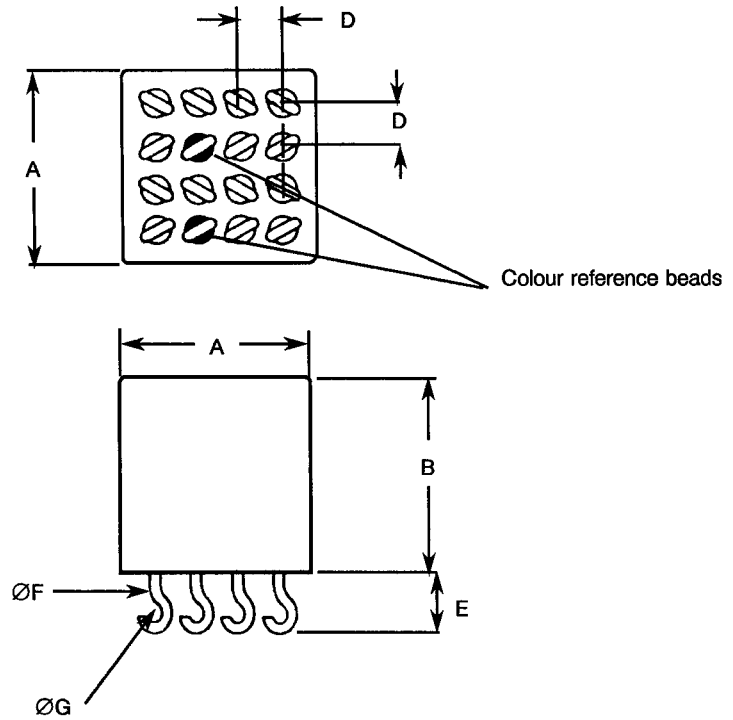

SYMBOL	MILLIMETRES	
	MIN.	MAX.
A	-	26.00
B	-	25.70
D	4.80	5.20
E	-	8.00
ØF	1.52	1.63
ØG	1.75	2.25

FIGURE 2 - PHYSICAL DIMENSIONS (CONTINUED)

**FIGURE 2(c) -
VARIANTS 04 AND 14, RELAY WITH STRAIGHT TERMINALS AND HORIZONTAL FLANGE MOUNT
VARIANT 05, IDENTICAL TO VARIANT 04 + POLARISING PIN
VARIANT 15, IDENTICAL TO VARIANT 14 + POLARISING PIN**

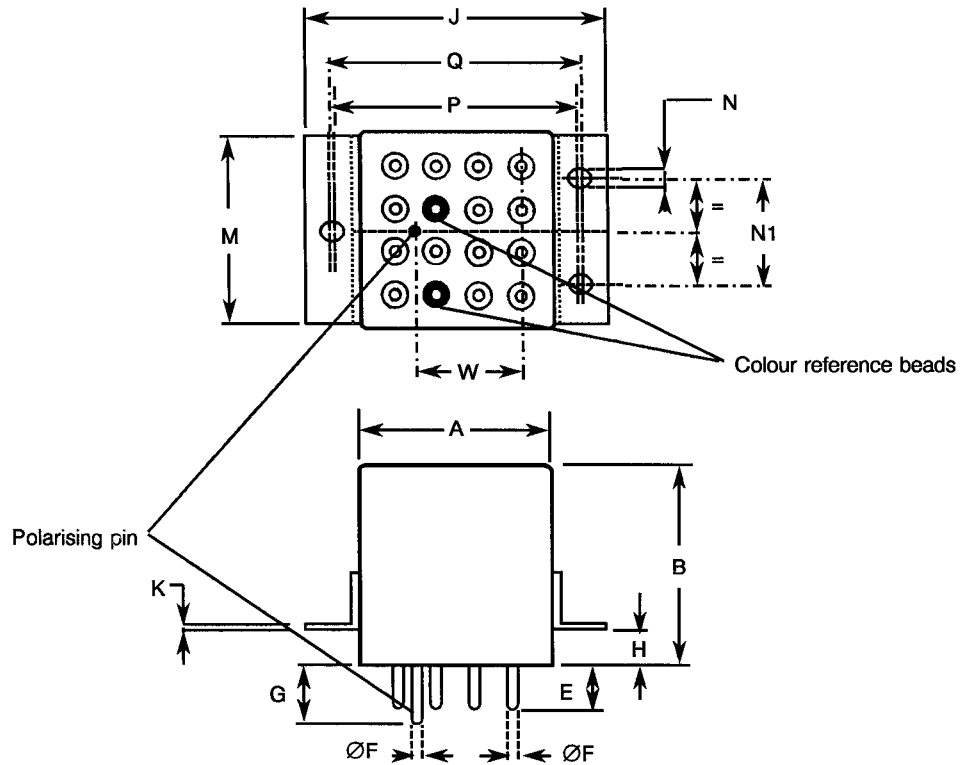

SYMBOL	MILLIMETRES	
	MIN.	MAX.
A	-	26.00
B	-	25.70
E	6.70	7.10
ØF	1.55	1.62
G	7.40	8.00
H	3.80	4.20
J	-	43.60
K	0.90	1.10
M	23.60	24.00
N	3.70	3.90
N1	15.65	16.15
P	35.20	35.70
Q	36.45	36.95
W	12.50	12.90

NOTES

1. Symbols G and W are for Variants 05 and 15 only.

FIGURE 2 - PHYSICAL DIMENSIONS (CONTINUED)

FIGURE 2(d) - VARIANTS 06 AND 16, RELAY WITH HOOK TERMINALS AND HORIZONTAL FLANGE MOUNT

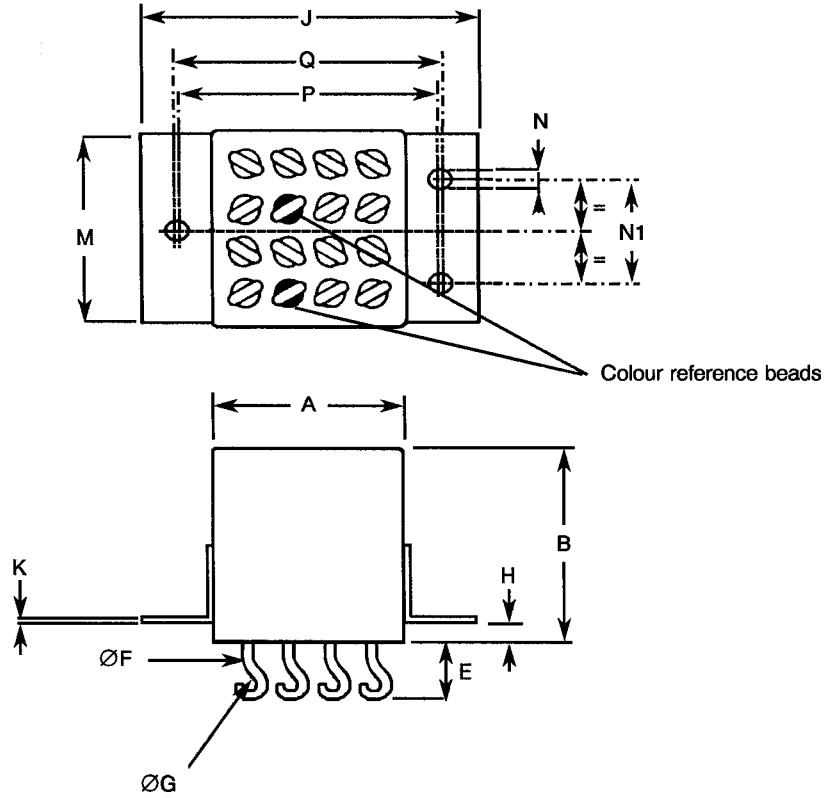

SYMBOL	MILLIMETRES	
	MIN.	MAX.
A	-	26.00
B	-	25.70
E	-	8.00
ØF	1.52	1.63
ØG	1.75	2.25
H	3.80	4.20
J	-	43.60
K	0.90	1.10
M	23.60	24.00
N	3.70	3.90
N1	15.65	16.15
P	35.20	35.70
Q	36.45	36.95

FIGURE 2 - PHYSICAL DIMENSIONS (CONTINUED)

**FIGURE 2(e) -
VARIANTS 07 AND 17, RELAY WITH STRAIGHT TERMINALS AND VERTICAL FLANGE MOUNT
VARIANT 08, IDENTICAL TO VARIANT 07 + POLARISING PIN
VARIANT 18, IDENTICAL TO VARIANT 17 + POLARISING PIN**

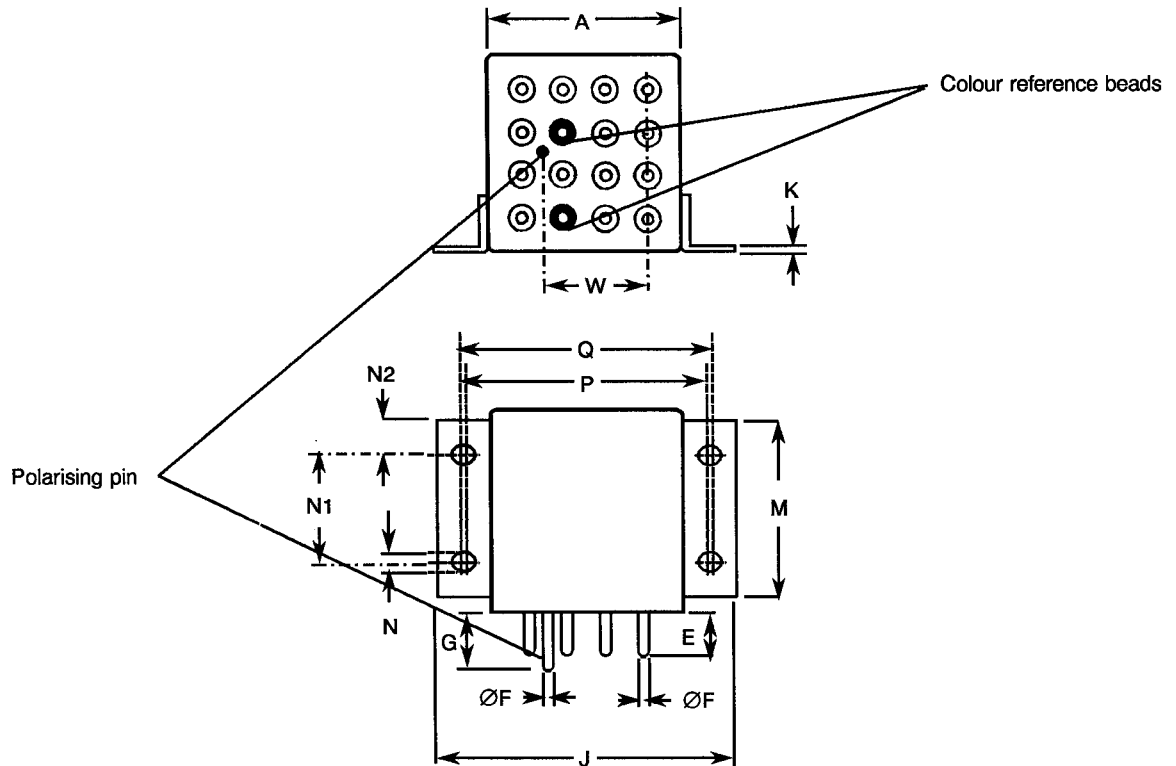

SYMBOL	MILLIMETRES	
	MIN.	MAX.
A	-	26.00
E	6.70	7.10
ØF	1.55	1.62
G	7.40	8.00
J	-	43.60
K	0.90	1.10
M	23.60	24.00
N	3.70	3.90
N1	15.65	16.15
N2	3.90	4.10
P	35.20	35.70
Q	36.45	36.95
W	12.50	12.90

NOTES

1. Symbols G and W are for Variants 08 and 18 only.

FIGURE 2 - PHYSICAL DIMENSIONS (CONTINUED)

FIGURE 2(f) - VARIANTS 09 AND 19, RELAY WITH HOOK TERMINALS AND VERTICAL FLANGE MOUNT

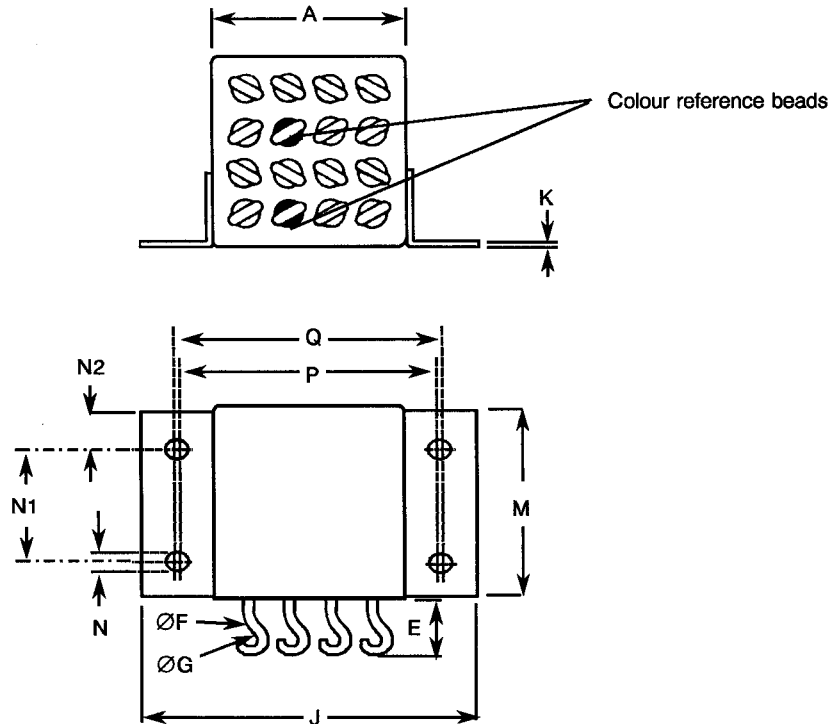

SYMBOL	MILLIMETRES	
	MIN.	MAX.
A	-	26.00
E	-	8.00
ØF	1.52	1.63
ØG	1.75	2.25
J	-	43.60
K	0.90	1.10
M	23.60	24.00
N	3.70	3.90
N1	15.65	16.15
N2	3.90	4.10
P	35.20	35.70
Q	36.45	36.95

FIGURE 3 - CIRCUIT SCHEMATIC

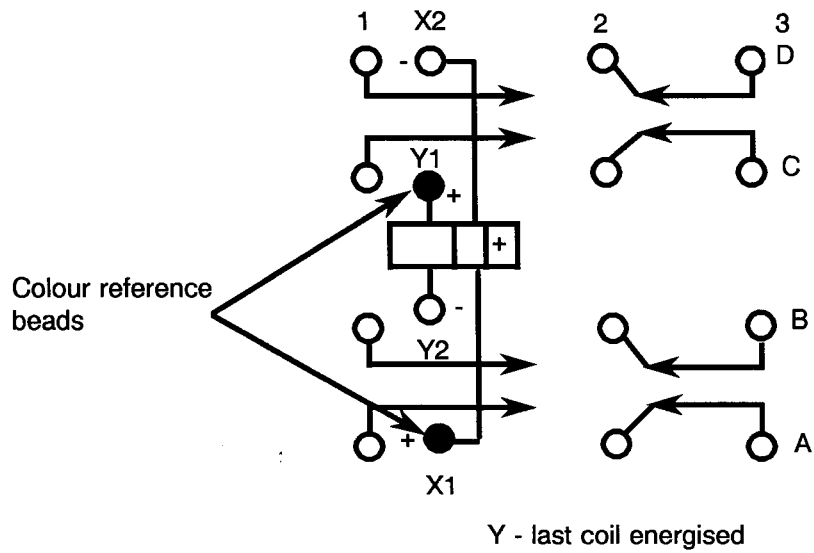

As viewed from terminal side

NOTES

1. Number appears for reference purposes only.



4. REQUIREMENTS

4.1 GENERAL

The complete requirements for procurement of the relays specified herein shall be as stated in this specification and ESCC Generic Specification No. 3602 for Relays, Electromagnetic Latching. Deviations from the Generic Specification, applicable to this specification only, are listed in Para 4.2.

Deviations from the applicable Generic Specification and this Detail Specification, formally agreed with specific Manufacturers on the basis that the alternative requirements are equivalent to the ESCC requirements and do not affect the components' reliability, are listed in the appendices attached to this specification.

4.2 DEVIATIONS FROM GENERIC SPECIFICATION

4.2.1 Deviations from Special In-process Controls

None.

4.2.2 Deviations from Final Production Tests (Chart II)

(a) Para 9.4, Seal Test: 9.4.2(b): 1 hour 40 minutes minimum at 4 bars. 9.4.2(c): 30 minutes maximum.

4.2.3 Deviations from Screening Tests (Chart III)

(a) Para 9.4, Seal Test: 9.4.2(b): 1 hour 40 minutes minimum at 4 bars. 9.4.2(c): 30 minutes maximum.

(b) Para 9.6, Vibration Scan: Frequency range: 10 - 3000Hz.

4.2.4 Deviations from Qualification Tests (Chart IV)

(a) Para 9.4, Seal Test: 9.4.2(b): 1 hour 40 minutes minimum at 4 bars. 9.4.2(c): 30 minutes maximum.

(b) Para 9.10, Vibration: Frequency Range: 10 - 3000 Hz.

(c) Para 9.11, Mechanical Shock: Test Condition 'C'.

(d) Para 9.12, Overload: Separate tests shall be performed for N/O and N/C contacts. Overload current shall be 40A resistive.

4.2.5 Deviations from Lot Acceptance Tests (Chart V)

(a) Para 9.4, Seal Test: 9.4.2(b): 1 hour 40 minutes minimum at 4 bars. 9.4.2(c): 30 minutes maximum.

(b) Para 9.10, Vibration: Frequency Range: 10 - 3000 Hz.

(c) Para 9.11, Mechanical Shock: Test Condition 'C'.

(d) Para 9.12, Overload: Separate tests shall be performed for N/O and N/C contacts. Overload current shall be 40A resistive.

(e) Para. 9.16, Intermediate Current: The number of operations shall be 5000.

4.3 MECHANICAL REQUIREMENTS

4.3.1 Dimension Check

The dimensions of the relays specified herein shall be verified in accordance with the requirements set out in Para 9.5 of ESCC Generic Specification No. 3602 and shall conform to those shown in Figure 2.

4.3.2 Weight

The maximum weight of the relays specified herein shall be 80 grammes.

4.3.3 Terminal Strength

The requirements for terminal strength testing are specified in Section 9 of ESCC Generic Specification No. 3602. The test conditions shall be as follows:-

Pull Test

Applied Force: 50 Newtons.

4.4 MATERIALS AND FINISHES

The materials and finishes shall be as specified herein. Where a definite material is not specified, a material which will enable the relays specified herein to meet the performance requirements of this specification shall be used. Acceptance or approval of any constituent material does not guarantee acceptance of the finished product.

4.4.1 Case

Copper nickel, welded construction, Sn/Pb plated. Neither electro-deposited tin nor any paint shall be used.

4.4.2 Terminal Material and Finish

The terminal material shall be Type 'H' with Type '3 or 4' finish in accordance with the requirements of ESCC Basic Specification No. 23500.

4.5 MARKING

4.5.1 General

The marking of all components delivered to this specification shall be in accordance with the requirements of ESCC Basic Specification No. 21700 and the following paragraphs. When the component is too small to accommodate all of the marking specified, as much as space permits shall be marked and the marking information, in full, shall accompany the component in its primary package.

The information to be marked and the order of precedence, shall be as follows:-

- (a) Terminal Identification.
- (b) The ESCC Component Number.
- (c) Electrical Characteristic.
- (d) Traceability Information.

4.5.2 Terminal Identification

Terminal identification shall be marked on the relay can in accordance with Figure 3.

4.5.3 The ESCC Component Number

Each component shall bear the ESCC Component Number which shall be constituted and marked as follows:

Detail Specification Number _____ **360200402B**
 Type Variant (see Table 1(a)) _____
 Testing Level _____

4.5.4 Electrical Characteristics

The electrical characteristic to be marked is the rated coil voltage. The information shall be constituted and marked as follows:-

Coil Voltage	Coil Resistance		Code
	Variants 01 to 09	Variants 11 to 19	
28Vdc	300Ω	450Ω	28V
12Vdc	60Ω	111.5Ω	12V
6.0Vdc	15Ω	28Ω	6V

4.5.5 Traceability Information

Each component shall be marked in respect of traceability information in accordance with the requirements of ESCC Basic Specification No. 21700.

4.6 ELECTRICAL MEASUREMENTS

4.6.1 Electrical Measurements at Room Temperature

The parameters to be measured at room temperature are scheduled in Table 2. Unless otherwise specified, the measurements shall be performed at $T_{amb} = +22 \pm 3$ °C.

4.6.2 Electrical Measurements at High and Low Temperatures

The parameters to be measured at high and low temperatures are scheduled in Table 3.

4.6.3 Circuits for Electrical Measurements (Figure 4)

Not applicable.

4.7 SCREENING

4.7.1 Miss Test

During the miss test, the contact resistance shall be continuously monitored and shall not exceed the values specified in Table 4 of this specification.

4.7.2 Conditions for Screening

The requirements for screening are specified in Section 7 of ESCC Generic Specification No. 3602. The conditions for screening shall be as specified in Table 5(a) of this specification.

4.7.3 Electrical Circuits for Screening (Figure 5(a))

Not applicable.

TABLE 2 - ELECTRICAL MEASUREMENTS AT ROOM TEMPERATURE

No.	CHARACTERISTICS	SYMBOL	ESCC 3602 TEST METHOD	TEST CONDITION	LIMITS		UNIT
					MIN.	MAX.	
1	Latch Voltage:- 28V 12V 6V	U_L	Para. 9.3.1	Para. 9.3.1	9.1 3.6 1.8	14 6.6 3.3	V
2	Reset Voltage:- 28V 12V 6V	U_R	Para. 9.3.2	Para. 9.3.2	9.1 3.6 1.8	14 6.6 3.3	V
3	Latch Time	t_L	Para. 9.3.4	Para. 9.3.4	-	15	ms
4	Reset Time	t_r	Para. 9.3.4	Para. 9.3.4	-	15	ms
5	Bounce Time	t_b	Para. 9.3.4	Para. 9.3.4	-	1.0	ms
6	Insulation Resistance	R_i	Para. 9.3.7	Para. 9.3.7 at 500Vdc	100	-	M Ω
7	Voltage Proof	VP	Para. 9.3.6	Para. 9.3.6 Note 1	1250	-	Vrms
8	Contact Voltage Drop	V_d	Para. 9.3.3	Para. 9.3.3 15A - 6.0Vdc	-	150	mV
9	Coil Resistance Latch and Reset Variants 01 to 09:- 28V 12V 6V Variants 11 to 19:- 28V 12V 6V	R_B	Para .9.3.5	Para .9.3.5	270 54 13.5 405 100 25	330 66 16.5 495 123 31	Ω

NOTES

1. 1000V between coil and case, between open contacts; 350V between coils.



TABLE 3 - ELECTRICAL MEASUREMENTS AT HIGH AND LOW TEMPERATURES

No.	CHARACTERISTICS	SYMBOL	ESCC 3602 TEST METHOD	TEST CONDITION	LIMITS		UNIT
					MIN.	MAX.	
1	Latch Voltage:- 28V 12V 6V	U_L	Para. 9.3.1	Para. 9.3.1	6.3 2.5 1.3	19.8 9.0 4.5	V
2	Reset Voltage:- 28V 12V 6V	U_R	Para. 9.3.2	Para. 9.3.2	6.3 2.5 1.3	19.8 9.0 4.5	V
3	Latch Time	t_L	Para. 9.3.4	Para. 9.3.4	-	15	ms
4	Reset Time	t_r	Para. 9.3.4	Para. 9.3.4	-	15	ms
5	Bounce Time	t_b	Para. 9.3.4	Para. 9.3.4	-	1.0	ms
6	Insulation Resistance	R_i	Para. 9.3.7	Para. 9.3.7 at 500Vdc Note 1	50	-	M Ω

NOTES

1. This measurement shall be made only at the high temperature condition.
2. Limits Min. apply to measurements at -55°C and Limits Max. to +125°C.

FIGURE 4 - CIRCUITS FOR ELECTRICAL MEASUREMENTS

Not applicable.

TABLE 4 - MEASUREMENTS DURING SCREENING

No.	CHARACTERISTICS	SYMBOL	ESCC 3602 TEST METHOD	TEST CONDITIONS	MAXIMUM LIMIT	UNIT
10	Miss Test, Contact Resistance	R _C	Para. 9.8	Para. 9.8	100	Ω

TABLE 5(a) - CONDITIONS FOR SCREENING

No.	CHARACTERISTICS	SYMBOL	CONDITION	UNIT
1	Ambient High Temperature	T _{amb}	+ 125(+ 0 - 3)	°C
2	Ambient Low Temperature	T _{amb}	- 65(+ 3 - 0)	°C
3	Ambient Room Temperature	T _{amb}	+ 22 ± 3	°C

TABLE 5(b) - CONDITIONS FOR OPERATING LIFE TEST

No.	CHARACTERISTICS	SYMBOL	CONDITION	UNIT
1	Ambient High Temperature	T _{amb}	+ 125(+ 0 - 3)	°C
2	Contact Load Resistive	V I	28 15	V _{dc} A _{dc}

FIGURE 5(a) - ELECTRICAL CIRCUITS FOR SCREENING

Not applicable.

FIGURE 5(b) - ELECTRICAL CIRCUITS FOR OPERATING LIFE TEST

Not applicable.

- 4.8 ENVIRONMENTAL AND ENDURANCE TESTS (CHARTS IV AND V OF ESCC GENERIC SPECIFICATION No. 3602)
- 4.8.1 Measurements and Inspections on Completion of Environmental Tests
The parameters to be measured and inspections to be performed on completion of environmental tests are scheduled in Table 6. Unless otherwise stated, the measurements shall be performed at $T_{amb} = +22 \pm 3 \text{ }^\circ\text{C}$.
- 4.8.2 Measurements and Inspections during Endurance Tests
The parameters to be measured and inspections to be performed during endurance tests are scheduled in Table 6. Unless otherwise stated, the measurements shall be performed at $T_{amb} = +22 \pm 3 \text{ }^\circ\text{C}$.
- 4.8.3 Measurements and Inspections on Completion of Endurance Tests
The parameters to be measured and inspections to be performed on completion of endurance tests are scheduled in Table 6. Unless otherwise stated, the measurements shall be performed at $T_{amb} = +22 \pm 3 \text{ }^\circ\text{C}$.
- 4.8.4 Conditions for Operating Life Tests (Part of Endurance Testing)
The requirements for operating life testing are specified in Section 9 of ESCC Generic Specification No. 3602. The conditions for operating life testing shall be as specified in Table 5(b) of this specification.
- 4.8.5 Electrical Circuits for Operating Life Tests (Figure 5(b))
Not applicable.

TABLE 6 - MEASUREMENTS AND INSPECTIONS ON COMPLETION OF ENVIRONMENTAL TESTS AND AT INTERMEDIATE POINTS AND ON COMPLETION OF ENDURANCE TESTING

No.	ESCC GENERIC SPEC. NO. 3602		MEASUREMENTS AND INSPECTIONS		SYMBOL	LIMITS		UNIT
	ENVIRONMENTAL AND ENDURANCE TESTS (1)	TEST METHOD AND CONDITIONS	IDENTIFICATION	CONDITIONS		MIN.	MAX.	
01	Vibration	Para. 9.10 and Para. 4.2.4 of this spec.	Measurements during Test Contact Monitoring Final Measurements Visual Examination	ESCC 3602 Para. 9.10 -	- -	- -	- -	- -
02	Mechanical Shock	Para. 9.11 and Para. 4.2.4 of this spec.	Measurements during Test Contact Monitoring Final Measurements Electrical Measurements Visual Examination	ESCC 3602 Para. 9.11 Table 2 Items 7-8-1-2 -	- -	- -	- -	- -
03	Overload	Para. 9.12 and Table 1(b) Item 4 and Para. 4.2.4 of this spec.	Measurements during Test Contact Voltage Drop Final Measurements Fuse Continuity Contact Voltage Drop Insulation Resistance Voltage Proof (all Points) (2) Electrical Measurements	ESCC 3602 Para. 9.12.2 - Table 2 Item 8 Table 2 Item 6 Table 2 Item 7 Table 2 Items 1-2-3-4-5-9	V _d - V _d R _i VP	Para. 9.12.2 Continuity - 175 50 - 1000 - Table 2	mV mV MΩ Vrms	
04	Thermal Shock	Para. 9.13	During 5th Cycle Electrical Measurements at +125°C Electrical Measurements at -65°C Final Measurements Visual Examination Voltage Proof (all Points)	In Conditioning Chamber Table 3 Items 1-2-3-4-6 Table 3 Items 1-2-3-4 - Table 2 Item 7	- - VP	Table 3 Table 3 - Table 2	- - Vrms	
05	Salt Spray	Para. 9.14	Final Measurements Visual Examination Electrical Measurements Voltage Proof (all Points) (2)	- Table 2 Items 1-2-3-4-5-6-8-9 Table 2 Item 7	- - VP	- Table 2 1000 -	- - Vrms	
06	Intermediate Current	Para. 9.16 and Para. 4.2.5 of this spec.	Measurements during Test Contact Voltage Drop Final Measurements Insulation Resistance Voltage Proof (all Points) (2) Electrical Measurements Contact Voltage Drop (3)	ESCC 3602 Para. 9.16.2 Table 2 Item 6 Table 2 Item 7 Table 2 Items 1-2-3-4-5-9 ESCC 3602 Para. 9.16.2	V _d R _i VP V _d	Para. 9.16.2 50 - 1000 - Table 2 Para. 9.16.2	mV MΩ Vrms mV	
07	Terminal Strength	Para. 9.17 and Para. 4.3.3 of this spec.	Visual Examination	ESCC 3601 Para. 9.17.3	-	-	-	-

NOTES

1. The tests in this table refer to either Chart IV or V and shall be used as applicable.
2. 350Vrms between coils.
3. Reading time 5 to 10 seconds, if required.



TABLE 6 - MEASUREMENTS AND INSPECTIONS ON COMPLETION OF ENVIRONMENTAL TESTS AND AT INTERMEDIATE POINTS AND ON COMPLETION OF ENDURANCE TESTING (CONT'D)

No.	ESCC GENERIC SPEC. NO. 3602		MEASUREMENTS AND INSPECTIONS		SYMBOL	LIMITS		UNIT
	ENVIRONMENTAL AND ENDURANCE TESTS (1)	TEST METHOD AND CONDITIONS	IDENTIFICATION	CONDITIONS		MIN.	MAX.	
08	Resistance to Soldering Heat	Para. 9.18	Electrical Measurements	Table 2 Items 1-2-6-8-9		Table 2		
09	Operating Life Resistive	Para's 9.19, 9.19.1 and Table 5(b) of this spec.	Measurements during Test Contact Voltage Drop Final Measurements Fuse Continuity Contact Voltage Drop (3) Insulation Resistance Voltage Proof (all Points) (2) Electrical Measurements	ESCC 3602 Para. 9.19.1 - Table 2 Item 8 Table 2 Item 6 Table 2 Item 7 Table 2 Items 1-2-3-4-5-9	V _d - V _d R _i VP	Para. 9.19.1 Continuity - 175 50 - 1000 - Table 2	mV mV MΩ Vrms	
10	Inductive Life	Para. 9.19.3 and Table 1(b) Item 5 of this spec.	Measurements during Test Contact Voltage Drop Final Measurements Fuse Continuity Contact Voltage Drop (3) Insulation Resistance Voltage Proof (all Points) (2) Electrical Measurements	ESCC 3602 Para. 9.19.1 - Table 2 Item 8 Table 2 Item 6 Table 2 Item 7 Table 2 Items 1-2-3-4-5-9	V _d - V _d R _i VP	Para. 9.19.1 Continuity - 175 50 - 1000 - Table 2	mV mV MΩ Vrms	
11	Mechanical Life	Para. 9.19.4	Final Measurements Contact Voltage Drop Electrical Measurements	Table 2 Item 8 Table 2 Items 1-2-3-4-5-9		- 175 Table 2	mV	

NOTES

1. The tests in this table refer to either Chart IV or V and shall be used as applicable.
2. 350Vrms between coils.
3. Reading time 5 to 10 seconds, if required.