



Page 1 to 18

**CONTACTS, ELECTRICAL, CRIMP, SOLDER  
FOR 3401/007 AND 3401/008 CONNECTORS  
ESCC Detail Specification No. 3401/009**

**ISSUE 3  
January 2012**



Document Custodian: European Space Agency - see <https://escies.org>

	ESCC Detail Specification No. 3401/009		PAGE ii ISSUE 3
---	---	--	--------------------

### **LEGAL DISCLAIMER AND COPYRIGHT**

European Space Agency, Copyright © 2012. All rights reserved.

The European Space Agency disclaims any liability or responsibility, to any person or entity, with respect to any loss or damage caused, or alleged to be caused, directly or indirectly by the use and application of this ESCC publication.

This publication, without the prior permission of the European Space Agency and provided that it is not used for a commercial purpose, may be:

- copied in whole, in any medium, without alteration or modification.
- copied in part, in any medium, provided that the ESCC document identification, comprising the ESCC symbol, document number and document issue, is removed.

**DOCUMENTATION CHANGE NOTICE**

DCR No.	CHANGE DESCRIPTION
682	Specification upissued to incorporate technical changes per DCR.

	<p style="text-align: center;">ESCC Detail Specification No. 3401/009</p>		<p>PAGE 3 ISSUE 3</p>
---	---	--	---------------------------

**TABLE OF CONTENTS**

		<u>Page</u>
<b>1.</b>	<b><u>GENERAL</u></b>	<b>5</b>
1.1	Scope	5
1.2	Component Type Variants	5
1.3	Maximum Ratings	5
1.4	Parameter Derating Information	5
1.5	Physical Dimensions	5
<b>2.</b>	<b><u>APPLICABLE DOCUMENTS</u></b>	<b>5</b>
<b>3.</b>	<b><u>TERMS, DEFINITIONS, ABBREVIATIONS, SYMBOLS AND UNITS</u></b>	<b>5</b>
<b>4.</b>	<b><u>REQUIREMENTS</u></b>	<b>13</b>
4.1	General	13
4.2	Deviations from Generic Specification	13
4.2.1	Deviations from Special In-Process Controls	13
4.2.2	Deviations from Final Production Tests	13
4.2.3	Deviations from Burn-in and Electrical Measurements	13
4.2.4	Deviations from Qualification Tests	13
4.2.5	Deviations from Lot Acceptance Test	13
4.3	Mechanical Requirements	13
4.3.1	Dimension Check	13
4.3.2	Weight	13
4.3.3	Contact Capability	13
4.3.4	Contact Retention	13
4.3.5	Mating and Unmating Forces	13
4.3.6	Insert Retention	13
4.3.7	Jackscrew Retention	14
4.3.8	Contact Insertion and Withdrawal Forces	14
4.3.9	Engagement and Separation Forces	14
4.3.10	Oversize Pin Exclusion	14
4.3.11	Probe Damage	14
4.3.12	Solderability	14
4.4	Materials and Finishes	14
4.4.1	Shell, Coupling Ring and Nut	14
4.4.2	Inserts	14
4.4.3	Contacts	14
4.4.4	Contact Retaining Clip	14
4.4.5	Guiding and Locking Devices	15
4.4.6	Magnetism Level	15
4.5	Marking	15
4.5.1	General	15
4.5.2	The ESCC Component Number	15
4.5.3	Traceability Information	15
4.6	Electrical Measurements	15
4.6.1	Electrical Measurements at Room Temperature	15
4.6.2	Electrical Measurements at High and Low Temperatures	15
4.6.3	Circuits for Electrical Measurements	15
4.7	Screening Tests	15

	<p style="text-align: center;">ESCC Detail Specification No. 3401/009</p>		<p>PAGE 4 ISSUE 3</p>
---	---	--	---------------------------

	<u>Page</u>
4.8 Environmental and Endurance Tests	16
4.8.1 Measurements and Inspections on Completion of Environmental Tests	16
4.8.2 Measurements and Inspections at Intermediate Points during Endurance Tests	16
4.8.3 Measurements and Inspections on Completion of Endurance Tests	16
4.8.4 Conditions for Operating Life Tests	16
4.8.5 Electrical Circuits for Operating Life Tests	16
4.8.6 Conditions for High Temperature Storage Test	16

**TABLES**

1(a) Type Variants	6
1(b) Maximum Ratings	8
2 Electrical Measurements at Room Temperature	16

**FIGURES**

1 Parameter Derating Information	N/A
2 Physical Dimensions	9
3 Not applicable	N/A
4 Not applicable	N/A
5 Not applicable	N/A
6 Measurements and Inspections on Completion of Environmental and Endurance Testing	17

	<p style="text-align: center;">ESCC Detail Specification No. 3401/009</p>	<p>PAGE 5 ISSUE 3</p>
---	---	---------------------------

**1. GENERAL**

**1.1 SCOPE**

This specification details the ratings, physical and electrical characteristics, test and inspection data for Contacts, Electrical, Crimp, Solder, Gauge 20, 16, 12 and 8 for 3401/007 and 3401/008 Connectors.

These contacts shall be packed separately from the connectors and may be procured either with the connectors or separately.

This specification shall be read in conjunction with:

- ESCC Generic Specification No. 3401, Connectors, Electrical, Non-Filtered, Circular and Rectangular.
- ESCC Detail Specification No. 3401/007, Connectors, Miniature, Electrical, Circular, Bayonet Coupling, Removable Crimp Contacts, Based on Type DFE.
- ESCC Detail Specification No. 3401/008, Connectors, Miniature, Electrical, Circular, Push-Pull Coupling, Removable Crimp Contacts, Based on Type DBAS.

the requirements of which are supplemented herein.

**1.2 COMPONENT TYPE VARIANTS**

Variants of the basic type of contacts specified herein, which are also covered by this specification, are scheduled in Table 1(a).

**1.3 MAXIMUM RATINGS**

The maximum ratings, which shall not be exceeded at any time during use or storage, applicable to the contacts specified herein, are scheduled in Table 1(b).

**1.4 PARAMETER DERATING INFORMATION (FIGURE 1)**

Not applicable.

**1.5 PHYSICAL DIMENSIONS**

The physical dimensions of the contacts specified herein are shown in Figure 2.

**2. APPLICABLE DOCUMENTS**

The following documents form part of this specification and shall be read in conjunction with it:-

- (a) ESCC Generic Specification No. 3401, Connectors, Electrical, Non-Filtered, Circular and Rectangular.
- (b) ESCC Detail Specification No. 3401/007, Connectors, Miniature, Electrical, Circular, Bayonet-Coupling, Removable Crimp Contacts, Based on Type DFE.
- (c) ESCC Detail Specification No. 3401/008, Connectors, Miniature, Electrical, Circular, Push-Pull Coupling, Removable Crimp Contacts, Based on Type DBAS.
- (d) MIL-G-45204, Gold-plating, Electro-deposited.
- (e) MIL-C-14550, Copper-plating, Electro-deposited.

**3. TERMS, DEFINITIONS, ABBREVIATIONS, SYMBOLS AND UNITS**

For the purpose of this specification, the terms, definitions, abbreviations, symbols and units specified in ESCC Basic Specification No. 21300 shall apply.

**TABLE 1(a) - TYPE VARIANTS**

Variant	Type	Mating End	Crimp Barrel	Rated Current (A)	Accepted Wire (AWG)	Max. Weight (g)	Engagement & Separation		Test Pin Dia (mm)		Contact Capability		Contact Retent. Force Max. (N)	Contact Insert/ Withdr. Force Max. (N)	Probe Damage			Oversize Pin Excl.		
							Engag. Max. (N) (1)	Separ. Min. (N) (1)	Min.	Max.	Weight	Drop			Moment (N.cm)	Probe Dia (mm)	Force Max. (N)	Test Pin Dia (mm)		
01	Male	20 Red	20 Red	7.5	20 24	0.32	-	-	-	-	-	70	44	-	-	-	-	-		
02	Female	20 Red	20 Red	7.5	20 24	0.32	3.33 0.28	2.22 0.20	1.039 0.990	1.042 0.993	28.35	226.8	44	44	5.75	0.99	1.01	3.4	1.17	1.18
03	Male	20 Red	18 Violet	7.5	18 22	0.32	-	-	-	-	-	70	44	-	-	-	-	-	-	-
04	Female	20 Red	18 Violet	7.5	18 22	0.32	3.33 0.28	2.22 0.20	1.039 0.990	1.042 0.993	28.35	226.8	44	44	5.75	0.99	1.01	3.4	1.17	1.18
05	Male	20 Red	26 White	2.5	26 28	0.32	-	-	-	-	-	70	44	-	-	-	-	-	-	-
06	Female	20 Red	26 White	2.5	26 28	0.32	3.33 0.28	2.22 0.20	1.039 0.990	1.042 0.993	28.35	226.8	44	44	5.75	0.99	1.01	3.4	1.17	1.18
07	Male	16 Blue	16 Blue	13	16 20	0.60	-	-	-	-	-	116	44	-	-	-	-	-	-	-
08	Female	16 Blue	16 Blue	13	16 20	0.64	5.55 0.56	3.75 0.56	1.610 1.562	1.613 1.565	56.70	382.6	44	44	23	1.56	1.58	5.6	1.73	1.74
09	Male	16 Blue	20 Red	7.5	20 24	0.60	-	-	-	-	-	116	44	-	-	-	-	-	-	-
10	Female	16 Blue	20 Red	7.5	20 24	0.64	5.55 0.56	3.75 0.56	1.610 1.562	1.613 1.565	56.70	382.6	44	44	23	1.56	1.58	5.6	1.73	1.74
11	Male	12 Yellow	12 Yellow	25	12 14	1.25	-	-	-	-	-	116	44	-	-	-	-	-	-	-
12	Female	12 Yellow	12 Yellow	25	12 14	1.25	8.40 0.83	5.56 0.85	2.411 2.362	2.413 2.365	84	567	44	44	23	2.36	2.38	8.4	2.53	2.54
13	Male	12 Yellow	16 Blue	13	16 20	1.25	-	-	-	-	-	116	44	-	-	-	-	-	-	-

**NOTES :** See Page 7.



ESCC Detail Specification  
No. 3401/009

PAGE 7

ISSUE 3

**TABLE 1(a) - TYPE VARIANTS**

Variant	Type	Mating End	Crimp Barrel	Rated Current (A)	Accepted Wire (AWG)	Max. Weight (g)	Engagement & Separation		Test Pin Dia (mm)		Contact Capability			Contact Retent. Force Max. (N)	Contact Insert/ Withdr. Force Max. (N)	Probe Damage			Oversize Pin Excl.	
							Engag. Max. (N) (1)	Separ. Min. (N) (1)	Min.	Max.	Pick-up (g) (2)	Weight Drop (g) (3)	Moment (N.cm)			Probe Dia (mm) Min.	Probe Dia (mm) Max.	Force Max. (N)	Test Pin Dia (mm) Min.	Test Pin Dia (mm) Max.
14	Female	12 Yellow	16 Blue	13	16 20	1.25	8.40 0.83	5.56 0.85	2.411 2.362	2.413 2.365	- 84	567 -	116	44	23	2.36	2.38	8.4	2.53	2.54
15	Male	8 Red	8 Red	45	8	1.25	-	-	-	-	-	116	44	-	-	-	-	-	-	-
16	Female	8 Red	8 Red	45	8	1.25	45.40 1.40	45.40 1.40	4.960 4.892	4.963 4.905	- 141.75	4536 -	116	44	23	4.88	4.90	N/A	N/A	N/A
17	Male	8 Red	10 Red	32	10	1.25	-	-	-	-	-	116	44	-	-	-	-	-	-	-
18	Female	8 Red	10 Red	32	10	1.25	45.40 1.40	45.40 1.40	4.960 4.892	4.963 4.905	- 141.75	4536 -	116	44	23	4.88	4.90	N/A	N/A	N/A
19	Male	8 (4)	8 (4)	45	8	1.25	-	-	-	-	-	116	44	-	-	-	-	-	-	-
20	Female	8 (4)	8 (4)	45	8	1.25	45.40 1.40	45.40 1.40	4.960 4.892	4.963 4.905	- 141.75	4536 -	116	44	23	4.88	4.90	N/A	N/A	N/A

**NOTES**

1. 1st line with maximum diameter test pin; 2nd line with minimum diameter test pin.
2. With minimum diameter test pin and minimum insertion depth of 4.0mm.
3. With maximum diameter test pin and minimum insertion depth of 4.0mm.
4. These contacts are not colour coded.



**TABLE 1(b) - MAXIMUM RATINGS**

No.	CHARACTERISTICS	SYMBOL	MAXIMUM RATINGS	UNITS
1	Rated Current	$I_{CR}$	See Table 1(a)	A
2	Operating Temperature Range	$T_{op}$	-65 to +200	°C
3	Storage Temperature Range	$T_{stg}$	-65 to +200	°C

**FIGURE 1 - PARAMETER DERATING INFORMATION**

Not applicable.

**FIGURE 2 - PHYSICAL DIMENSIONS**

VARIANTS 01-03-05-07-09-11-13, MALE CONTACT

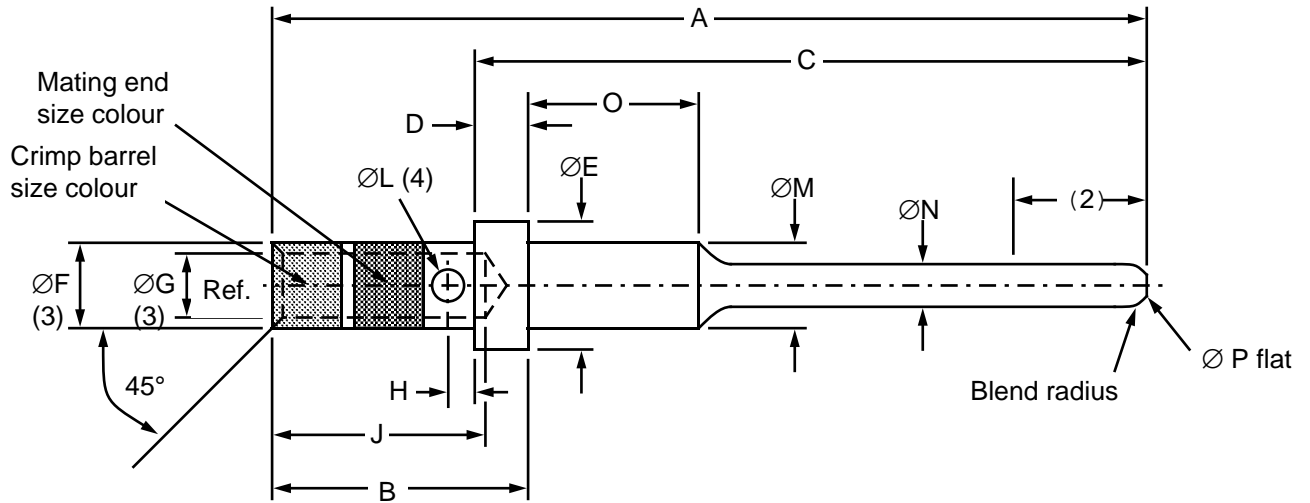

CONDUCTOR BARREL SHAPE FOR VARIANTS 05-09-11-13

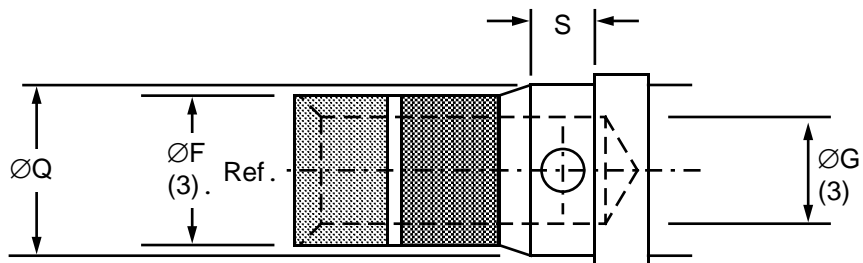

Variant	Dimensions	A	B	C	D	ØE	ØF	ØG	H	J	ØL	ØM	ØN	O	ØP	ØQ	S
01	Min.	-	4.82	13.80	0.74	2.53	1.92	1.21	0.63	4.07	0.67	1.92	0.99	3.09	-	-	-
	Max.	18.39	5.18	13.95	0.84	2.61	1.98	1.27	0.89	4.67	0.81	1.98	1.05	3.35	0.30	-	-
03	Min.	-	4.82	13.80	0.74	2.53	1.92	1.31	0.63	4.07	0.67	1.92	0.99	3.09	-	-	-
	Max.	18.39	5.18	13.95	0.84	2.61	1.98	1.37	0.89	4.67	0.81	1.98	1.05	3.35	0.30	-	-
05	Min.	-	4.82	13.80	0.74	2.53	1.44	0.61	0.63	4.07	0.67	1.92	0.99	3.09	-	1.92	1.27
	Max.	18.39	5.18	13.95	0.84	2.61	1.49	0.67	0.89	4.67	0.81	1.98	1.05	3.35	0.30	1.98	1.52
07	Min.	-	7.36	14.17	1.12	3.30	2.56	1.65	0.63	6.35	0.90	2.56	1.56	3.09	0.38	-	-
	Max.	20.95	7.75	14.32	1.22	3.38	2.62	1.73	0.89	7.21	1.07	2.62	1.61	3.35	0.63	-	-
09	Min.	-	7.36	14.17	1.12	3.30	1.92	1.21	0.63	6.35	0.90	2.56	1.56	3.09	0.38	2.56	1.27
	Max.	20.95	7.75	14.32	1.22	3.38	1.98	1.27	0.89	7.21	1.07	2.62	1.61	3.35	0.63	2.62	1.52
11	Min.	-	7.36	14.17	1.12	4.75	3.76	2.49	0.63	6.35	0.90	3.76	2.36	2.92	1.32	3.94	1.27
	Max.	20.95	2.75	14.32	1.22	4.83	3.83	2.59	0.89	7.21	1.07	3.83	2.41	3.05	1.57	4.01	1.52
13	Min.	-	7.36	14.17	1.12	4.75	2.56	1.65	0.63	6.35	0.90	3.76	2.36	2.92	1.32	3.94	1.27
	Max.	20.95	7.75	14.32	1.22	4.83	2.62	1.73	0.89	7.21	1.07	3.83	2.41	3.05	1.57	4.01	1.52

**NOTES**

- All dimensions are in millimetres.
- Measurement point for plating thickness= $4.0 \pm 1.0$ .
- ØF and ØG to be concentric within 0.10TIR.
- Inspection hole shall only penetrate one wall of the crimp barrel.

**FIGURE 2 - PHYSICAL DIMENSIONS (CONTINUED)**

VARIANTS 15-17, MALE CONTACT

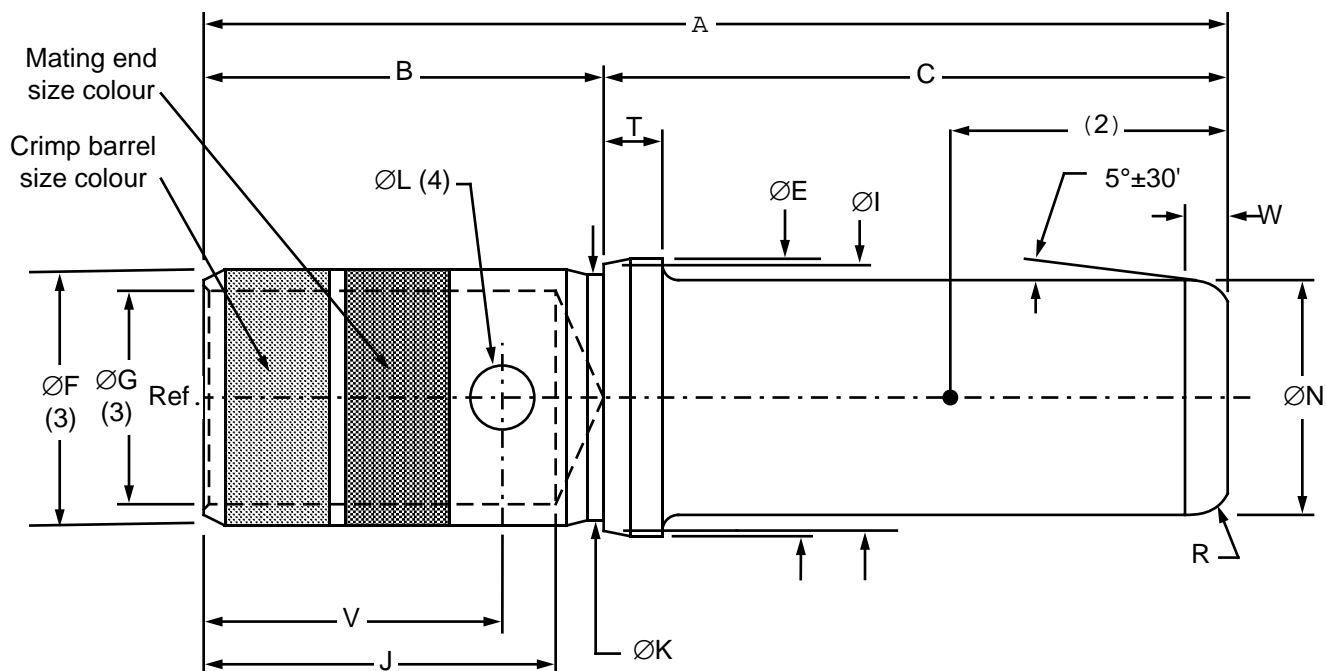

CONDUCTOR BARREL SHAPE FOR VARIANT 17

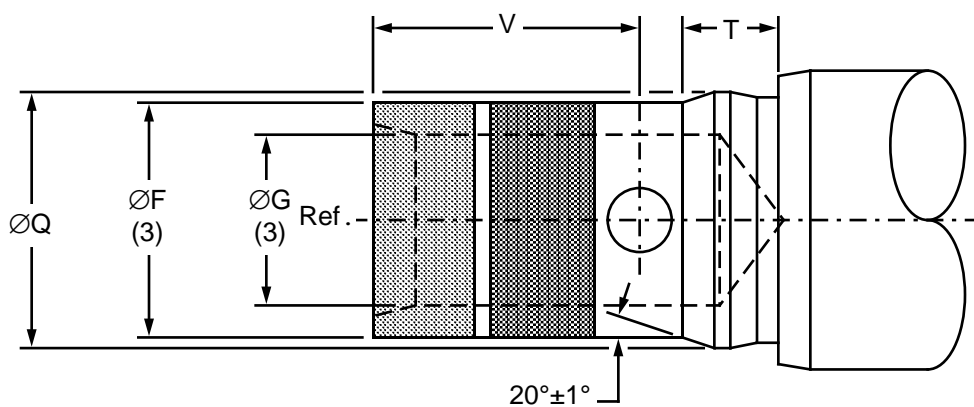

Variant	Dimensions	A	B	C	ØE	ØF	ØG	ØI	J	ØK	ØL	ØN	ØQ	R	T	V	W
15	Min.	-	8.47	13.79	6.25	5.62	4.51	6.08	7.03	5.26	1.15	4.90	-	0.50	1.41	6.13	0.75
	Max.	22.75	8.81	13.94	6.33	5.70	4.60	6.16	7.83	5.46	1.35	4.96	-	-	1.53	6.59	1.05
17	Min.	-	8.47	13.79	6.25	4.96	3.45	6.08	7.03	5.26	1.15	4.90	5.62	0.50	1.87	5.78	0.75
	Max.	22.75	8.81	13.94	6.33	5.08	3.54	6.16	7.83	5.46	1.35	4.96	5.70	-	2.13	6.04	1.05

**NOTES**

1. All dimensions are in millimetres.
2. Measurement point for plating thickness= 4.0±1.0.
3. ØF and ØG to be concentric within 0.10TIR.
4. Inspection hole shall only penetrate one wall of crimp barrel.

**FIGURE 2 - PHYSICAL DIMENSIONS (CONTINUED)**  
**VARIANT 19, MALE CONTACT**

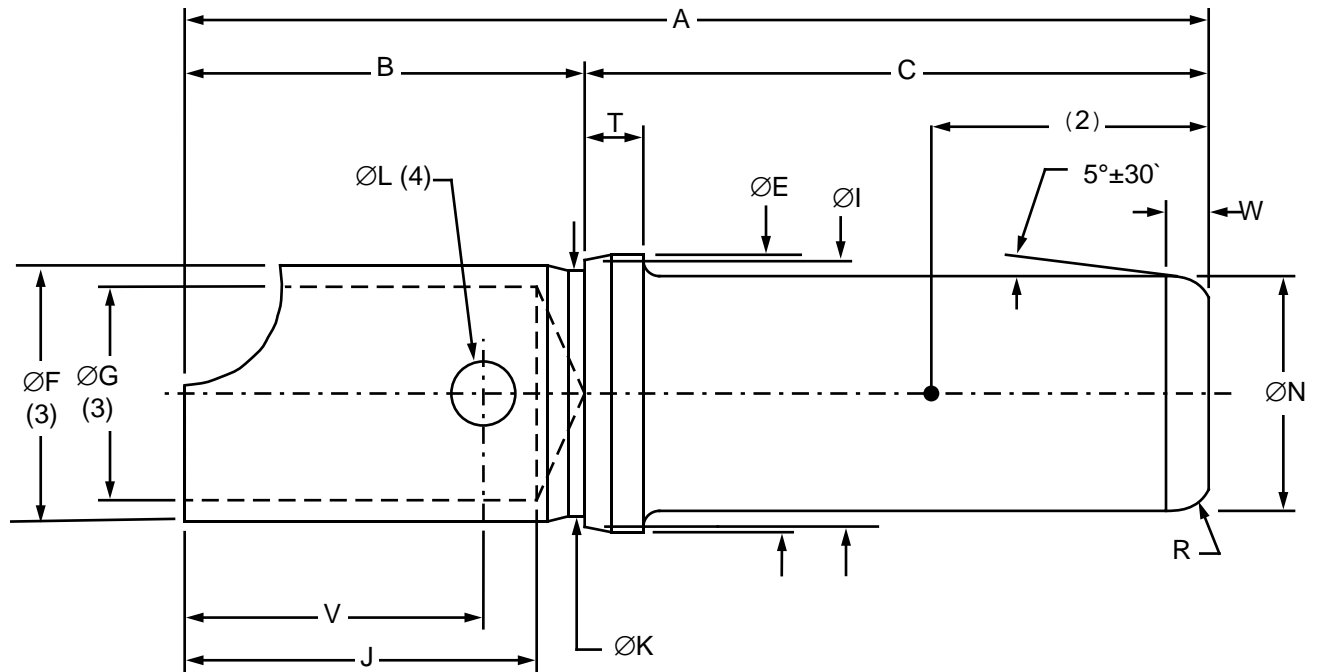

Variant	Dimensions	A	B	C	ØE	ØF	ØG	ØI	J	ØK	ØL	ØN	ØQ	R	T	V	W
19	Min.	-	8.47	13.79	6.25	5.62	4.51	6.08	7.15	5.26	1.15	4.90	-	-	1.41	6.13	0.75
	Max.	22.75	8.81	13.94	6.33	5.70	4.60	6.16	7.65	5.46	1.35	4.96	-	0.50	1.53	6.59	1.05

**NOTES**

1. All dimensions are in millimetres.
2. Measurement point for plating thickness= 4.0±1.0.
3. ØF and ØG to be concentric within 0.10TIR.
4. Inspection hole shall only penetrate one wall of the solder barrel.

**FIGURE 2 - PHYSICAL DIMENSIONS (CONTINUED)**

VARIANTS 02-04-06-08-10-12-14, FEMALE CONTACT

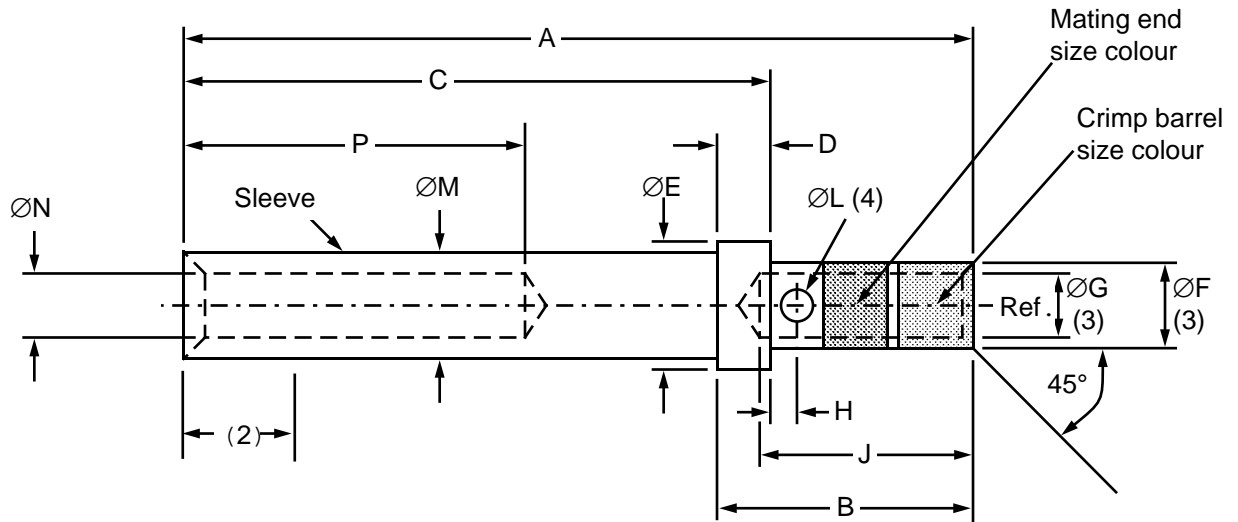

**CONDUCTOR BARREL SHAPE FOR VARIANTS 06-10-12-14**

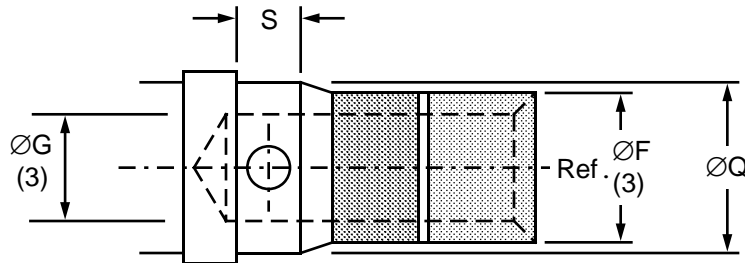

Variant	Dimensions	A	B	C	D	ØE	ØF	ØG	H	J	ØL	ØM	ØN	P	ØQ	S
02	Min.	-	4.82	12.17	0.74	2.53	1.92	1.21	0.63	4.07	0.67	1.92	1.06	8.4	-	-
	Max.	16.76	5.18	12.32	0.84	2.61	1.98	1.27	0.89	4.67	0.81	1.98	1.12	9.4	-	-
04	Min.	-	4.82	12.17	0.74	2.53	1.92	1.31	0.63	4.07	0.67	1.92	1.06	8.4	-	-
	Max.	16.76	5.18	12.32	0.84	2.61	1.98	1.37	0.89	4.67	0.81	1.98	1.12	9.4	-	-
06	Min.	-	4.82	12.17	0.74	2.53	1.44	0.61	0.63	4.07	0.67	1.92	1.06	8.4	1.92	1.27
	Max.	16.76	5.18	12.32	0.84	2.61	1.49	0.67	0.89	4.67	0.81	1.98	1.12	9.4	1.98	1.52
08	Min.	-	7.36	12.55	1.12	3.30	2.56	1.65	0.63	6.35	0.90	2.79	1.65	8.4	-	-
	Max.	19.33	7.75	12.70	1.22	3.38	2.62	1.73	0.89	7.21	1.07	2.87	1.73	9.4	-	-
10	Min.	-	7.36	12.55	1.12	3.30	1.92	1.21	0.63	6.35	0.90	2.79	1.65	8.4	2.56	1.27
	Max.	19.33	7.75	12.70	1.22	3.38	1.98	1.27	0.89	7.21	1.07	2.87	1.73	9.4	2.62	1.52
12	Min.	-	7.36	12.55	1.12	4.75	3.76	2.49	0.63	6.35	0.90	4.01	2.46	8.4	3.94	1.27
	Max.	19.33	7.75	12.70	1.22	4.83	3.83	2.59	0.89	7.21	1.07	4.09	2.54	9.4	4.01	1.52
14	Min.	-	7.36	12.55	1.12	4.75	2.56	1.65	0.63	6.35	0.90	4.01	2.46	8.4	3.94	1.27
	Max.	19.33	7.75	12.70	1.22	4.83	2.62	1.73	0.89	7.21	1.07	4.09	2.54	9.4	4.01	1.52

**NOTES**

1. All dimensions are in millimetres.
2. Measurement point for plating thickness=2.0±1.0.
3. ØF and ØG to be concentric within 0.10TIR.
4. Inspection hole shall only penetrate one wall on the crimp barrel.

**FIGURE 2 - PHYSICAL DIMENSIONS (CONTINUED)**

VARIANTS 16-18, FEMALE CONTACT

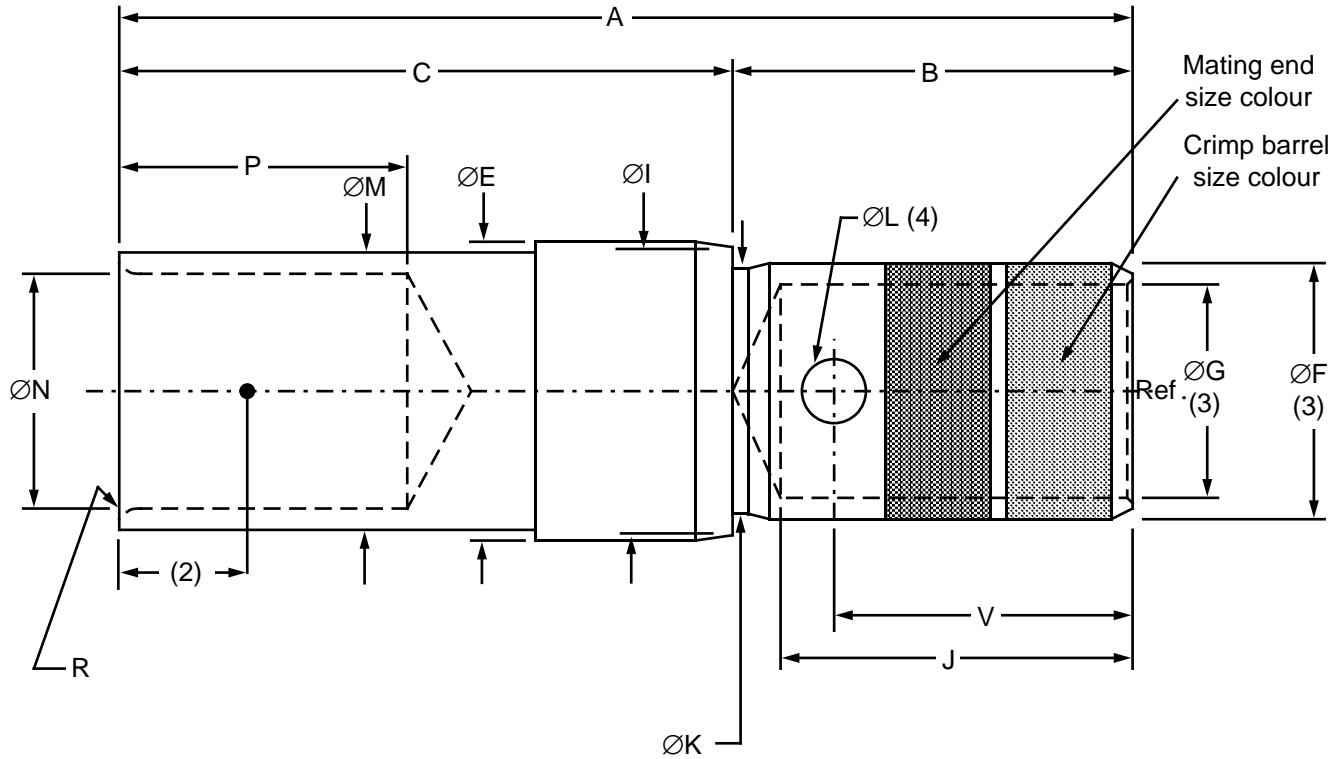

CONDUCTOR BARREL SHAPE FOR VARIANT 18

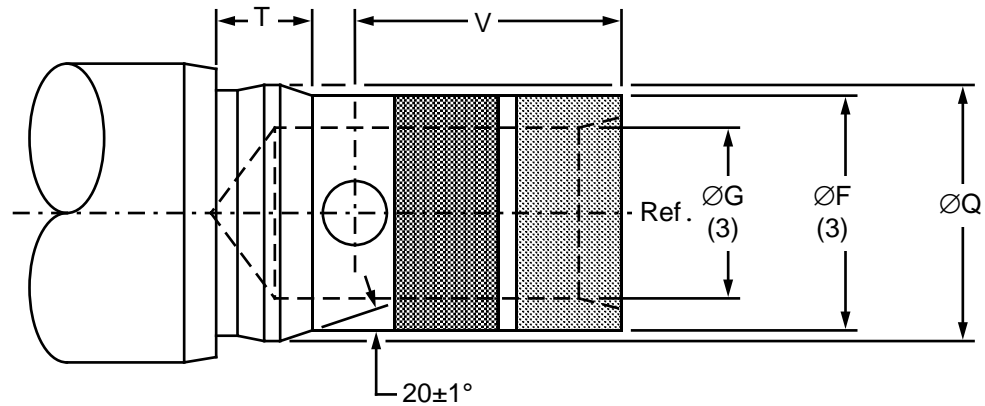

Variant	Dimensions	A	B	C	ØE	ØF	ØG	ØI	J	ØK	ØL	ØM	ØN	P	ØQ	R	T	V
16	Min.	-	8.47	13.09	6.25	5.62	4.51	6.08	7.03	5.26	1.15	6.17	4.98	6.21	-	0.12	-	6.13
	Max.	22.02	8.81	13.21	6.33	5.70	4.60	6.16	7.83	5.46	1.35	6.21	5.08	6.75	-	-	-	6.59
18	Min.	-	8.47	13.09	6.25	4.96	3.45	6.08	7.03	5.26	1.15	6.17	4.98	6.21	5.62	0.12	1.87	5.78
	Max.	22.02	8.81	13.21	6.33	5.08	3.54	6.16	7.83	5.46	1.35	6.21	5.08	6.75	5.70	-	2.13	6.04

**NOTES**

1. All dimensions are in millimetres.
2. Measurement point for plating thickness=4.0±1.0.
3. ØF and ØG to be concentric within 0.10TIR.
4. Inspection hole shall only penetrate one wall of crimp barrel.

**FIGURE 2 - PHYSICAL DIMENSIONS (CONTINUED)**

VARIANT 20, FEMALE CONTACT

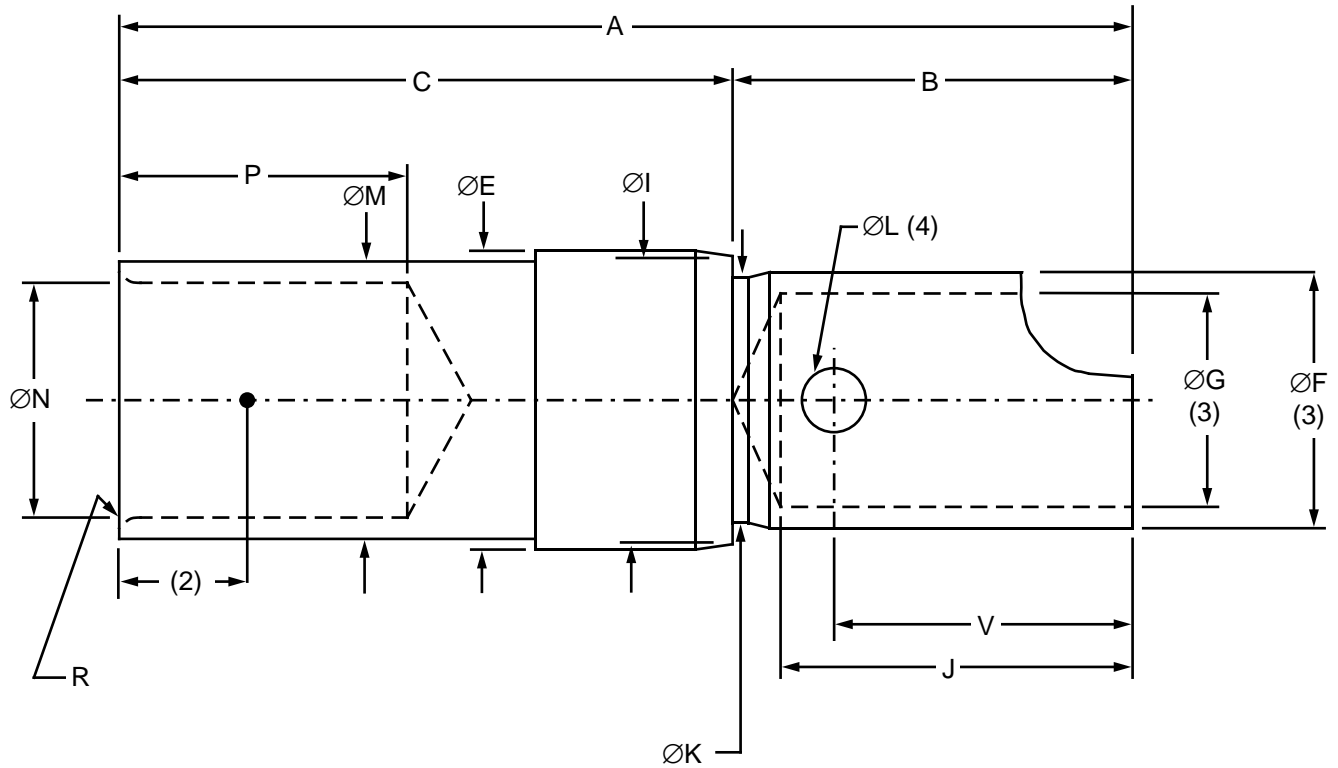

Variant	Dimensions	A	B	C	ØE	ØF	ØG	ØI	J	ØK	ØL	ØM	ØN	P	ØQ	R	T	V
20	Min.	-	8.47	13.09	6.25	5.62	4.51	6.08	7.15	5.26	1.15	6.17	4.98	6.21	-	0.12	-	6.13
	Max.	22.02	8.81	13.21	6.33	5.70	4.60	6.16	7.65	5.46	1.35	6.21	5.08	6.75	-	-	-	6.65

**NOTES**

1. All dimensions are in millimetres.
2. Measurement point for plating thickness=4.0±1.0.
3. ØF and ØG to be concentric within 0.10TIR.
4. Inspection hole shall only penetrate one wall of the solder barrel.

	<p style="text-align: center;">ESCC Detail Specification No. 3401/009</p>	<p style="text-align: right;">PAGE 13 ISSUE 3</p>
---	---	---

#### 4. REQUIREMENTS

##### 4.1 GENERAL

The complete requirements for procurement of the contacts specified herein shall be as stated in this specification and ESCC Generic Specification No. 3401. Deviations from the Generic Specification, applicable to this specification only, are listed in Para. 4.2.

Deviations from the applicable Generic Specification and this Detail Specification, formally agreed with specific Manufacturers on the basis that the alternative requirements are equivalent to the ESCC requirements and do not affect the components` reliability, are listed in the appendices attached to this specification.

##### 4.2 DEVIATIONS FROM GENERIC SPECIFICATION

###### 4.2.1 Deviations from Special In-process Controls

None.

###### 4.2.2 Deviations from Final Production Tests (Chart II)

None.

###### 4.2.3 Deviations from Burn-in and Electrical Measurements (Chart III)

Not applicable.

###### 4.2.4 Deviations from Qualification Tests (Chart IV)

(a) Para. 9.31, Solderability: Not applicable for Variants 01 to 18.

###### 4.2.5 Deviations from Lot Acceptance Tests (Chart V)

(a) Para. 9.31, Solderability: Not applicable for Variants 01 to 18.

##### 4.3 MECHANICAL REQUIREMENTS

###### 4.3.1 Dimension Check

The dimensions of the contacts specified herein shall be checked and conform to those shown in Figure 2.

###### 4.3.2 Weight

The maximum weight of the contacts specified herein shall conform to the requirements of Table 1(a).

###### 4.3.3 Contact Capability

For the purpose of this test, the pick-up and drop weights shall be as specified in Table 1(a).

###### 4.3.4 Contact Retention (In Insert)

The contact retention within the insert shall be as specified in Table 1(a).

###### 4.3.5 Mating and Unmating Forces

As specified in ESCC Detail Specification Nos. 3401/007 and 3401/008.

###### 4.3.6 Insert Retention (In Shell)

As specified in ESCC Detail Specification Nos. 3401/007 and 3401/008.



	<p style="text-align: center;">ESCC Detail Specification No. 3401/009</p>	<p style="text-align: right;">PAGE 14 ISSUE 3</p>
---	---	---

4.3.7 Jackscrew Retention

As specified in ESCC Detail Specification Nos. 3401/007 and 3401/008.

4.3.8 Contact Insertion and Withdrawal Forces

The contact insertion and withdrawal forces shall be as specified in Table 1(a).

4.3.9 Engagement and Separation Forces

The diameter of the test pin and the contact engagement and separation force of the female contacts shall be as specified in Table 1(a).

4.3.10 Oversize Pin Exclusion

The diameter of the test pin and the force applied to it shall be as specified in Table 1(a).

4.3.11 Probe Damage

The probe diameter and the moment at the end of the probe shall be as specified in Table 1(a).

4.3.12 Solderability

Size A soldering iron shall be used. Only applicable to Variants 19 and 20.

4.4 MATERIALS AND FINISHES

The materials and finishes shall be as specified herein. Where a definite material is not specified, a material which will enable the contacts specified herein to meet the performance requirements of this specification shall be used. Acceptance or approval of any constituent material does not guarantee acceptance of the finished product.

4.4.1 Shell, Coupling Ring and Nut

As specified in ESCC Detail Specification Nos. 3401/007 and 3401/008.

4.4.2 Inserts

As specified in ESCC Detail Specification Nos. 3401/007 and 3401/008.

4.4.3 Contacts

4.4.3.1 Body

The contact body shall be made of copper base alloy selected from raw materials with a minimum of impurities. It shall be plated as follows:

- 1.27µm minimum gold plate in accordance with MIL-G-45204 Type II Grade C over 1.5µm minimum nickel plate over 4.0 to 5.1 µm copper plate in accordance with MIL-C-14550.

4.4.3.2 Sleeves

The sleeves of female contacts shall be made of Monel.

4.4.4 Contact Retaining Clip

As specified in ESCC Detail Specification Nos. 3401/007 and 3401/008.

4.4.5 Guiding and Locking Devices

Not applicable.

4.4.6 Magnetism Level

As specified in ESCC Detail Specification Nos. 3401/007 and 3401/008.

4.5 MARKING

4.5.1 General

The marking of all components delivered to this specification shall be in accordance with the requirements of ESCC Basic Specification No. 21700 and the following paragraphs. These components being too small to accommodate the marking, the marking requirements in full shall accompany each lot of components in its primary package.

Such marking shall comprise:-

- (a) The ESCC Component Number.
- (b) Traceability Information.

4.5.2 The ESCC Component Number

The ESCC Component Number shall be constituted and marked as follows:

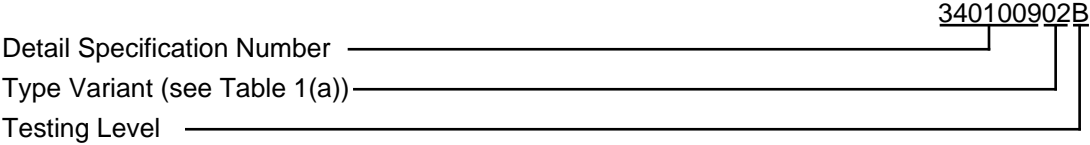

4.5.3 Traceability Information

Traceability information shall be marked in accordance with the requirements of ESCC Basic Specification No. 21700.

4.6 ELECTRICAL MEASUREMENTS

4.6.1 Electrical Measurements at Room Temperature

The parameters to be measured in respect of electrical characteristics are listed in Table 2. Unless otherwise specified, the measurements shall be performed at  $T_{amb}=+22\pm3$  °C.

4.6.2 Electrical Measurements at High and Low Temperatures (Table 3)

Not applicable.

4.6.3 Circuits for Electrical Measurements (Figure 4)

Not applicable.

4.7 SCREENING TESTS (TABLES 4 AND 5)

Not applicable.

**TABLE 2 - ELECTRICAL MEASUREMENTS AT ROOM TEMPERATURE**

No.	CHARACTERISTICS	SYMBOL	SPEC. AND/OR TEST METHOD	TEST CONDITIONS	VARIANTS	LIMITS		UNIT
						MIN.	MAX.	
1	Contact Resistance (Low Level Current)	Rcl	ESCC No. 3401 Para. 9.1.1.3	Para. 9.1.1.3	All	-	9.0	mΩ
2	Contact Resistance (Rated Current)	Rcr	ESCC No. 3401 Para. 9.1.1.3	Para. 9.1.1.3	Variants 01 - 06 Variants 07 - 14 Variants 15 - 20	-	8.0 6.0 1.0	mΩ

**TABLES 3, 4 AND 5**

Not applicable.

4.8 **ENVIRONMENTAL AND ENDURANCE TESTS (CHARTS IV AND V OF ESCC GENERIC SPECIFICATION No. 3401)**

4.8.1 **Measurements and Inspections on Completion of Environmental Tests**

The parameters to be measured and inspections to be performed on completion of environmental testing are scheduled in Table 6. Unless otherwise specified, the measurements shall be performed at  $T_{amb}=+22\pm 3$  °C.

4.8.2 **Measurements and Inspections at Intermediate Points during Endurance Tests**

Not applicable.

4.8.3 **Measurements and Inspections on Completion of Endurance Tests**

The parameters to be measured and inspections to be performed on completion of endurance tests shall be those specified in Table 6. Unless otherwise specified, the measurements shall be performed at  $T_{amb}=+22\pm 3$  °C.

4.8.4 **Conditions for Operating Life Tests (Part of Endurance Testing)**

Not applicable.

4.8.5 **Electrical Circuits for Operating Life Tests**

Not applicable.

4.8.6 **Conditions for High Temperature Storage Test (Part of Endurance Testing)**

Not applicable.

**TABLE 6 - MEASUREMENTS AND INSPECTIONS ON COMPLETION OF ENVIRONMENTAL AND ENDURANCE TESTING**

NO.	ESCC GENERIC NO. 3401		MEASUREMENTS AND INSPECTIONS		SYMBOL	LIMITS		UNIT
	ENVIRONMENTAL AND ENDURANCE TESTS (1)	TEST METHOD AND CONDITIONS	IDENTIFICATION	CONDITIONS		MIN	MAX	
01	Seal Test	Para. 9.9	ESCC 3401/007 or 3401/008					
02	Wiring	Para. 9.10 & Table 1(a) of this spec	Low Level Contact Resistance	Table 2 Item 1	Rcl	Table 2 Item 1		
03	Vibration	Para. 9.11	ESCC 3401/007 or 3401/008					
04	Shock or Bump	Para. 9.12	ESCC 3401/007 or 3401/008					
05	Climatic Sequence	Para. 9.13	ESCC 3401/007 or 3401/008					
06	Plating Thickness	Para. 9.14	Thickness	-	-	Para. 4.4.3 of this spec		
07	Joint Strength	Para. 9.15	ESCC 3401 Para 9.15					
08	Rapid Change of Temperature	Para. 9.16	ESCC 3401/007 or 3401/008					
09	Contact Retention (In Insert)	Para. 9.17 & Para. 4.3.4 of this spec	Contact Displacement		-	ESCC 3401 Para. 9.17		
10	Endurance	Para. 9.18	<u>Initial Measurements</u> Low Level Contact Resist	Table 2 Item 1	Rcl	Record Values		
			<u>Final Measurements</u> Low Level Contact Resistance Drift	Table 2 Item 1	ΔRcl	-	3.0	mΩ
11	Permanence of Marking	Para. 9.19	As applicable					
12	Mating/Unmating Forces	Para. 9.20	ESCC 3401/007 or 3401/008					
13	High Temperature Storage	Para. 9.21	<u>Initial Measurements</u> Low Level Contact Resist	Table 2 Item 1	Rcl	Record Values		
			<u>Final Measurements</u> Low Level Contact Resistance Drift	Table 2 Item 1	ΔRcl	-	3.0	mΩ
			Rated Current Contact Resistance	Table 2 Item 2	Rcr	Table 2 Item 2		
			Contact Retention (In Insert)	Para. 4.3.4 of this spec.	-	ESCC 3401 Para. 9.17		
14	Corrosion	Para. 9.22	Visual Examination	-	-	-	-	

**NOTES**

1. The tests in this table refer to either Chart IV or V and shall be used as applicable.



**TABLE 6 - MEASUREMENTS AND INSPECTIONS ON COMPLETION OF ENVIRONMENTAL AND ENDURANCE TESTING (CONT'D)**

NO.	ESCC GENERIC NO. 3401		MEASUREMENTS AND INSPECTIONS		SYMBOL	LIMITS		UNIT
	ENVIRONMENTAL AND ENDURANCE TESTS (1)	TEST METHOD AND CONDITIONS	IDENTIFICATION	CONDITIONS		MIN	MAX	
15	Insert Retention (In Shell)	Para. 9.23 & Para. 4.3.6 of this spec	ESCC 3401/007 or 3401/008					
16	Jackscrew Retention	Para. 9.24 & Para. 4.3.7 of this spec	ESCC 3401/007 or 3401/008					
17	High Temperature Measurements	Para. 9.25	ESCC 3401/007 or 3401/008					
18	Overload Test	Para. 9.26	Rated Current Contact Resistance	Table 2 Item 2	Rcr	Table 2 Item 2		
19	Maintenance Aging	Para. 9.27	Visual Examination Contact Retention  Contact Insertion & Withdrawal Forces	- Para. 4.3.4 of this spec. Para. 4.3.8 of this spec.	- - -	- - ESCC 3401 Para. 9.17 Para. 4.3.8		
20	Engage/Separation Forces	Para. 9.28 & Para. 4.3.9 of this spec	Force		F	Para. 4.3.9		
21	Oversize Pin Exclusion	Para. 9.29 & Para. 4.3.10 of this spec			-	ESCC 3401 Para. 9.29		
22	Probe Damage	Para. 9.30 & Para. 4.3.11 of this spec	Contact Separation Force	Para. 4.3.9 of this spec.	F	Para. 4.3.9		
23	Solderability	Para. 9.31 and Paras. 4.2.4 and 4.2.5 of this spec		Para. 4.3.12 of this spec.		ESCC 3401 Para. 9.31		

**NOTES**

1. The tests in this table refer to either Chart IV or V and shall be used as applicable.