



Pages 1 to 20

**CAPACITORS, FIXED, CERAMIC DIELECTRIC,  
TYPE II, HIGH CAPACITANCE, 50 to 500 V,  
BASED ON CASE STYLES BR, CV AND CH  
ESCC Detail Specification No. 3001/030**

**ISSUE 4  
May 2009**



Document Custodian: European Space Agency - see <https://escies.org>

	ESCC Detail Specification No. 3001/030		PAGE i ISSUE 4
---	---	--	-------------------

### LEGAL DISCLAIMER AND COPYRIGHT

European Space Agency, Copyright © 2009. All rights reserved.

The European Space Agency disclaims any liability or responsibility, to any person or entity, with respect to any loss or damage caused, or alleged to be caused, directly or indirectly by the use and application of this ESCC publication.

This publication, without the prior permission of the European Space Agency and provided that it is not used for a commercial purpose, may be:

- copied in whole in any medium without alteration or modification.
- copied in part, in any medium, provided that the ESCC document identification, comprising the ESCC symbol, document number and document issue, is removed.



ESCC Detail Specification  
No. 3001/030

PAGE 2  
ISSUE 4

**DOCUMENTATION CHANGE NOTICE**

(Refer to <https://escies.org> for ESCC DCR content)

DCR No.	CHANGE DESCRIPTION
484	Specification upissued to incorporate technical and editorial changes per DCR.

	<p style="text-align: center;">ESCC Detail Specification No. 3001/030</p>		<p>PAGE 3 ISSUE 4</p>
---	---	--	---------------------------

**TABLE OF CONTENTS**

		<u>Page</u>
<b>1.</b>	<b><u>GENERAL</u></b>	<b>5</b>
1.1	Scope	5
1.2	Component Type Variants and Range of Components	5
1.3	Maximum Ratings	5
1.4	Parameter Derating Information	5
1.5	Physical Dimensions	5
1.6	Functional Diagram	5
<b>2.</b>	<b><u>APPLICABLE DOCUMENTS</u></b>	<b>13</b>
<b>3.</b>	<b><u>TERMS, DEFINITIONS, ABBREVIATIONS, SYMBOLS AND UNITS</u></b>	<b>13</b>
<b>4.</b>	<b><u>REQUIREMENTS</u></b>	<b>13</b>
4.1	General	13
4.2	Deviations from Generic Specification	13
4.2.1	Deviations from Special In-process Controls	13
4.2.2	Deviations from Final Production Tests	13
4.2.3	Deviations from Burn-in and Electrical Measurements	13
4.2.4	Deviations from Qualification Tests	13
4.2.5	Deviations from Lot Acceptance Tests	13
4.3	Mechanical Requirements	14
4.3.1	Dimension Check	14
4.3.2	Weight	14
4.3.3	Robustness of Terminations	14
4.4	Materials and Finishes	14
4.4.1	Encapsulation	14
4.4.2	Leads	14
4.5	Marking	14
4.5.1	General	14
4.5.2	The ESCC Component Number	15
4.5.3	Electrical Characteristics and Ratings	15
4.5.4	Traceability Information	16
4.6	Electrical Measurements	16
4.6.1	Electrical Measurements at Room Temperature	16
4.6.2	Electrical Measurements at High and Low Temperatures	16
4.6.3	Circuits for Electrical Measurements	16
4.7	Burn-in Tests	16
4.7.1	Parameter Drift Values	16
4.7.2	Conditions for Burn-in	16
4.7.3	Electrical Circuit for Burn-in	16
4.8	Environmental and Endurance Tests	19
4.8.1	Measurements and Inspections on Completion of Environmental Tests	19
4.8.2	Measurements and Inspections at Intermediate Points during Endurance Tests	19
4.8.3	Measurements and Inspections on Completion of Endurance Tests	19
4.8.4	Conditions for Operating Life Tests	19
4.8.5	Electrical Circuit for Operating Life Tests	19



**TABLES**

	<u>Page</u>
1(a) Type Variants and Range of Components	6
1(b) Maximum Ratings	8
2 Electrical Measurements at Room Temperature	17
3 Electrical Measurements at High and Low Temperatures	17
4 Parameter Drift Values	18
5 Conditions for Burn-in and Operating Life Tests	18
6 Measurements and Inspections on Completion of Environmental Tests and at Intermediate Points and on Completion of Endurance Testing	20

**FIGURES**

1 Parameter Derating Information	N/A
2 Physical Dimensions	9
3 Functional Diagram	12
4 Circuits for Electrical Measurements	N/A
5 Electrical Circuit for Burn-in and Operating Life Tests	N/A

**APPENDICES (Applicable to specific Manufacturers only)**

'A' Agreed Deviations for AVX Ltd, Coleraine (G.B.)	22
---	----



1. GENERAL

1.1 SCOPE

This specification details the ratings, physical and electrical characteristics, test and inspection data for a Capacitor, Fixed, Ceramic Dielectric, Type II, High Capacitance, 50 to 500V, based on Case Styles BR, CV and CH. It shall be read in conjunction with ESCC Generic Specification No. 3001, the requirements of which are supplemented herein.

1.2 COMPONENT TYPE VARIANTS AND RANGE OF COMPONENTS

The variants and range of components covered by this specification are given in Table 1(a).

1.3 MAXIMUM RATINGS

The maximum ratings, which shall not be exceeded at any time during use or storage, applicable to the capacitors specified herein are scheduled in Table 1(b).

1.4 PARAMETER DERATING INFORMATION (FIGURE 1)

Not applicable.

1.5 PHYSICAL DIMENSIONS

The physical dimensions of the capacitors specified herein are shown in Figure 2.

1.6 FUNCTIONAL DIAGRAM

The functional diagram for the capacitors specified herein is shown in Figure 3.



**TABLE 1(a) - TYPE VARIANTS AND RANGE OF COMPONENTS**

Variant	Case Size	Total Number of Leads	Figure	Capacitance Range ( $\mu$ F) (E12)				Weight (g)
				50V	100V	200V	500V	
01	BR40	2	2(a)	1.8 to 3.3	1.2 to 2.7	0.33 to 0.56	0.12 to 0.22	2
02	BR50	2	2(a)	3.9 to 5.6	2.2 to 3.9	0.68 to 1	0.27 to 0.39	3
03	BR66	2	2(a)	6.8 to 10	4.7 to 8.2	1 to 2.2	0.47 to 1	5
04	BR72	2	2(a)	12 to 18	8.2 to 15	2.2 to 3.3	0.82 to 1.5	8
05	BR84	2	2(a)	12 to 18	8.2 to 15	2.2 to 3.3	0.82 to 1.5	8
06	CV41	2	2(b)	1.8 to 3.3	1.2 to 2.7	0.33 to 0.56	0.12 to 0.22	2
07	CH41	6	2(c)	1.8 to 3.3	1.2 to 2.7	0.33 to 0.56	0.12 to 0.22	2
08	CH41	6	2(d)	1.8 to 3.3	1.2 to 2.7	0.33 to 0.56	0.12 to 0.22	2
09	CH42	6	2(c)	3.9 to 6.8	3.3 to 5.6	0.68 to 1.2	0.27 to 0.47	4
10	CH42	6	2(d)	3.9 to 6.8	3.3 to 5.6	0.68 to 1.2	0.27 to 0.47	4
11	CH43	6	2(c)	8.2 to 10	6.8 to 8.2	1.5 to 1.8	0.56 to 0.68	6
12	CH43	6	2(d)	8.2 to 10	6.8 to 8.2	1.5 to 1.8	0.56 to 0.68	6
13	CH44	6	2(c)	12	10	2.2	0.82 to 1	8
14	CH44	6	2(d)	12	10	2.2	0.82 to 1	8
15	CV51	2	2(b)	3.9 to 5.6	2.2 to 3.9	0.68 to 1	0.27 to 0.39	3
16	CH51	8	2(c)	3.9 to 5.6	2.2 to 3.9	0.68 to 1	0.27 to 0.39	3
17	CH51	8	2(d)	3.9 to 5.6	2.2 to 3.9	0.68 to 1	0.27 to 0.39	3
18	CH52	8	2(c)	6.8 to 10	4.7 to 8.2	1.2 to 2.2	0.47 to 0.82	6
19	CH52	8	2(d)	6.8 to 10	4.7 to 8.2	1.2 to 2.2	0.47 to 0.82	6
20	CH53	8	2(c)	12 to 15	10 to 12	2.7 to 3.3	1 to 1.2	9
21	CH53	8	2(d)	12 to 15	10 to 12	2.7 to 3.3	1 to 1.2	9
22	CH54	8	2(c)	18 to 22	15	3.9	1.5	12
23	CH54	8	2(d)	18 to 22	15	3.9	1.5	12
24	CV61	2	2(b)	6.8 to 10	4.7 to 8.2	1 to 2.2	0.47 to 1	5
25	CH61	10	2(c)	6.8 to 10	4.7 to 8.2	1 to 2.2	0.47 to 1	5
26	CH61	10	2(d)	6.8 to 10	4.7 to 8.2	1 to 2.2	0.47 to 1	5
27	CH62	10	2(c)	12 to 22	10 to 15	2.7 to 4.7	1 to 1.8	10
28	CH62	10	2(d)	12 to 22	10 to 15	2.7 to 4.7	1 to 1.8	10
29	CH63	10	2(c)	27 to 33	18 to 22	5.6 to 6.8	2.2 to 2.7	15
30	CH63	10	2(d)	27 to 33	18 to 22	5.6 to 6.8	2.2 to 2.7	15
31	CH64	10	2(c)	39	27 to 33	8.2 to 10	3.3	20
32	CH64	10	2(d)	39	27 to 33	8.2 to 10	3.3	20
33	CV71	2	2(b)	12 to 18	8.2 to 15	2.2 to 3.3	0.82 to 1.5	8
34	CH71	14	2(c)	12 to 18	8.2 to 15	2.2 to 3.3	0.82 to 1.5	8
35	CH71	14	2(d)	12 to 18	8.2 to 15	2.2 to 3.3	0.82 to 1.5	8

**NOTES:** See Page 8.

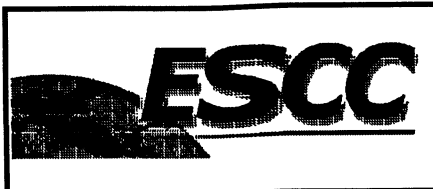

**TABLE 1(a) - TYPE VARIANTS AND RANGE OF COMPONENTS (CONTINUED)**

Variant	Case Size	Total Number of Leads	Figure	Capacitance Range ( $\mu\text{F}$ ) (E12)				Weight (g)
				50V	100V	200V	500V	
36	CH72	14	2(c)	22 to 39	18 to 27	3.9 to 6.8	1.8 to 3.3	16
37	CH72	14	2(d)	22 to 39	18 to 27	3.9 to 6.8	1.8 to 3.3	16
38	CH73	14	2(c)	47 to 56	33 to 39	8.2 to 10	3.9 to 4.7	24
39	CH73	14	2(d)	47 to 56	33 to 39	8.2 to 10	3.9 to 4.7	24
40	CH74	14	2(c)	68	47	12	5.6	32
41	CH74	14	2(d)	68	47	12	5.6	32
42	CV76	2	2(b)	12 to 18	8.2 to 15	2.2 to 3.3	0.82 to 1.5	8
43	CH76	12	2(c)	12 to 18	8.2 to 15	2.2 to 3.3	0.82 to 1.5	8
44	CH76	12	2(d)	12 to 18	8.2 to 15	2.2 to 3.3	0.82 to 1.5	8
45	CH77	12	2(c)	22 to 39	18 to 27	3.9 to 6.8	1.8 to 3.3	16
46	CH77	12	2(d)	22 to 39	18 to 27	3.9 to 6.8	1.8 to 3.3	16
47	CH78	12	2(c)	47 to 56	33 to 39	8.2 to 10	3.9 to 4.7	24
48	CH78	12	2(d)	47 to 56	33 to 39	8.2 to 10	3.9 to 4.7	24
49	CH79	12	2(c)	68	47	12	5.6	32
50	CH79	12	2(d)	68	47	12	5.6	32
51	CH81	28	2(c)	15 to 22	12 to 18	2.2 to 3.9	0.82 to 1.5	10
52	CH81	28	2(d)	15 to 22	12 to 18	2.2 to 3.9	0.82 to 1.5	10
53	CH82	28	2(c)	27 to 47	22 to 39	4.7 to 8.2	1.8 to 3.3	20
54	CH82	28	2(d)	27 to 47	22 to 39	4.7 to 8.2	1.8 to 3.3	20
55	CH83	28	2(c)	56 to 68	47 to 56	10 to 12	3.9 to 4.7	30
56	CH83	28	2(d)	56 to 68	47 to 56	10 to 12	3.9 to 4.7	30
57	CH84	28	2(c)	82	68	15	5.6	40
58	CH84	28	2(d)	82	68	15	5.6	40
59	CH86	28	2(c)	22 to 33	15 to 27	3.9 to 6.8	1.5 to 2.2	14
60	CH86	28	2(d)	22 to 33	15 to 27	3.9 to 6.8	1.5 to 2.2	14
61	CH87	28	2(c)	39 to 68	33 to 56	8.2 to 15	2.7 to 4.7	28
62	CH87	28	2(d)	39 to 68	33 to 56	8.2 to 15	2.7 to 4.7	28
63	CH88	28	2(c)	82 to 100	68 to 82	18 to 22	5.6 to 6.8	42
64	CH88	28	2(d)	82 to 100	68 to 82	18 to 22	5.6 to 6.8	42
65	CH89	28	2(c)	120	100	27	8.2	56
66	CH89	28	2(d)	120	100	27	8.2	56
67	CH91	28	2(c)	39 to 47	33 to 39	8.2 to 10	2.7 to 4.7	19
68	CH91	28	2(d)	39 to 47	33 to 39	8.2 to 10	2.7 to 4.7	19
69	CH92	28	2(c)	56 to 100	47 to 82	12 to 22	5.6 to 10	38
70	CH92	28	2(d)	56 to 100	47 to 82	12 to 22	5.6 to 10	38

**NOTES:** See Page 8.



**TABLE 1(a) - TYPE VARIANTS AND RANGE OF COMPONENTS (CONTINUED)**

Variant	Case Size	Total Number of Leads	Figure	Capacitance Range ( $\mu\text{F}$ ) (E12)				Weight (g)
				50V	100V	200V	500V	
71	CH93	28	2(c)	120 to 150	100 to 120	27 to 33	12 to 15	57
72	CH93	28	2(d)	120 to 150	100 to 120	27 to 33	12 to 15	57
73	CH94	28	2(c)	180	150	39	18	76
74	CH94	28	2(d)	180	150	39	18	76

**NOTES**

1. Tolerances of  $\pm 10\%$  and  $\pm 20\%$  are available.
2. For CH types, both D.I.L. and L style leads are available (see Figure 2).

**TABLE 1(b) - MAXIMUM RATINGS**

No.	Characteristics	Symbol	Limits		Unit	Remarks
			Min.	Max.		
1	Rated Voltage	$U_R$	See Table 1(a)		V	
2	Operating Temperature Range	$T_{op}$	- 55	+ 125	$^{\circ}\text{C}$	Without derating. $T_{amb}$
3	Storage Temperature Range	$T_{stg}$	- 55	+ 125	$^{\circ}\text{C}$	
4	Soldering Temperature	$T_{sol}$	-	+ 260	$^{\circ}\text{C}$	Note 1

**NOTES**

1. Duration 5 seconds maximum at a distance of not less than 1.5mm from the device body and the same lead shall not be resoldered until 3 minutes have elapsed.

**FIGURE 1 - PARAMETER DERATING INFORMATION**

Not applicable.

**FIGURE 2 - PHYSICAL DIMENSIONS**

FIGURE 2(a) - BR STYLE

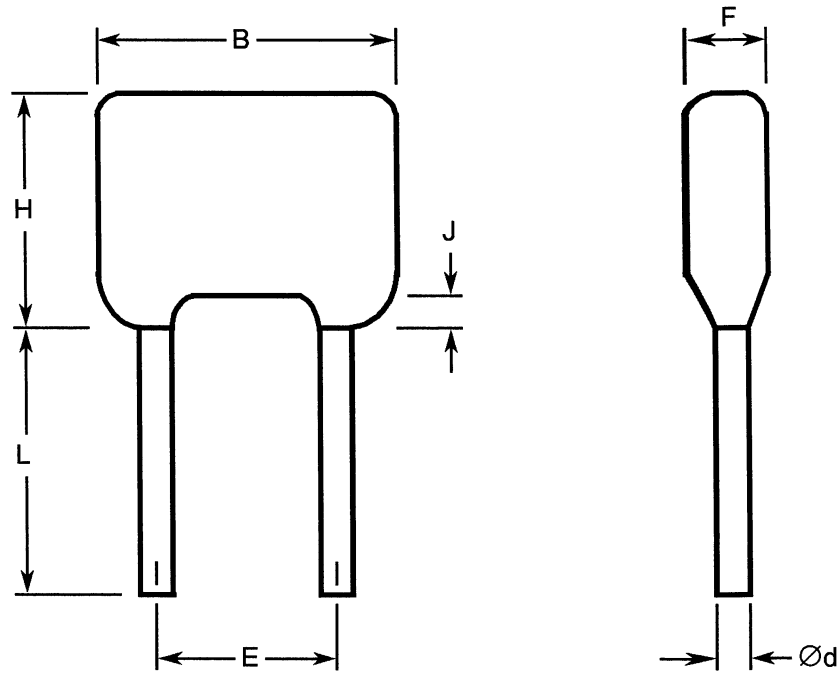

Variant	Case Size	Dimensions (mm)								
		B	Ød		E		F	H	J	L
		(max)	(min)	(max)	(min)	(max)	(max)	(max)	(max)	(min)
01	BR40	10.16	0.46	0.56	4.58	5.58	5	17	1.5	31.7
02	BR50	12.7	0.59	0.69	9.66	10.66	5.1	14.2	1.5	31.7
03	BR66	17.5	0.86	0.96	14.2	15.20	6.4	16.5	1.5	31.7
04	BR72	19.3	0.86	0.96	14.74	15.74	6.4	24	1.5	31.7
05	BR84	23.62	0.71	0.81	18.93	20.83	6.4	19.78	1.5	31.7

**FIGURE 2 - PHYSICAL DIMENSIONS (CONTINUED)**

FIGURE 2(b) - CV STYLE

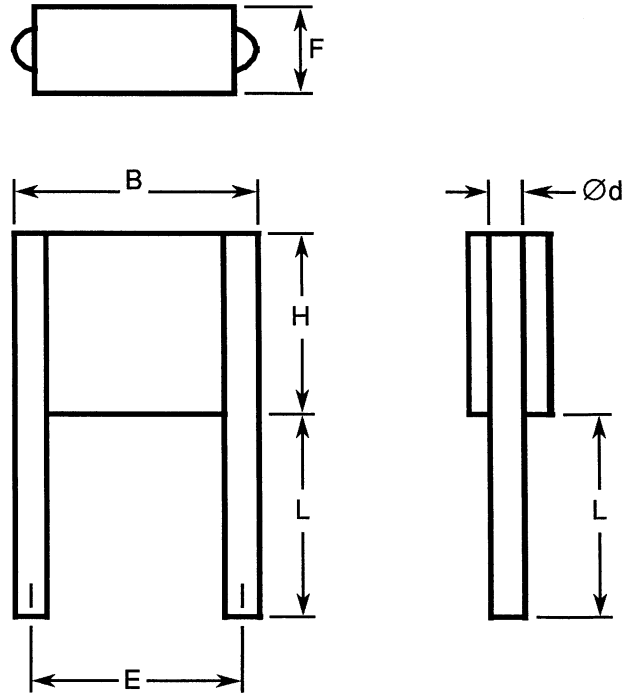

Variant	Case Size	Dimensions (mm)								
		B	Ød		E		F	H	L	
		(max)	(min)	(max)	(min)	(max)	(max)	(max)	(min)	(max)
06	CV41	10.6	0.65	0.75	7.7	8.7	3.8	8.7	22	28
15	CV51	11.9	0.85	0.95	9.66	10.66	3.8	10.7	22	28
24	CV61	16.5	0.85	0.95	14.74	15.74	3.8	13.6	22	28
33	CV71	17.8	0.85	0.95	14.74	15.74	3.8	21.6	22	28
42	CV76	22.7	0.85	0.95	20.4	22	3.8	16.6	22	28

**FIGURE 3 - FUNCTIONAL DIAGRAM**

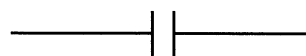

**FIGURE 2 - PHYSICAL DIMENSIONS (CONTINUED)**

**FIGURE 2(c) - CH STYLE, D.I.L.**

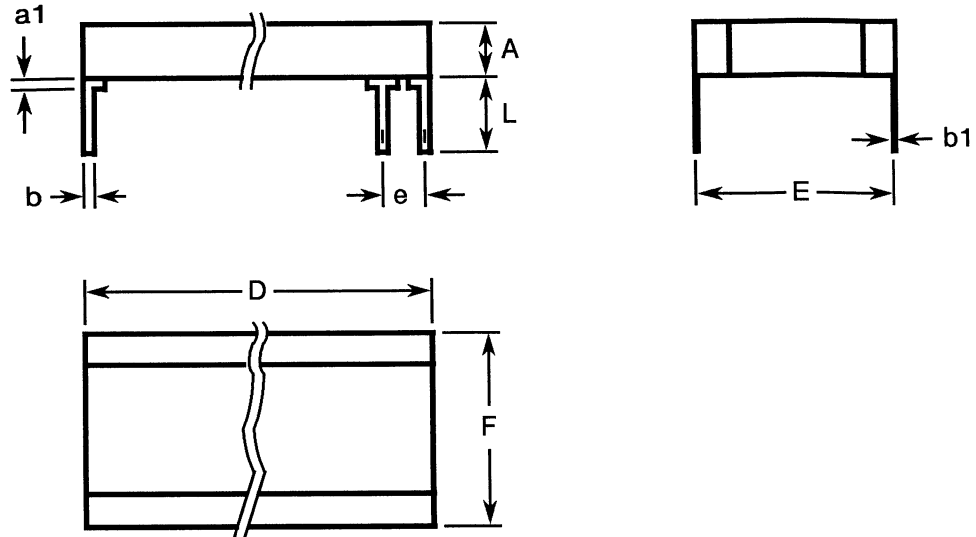

Variant	Case Size	Dimensions (mm)				
		A	D	E		F
		(max)	(max)	(min)	(max)	(max)
07	CH41	3.8	8.7	7.7	8.7	9.2
09	CH42	7.4	8.7	7.7	8.7	9.2
11	CH43	11.1	8.7	7.7	8.7	9.2
13	CH44	14.8	8.7	7.7	8.7	9.2
16	CH51	3.8	10.7	9.66	10.66	10.7
18	CH52	7.4	10.7	9.66	10.66	10.7
20	CH53	11.1	10.7	9.66	10.66	10.7
22	CH54	14.8	10.7	9.66	10.66	10.7
25	CH61	3.8	13.6	13.5	14.5	14.9
27	CH62	7.4	13.6	13.5	14.5	14.9
29	CH63	11.1	13.6	13.5	14.5	14.9
31	CH64	14.8	13.6	13.5	14.5	14.9
34	CH71	3.8	21.6	14.74	15.74	16.8
36	CH72	7.4	21.6	14.74	15.74	16.8
38	CH73	11.1	21.6	14.74	15.74	16.8
40	CH74	14.8	21.6	14.74	15.74	16.8
43	CH76	3.8	16.6	19.52	21.12	21.6
45	CH77	7.4	16.6	19.52	21.12	21.6
47	CH78	11.1	16.6	19.52	21.12	21.6
49	CH79	14.8	16.6	19.52	21.12	21.6

Variant	Case Size	Dimensions (mm)				
		A	D	E		F
		(max)	(max)	(min)	(max)	(max)
51	CH81	3.8	38.2	9.66	10.66	12
53	CH82	7.4	38.2	9.66	10.66	12
55	CH83	11.1	38.2	9.66	10.66	12
57	CH84	14.8	38.2	9.66	10.66	12
59	CH86	3.8	38.2	14.74	15.74	18.9
61	CH87	7.4	38.2	14.74	15.74	18.9
63	CH88	11.1	38.2	14.74	15.74	18.9
65	CH89	14.8	38.2	14.74	15.74	18.9
67	CH91	3.8	40.6	19.52	21.12	24
69	CH92	7.4	40.6	19.52	21.12	24
71	CH93	11.1	40.6	19.52	21.12	24
73	CH94	14.8	40.6	19.52	21.12	24

Symbol	Millimetres		Notes
	Min	Max	
a1	-	2	1
b	0.45	0.55	1
b1	0.204	0.304	1
e	2.49	2.59	2
L	12	14	1

**NOTES**

1. All leads.
2. Each space.

**FIGURE 2 - PHYSICAL DIMENSIONS (CONTINUED)**

**FIGURE 2(d) - CH STYLE, L**

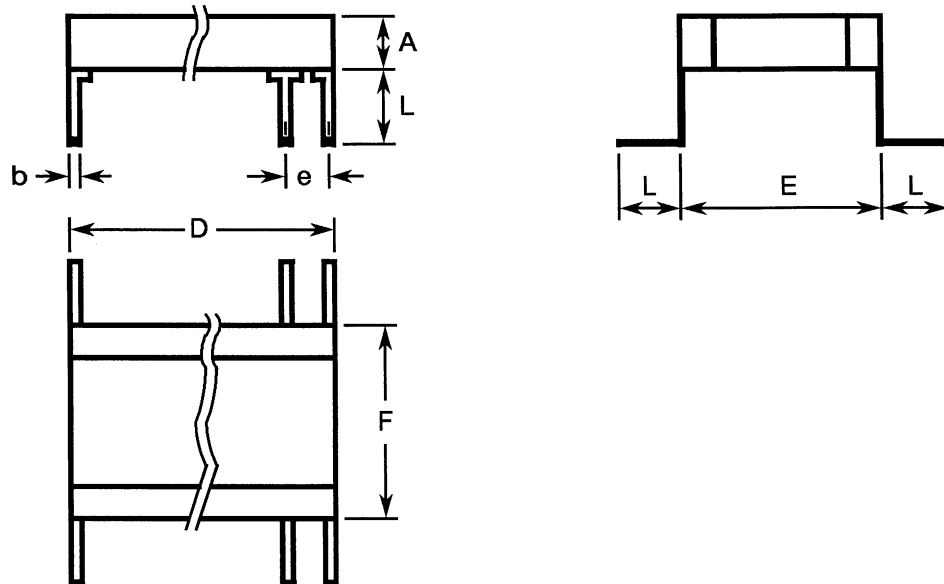

Variant	Case Size	Dimensions (mm)				
		A	D	E		F
		(max)	(max)	(min)	(max)	(max)
08	CH41	3.8	8.7	7.7	8.7	9.2
10	CH42	7.4	8.7	7.7	8.7	9.2
12	CH43	11.1	8.7	7.7	8.7	9.2
14	CH44	14.8	8.7	7.7	8.7	9.2
17	CH51	3.8	10.7	9.66	10.66	10.7
19	CH52	7.4	10.7	9.66	10.66	10.7
21	CH53	11.1	10.7	9.66	10.66	10.7
23	CH54	14.8	10.7	9.66	10.66	10.7
26	CH61	3.8	13.6	13.5	14.5	14.9
28	CH62	7.4	13.6	13.5	14.5	14.9
30	CH63	11.1	13.6	13.5	14.5	14.9
32	CH64	14.8	13.6	13.5	14.5	14.9
35	CH71	3.8	21.6	14.74	15.74	16.8
37	CH72	7.4	21.6	14.74	15.74	16.8
39	CH73	11.1	21.6	14.74	15.74	16.8
41	CH74	14.8	21.6	14.74	15.74	16.8
44	CH76	3.8	16.6	19.52	21.12	21.6
46	CH77	7.4	16.6	19.52	21.12	21.6
48	CH78	11.1	16.6	19.52	21.12	21.6
50	CH79	14.8	16.6	19.52	21.12	21.6

Variant	Case Size	Dimensions (mm)				
		A	D	E		F
		(max)	(max)	(min)	(max)	(max)
52	CH81	3.8	38.2	9.66	10.66	12
54	CH82	7.4	38.2	9.66	10.66	12
56	CH83	11.1	38.2	9.66	10.66	12
58	CH84	14.8	38.2	9.66	10.66	12
60	CH86	3.8	38.2	14.74	15.74	18.9
62	CH87	7.4	38.2	14.74	15.74	18.9
64	CH88	11.1	38.2	14.74	15.74	18.9
66	CH89	14.8	38.2	14.74	15.74	18.9
68	CH91	3.8	40.6	19.52	21.12	24
70	CH92	7.4	40.6	19.52	21.12	24
72	CH93	11.1	40.6	19.52	21.12	24
74	CH94	14.8	40.6	19.52	21.12	24

Symbol	Millimetres		Notes
	Min	Max	
b	0.45	0.55	1
e	2.49	2.59	2
L	2.04	3.04	1

**NOTES**

1. All leads.
2. Each space.

## 2. APPLICABLE DOCUMENTS

The following documents form part of this specification and shall be read in conjunction with it:-

- (a) ESCC Generic Specification No. 3001 for Capacitors, Fixed, Ceramic Dielectric, Types I and II.

## 3. TERMS, DEFINITIONS, ABBREVIATIONS, SYMBOLS AND UNITS

For the purpose of this specification, the terms, definitions, abbreviations, symbols and units specified in ESCC Basic Specification No. 21300 shall apply. In addition the following symbol is used:-

$V_T$  = Test Voltage.

## 4. REQUIREMENTS

### 4.1 GENERAL

The complete requirements for procurement of the capacitors specified herein are stated in this specification and ESCC Generic Specification No. 3001 for Capacitors, Fixed, Ceramic Dielectric, Types I and II. Deviations from the Generic Specification, applicable to this specification only, are listed in Para. 4.2.

Deviations from the applicable Generic Specification and this Detail Specification, formally agreed with specific Manufacturers on the basis that the alternative requirements are equivalent to the ESCC requirements and do not affect the components' reliability, are listed in the appendices attached to this specification.

### 4.2 DEVIATIONS FROM GENERIC SPECIFICATION

#### 4.2.1 Deviations from Special In-process Controls

- (a) Para. 5.2.3, Robustness of Terminations: Shall be replaced with a Lead Peel test as follows:-

1. Where necessary, bend the leads of the capacitor through 90° in the plane of the joint.
2. Apply a tensile force to the bend section of the lead until the joint peels.
3. The minimum peeling force shall be 8.9 Newtons for BR and CV Styles and 22.25 Newtons for CH Styles.

#### 4.2.2 Deviations from Final Production Tests (Chart II)

- (a) Para. 9.2.2, Pre-conditioning: Shall be performed.  
(b) Para. 9.5.1.4.1(b), Voltage Proof - Body Insulation: Not applicable for Variants 06 to 74.

#### 4.2.3 Deviations from Burn-in and Electrical Measurements (Chart III)

- (a) Para. 9.6, Radiographic Inspection: Not applicable for Variants 06 to 74.  
(b) Para. 9.5.1.4.1(b), Voltage Proof - Body Insulation: Not applicable for Variants 06 to 74.

#### 4.2.4 Deviations from Qualification Tests (Chart IV)

- (a) Para. 9.5.1.4.1(b), Voltage Proof - Body Insulation: Not applicable for Variants 06 to 74.

#### 4.2.5 Deviations from Lot Acceptance Tests (Chart V)

- (a) Para. 9.5.1.4.1(b), Voltage Proof - Body Insulation: Not applicable for Variants 06 to 74.



#### 4.3 MECHANICAL REQUIREMENTS

##### 4.3.1 Dimension Check

The dimensions of the capacitors specified herein shall be verified in accordance with the requirements set out in Para. 9.4 of ESCC Generic Specification No. 3001 and they shall conform to those shown in Figure 2 of this specification.

##### 4.3.2 Weight

The maximum weight of the capacitors specified herein shall be as scheduled in Table 1(a).

##### 4.3.3 Robustness of Terminations

The terminations of these devices are defined as 'rigid'.

#### 4.4 MATERIALS AND FINISHES

The materials and finishes shall be as specified herein. Where a definite material is not specified, a material which will enable the capacitors specified herein to meet the performance requirements of this specification shall be used. Acceptance or approval of any constituent material does not guarantee acceptance of the finished product.

##### 4.4.1 Encapsulation

Variants 01 to 05 shall be coated in epoxy resin.  
Variants 06 to 74 are classified as "non-insulated".

##### 4.4.2 Leads

- (a) For Variants 01 to 06, 15, 24, 33 and 42, the lead material shall be Type A with Type 3 finish in accordance with the requirements of ESCC Basic Specification No. 23500.
- (b) For Variants 07 to 14, 16 to 23, 25 to 32, 34 to 41 and 43 to 74, the lead material shall be Type N with Type 9 finish in accordance with the requirements of ESCC Basic Specification No. 23500.

#### 4.5 MARKING

##### 4.5.1 General

The marking of components delivered to this specification shall be in accordance with the requirements of ESCC Basic Specification No. 21700 and the following paragraphs. When the component is too small to accommodate all of the marking specified, as much as space permits shall be marked and the marking information, in full, shall accompany the component in its primary package.

The information to be marked and the order of precedence, shall be as follows:-

- (a) The ESCC Component Number.
- (b) Electrical Characteristics and Ratings.
- (c) Traceability Information.

4.5.2 The ESCC Component Number

The ESCC Component Number shall be constituted and marked as follows:-

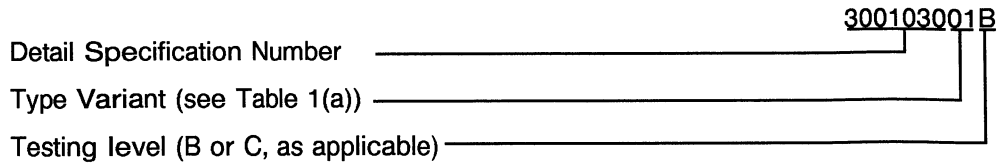

4.5.3 Electrical Characteristics and Ratings

The electrical characteristics and ratings to be marked in the following order of precedence are:-

- (a) Capacitance Value.
- (b) Tolerance.
- (c) Rated Voltage.

The information shall be constituted and marked as follows:-

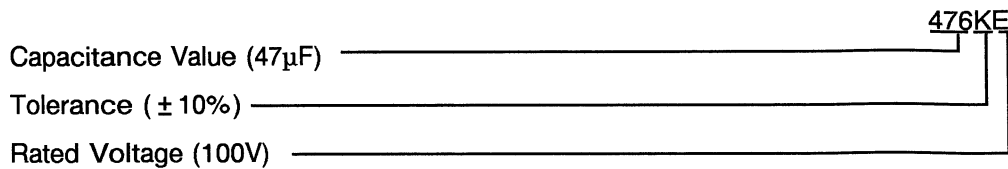

4.5.3.1 Capacitance Values

The capacitance values shall be expressed by means of the following codes. The unit quantity for marking shall be picofarads.

Capacitance Value	Code
XX	XX0
XX10 <sup>1</sup>	XX1
XX10 <sup>2</sup>	XX2
XX10 <sup>3</sup>	XX3
XX10 <sup>4</sup>	XX4
XX10 <sup>5</sup>	XX5
XX10 <sup>6</sup>	XX6

4.5.3.2 Tolerances

The tolerances on capacitance values shall be indicated by the code letters specified hereafter.

Tolerance (%)	Code Letter
± 10	K
± 20	M





#### 4.5.3.3 Rated Voltage

The rated voltage shall be indicated by the code letters specified hereafter.

Rated Voltage (V)	Code Letter
50	C
100	E
200	G
500	L

#### 4.5.4 Traceability Information

Traceability information shall be marked in accordance with the requirements of ESCC Basic Specification No. 21700.

#### 4.6 ELECTRICAL MEASUREMENTS

##### 4.6.1 Electrical Measurements at Room Temperature

The parameters to be measured at room temperature are scheduled in Table 2. Unless otherwise specified, measurements shall be performed at  $T_{amb} = +22 \pm 3$  °C.

##### 4.6.2 Electrical Measurements at High and Low Temperatures

The parameters to be measured at high and low temperatures are scheduled in Table 3. The measurements shall be performed at  $T_{amb} = +125(+0-5)$  and  $-55(+5-0)$  °C respectively.

##### 4.6.3 Circuits for Electrical Measurements

A circuit for use in performing the electrical measurements listed in Table 2 of this specification is shown in ESCC Generic Specification No. 3001.

#### 4.7 BURN-IN TESTS

##### 4.7.1 Parameter Drift Values

The parameter drift values applicable to burn-in are specified in Table 4 of this specification. Unless otherwise stated, measurements shall be performed at  $T_{amb} = +22 \pm 3$  °C.

The parameter drift values ( $\Delta$ ) applicable to the parameters scheduled shall not be exceeded. In addition to these drift value requirements for a given parameter, the appropriate limit value specified in Table 2 shall not be exceeded.

##### 4.7.2 Conditions for Burn-in

The requirements for burn-in are specified in Section 7 of ESCC Generic Specification No. 3001. The conditions for burn-in shall be as specified in Table 5 of this specification.

##### 4.7.3 Electrical Circuit for Burn-in (Figure 5)

Not applicable.



**TABLE 2 - ELECTRICAL MEASUREMENTS AT ROOM TEMPERATURE**

No.	Characteristics	Symbol	ESCC 3001 Test Conditions	Limits		Unit	Remarks
				Min	Max		
1	Capacitance	C	Para. 9.5.1.1	See Table 1(a)		μF	
2	Tangent of Loss Angle	Tgδ	Para. 9.5.1.2	-	250	10 <sup>-4</sup>	
3	Insulation Resistance	Ri × C	Para. 9.5.1.3	1000	-	sec	Note 1
4	Voltage Proof - Dielectric	VP	Para. 9.5.1.4	2.5U <sub>R</sub> for U <sub>R</sub> < 500V 2U <sub>R</sub> for U <sub>R</sub> = 500V		V	Note 1
5	Voltage Proof - Body Insulation	VP <sub>B</sub>	Para. 9.5.1.4	2.5U <sub>R</sub> for U <sub>R</sub> < 500V 2U <sub>R</sub> for U <sub>R</sub> = 500V		V	Note 2

**NOTES**

1. Variants 06 to 74 are classified as “non-insulated”.
2. Variants 01 to 05 only.

**TABLE 3 - ELECTRICAL MEASUREMENTS AT HIGH AND LOW TEMPERATURES**

No.	Characteristics	Symbol	ESCC 3001 Test Conditions	Limits		Unit	Remarks
				Min	Max		
3	Insulation Resistance at T <sub>amb</sub> = + 125 ± 3 °C	Ri × C	Para. 9.5.1.3	100	-	sec	Notes 1, 2 and 3
6(i)	Temperature Characteristic	TCC	Para. 9.17 V <sub>T</sub> = 0V V <sub>T</sub> = U <sub>R</sub>	- 20 - 50	+ 20 + 30	%	5 parts for each capacitance value Notes 3 and 5
6(ii)	Temperature Characteristic	TCC	Para. 9.17 V <sub>T</sub> = 0V V <sub>T</sub> = U <sub>R</sub>	- 20 - 50	+ 20 + 30	%	5 parts for each fired ceramic lot Notes 4 and 5

**NOTES**

1. Single sample: Inspection Level S3, AQL = 2.5%.
2. Variants 06 to 74 are classified as “non-insulated”.
3. Applicable to Level B only.
4. Applicable to Level C only.
5. If 1 failure occurs out of 5 parts, then test 100%. 1% rejects maximum allowed in the case of 100% testing.

**FIGURE 4 - CIRCUITS FOR ELECTRICAL MEASUREMENTS**

Not applicable.

**TABLE 4 - PARAMETER DRIFT VALUES**

No.	Characteristics	Symbol	Spec. and/or Test Method	Test Conditions	Change Limits ( $\Delta$ )	Unit
1	Capacitance Change	$\frac{\Delta C}{C}$	As per Table 2	As per Table 2	$\pm 10$	%

**TABLE 5 - CONDITIONS FOR BURN-IN AND OPERATING LIFE TESTS**

No.	Characteristic	Symbol	Condition	Unit
1	Ambient Temperature	$T_{amb}$	+ 125( + 0 - 3)	$^{\circ}C$
2	Test Voltage	$V_T$	$2U_R$ for $U_R < 500V$ $1.5U_R$ for $U_R = 500V$	V

**FIGURE 5 - ELECTRICAL CIRCUIT FOR BURN-IN AND OPERATING LIFE TESTS**

Not applicable.



- 4.8 ENVIRONMENTAL AND ENDURANCE TESTS (CHARTS IV AND V OF ESCC GENERIC SPECIFICATION NO. 3001)
- 4.8.1 Measurements and Inspections on Completion of Environmental Tests  
The parameters to be measured and inspections to be performed on completion of environmental tests are scheduled in Table 6. Unless otherwise stated, the measurements shall be performed at  $T_{amb} = +22 \pm 3$  °C.
- 4.8.2 Measurements and Inspections at Intermediate Points during Endurance Tests  
The parameters to be measured and inspections to be performed at intermediate points during endurance tests are scheduled in Table 6. Unless otherwise stated, the measurements shall be performed at  $T_{amb} = +22 \pm 3$  °C.
- 4.8.3 Measurements and Inspections on Completion of Endurance Tests  
The parameters to be measured and inspections to be performed on completion of endurance testing are scheduled in Table 6. Unless otherwise stated, the measurements shall be performed at  $T_{amb} = +22 \pm 3$  °C.
- 4.8.4 Conditions for Operating Life Tests (Part of Endurance Testing)  
The requirements for operating life testing are specified in Section 9 of ESCC Generic Specification No. 3001. The conditions for operating life testing shall be as specified in Table 5 for the burn-in test
- 4.8.5 Electrical Circuit for Operating Life Tests (Figure 5)  
Not applicable.



**TABLE 6 - MEASUREMENTS AND INSPECTIONS ON COMPLETION OF ENVIRONMENTAL TESTS AND AT INTERMEDIATE POINTS AND ON COMPLETION OF ENDURANCE TESTING**

NO.	ESCC GENERIC SPEC.NO. 3001		MEASUREMENTS AND INSPECTIONS		SYMBOL	LIMITS		UNIT
	ENVIRONMENTAL AND ENDURANCE TESTS (1)	TEST METHOD AND CONDITIONS	IDENTIFICATION	CONDITIONS		MIN.	MAX.	
01	Robustness of Terminations	Para. 9.7 and Para. 4.3.3 of this specification	Visual Examination	-	-	-	-	-
02	Resistance to Soldering Heat	Para. 9.8	<b>Initial Measurements</b> Capacitance	Table 2 Item 1	C	Table 2 Item 1		$\mu\text{F}$
			<b>Final Measurements</b> Capacitance Change Insulation Resistance	After a recovery period of $24 \pm 2$ hours Table 2 Item 1 Table 2 Item 3	$\Delta\text{C}/\text{C}$ $\text{Ri} \times \text{C}$	- 15   + 15 Table 2 Item 3	% sec	
03	Solderability	Para. 9.9	Visual Examination	-	-	-	-	-
04	Rapid Change of Temperature	Para. 9.10	<b>Initial Measurements</b> Capacitance	Table 2 Item 1	C	Table 2 Item 1		$\mu\text{F}$
			<b>Final Measurements</b> Visual Examination Capacitance Change Tangent of Loss Angle	After a recovery period of $24 \pm 2$ hours - Table 2 Item 1 Table 2 Item 2	- $\Delta\text{C}/\text{C}$ $\text{Tg}\delta$	-   - - 10   + 10 $2 \times$ Table 2 Item 2	- % $10^{-4}$	
05	Vibration	Para. 9.11	<b>During Last Cycle</b> Intermittent Contact	Para. 9.11.3 Open or Shorts	-	-	-	-
			<b>After Test</b> Visual Examination	-	-	-	-	-
06	Shock or Bump	Para. 9.12	Visual Examination	-	-	-	-	-
07	Climatic Sequence	Para. 9.13	<b>Initial Measurements</b> Capacitance	Table 2 Item 1	C	Table 2 Item 1		$\mu\text{F}$
			<b>Final Measurements</b>	After a recovery period of 1 to 24 hours	-	-	-	-
			External Visual Inspection	Para. 9.3 of ESCC 3001	-	-	-	-
			Capacitance Change	Table 2 Item 1	$\Delta\text{C}/\text{C}$	- 10   + 10	%	
			Tangent of Loss Angle	Table 2 Item 2	$\text{Tg}\delta$	$2 \times$ Table 2 Item 2	$10^{-4}$	
Insulation Resistance	Table 2 Item 3	$\text{Ri} \times \text{C}$	30	-	sec			
Voltage Proof - Body Insulation	Table 2 Item 5	$\text{VP}_\text{B}$	$2.5\text{U}_\text{R}$	-	V			

**NOTES**

1. The tests in this Table refer to either Chart IV or V and shall be used as applicable.