



Pages 1 to 17

## **TRANSISTORS, POWER, MOSFET, N-CHANNEL, RAD-HARD**

**BASED ON TYPE STRH100N6**

**ESCC Detail Specification No. 5205/022**

Issue 2	December 2011
---------	---------------



Document Custodian: European Space Agency - see <https://escies.org>

**LEGAL DISCLAIMER AND COPYRIGHT**

European Space Agency, Copyright © 2011. All rights reserved.

The European Space Agency disclaims any liability or responsibility, to any person or entity, with respect to any loss or damage caused, or alleged to be caused, directly or indirectly by the use and application of this ESCC publication.

This publication, without the prior permission of the European Space Agency and provided that it is not used for a commercial purpose, may be:

- copied in whole, in any medium, without alteration or modification.
- copied in part, in any medium, provided that the ESCC document identification, comprising the ESCC symbol, document number and document issue, is removed.

**DOCUMENTATION CHANGE NOTICE**

(Refer to <https://escies.org> for ESCC DCR content)

DCR No.	CHANGE DESCRIPTION
685	Specification upissued to incorporate technical changes per DCR.

**TABLE OF CONTENTS**

<b>1.</b>	<b><u>GENERAL</u></b>	<b>5</b>
1.1	Scope	5
1.2	Applicable Documents	5
1.3	Terms, Definitions, Abbreviations, Symbols and Units	5
1.4	The ESCC Component Number and Component Type Variants	5
1.4.1	The ESCC Component Number	5
1.4.2	Component Type Variants	5
1.5	Maximum Ratings	5
1.6	Handling Precautions	7
1.7	Physical Dimensions and Terminal Identification	8
1.8	Functional Diagram	9
1.9	Materials and Finishes	9
<b>2.</b>	<b><u>REQUIREMENTS</u></b>	<b>9</b>
2.1	General	9
2.1.1	Deviations from the Generic Specification	10
2.1.1.1	Deviations from Screening Tests - Chart F3	10
2.2	Wafer Lot Acceptance	10
2.3	Marking	10
2.4	Terminal Strength	10
2.5	Electrical Measurements at Room, High and Low Temperatures	10
2.5.1	Room Temperature Electrical Measurements	10
2.5.2	High and Low Temperatures Electrical Measurements	12
2.5.3	Notes to Room, High and Low Electrical Measurements	12
2.6	Parameter Drift Values	12
2.7	Intermediate and End-Point Electrical Measurements	13
2.8	High Temperature Reverse Bias Burn-in Conditions	13
2.9	High Temperature Forward Bias Burn-in Conditions	14
2.10	Operating Life Conditions	14
2.11	Total Dose Radiation Testing	14
2.11.1	Bias Conditions and Total Dose Level for Total Dose Radiation Testing	15
2.11.2	Electrical Measurements for Total Dose Radiation Testing	15
APPENDIX 'A'		16

**1. GENERAL**

**1.1 SCOPE**

This specification details the ratings, physical and electrical characteristics and test and inspection data for the component type variants and/or the range of components specified below. It supplements the requirements of, and shall be read in conjunction with, the ESCC Generic Specification listed under Applicable Documents.

**1.2 APPLICABLE DOCUMENTS**

The following documents form part of this specification and shall be read in conjunction with it:

- (a) ESCC Generic Specification No. 5000
- (b) MIL-STD-750, Test Methods and Procedures for Semiconductor Devices

**1.3 TERMS, DEFINITIONS, ABBREVIATIONS, SYMBOLS AND UNITS**

For the purpose of this specification, the terms, definitions, abbreviations, symbols and units specified in ESCC Basic Specification No. 21300 shall apply.

**1.4 THE ESCC COMPONENT NUMBER AND COMPONENT TYPE VARIANTS**

**1.4.1 The ESCC Component Number**

The ESCC Component Number shall be constituted as follows:

Example: 520502201F

- Detail Specification Reference: 5205022
- Component Type Variant Number: 01 (as required)
- Total Dose Radiation Level Letter: F (as required)

**1.4.2 Component Type Variants**

The component type variants applicable to this specification are as follows:

Variant Number	Based on Type	Case	Lead Material and Finish	Weight max g	Total Dose Radiation Level Letter
01	STRH100N6	TO-254AA	S14	10	F [50kRAD(Si)]
02	STRH100N6	TO-254AA	S4	10	F [50kRAD(Si)]

The lead material and finish shall be in accordance with the requirements of ESCC Basic Specification No. 23500.

Total dose radiation level letters are defined in ESCC Basic Specification No. 22900. If an alternative radiation test level is specified in the Purchase Order the letter shall be changed accordingly.

**1.5 MAXIMUM RATINGS**

The maximum ratings shall not be exceeded at any time during use or storage.

Maximum ratings shall only be exceeded during testing to the extent specified in this specification and when stipulated in Test Methods and Procedures of the ESCC Generic Specification.

Characteristics	Symbols	Maximum Ratings	Unit	Remarks
Drain-Source Voltage	$V_{DS}$	60	V	Over $T_{op}$ $V_{GS}=0V$ Note 2
Gate-Source Voltage	$V_{GS}$	$\pm 20$	V	Over $T_{op}$
Drain Current	$I_{DS}$	80	A	Continuous At $T_{case} \leq +25^{\circ}C$ Note 1
		50	A	Continuous At $T_{case} > +100^{\circ}C$ Note 1
Drain Current (Pulsed)	$I_{DM}$	320	A	Note 2
Power Dissipation	$P_{tot}$	176	W	At $T_{case} \leq +25^{\circ}C$ Note 1
Avalanche Energy (Single Pulse)	$E_{AS}$	954	mJ	$V_{DS}=40V$ $I_A=40A$ $T_j=+25\pm 3^{\circ}C$ $T_j=+110(+0 -5)^{\circ}C$
		280		
Avalanche Energy (Repetitive Pulse)	$E_{AR}$	24	mJ	$V_{DS}=40V$ $I_A=40A$ $f=100kHz$ , Duty Cycle = 10% $T_j=+25\pm 3^{\circ}C$ $T_j=+110(+0 -5)^{\circ}C$
		7.7		
Operating Temperature Range	$T_{op}$	-55 to +150	$^{\circ}C$	Note 3
Junction Temperature	$T_j$	+150	$^{\circ}C$	
Storage Temperature Range	$T_{stg}$	-55 to +150	$^{\circ}C$	Note 3
Soldering Temperature	$T_{sol}$	+260	$^{\circ}C$	Note 4
Thermal Resistance, Junction- to-Heat Sink	$R_{th(j-s)}$	0.71	$^{\circ}C/W$	Note 5
Thermal Resistance, Junction- to-Ambient	$R_{th(j-a)}$	48	$^{\circ}C/W$	Note 2

**NOTES:**

- $I_{DS}$  and  $P_{tot}$  ratings are in accordance with  $R_{th(j-s)}$ . The maximum theoretical  $I_D$  limit at  $T_{case} > +25^{\circ}C$  can be obtained by using the following formula ( $I_D$  is limited by the package and

device construction):

$$I_D = \sqrt{\frac{T_j(\text{max}) - T_{\text{case}}}{(R_{\text{th}(j-s)}) \times (r_{\text{DS(on)}} \text{ at } T_j(\text{max}))}}$$

Where  $(r_{\text{DS(on)}} \text{ at } T_j(\text{max})) = 30\text{m}\Omega$ .

For  $T_{\text{case}} > +25^\circ\text{C}$ , the Power Dissipation derates linearly to 0W at  $T_{\text{case}} = +150^\circ\text{C}$ .

- Safe Operating Area applies as follows:

Maximum Safe Operating Area

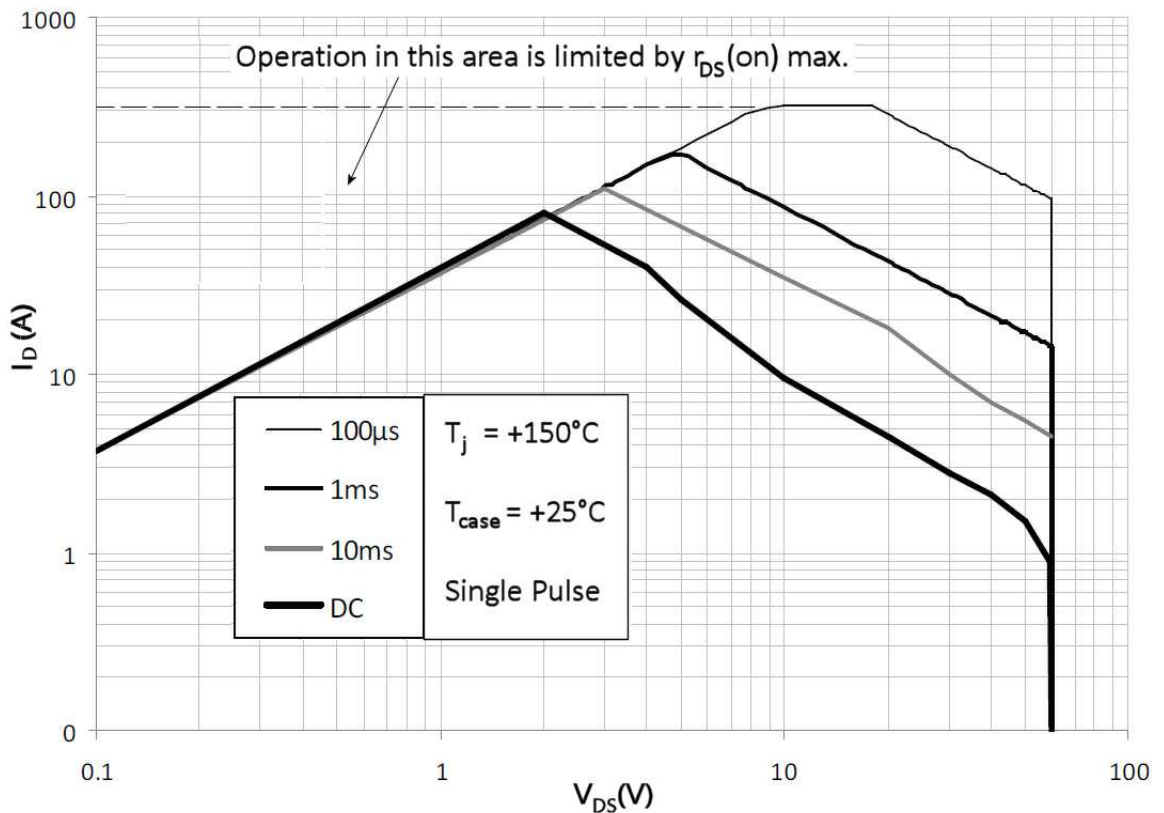

- For Variants with hot solder dip lead finish all testing and any handling performed at  $T_{\text{amb}} > +125^\circ\text{C}$  shall be carried out in a 100% inert atmosphere.
- Duration 10 seconds maximum at a distance of not less than 1.5mm from the device body and the same lead shall not be resoldered until 3 minutes have elapsed.
- Package is mounted on an infinite heatsink.

1.6

HANDLING PRECAUTIONS

The TO-254AA package contains Beryllium Oxide (BeO) and therefore it must not be ground, machined, sandblasted or subjected to any mechanical operation which will produce dust. The case must not be subjected to any chemical process (e.g. etching) which will produce fumes.

1.7

PHYSICAL DIMENSIONS AND TERMINAL IDENTIFICATION

Metal Flange Mount Package (TO-254AA) - 3 lead

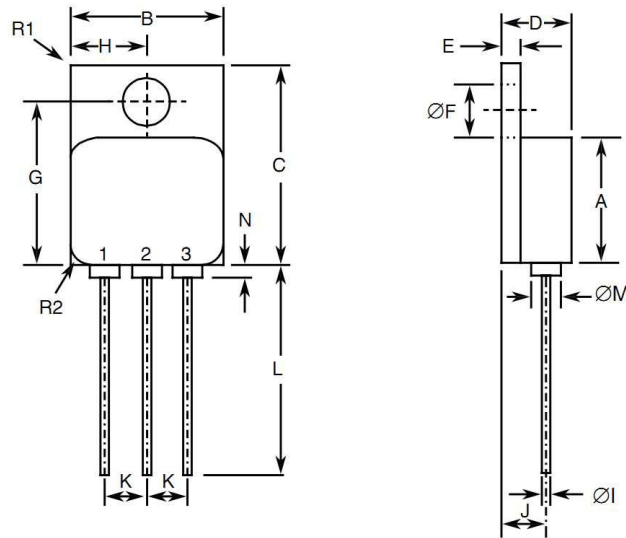

Symbols	Dimensions mm		Notes
	Min	Max	
A	13.59	13.84	
B	13.59	13.84	
C	20.07	20.32	
D	6.3	6.7	
E	1	1.35	
ØF	3.5	3.9	
G	16.89	17.4	
H	6.86 BSC		
ØI	0.89	1.14	2
J	3.81 BSC		
K	3.81 BSC		
L	12.95	14.5	
ØM	3.05 Typical		2
N	-	0.71	2
R1	-	1	3
R2	1.65 Typical		4

**NOTES:**

1. The terminal identification is specified by the components geometry. See Functional Diagram for the



- terminal connections.
- 2. 3 places.
- 3. Radius of heatsink flange corner, 4 places.
- 4. Radius of body corner, 4 places.

## 1.8 FUNCTIONAL DIAGRAM

Terminal 1: Drain  
Terminal 2: Source  
Terminal 3: Gate

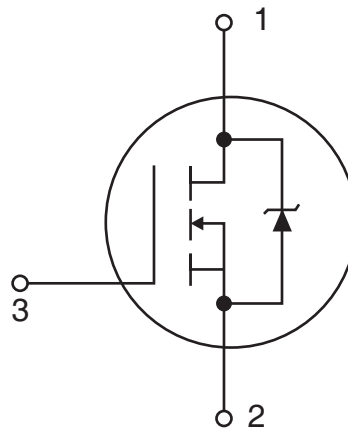

### **NOTES:**

1. The case is not connected to any lead.

## 1.9 MATERIALS AND FINISHES

Materials and finishes shall be as follows:

- a) Case  
The case shall be hermetically sealed and have a metal body. The leads pass through ceramic eyelets brazed into the frame and the lid shall be welded.
- b) Leads  
As specified in Component Type Variants.

## 2. REQUIREMENTS

### 2.1 GENERAL

The complete requirements for procurement of the components specified herein are as stated in this specification and the ESCC Generic Specification. Permitted deviations from the Generic Specification, applicable to this specification only, are listed below.

Permitted deviations from the Generic Specification and this Detail Specification, formally agreed with specific Manufacturers on the basis that the alternative requirements are equivalent to the ESCC requirement and do not affect the component's reliability, are listed in the appendices attached to this specification.

2.1.1 Deviations from the Generic Specification

2.1.1.1 *Deviations from Screening Tests - Chart F3*

- Verification of Safe Operating Area  
The Safe Operating Area shall be verified by performing the  $\Delta V_{SD}$  test specified in Room Temperature Electrical Measurements (Thermal Resistance, Junction-to-Heat Sink).
- A High Temperature Forward Bias test shall be performed instead of Power Burn-in.

2.2 WAFER LOT ACCEPTANCE

A SEM inspection shall be performed as specified in the ESCC Generic Specification.

2.3 MARKING

The marking shall be in accordance with the requirements of ESCC Basic Specification No. 21700 and as follows.

The information to be marked on the component shall be:

- (a) The ESCC Qualified Component symbol (for ESCC qualified components only).
- (b) The ESCC Component Number.
- (c) Traceability information.
- (d) Warning sign for Beryllium Oxide.

2.4 TERMINAL STRENGTH

The test conditions for terminal strength, tested as specified in the ESCC Generic Specification, shall be as follows:

Test Condition: A, tension, with an applied force of 10N for a duration of 10s.

2.5 ELECTRICAL MEASUREMENTS AT ROOM, HIGH AND LOW TEMPERATURES

Electrical measurements shall be performed at room, high and low temperatures. Consolidated notes are given after the tables.

2.5.1 Room Temperature Electrical Measurements

Unless otherwise specified, the measurements shall be performed at  $T_{amb}=+22 \pm 3^{\circ}C$ .

Characteristics	Symbols	MIL-STD-750 Test Method	Test Conditions	Limits		Units
				Min	Max	
Drain-to-Source Breakdown Voltage	$V_{(BR)DSS}$	3407	$V_{GS}=0V$ , $I_D=1mA$ Bias condition C	60	-	V
Gate-to-Source Leakage Current 1	$I_{GSS1}$	3411	$V_{GS}=20V$ , $V_{DS}=0V$ Bias condition C	-	100	nA

Characteristics	Symbols	MIL-STD-750 Test Method	Test Conditions	Limits		Units
				Min	Max	
Gate-to-Source Leakage Current 2	$I_{GSS2}$	3411	$V_{GS}=-20V$ , $V_{DS}=0V$ Bias condition C	-100	-	nA
Drain Current	$I_{DSS}$	3413	$V_{DS}=48V$ , $V_{GS}=0V$ Bias condition C	-	10	$\mu A$
Gate-to-Source Threshold Voltage	$V_{GS(th)}$	3403	$V_{DS} \geq V_{GS}$ $I_D=1mA$	2	4.5	V
Static Drain-to- Source On Resistance	$r_{DS(on)}$	3421	$V_{GS}=12V$ , $I_D=40A$ Note 1	-	13.5	m $\Omega$
Source-to-Drain Diode Forward Voltage	$V_{SD}$	4011	$V_{GS}=0V$ , $I_{SD}=80A$ Note 1	-	1.5	V
Thermal Resistance, Junction-to-Heat Sink	$R_{th(j-s)}$	3161	Note 2	-	0.71	$^{\circ}C/W$
Input Capacitance	$C_{iss}$	3431	$V_{GS}=0V$ , $V_{DS}=25V$ $f=1MHz$	3916	5874	pF
Output Capacitance	$C_{oss}$	3453		864	1296	pF
Reverse Transfer Capacitance	$C_{rss}$	3433		325	488	pF
Total Gate Charge	$Q_g$	3471	$V_{GS}=12V$ , $V_{DS}=30V$ $I_D=80A$	107	161	nC
Gate-to-Source Charge	$Q_{gs}$			22	43	nC
Gate-to-Drain Charge	$Q_{gd}$			34	59	nC
Turn-on Delay Time	$t_{d(on)}$	3472	$V_{GS}=12V$ , $V_{DS}=30V$ $I_D=40A$ $R_G=4.7\Omega$	22	34	ns
Rise Time	$t_r$			90	140	ns
Turn-off Delay Time	$t_{d(off)}$			62	110	ns
Fall Time	$t_f$			45	93	ns
Reverse Recovery Time	$t_{rr}$	3473	$V_{DS}=48V$ , $I_{SD}=80A$ $di/dt=100A/\mu s$ $T_j=+25 \pm 3^{\circ}C$	307	461	ns

2.5.2 High and Low Temperatures Electrical Measurements

Characteristics	Symbols	MIL-STD-750 Test Method	Test Conditions Note 3	Limits		Units
				Min	Max	
Gate-to-Source Leakage Current 1	$I_{GSS1}$	3411	$V_{GS}=20V$ , $V_{DS}=0V$ Bias condition C $T_{case}=+125(+0-5)^{\circ}C$	-	200	nA
Gate-to-Source Leakage Current 2	$I_{GSS2}$	3411	$V_{GS}=-20V$ , $V_{DS}=0V$ Bias condition C $T_{case}=+125(+0-5)^{\circ}C$	-200	-	nA
Drain Current	$I_{DSS}$	3413	$V_{DS}=48V$ , $V_{GS}=0V$ Bias condition C $T_{case}=+125(+0-5)^{\circ}C$	-	100	$\mu A$
Gate-to-Source Threshold Voltage	$V_{GS(th)}$	3403	$V_{DS} \geq V_{GS}$ $I_D=1mA$ $T_{case}=+125(+0-5)^{\circ}C$	1.6	3.5	V
			$V_{DS} \geq V_{GS}$ $I_D=1mA$ $T_{case}=-55(+5-0)^{\circ}C$	2.2	5	V
Static Drain-to-Source On Resistance	$r_{DS(on)}$	3421	$V_{GS}=12V$ , $I_D=40A$ $T_{case}=+125(+0-5)^{\circ}C$ Note 1	-	24	m $\Omega$
Source-to-Drain Diode Forward Voltage	$V_{SD}$	4011	$V_{GS}=0V$ , $I_{SD}=80A$ $T_{case}=+125(+0-5)^{\circ}C$ Note 1	-	1.275	V

2.5.3 Notes to Room, High and Low Electrical Measurements

- Pulsed measurement: Pulse Width  $\leq 680\mu s$ , Duty Cycle  $\leq 2\%$ .
- The  $R_{th(j-s)}$  limit is guaranteed by performing a  $\Delta V_{SD}$  (go-no-go) test. The following test conditions and limits shall apply:
  - $V_{DS} = 5V$
  - $I_D = 32A$
  - $I_{cal} = 29mA$
  - $t_{pulse} = 20ms$
  - $t_{cal} = 50\mu s$

$V_{SD} = 60mV$  minimum, 200mV maximum
- Read and record measurements shall be performed on a sample of 5 components with 0 failures allowed. Alternatively a 100% inspection may be performed.

2.6 PARAMETER DRIFT VALUES

Unless otherwise specified, the measurements shall be performed at  $T_{amb}=+22 \pm 3^{\circ}C$ .

The test methods and test conditions shall be as per the corresponding test defined in Room Temperature Electrical Measurements.

The drift values ( $\Delta$ ) shall not be exceeded for each characteristic specified. The corresponding absolute limit values for each characteristic shall not be exceeded.

Characteristics	Symbols	Limits			Units
		Drift Value $\Delta$	Absolute		
			Min	Max	
Gate-to-Source Leakage Current 1	$I_{GSS1}$	$\pm 50$ or (1) $\pm 100\%$	-	100	nA
Gate-to-Source Leakage Current 2	$I_{GSS2}$	$\pm 50$ or (1) $\pm 100\%$	-100	-	nA
Drain Current	$I_{DSS}$	$\pm 4$ or (1) $\pm 100\%$	-	10	$\mu A$
Gate-to-Source Threshold Voltage	$V_{GS(th)}$	$\pm 5\%$	2	4.5	V
Static Drain-to-Source On Resistance	$r_{DS(on)}$	$\pm 10\%$	-	13.5	$m\Omega$

**NOTES:**

1. Whichever is the greater referred to the initial value.

2.7 **INTERMEDIATE AND END-POINT ELECTRICAL MEASUREMENTS**

Unless otherwise specified, the measurements shall be performed at  $T_{amb} = +22 \pm 3^\circ C$ .

The test methods and test conditions shall be as per the corresponding test defined in Room Temperature Electrical Measurements.

The limit values for each characteristic shall not be exceeded.

Characteristics	Symbols	Limits		Units
		Min	Max	
Drain Current	$I_{DSS}$	-	10	$\mu A$
Gate-to-Source Threshold Voltage	$V_{GS(th)}$	2	4.5	V
Static Drain-to-Source On Resistance	$r_{DS(on)}$	-	13.5	$m\Omega$

2.8 **HIGH TEMPERATURE REVERSE BIAS BURN-IN CONDITIONS**

HTRB Burn-in shall be performed in accordance with MIL-STD-750, Test Method 1042, Test Condition A with the following conditions:

Characteristics	Symbols	Test Conditions	Units
Ambient Temperature	$T_{amb}$	+150(+0-5)	°C
Drain-to-Source Voltage	$V_{DS}$	48	V
Gate-to-Source Voltage	$V_{GS}$	0	V
Duration	t	240 minimum	Hours

2.9 HIGH TEMPERATURE FORWARD BIAS BURN-IN CONDITIONS

HTFB Burn-in shall be performed in accordance with MIL-STD-750, Test Method 1042, Test Condition B with the following conditions:

Characteristics	Symbols	Test Conditions	Units
Ambient Temperature	$T_{amb}$	+150(+0-5)	°C
Drain-to-Source Voltage	$V_{DS}$	0	V
Gate-to-Source Voltage	$V_{GS}$	16	V
Duration	t	48 minimum	Hours

2.10 OPERATING LIFE CONDITIONS

Operating Life shall consist of High Temperature Reverse Bias in accordance with MIL-STD-750, Test Method 1042, Test Condition A, followed by High Temperature Forward Bias in accordance with MIL-STD-750, Test Method 1042, Test Condition B. The test conditions are as follows:

High Temperature Reverse Bias Conditions

Characteristics	Symbols	Test Conditions	Units
Ambient Temperature	$T_{amb}$	+150(+0-5)	°C
Drain-to-Source Voltage	$V_{DS}$	48	V
Gate-to-Source Voltage	$V_{GS}$	0	V
Duration	t	1000 minimum	Hours

High Temperature Forward Bias Conditions

Characteristics	Symbols	Test Conditions	Units
Ambient Temperature	$T_{amb}$	+150(+0-5)	°C
Drain-to-Source Voltage	$V_{DS}$	0	V
Gate-to-Source Voltage	$V_{GS}$	16	V
Duration	t	1000 minimum	Hours

2.11 TOTAL DOSE RADIATION TESTING

All lots shall be irradiated in accordance with ESCC Basic Specification No. 22900, standard dose rate (window 1: 3.6kRAD to 36kRAD per hour).

2.11.1 Bias Conditions and Total Dose Level for Total Dose Radiation Testing

The following bias condition (worst-case) shall be used for Total Dose Radiation Testing at  $T_{amb}=22\pm3^{\circ}C$ :

With  $V_{GS}$  bias = +15V and  $V_{DS}$  = 0V during irradiation.

The total dose level applied shall be as specified in the component type variant information herein or in the Purchase Order.

2.11.2 Electrical Measurements for Total Dose Radiation Testing

Prior to irradiation testing the devices shall have successfully met Room Temperature Electrical Measurements specified herein.

Unless otherwise stated the measurements shall be performed at  $T_{amb} = 22\pm3^{\circ}C$ .

Unless otherwise specified the test methods and test conditions shall be as per the corresponding test defined in Room Temperature Electrical Measurements.

The parameters to be measured during irradiation testing, on completion of irradiation testing, after 24 hours anneal at Room Temperature and after 168 hours anneal at  $+100\pm3^{\circ}C$  are shown below.

Characteristics	Symbols	Limits			Units
		Drift Values ( $\Delta$ )	Absolute		
			Min	Max	
Drain-to-Source Voltage Note 1	$V_{DSS}$	-15% Note 2	N/A		V
Gate-to-Source Leakage Current 1	$I_{GSS1}$	+1.5	-	100	nA
Gate-to-Source Leakage Current 2	$I_{GSS2}$	-1.5	-100	-	nA
Drain Current	$I_{DSS}$	+10	-	10	$\mu A$
Gate-to-Source Threshold Voltage	$V_{GS(th)}$	-60% / +25%	2	4.5	V
Static Drain-to-Source On Resistance	$r_{DS(on)}$	$\pm 15\%$	-	13.5	m $\Omega$
Source-to-Drain Diode Forward Voltage	$V_{SD}$	$\pm 5\%$	-	1.5	V
Total Gate Charge	$Q_g$	-5% / +50%	107	161	nC
Gate-to-Source Charge	$Q_{gs}$	$\pm 35\%$	22	33	nC
Gate-to-Drain Charge	$Q_{gd}$	-5% / +110%	39	59	nC

**NOTES:**

1. Drain-to-Source Voltage measurements shall be made in accordance with MIL-STD-750, Test Method 3405, with  $V_{GS} = 0V$  and  $I_D = 1mA$ .
2. Referred to an initial Drain-to-Source Voltage measurement made prior to the commencement of Total Dose Radiation Testing.

**APPENDIX 'A'**

**AGREED DEVIATIONS FOR STMICROELECTRONICS (F)**

ITEMS AFFECTED	DESCRIPTION OF DEVIATIONS
Deviations from Room Temperature Electrical Measurements	<p>The AC characteristics <math>C_{iss}</math>, <math>C_{oss}</math>, <math>C_{rss}</math>, <math>Q_g</math>, <math>Q_{gs}</math>, <math>Q_{gd}</math>, <math>t_{d(on)}</math>, <math>t_r</math>, <math>t_{d(off)}</math>, <math>t_f</math> and <math>t_{rr}</math> may be considered guaranteed but not tested if successful pilot lot testing has been performed on the wafer lot in accordance with STMicroelectronics procedure 8212069, which includes AC (<math>C_{iss}</math>, <math>C_{oss}</math>, <math>C_{rss}</math>, <math>Q_g</math>, <math>Q_{gs}</math>, <math>Q_{gd}</math>, <math>t_{d(on)}</math>, <math>t_r</math>, <math>t_{d(off)}</math>, <math>t_f</math> and <math>t_{rr}</math>) characteristic measurements per the Detail Specification.</p> <p>A summary of the pilot lot testing shall be provided if required by the Purchase Order.</p>
Deviations from Electrical Measurements for Total Dose Radiation Testing	<p>The AC characteristics <math>Q_g</math>, <math>Q_{gs}</math> and <math>Q_{gd}</math> need not be measured because they are guaranteed by the results obtained by STMicroelectronics during the evaluation phase which proved these characteristics are directly correlated to the <math>V_{GS(th)}</math> shift.</p>
Deviations from Screening Tests - Chart F3	<p>Solderability is not applicable unless specifically stipulated in the Purchase Order.</p>

**ADDITIONAL DATA - STMICROELECTRONICS (F)**

(a) Derating for Space Application

These components are susceptible to Single Event Gate Rupture if operated in a space environment unless the following derating is applied. The derating for space applications was originally obtained on STRH100N6 devices under the following test conditions. The testing was performed in a vacuum at UCL (Louvain-la-Neuve, Belgium):

- Ion used = Kr
- LET = 32 (MeV / (mg/cm<sup>2</sup>))
- Energy = 768 MeV
- Range = 94 μm

- $V_{DS} \leq 60V$  when  $V_{GS} = 0V$ ,
- $V_{DS} \leq 48V$  when  $V_{GS} = -2V$ ,
- $V_{DS} \leq 15V$  when  $V_{GS} = -15V$ .



### Single Event Effect Safe Operating Area

