



**DIODES, MICROWAVE, SILICON, PIN,  
BASED ON TYPE BXY42 - MESA  
ESCC Detail Specification No. 5513/017**

**ISSUE 1  
October 2002**



|  |                           |  |                    |
|--|---------------------------|--|--------------------|
|  | ESCC Detail Specification |  | PAGE ii<br>ISSUE 1 |
|--|---------------------------|--|--------------------|

### **LEGAL DISCLAIMER AND COPYRIGHT**

European Space Agency, Copyright © 2002. All rights reserved.

The European Space Agency disclaims any liability or responsibility, to any person or entity, with respect to any loss or damage caused, or alleged to be caused, directly or indirectly by the use and application of this ESCC publication.

This publication, without the prior permission of the European Space Agency and provided that it is not used for a commercial purpose, may be:

- copied in whole in any medium without alteration or modification.
- copied in part, in any medium, provided that the ESCC document identification, comprising the ESCC symbol, document number and document issue, is removed.



**european space agency  
agence spatiale européenne**

Pages 1 to 20

**DIODES, MICROWAVE, SILICON, PIN,**

**BASED ON TYPE BXY42 - MESA**

**ESA/SCC Detail Specification No. 5513/017**

**SCC**

**space components  
coordination group**

| Issue/Rev. | Date      | Approved by        |                                       |
|------------|-----------|--------------------|---------------------------------------|
|            |           | SCCG Chairman      | ESA Director General<br>or his Deputy |
| Issue 2    | June 1994 | <i>[Signature]</i> | <i>[Signature]</i>                    |
|            |           |                    |                                       |
|            |           |                    |                                       |
|            |           |                    |                                       |



**DOCUMENTATION CHANGE NOTICE**

| Rev. Letter | Rev. Date | Reference   | CHANGE Item  | Approved DCR No. |
|-------------|-----------|---|--|------------------|
|             |           | This issued supersedes Issue 1 and incorporates all the modifications defined in the following DCRs:- |  |                  |
|             |           | Cover Page  | : In title, 'Planar' replaced by 'Mesa'                          | 221170           |
|             |           | DCN   |  | None             |
|             |           | Para. 1.1   | : 'Planar' replaced by 'Mesa'                                    | 221170           |
|             |           | Table of Contents   | : Amended as relevant  | None             |
|             |           | Paras. 4.2.2 to 4.2.5   | : Deviations amended   | 221170           |
|             |           | Para. 4.6.2   | : T <sub>amb</sub> changed to +125°C                             | 221170           |
|             |           | Table 3   | : Max. limit of I <sub>R2</sub> changed to 100nA                 | 221170           |
|             |           | Table 4   | : In characteristics of item 2, '1' changed to '2'               | 221170           |
|             |           | Table 5(b)  | : Characteristics, symbol and conditions of item 1 amended       | 221170           |
|             |           | Figure 5(a)   | : Value of R specified   | 221170           |
|             |           | Figure 5(b)   | : Value of R specified   | 221170           |
|             |           | Table 7   | : Item R <sub>F1</sub> re-specified (change limits, Note, graph) | 221170           |

**TABLE OF CONTENTS**

|   | <u>Page</u> |
|---|-------------|
| <b>1. <u>GENERAL</u></b>  | <b>5</b>    |
| 1.1 Scope   | 5           |
| 1.2 Type Variants   | 5           |
| 1.3 Maximum Ratings   | 5           |
| 1.4 Parameter Derating Information  | 5           |
| 1.5 Physical Dimensions   | 5           |
| 1.6 Functional Diagram  | 5           |
| 1.7 Handling Precautions  | 5           |
| <b>2. <u>APPLICABLE DOCUMENTS</u></b>   | <b>5</b>    |
| <b>3. <u>TERMS, DEFINITIONS, ABBREVIATIONS, SYMBOLS AND UNITS</u></b>                     | <b>5</b>    |
| <b>4. <u>REQUIREMENTS</u></b>   | <b>10</b>   |
| 4.1 General   | 10          |
| 4.2 Deviations from Generic Specification   | 10          |
| 4.2.1 Deviations from Special In-process Controls   | 10          |
| 4.2.2 Deviations from Final Production Tests  | 10          |
| 4.2.3 Deviations from Burn-in and Electrical Measurements                                 | 10          |
| 4.2.4 Deviations from Qualification Tests   | 11          |
| 4.2.5 Deviations from Lot Acceptance Tests  | 11          |
| 4.3 Mechanical and Environmental Requirements   | 11          |
| 4.3.1 Dimension Check   | 11          |
| 4.3.2 Weight  | 11          |
| 4.3.3 Terminal Strength   | 11          |
| 4.4 Materials and Finishes  | 11          |
| 4.4.1 Case  | 11          |
| 4.4.2 Terminal and Lead Material and Finish   | 12          |
| 4.5 Marking   | 12          |
| 4.5.1 General   | 12          |
| 4.5.2 Cathode Identification  | 12          |
| 4.5.3 The SCC Component Number  | 12          |
| 4.5.4 Traceability Information  | 12          |
| 4.6 Electrical Measurements   | 12          |
| 4.6.1 Electrical Measurements at Room Temperature   | 12          |
| 4.6.2 Electrical Measurements at High and Low Temperatures                                | 12          |
| 4.6.3 Circuits for Electrical Measurements  | 13          |
| 4.7 Burn-in Tests   | 13          |
| 4.7.1 Parameter Drift Values  | 13          |
| 4.7.2 Conditions for High Temperature Reverse Bias Burn-in                                | 13          |
| 4.7.3 Electrical Circuit for High Temperature Reverse Bias Burn-in                        | 13          |
| 4.7.4 Conditions for Power Burn-in  | 13          |
| 4.7.5 Electrical Circuit for Power Burn-in  | 13          |
| 4.8 Environmental and Endurance Tests   | 18          |
| 4.8.1 Electrical Measurements on Completion of Environmental Tests                        | 18          |
| 4.8.2 Electrical Measurements at Intermediate Points and on Completion of Endurance Tests | 18          |
| 4.8.3 Conditions for Operating Life Tests   | 18          |
| 4.8.4 Electrical Circuits for Operating Life Tests  | 18          |
| 4.9 Total Dose Irradiation Testing  | 18          |
| 4.9.1 Application   | 18          |
| 4.9.2 Bias Conditions   | 18          |



|       |                         |                   |
|-------|-------------------------|-------------------|
| 4.9.3 | Electrical Measurements | <u>Page</u><br>18 |
| 4.10  | Special Testing         | 18                |

### **TABLES**

|      |   |    |
|------|---|----|
| 1(a) | Type Variants   | 6  |
| 1(b) | Maximum Ratings   | 6  |
| 2    | Electrical Measurements at Room Temperature - D.C. Parameters                         | 14 |
|      | Electrical Measurements at Room Temperature - A.C. Parameters                         | 14 |
| 3    | Electrical Measurements at High and Low Temperatures                                  | 14 |
| 4    | Parameter Drift Values  | 16 |
| 5(a) | Conditions for High Temperature Reverse Bias Burn-in                                  | 16 |
| 5(b) | Conditions for Power Burn-in and Operating Life Tests                                 | 16 |
| 6    | Electrical Measurements at Intermediate Points and on Completion of Endurance Testing | 19 |
| 7    | Electrical Measurements During and on Completion of Irradiation Testing               | 20 |

### **FIGURES**

|      |   |    |
|------|---|----|
| 1    | Parameter Derating Information                                | 7  |
| 2    | Physical Dimensions   | 8  |
| 3    | Functional Diagram  | 9  |
| 4    | Test Circuit for Minority Carrier Lifetime Measurement        | 15 |
| 5(a) | Electrical Circuit for High Temperature Reverse Bias Burn-in  | 17 |
| 5(b) | Electrical Circuit for Power Burn-in and Operating Life Tests | 17 |
| 6    | Bias Conditions for Irradiation Testing                       | 19 |

### **APPENDICES (Applicable to specific Manufacturers only)**

None.

**1. GENERAL****1.1 SCOPE**

This specification details the ratings, physical and electrical characteristics, test and inspection data for a Diode, Microwave, Silicon, PIN, based on Type BXY42 - Mesa. It shall be read in conjunction with ESA/SCC Generic Specification No. 5010, the requirements of which are supplemented herein.

**1.2 TYPE VARIANTS**

Variants of the basic diodes specified herein, which are also covered by this specification, are given in Table 1(a).

**1.3 MAXIMUM RATINGS**

The maximum ratings, which shall not be exceeded at any time during use or storage, applicable to the diodes specified herein, are as scheduled in Table 1(b).

**1.4 PARAMETER DERATING INFORMATION**

The derating information applicable to the diodes specified herein, is shown in Figure 1.

**1.5 PHYSICAL DIMENSIONS**

The physical dimensions of the diodes specified herein are shown in Figure 2.

**1.6 FUNCTIONAL DIAGRAM**

The functional diagram, showing lead identification, of the diodes specified herein, is shown in Figure 3.

**1.7 HANDLING PRECAUTIONS**

These devices are susceptible to damage by electrostatic discharge. Therefore, suitable precautions shall be employed for protection during all phases of manufacture, testing, packaging, shipment and any handling.

These components are Categorised as Class 1 with a Minimum Critical Path Failure Voltage of 1000V.

**2. APPLICABLE DOCUMENTS**

The following documents form part of this specification and shall be read in conjunction with it:-

- (a) ESA/SCC Generic Specification No. 5010 for Discrete Microwave Semiconductor Components.
- (b) MIL-STD-750, Test Methods and Procedures for Semiconductor Devices.

**3. TERMS, DEFINITIONS, ABBREVIATIONS, SYMBOLS AND UNITS**

For the purpose of this specification, the terms, definitions, abbreviations, symbols and units specified in ESA/SCC Basic Specification No. 21300 shall apply.



**TABLE 1(a) - TYPE VARIANTS**

| VARIANT | BASED ON TYPE | FIGURE | TERMINAL/LEAD MATERIAL AND FINISH |
|---------|---------------|--------|-----------------------------------|
| 01      | BXY42         | 2(a)   | D2                                |
| 02      | BXY42         | 2(b)   | D2                                |

**TABLE 1(b) - MAXIMUM RATINGS**

| No. | CHARACTERISTICS   | SYMBOL        | MAXIMUM RATING | UNIT | REMARKS          |
|-----|---|---------------|----------------|------|------------------|
| 1   | D.C. Reverse Voltage  | $V_R$         | -50            | V    | -                |
| 2   | Peak Forward Current  | $I_{FM}$      | 5.0            | A    | Note 1           |
| 3   | Power Dissipation<br>Variant 01<br>Variant 02                     | $P_D$         | 350<br>600     | mW   | Note 2<br>Note 3 |
| 4   | Operating Temperature Range                                       | $T_{op}$      | -55 to +175    | °C   | $T_{case}$       |
| 5   | Storage Temperature Range   | $T_{stg}$     | -65 to +175    | °C   | -                |
| 6   | Soldering Temperature   | $T_{sol}$     | +250           | °C   | Note 4           |
| 7   | Junction Temperature  | $T_J$         | +175           | °C   | -                |
| 8   | Thermal Resistance (Junction to Case)<br>Variant 01<br>Variant 02 | $R_{TH(J-C)}$ | 350<br>200     | °C/W | $I_F = 1.0mA$    |

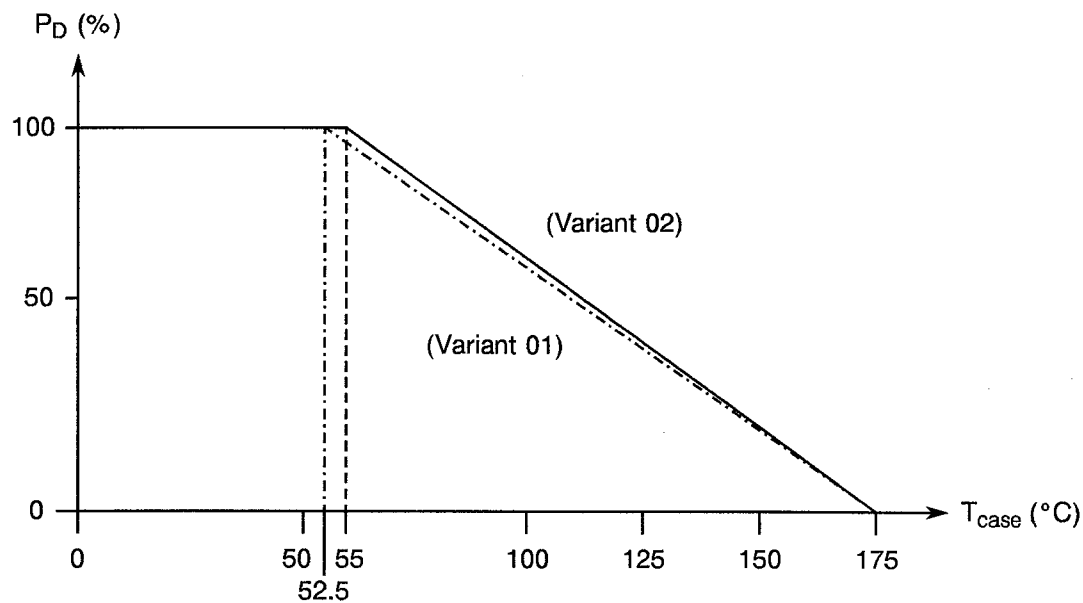
**NOTES**

- At  $t_p = 1.0\mu s$ , Duty Cycle = 0.001%.
- At  $T_{case} = +52.5^\circ C$ . For derating at  $T_{case} > +52.5^\circ C$ , see Figure 1.
- At  $T_{case} = +55^\circ C$ . For derating at  $T_{case} > +55^\circ C$ , see Figure 1.
- Duration 5 seconds maximum and the same termination shall not be resoldered until 5 minutes have elapsed.





**FIGURE 1 - PARAMETER DERATING INFORMATION**

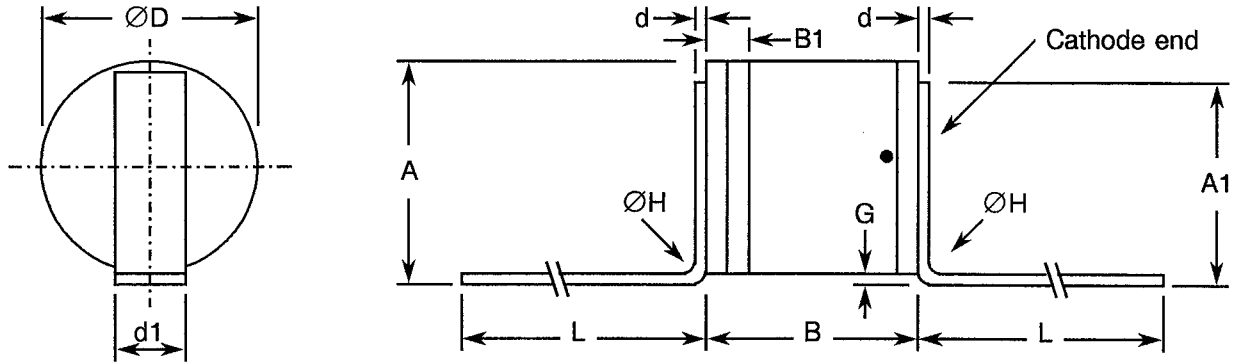


Power Dissipation versus Temperature

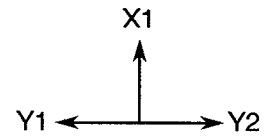


**FIGURE 2 - PHYSICAL DIMENSIONS**

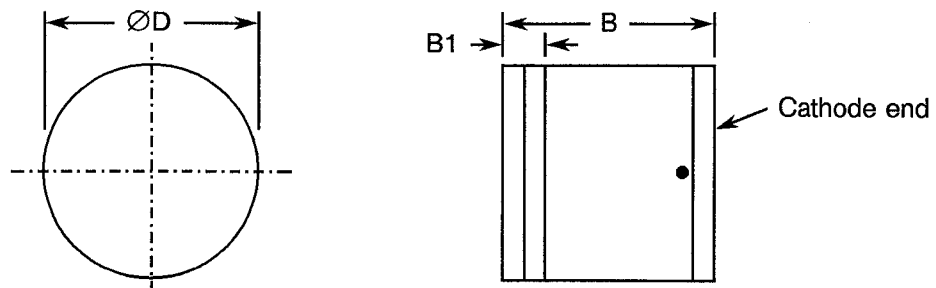
**FIGURE 2(a) - VARIANT 01**



| SYMBOL          | MILLIMETRES |      |
|-----------------|-------------|------|
|                 | MIN.        | MAX. |
| A               | 1.40        | 1.95 |
| A1              | 1.05        | 1.25 |
| B               | 1.15        | 1.35 |
| B1              | -           | 0.40 |
| d               | 0.06        | 0.10 |
| d1              | 0.40        | 0.60 |
| $\varnothing D$ | 1.30        | 1.45 |
| G               | 0.10        | 0.50 |
| $\varnothing H$ | -           | 0.30 |
| L               | 5.50        | -    |

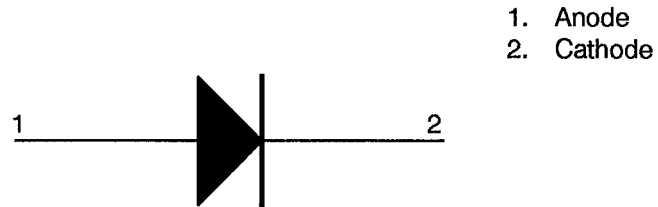


**FIGURE 2(b) - VARIANT 02**



| SYMBOL          | MILLIMETRES |      |
|-----------------|-------------|------|
|                 | MIN.        | MAX. |
| B               | 1.15        | 1.35 |
| B1              | -           | 0.40 |
| $\varnothing D$ | 1.30        | 1.45 |

**FIGURE 3 - FUNCTIONAL DIAGRAM**



**NOTES**

1. The cathode end shall be marked with a black dot or band. The marking will not be on the cathode connection but adjacent to it.



#### 4. REQUIREMENTS

##### 4.1 GENERAL

The complete requirements for procurement of the diodes specified herein shall be as stated in this specification and ESA/SCC Generic Specification No. 5010 for Discrete Microwave Semiconductor Components. Deviations from the Generic Specification, applicable to this specification only, are listed in Para. 4.2.

Deviations from the applicable Generic Specification and this Detail Specification, formally agreed with specific Manufacturers on the basis that the alternative requirements are equivalent to the ESA/SCC requirements and do not affect the components' reliability, are listed in the appendices attached to this specification.

##### 4.2 DEVIATIONS FROM GENERIC SPECIFICATION

###### 4.2.1 Deviations from Special In-process Controls

- (a) Para. 5.2.2, Total Dose Irradiation Testing: Shall be performed during qualification and extension of qualification.
- (b) Para. 5.2.2, Total Dose Irradiation Testing: Shall be performed during procurement on a lot acceptance basis at the total dose irradiation level specified in the purchase order.
- (c) Para. 5.3, Wafer Lot Acceptance: Shall be performed as an S.E.M. Inspection only.

###### 4.2.2 Deviations from Final Production Tests (Chart II)

- (a) Para. 9.2.2, Die Shear: Forces need not be recorded and the residual die area shall be  $\geq 50\%$  of the original die size.
- (b) Para. 9.6, Constant Acceleration: Shall not be performed.
- (c) Para. 9.14, Vibration, Variable Frequency: Shall not be performed.
- (d) Para. 9.7, PIND test shall be performed in accordance with condition 'A'; it may be performed at any point after indicated position in Chart II.

###### 4.2.3 Deviations from Burn-in and Electrical Measurements (Chart III)

- (a) Para. 9.9.1, Initial Parameter Drift Value Measurements: Parameters measured in Chart II shall not be repeated during electrical measurements at room temperature.
- (b) Para. 9.12, Radiographic Inspection: Shall be performed in X and Z axes only, exposure 100kV, duration 5 minutes.
- (c) Para. 9.12, Radiographic Inspection may be performed at any point after completed Power Burn-in (Chart III).



#### 4.2.4 Deviations from Qualification Tests (Chart IV)

- (a) Para. 9.2.2, Die Shear: Forces need not be recorded and the residual die area shall be  $\geq 50\%$  of the original die size.
- (b) Para. 9.15, Constant Acceleration: Shall not be performed.
- (d) Para. 9.20, Operating Life: Only one Operating Life Test shall be performed on 30 pieces.
- (e) Para. 9.23, Special Testing: Shall not be performed.

#### 4.2.5 Deviations from Lot Acceptance Tests (Chart V)

- (a) Para. 9.14, Vibration: Shall not be performed.
- (b) Para. 9.5, Thermal shock and Para. 9.16, Moisture Resistance, shall be done in sequence on all 6 components of the Environmental/Mechanical Subgroups.
- (c) Para. 9.15, Constant Acceleration: Shall not be performed.
- (d) Para. 9.20, Operating Life: Only one Operating Life Test shall be performed on 16 components.
- (e) Para. 9.23, Special Testing: Shall not be performed.

### 4.3 MECHANICAL AND ENVIRONMENTAL REQUIREMENTS

#### 4.3.1 Dimension Check

The dimensions of the diodes specified herein shall be checked. They shall conform to those shown in Figure 2.

#### 4.3.2 Weight

The maximum weight of the diodes specified herein shall be 0.02 grammes.

#### 4.3.3 Terminal Strength

The requirements for terminal strength testing are specified in Section 9 of ESA/SCC Generic Specification No. 5010. The test conditions shall be as follows:-

Test Condition : 'A' (Tension).

Force : 1.22 Newtons.

Duration : 5.0 seconds.

Applicable to Variant 01 only.

### 4.4 MATERIALS AND FINISHES

The materials and finishes shall be as specified herein. Where a definite material is not specified, a material which will enable the diodes specified herein to meet the performance requirements of this specification shall be used. Acceptance or approval of any constituent material does not guarantee acceptance of the finished product.

#### 4.4.1 Case

Cylinder ring: Ceramic.



4.4.2 Terminal and Lead Material and Finish

The terminals shall be Type 'D' with Type '2' finish in accordance with the requirements of ESA/SCC Basic Specification No. 23500. The ribbon leads of Type Variant 01 shall be Type 'D' with Type '2' finish in accordance with the requirements of ESA/SCC Basic Specification No. 23500.

4.5 MARKING

4.5.1 General

The marking of all components delivered to this specification shall be in accordance with the requirements of ESA/SCC Basic Specification No. 21700 and the following paragraphs. When the component is too small to accommodate all of the marking specified, as much as space permits shall be marked and the marking information, in full, shall accompany the component in its primary package.

The information to be marked and the order of precedence, shall be as follows:-

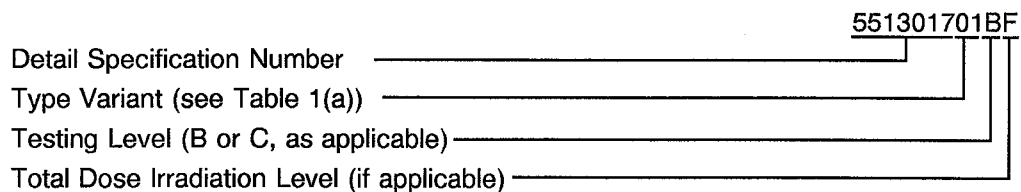
- (a) Cathode Identification.
- (b) The SCC Component Number.
- (c) Traceability Information.

4.5.2 Cathode Identification

Cathode identification shall be as shown in Figures 2 and 3 of this specification.

4.5.3 The SCC Component Number

Each component shall bear the SCC Component Number which shall be constituted and marked as follows:



The Total Dose Irradiation Level designation shall be added for those devices for which a sample has been successfully tested to the level in question. For these devices, a code letter shall be added in accordance with the requirements of ESA/SCC Basic Specification No. 22900.

4.5.4 Traceability Information

Each component shall be marked in respect of traceability information as defined in ESA/SCC Basic Specification No. 21700.

4.6 ELECTRICAL MEASUREMENTS

4.6.1 Electrical Measurements at Room Temperature

The parameters to be measured at room temperature are scheduled in Table 2. Unless otherwise specified, the measurements shall be performed at  $T_{amb} = +22 \pm 3$  °C.

4.6.2 Electrical Measurements at High and Low Temperatures

The parameters to be measured at high and low temperatures are scheduled in Table 3. Unless otherwise specified, the measurements shall be performed at  $T_{amb} = +125$ °C.



#### 4.6.3 Circuits for Electrical Measurements

Circuits for use in performing electrical measurements listed in Table 2 of this specification are shown in Figure 4.

#### 4.7 BURN-IN TESTS

Burn-in shall be Category 3 of Chart III(a).

##### 4.7.1 Parameter Drift Values

The parameter drift values applicable to burn-in are specified in Table 4 of this specification. Unless otherwise stated, measurements shall be performed at  $T_{amb} + 22 \pm 3$  °C. The parameter drift values ( $\Delta$ ) applicable to the scheduled parameters shall not be exceeded. In addition to these drift value requirements for a given parameter, the appropriate limit value specified in Table 2 shall not be exceeded.

##### 4.7.2 Conditions for High Temperature Reverse Bias Burn-in

The requirements for high temperature reverse bias burn-in are specified in Section 7 of ESA/SCC Generic Specification No. 5010. The conditions for high temperature reverse bias burn-in shall be as specified in Table 5(a) of this specification.

##### 4.7.3 Electrical Circuit for High Temperature Reverse Bias Burn-in

The circuit for use in performing the H.T.R.B. burn-in tests is shown in Figure 5(a) of this specification.

##### 4.7.4 Conditions for Power Burn-in

The requirements for power burn-in are specified in Section 7 of ESA/SCC Generic Specification No. 5010. The conditions for power burn-in shall be as specified in Table 5(b) of this specification.

##### 4.7.5 Electrical Circuit for Power Burn-in

The circuit for use in performing the power burn-in tests is shown in Figure 5(b) of this specification.

**TABLE 2 - ELECTRICAL MEASUREMENTS AT ROOM TEMPERATURE - D.C. PARAMETERS**

| No. | CHARACTERISTICS   | SYMBOL   | MIL-STD-750<br>TEST METHOD | TEST<br>CONDITIONS | LIMITS |      | UNIT    |
|-----|-------------------|----------|----------------------------|--------------------|--------|------|---------|
|     |                   |          |                            |                    | MIN.   | MAX. |         |
| 1   | Reverse Current 1 | $I_{R1}$ | 4016                       | $V_R = -50V$       | -      | 10   | $\mu A$ |
| 2   | Reverse Current 2 | $I_{R2}$ | 4016                       | $V_R = -40V$       | -      | 5.0  | nA      |
| 3   | Forward Voltage   | $V_F$    | 4011                       | $I_F = 100mA$      | -      | 1.1  | V       |

**TABLE 2 - ELECTRICAL MEASUREMENTS AT ROOM TEMPERATURE - A.C. PARAMETERS**

| No. | CHARACTERISTICS              | SYMBOL   | MIL-STD-750<br>TEST METHOD | TEST<br>FIG. | TEST<br>CONDITIONS               | LIMITS |      | UNIT     |
|-----|------------------------------|----------|----------------------------|--------------|----------------------------------|--------|------|----------|
|     |                              |          |                            |              |                                  | MIN.   | MAX. |          |
| 4   | Total Capacitance            | $C_T$    | 4001                       | -            | $V_R = -20V$<br>$f = 1.0MHz$     | -      | 0.24 | pF       |
| 5   | Forward Resistance 1         | $R_{F1}$ | 4056                       | -            | $f = 100MHz$<br>$I_{F1} = 1.0mA$ | -      | 3.5  | $\Omega$ |
| 6   | Forward Resistance 2         | $R_{F2}$ | 4056                       | -            | $f = 100MHz$<br>$I_{F2} = 10mA$  | -      | 2.5  | $\Omega$ |
| 7   | Minority Carrier<br>Lifetime | $\tau_L$ | -                          | 4            | $I_F = 10mA$<br>$I_R = -6.0mA$   | 35     | -    | ns       |

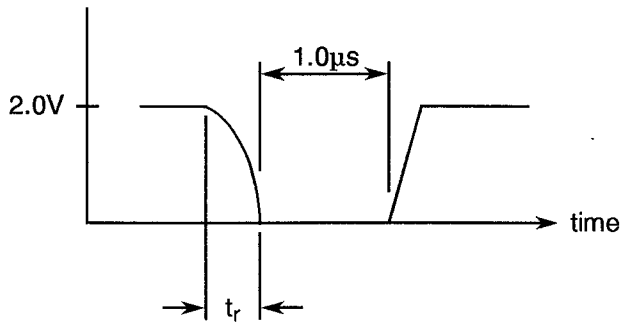
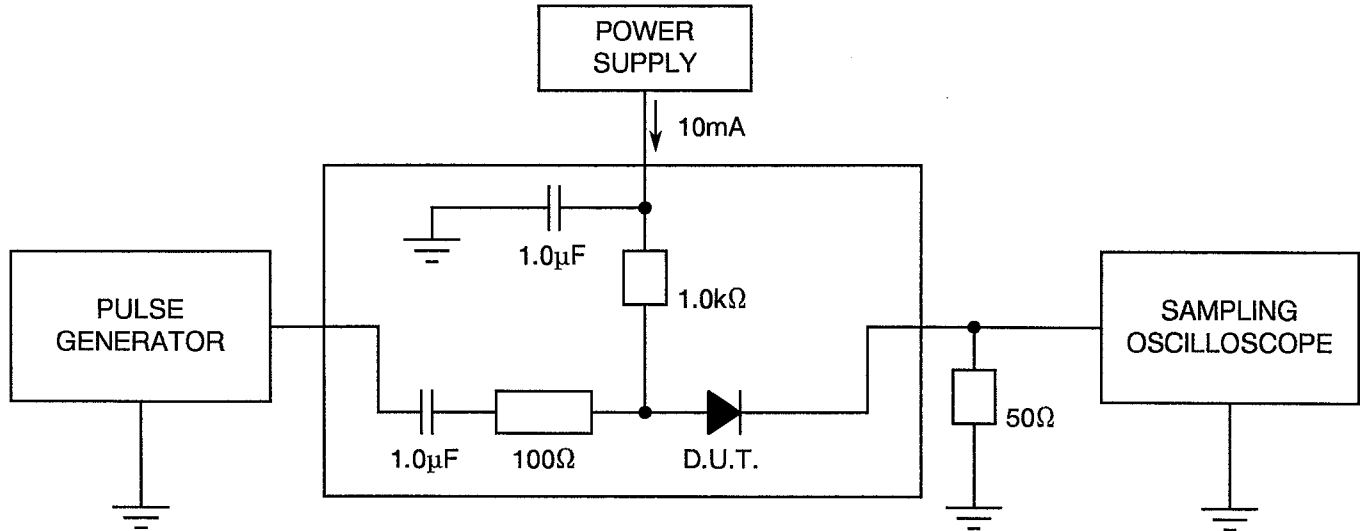
**TABLE 3 - ELECTRICAL MEASUREMENTS AT HIGH AND LOW TEMPERATURES**

| No. | CHARACTERISTICS   | SYMBOL   | SPEC. AND/OR<br>TEST METHOD | TEST<br>CONDITIONS | LIMITS |      | UNIT |
|-----|-------------------|----------|-----------------------------|--------------------|--------|------|------|
|     |                   |          |                             |                    | MIN.   | MAX. |      |
| 2   | Reverse Current 2 | $I_{R2}$ | As per Table 2              | As per Table 2     | -      | 100  | nA   |

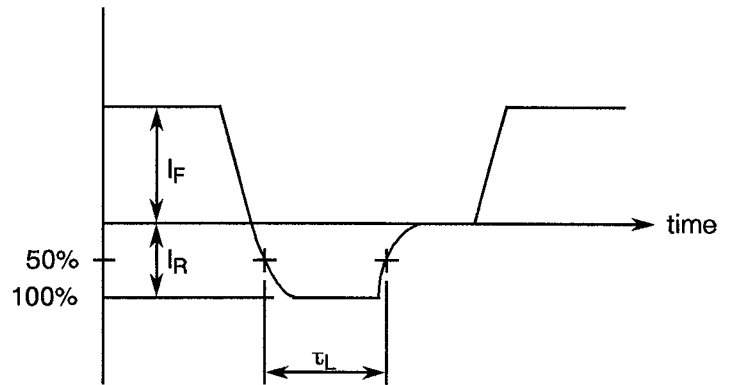




**FIGURE 4 - TEST CIRCUIT FOR MINORITY CARRIER LIFETIME MEASUREMENT**



Input wave shape



Output wave shape

**NOTES**

1. The value of the reverse current  $I_R$  is  $-6.0\text{mA}$  and the forward current  $I_F$  is  $10\text{mA}$ .
2. The lifetime ( $\tau_L$ ) is measured across the 50% points of the observed wave shape. The input pulse is provided by a pulse generator having a rise time of less than  $5.0\text{ns}$ . The output pulse is amplified and observed on a sampling oscilloscope.
3. Pulse length:  $1.0\mu\text{s}$ .
4. Duty cycle:  $\leq 33\%$ .

**TABLE 4 - PARAMETER DRIFT VALUES**

| No. | CHARACTERISTICS      | SYMBOL   | SPEC. AND/OR TEST METHOD | TEST CONDITIONS | CHANGE LIMITS ( $\Delta$ )              | UNIT    |
|-----|----------------------|----------|--------------------------|-----------------|---|---------|
| 2   | Reverse Current 2    | $I_{R2}$ | As per Table 2           | As per Table 2  | $\pm 3.0$ (1)                           | nA      |
| 3   | Forward Voltage      | $V_F$    | As per Table 2           | As per Table 2  | $\pm 20$ (1)<br>or (2)<br>$\pm 5.0$ (1) | mV<br>% |
| 5   | Forward Resistance 1 | $R_{F1}$ | As per Table 2           | As per Table 2  | $\pm 15$ (1)                            | %       |

**NOTES**

- $\Delta 1 = \Delta 2 = \Delta 3$ .
- Whichever is the greater, referred to the initial measurement.

**TABLE 5(a) - CONDITIONS FOR HIGH TEMPERATURE REVERSE BIAS BURN-IN**

| No. | CHARACTERISTICS     | SYMBOL    | CONDITIONS     | UNIT |
|-----|---------------------|-----------|----------------|------|
| 1   | Ambient Temperature | $T_{amb}$ | + 150(+ 0 - 5) | C    |
| 2   | Reverse Voltage     | $V_R$     | - 40           | V    |

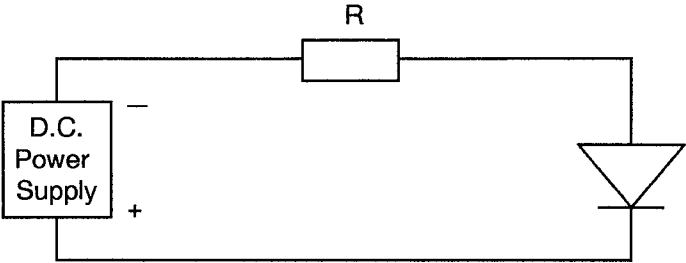
**NOTES**

- At the end of the H.T.R.B.,  $T_{amb}$  shall be decreased to room temperature and the reverse bias shall remain applied until  $T_{amb}$  is less than + 35°C.

**TABLE 5(b) - CONDITIONS FOR POWER BURN-IN AND OPERATING LIFE TESTS**

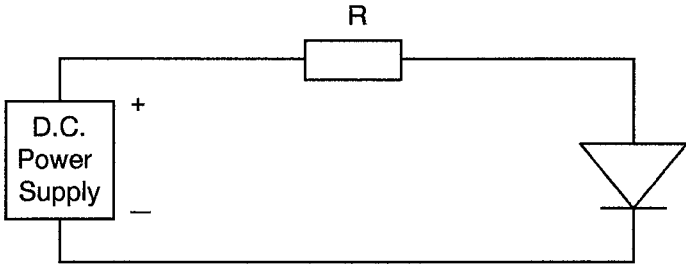
| No. | CHARACTERISTICS      | SYMBOL | CONDITIONS     | UNIT |
|-----|----------------------|--------|----------------|------|
| 1   | Junction Temperature | $T_j$  | + 175(+ 0 - 3) | °C   |
| 2   | Forward Current      | $I_F$  | 50             | mA   |

**FIGURE 5(a) - ELECTRICAL CIRCUIT FOR HIGH TEMPERATURE REVERSE BIAS BURN-IN**



- NOTES**  
1.  $R = 22k\Omega$

**FIGURE 5(b) - ELECTRICAL CIRCUIT FOR POWER BURN-IN AND OPERATING LIFE TESTS**



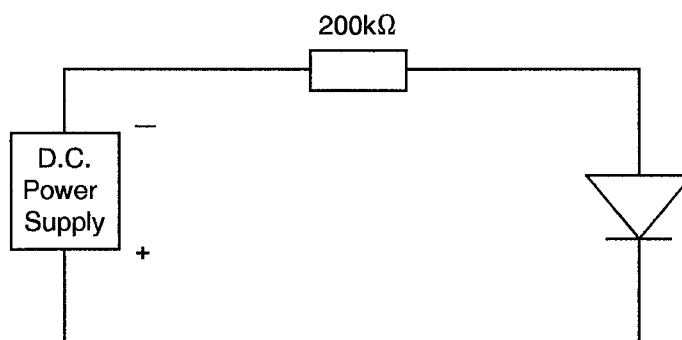
- NOTES**  
1.  $R = 3.9\Omega$



- 4.8 ENVIRONMENTAL AND ENDURANCE TESTS (CHARTS IV AND V OF ESA/SCC GENERIC SPECIFICATION NO. 5010)
- 4.8.1 Electrical Measurements on Completion of Environmental Tests  
The parameters to be measured on completion of environmental tests are scheduled in Table 2. Unless otherwise stated, the measurements shall be performed at  $T_{amb} = +22 \pm 3$  °C.
- 4.8.2 Electrical Measurements at Intermediate Points and on Completion of Endurance Tests  
The parameters to be measured at intermediate points and on completion of endurance tests are scheduled in Table 6. Unless otherwise stated, the measurements shall be performed at  $T_{amb} = +22 \pm 3$  °C.
- 4.8.3 Conditions for Operating Life Tests (Part of Endurance Testing)  
The requirements for operating life testing are specified in Section 9 of ESA/SCC Generic Specification No. 5010. The conditions for operating life testing are specified in Table 5(b) of this specification.
- 4.8.4 Electrical Circuits for Operating Life Tests  
The circuit to be used for performance of the operating life test shall be the same as shown in Figure 5(b) for Power Burn-in.
- 4.9 TOTAL DOSE IRRADIATION TESTING
- 4.9.1 Application  
If specified in Para. 4.2.1 of this specification, total dose irradiation testing shall be performed in accordance with the requirements of ESA/SCC Basic Specification No. 22900.
- 4.9.2 Bias Conditions  
Continuous bias shall be applied during irradiation testing as shown in Figure 6 of this specification.
- 4.9.3 Electrical Measurements  
The parameters to be measured prior to irradiation exposure are scheduled in Table 2 of this specification. Only devices which meet the requirements of Table 2 shall be included in the test sample.  
  
The parameters to be measured during and on completion of irradiation testing are scheduled in Table 7 of this specification.
- 4.10 SPECIAL TESTING  
Not applicable.

**TABLE 6 - ELECTRICAL MEASUREMENTS AT INTERMEDIATE POINTS AND ON COMPLETION OF ENDURANCE TESTING**

| No. | CHARACTERISTICS      | SYMBOL   | SPEC. AND/OR TEST METHOD | TEST CONDITIONS | LIMITS |      | UNIT          |
|-----|----------------------|----------|--------------------------|-----------------|--------|------|---------------|
|     |                      |          |                          |                 | MIN.   | MAX. |               |
| 1   | Reverse Current 1    | $I_{R1}$ | As per Table 2           | As per Table 2  | -      | 10   | $\mu\text{A}$ |
| 2   | Reverse Current 2    | $I_{R2}$ | As per Table 2           | As per Table 2  | -      | 5.0  | nA            |
| 3   | Forward Voltage      | $V_F$    | As per Table 2           | As per Table 2  | -      | 1.1  | V             |
| 4   | Total Capacitance    | $C_T$    | As per Table 2           | As per Table 2  | -      | 0.24 | pF            |
| 5   | Forward Resistance 1 | $R_{F1}$ | As per Table 2           | As per Table 2  | -      | 3.5  | $\Omega$      |
| 6   | Forward Resistance 2 | $R_{F2}$ | As per Table 2           | As per Table 2  | -      | 2.5  | $\Omega$      |

**FIGURE 6 - BIAS CONDITIONS FOR IRRADIATION TESTING****NOTES**

1. A reverse bias of  $V_R = -10\text{V}$  shall be applied.

**TABLE 7 - ELECTRICAL MEASUREMENTS DURING AND ON COMPLETION OF IRRADIATION TESTING**

| No. | CHARACTERISTICS      | SYMBOL   | SPEC. AND/OR TEST METHOD | TEST CONDITIONS | CHANGE LIMITS ( $\Delta$ ) | UNIT    |
|-----|----------------------|----------|--------------------------|-----------------|----------------------------|---------|
| 1   | Reverse Current 1    | $I_{R1}$ | As per Table 2           | As per Table 2  | $\pm 1.0$                  | $\mu A$ |
| 5   | Forward Resistance 1 | $R_{F1}$ | As per Table 2           | As per Table 2  | $\pm 35$                   | %       |

**NOTES**

1. The graph given below shall be used to determine the maximum permitted change on  $R_{F1}$ .

