



**CONNECTORS, ELECTRICAL,
FILTERED, RECTANGULAR,
NON-REMOVABLE SOLDER BUCKET CONTACTS,
BASED ON TYPE D*J
ESCC Detail Specification No. 3405/001**

**ISSUE 1
October 2002**



	ESCC Detail Specification		PAGE ii ISSUE 1
---	---------------------------	--	--------------------

LEGAL DISCLAIMER AND COPYRIGHT

European Space Agency, Copyright © 2002. All rights reserved.

The European Space Agency disclaims any liability or responsibility, to any person or entity, with respect to any loss or damage caused, or alleged to be caused, directly or indirectly by the use and application of this ESCC publication.

This publication, without the prior permission of the European Space Agency and provided that it is not used for a commercial purpose, may be:

- copied in whole in any medium without alteration or modification.
- copied in part, in any medium, provided that the ESCC document identification, comprising the ESCC symbol, document number and document issue, is removed.



europaean space agency
agence spatiale europ eennne

Pages 1 to 29

**CONNECTORS, ELECTRICAL,
FILTERED, RECTANGULAR,
NON-REMOVABLE SOLDER BUCKET CONTACTS,
BASED ON TYPE D*J**

ESA/SCC Detail Specification No. 3405/001



**space components
coordination group**

Issue/Rev.	Date	Approved by	
		SCCG Chairman	ESA Director General or his Deputy
Issue 1	February 1994	<i>P. Monm�eul</i>	<i>[Signature]</i>
Revision 'A'	January 1995	<i>P. Monm�eul</i>	<i>[Signature]</i>



SCC

ESA/SCC Detail Specification
No. 3405/001

Rev. 'A'

PAGE 2

ISSUE 1

DOCUMENTATION CHANGE NOTICE

Rev. Letter	Rev. Date	Reference	CHANGE Item	Approved DCR No.
		This specification supersedes the Detail Specifications No. 3401/026 and 3401/027		
'A'	Jan. '95	P1. Cover Page P2. DCN P24. Table 4 P27-29 Table 6	: Test No. 6 changed to 7 : Editorial corrections : Item 11, Electrical Measurements deleted	None None 23665 23665 221194



TABLE OF CONTENTS

	<u>Page</u>
1. <u>GENERAL</u>	5
1.1 Scope	5
1.2 Type Variants	5
1.3 Maximum Ratings	5
1.4 Parameter Derating Information	5
1.5 Physical Dimensions	5
2. <u>APPLICABLE DOCUMENTS</u>	18
3. <u>TERMS, DEFINITIONS, ABBREVIATIONS, SYMBOLS AND UNITS</u>	18
4. <u>REQUIREMENTS</u>	18
4.1 General	18
4.2 Deviations from Generic Specification	18
4.2.1 Deviations from Special In-process Controls	18
4.2.2 Deviations from Final Production Tests	18
4.2.3 Deviations from Burn-in and Electrical Measurements	18
4.2.4 Deviations from Qualification Tests	19
4.2.5 Deviations from Lot Acceptance Tests	19
4.3 Mechanical Requirements	19
4.3.1 Dimension Check	19
4.3.2 Weight	19
4.3.3 Contact Capability	19
4.3.4 Contact Retention (in Insert)	19
4.3.5 Mating and Unmating Forces	19
4.3.6 Insert Retention (in Shell)	19
4.3.7 Engagement and Separation Forces	19
4.3.8 Oversize Pin Exclusion	20
4.3.9 Probe Damage	20
4.3.10 Solderability	20
4.4 Materials and Finishes	20
4.4.1 Shells	20
4.4.2 Inserts	20
4.4.3 Contacts	20
4.4.4 Ground Plane	20
4.4.5 Guiding and Locking Devices	20
4.5 Marking	21
4.5.1 General	21
4.5.2 Contact Identification	21
4.5.3 The SCC Component Number	21
4.5.4 Characteristics	21
4.5.5 Traceability Information	21
4.6 Electrical Measurements	21
4.6.1 Electrical Measurements at Room Temperature	21
4.6.2 Electrical Measurements at High and Low Temperatures	21
4.6.3 Circuit for Electrical Measurements	21
4.7 Burn-in and Electrical Measurements	22
4.7.1 Parameter Drift Values	22
4.7.2 Conditions for Burn-in	22
4.7.3 Electrical Circuits for Burn-in	22
4.8 Environmental and Endurance Tests	25
4.8.1 Measurements and Inspections on Completion of Environmental Tests	25
4.8.2 Measurements and Inspections at Intermediate Points during Endurance Tests	25

	ESA/SCC Detail Specification No. 3405/001		PAGE 4 ISSUE 1
---	--	--	-------------------

	<u>Page</u>
4.8.3 Measurements and Inspections on Completion of Endurance Tests	25
4.8.4 Conditions for Operating Life Test	25
4.8.5 Electrical Circuits for Operating Life Tests	25
4.8.6 Conditions for High Temperature Storage Test	25

TABLES

1(a) Type Variants	6
1(b) Maximum Ratings	9
2 Electrical Measurements at Room Temperature	23
3 Electrical Measurements at High and Low Temperatures	24
4 Parameter Drift Values	24
5 Conditions for Burn-in and Operating Life Test	25
6 Measurements and Inspections on Completion of Environmental Tests and at Intermediate Points and on Completion of Endurance Tests	26

FIGURES

1 Parameter Derating Information	9
2 Physical Dimensions	11
3 Functional Diagrams	17

APPENDICES (Applicable to specific Manufacturers only)
 None.

	<p style="text-align: center;">ESA/SCC Detail Specification No. 3405/001</p>	<p>PAGE 5 ISSUE 1</p>
---	--	---------------------------

1. **GENERAL**

1.1 **SCOPE**

This specification details the ratings, physical and electrical characteristics, test and inspection data for Connectors, Electrical, Filtered, Rectangular, with Non-Removable Solder Bucket Contacts, based on Type D*J. It shall be read in conjunction with:-

ESA/SCC Generic Specification No. 3405, Connectors, Electrical, Filtered, Circular and Rectangular.

ESA/SCC Detail Specification No. 3401/022, Accessories for Rectangular Connectors 3401/001, 3401/002 and Connector Savers 3401/020.

the requirements of which are supplemented herein.

1.2 **TYPE VARIANTS**

The different sizes of the connectors specified herein, which are also covered by this specification, together with their electrical and mechanical characteristics, are given in Table 1(a).

1.3 **MAXIMUM RATINGS**

The maximum ratings, which shall not be exceeded at any time during use or storage, applicable to the connectors specified herein, are scheduled in Table 1(b).

1.4 **PARAMETER DERATING INFORMATION**

The applicable derating information for the connectors specified herein is shown in Figure 1.

1.5 **PHYSICAL DIMENSIONS**

The physical dimensions of the connectors specified herein are shown in Figure 2.

TABLE 1(a) - TYPE VARIANTS

TYPE VARIANT	No. OF CONTACTS	SHELL SIZE	CONTACT TYPE	MAX. WEIGHT (g)	MATING FORCE (N. max)	UNMATING FORCE	
						N. min	N. max
01	9	E	Male	12.0	30	3.5	20
02	9	E	Female	13.5	30	3.5	20
03	15	A	Male	18.5	50	4.5	34
04	15	A	Female	20.5	50	4.5	34
05	25	B	Male	28.0	83	8.0	55
06	25	B	Female	31.0	83	8.0	55
07	37	C	Male	38.5	123	11.0	83
08	37	C	Female	42.0	123	11.0	83
09	50	D	Male	47.0	166	14.5	120
10	50	D	Female	51.0	166	14.5	120

FILTER ARRANGEMENTS - VARIANTS 01-02

SUB-VARIANTS	CONTACT POSITION								
	1	2	3	4	5	6	7	8	9
100	L	L	L	L	L	L	L	L	L
101	M	M	M	M	M	M	M	M	M
102	S	S	S	S	S	S	S	S	S
103	H	H	H	H	H	H	H	H	H
104	G	NF	G	NF	G	NF	G	NF	G
105	L	L	M	S	S	L	M	M	H

NOTES

- L = Low Frequency, M = Medium Frequency, S = Standard Frequency, H = High Frequency, NF = Non-filtered Contact, G = Grounded Contact.



TABLE 1(a) - TYPE VARIANTS (CONTINUED)

FILTER ARRANGEMENTS - VARIANTS 03-04

SUB-VARIANTS	CONTACT POSITION														
	1	2	3	4	5	6	7	8	9	10	11	12	13	14	15
100	L	L	L	L	L	L	L	L	L	L	L	L	L	L	L
101	M	M	M	M	M	M	M	M	M	M	M	M	M	M	M
102	S	S	S	S	S	S	S	S	S	S	S	S	S	S	S
103	H	H	H	H	H	H	H	H	H	H	H	H	H	H	H

NOTES

1. L=Low Frequency, M=Medium Frequency, S=Standard Frequency, H=High Frequency.

FILTER ARRANGEMENTS - VARIANTS 05-06

SUB-VARIANTS	CONTACT POSITION																								
	1	2	3	4	5	6	7	8	9	10	11	12	13	14	15	16	17	18	19	20	21	22	23	24	25
100	L	L	L	L	L	L	L	L	L	L	L	L	L	L	L	L	L	L	L	L	L	L	L	L	L
101	M	M	M	M	M	M	M	M	M	M	M	M	M	M	M	M	M	M	M	M	M	M	M	M	M
102	S	S	S	S	S	S	S	S	S	S	S	S	S	S	S	S	S	S	S	S	S	S	S	S	S
103	H	H	H	H	H	H	H	H	H	H	H	H	H	H	H	H	H	H	H	H	H	H	H	H	H
104	L	L	L	L	M	M	M	M	M	S	S	H	H	L	L	L	L	M	M	M	M	S	S	H	H

NOTES

1. L=Low Frequency, M=Medium Frequency, S=Standard Frequency, H=High Frequency.



ES&S

ESA/SCC Detail Specification

No. 3405/001

PAGE 8

ISSUE 1

TABLE 1(a) - TYPE VARIANTS (CONTINUED)

FILTER ARRANGEMENTS - VARIANTS 07-08

SUB-VARIANTS	CONTACT POSITION																																						
	1	2	3	4	5	6	7	8	9	10	11	12	13	14	15	16	17	18	19	20	21	22	23	24	25	26	27	28	29	30	31	32	33	34	35	36	37		
100	L	L	L	L	L	L	L	L	L	L	L	L	L	L	L	L	L	L	L	L	L	L	L	L	L	L	L	L	L	L	L	L	L	L	L	L	L	L	
101	M	M	M	M	M	M	M	M	M	M	M	M	M	M	M	M	M	M	M	M	M	M	M	M	M	M	M	M	M	M	M	M	M	M	M	M	M	M	
102	S	S	S	S	S	S	S	S	S	S	S	S	S	S	S	S	S	S	S	S	S	S	S	S	S	S	S	S	S	S	S	S	S	S	S	S	S	S	
103	H	H	H	H	H	H	H	H	H	H	H	H	H	H	H	H	H	H	H	H	H	H	H	H	H	H	H	H	H	H	H	H	H	H	H	H	H	H	H

NOTES

1. L = Low Frequency, M = Medium Frequency, S = Standard Frequency, H = High Frequency.

FILTER ARRANGEMENTS - VARIANTS 09-10

SUB-VARIANTS	CONTACT POSITION																																																					
	1	2	3	4	5	6	7	8	9	10	11	12	13	14	15	16	17	18	19	20	21	22	23	24	25	26	27	28	29	30	31	32	33	34	35	36	37	38	39	40	41	42	43	44	45	46	47	48	49	50				
100	L	L	L	L	L	L	L	L	L	L	L	L	L	L	L	L	L	L	L	L	L	L	L	L	L	L	L	L	L	L	L	L	L	L	L	L	L	L	L	L	L	L	L	L	L	L	L	L	L	L	L			
101	M	M	M	M	M	M	M	M	M	M	M	M	M	M	M	M	M	M	M	M	M	M	M	M	M	M	M	M	M	M	M	M	M	M	M	M	M	M	M	M	M	M	M	M	M	M	M	M	M	M	M	M		
102	S	S	S	S	S	S	S	S	S	S	S	S	S	S	S	S	S	S	S	S	S	S	S	S	S	S	S	S	S	S	S	S	S	S	S	S	S	S	S	S	S	S	S	S	S	S	S	S	S	S	S	S	S	
103	H	H	H	H	H	H	H	H	H	H	H	H	H	H	H	H	H	H	H	H	H	H	H	H	H	H	H	H	H	H	H	H	H	H	H	H	H	H	H	H	H	H	H	H	H	H	H	H	H	H	H	H		
104	L	L	L	L	L	M	M	M	S	H	H	H	L	L	L	L	M	M	S	S	S	H	H	L	L	L	L	L	L	L	L	L	L	L	L	L	L	L	L	L	L	L	L	L	L	L	L	L	L	L	L	L	L	L

NOTES

1. L = Low Frequency, M = Medium Frequency, S = Standard Frequency, H = High Frequency.

TABLE 1(b) - MAXIMUM RATINGS

No.	CHARACTERISTICS	SYMBOL	MAXIMUM RATING		UNIT
			MIN.	MAX.	
1	Rated/Working Voltage - Low Frequency - Medium, Standard, High Frequency - Non-filtered - Grounded	U_R	-	100 200 300 Not applicable	Vdc
2	Rated Current	I_R	-	5	Adc
3	Capacitor a.c. Rated Current	I_{Rac}	-	250	mArms
4	Operating Temperature Range	T_{op}	- 55	+ 125	°C
5	Storage Temperature Range	T_{stg}	- 65	+ 125	°C
6	Soldering Temperature	T_{sol}	-	+ 260 (1)	°C

NOTES

- Duration 10 seconds maximum and the same contact shall not be resoldered until 3 minutes have elapsed.

FIGURE 1 - PARAMETER DERATING INFORMATION

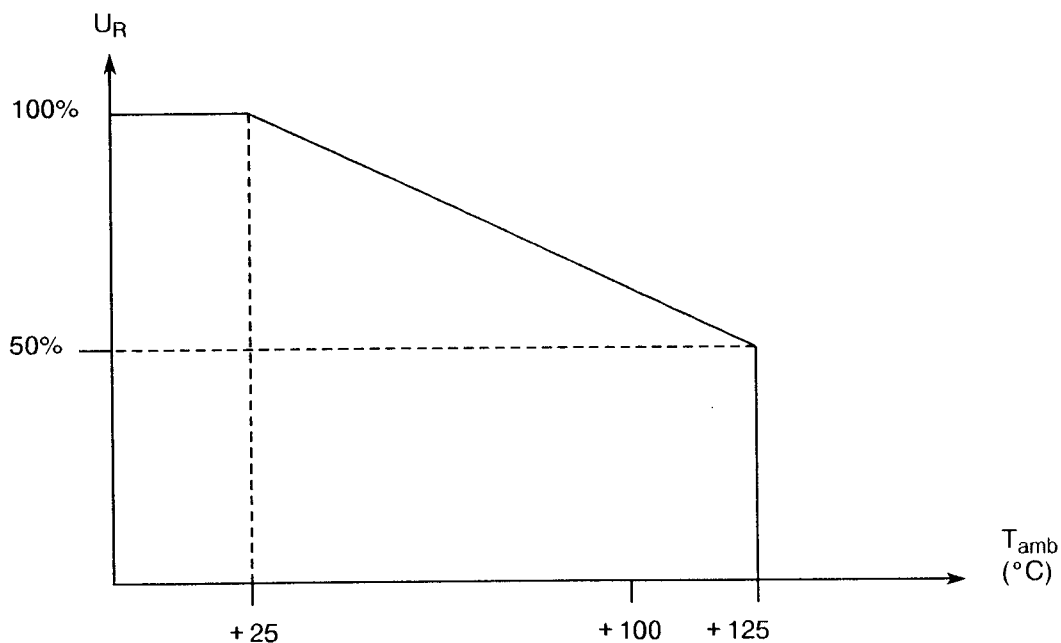

Filtered Contacts Rated Voltage versus Temperature



FIGURE 1 - PARAMETER DERATING INFORMATION (CONTINUED)

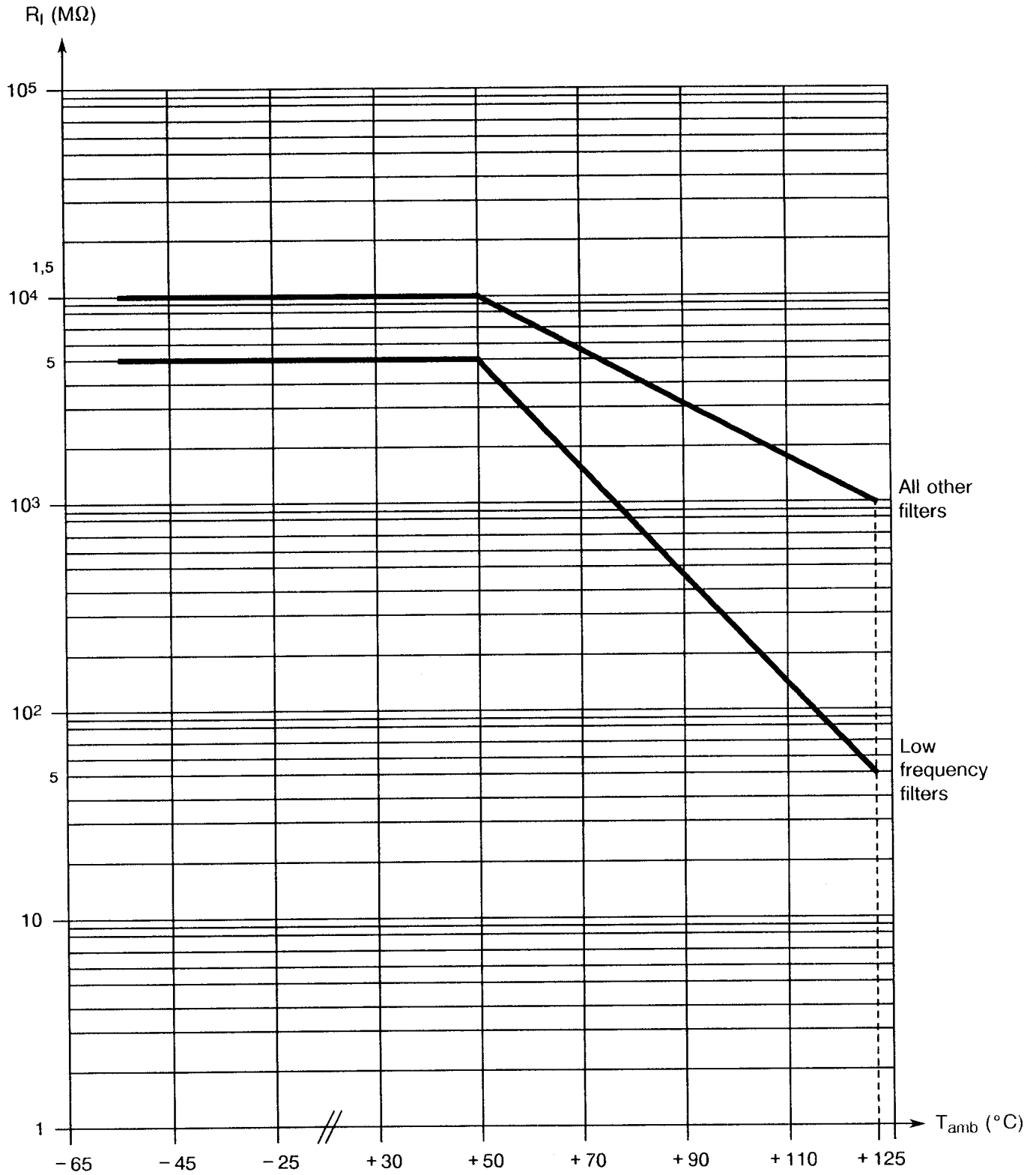

Filtered Contacts Insulation Resistance versus Temperature



FIGURE 2 - PHYSICAL DIMENSIONS

FIGURE 2(a) - RECEPTACLES AND PLUGS

VARIANTS 01, 02 - SHELL SIZE E

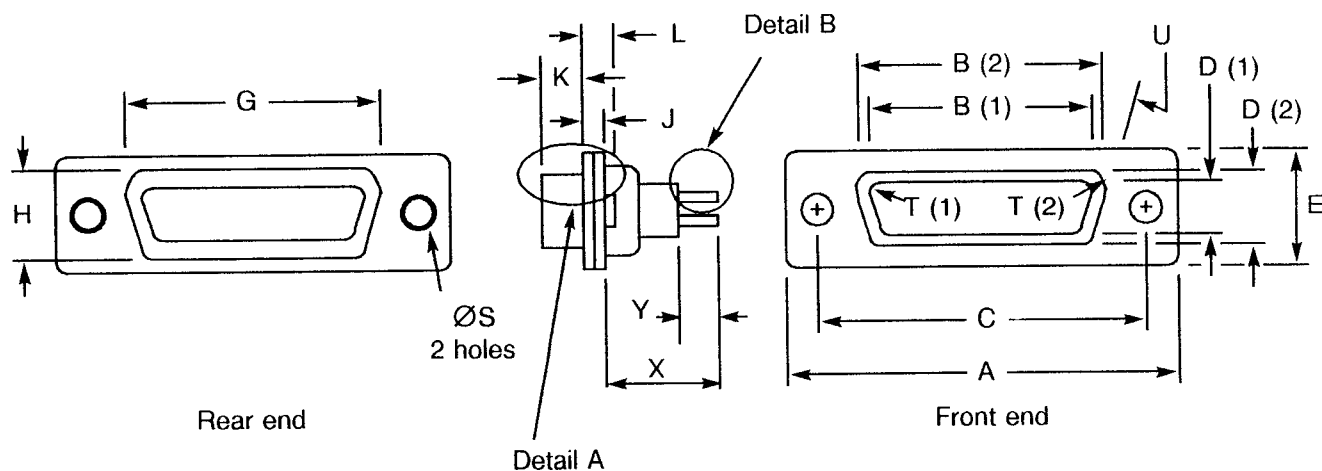

DETAIL A

DETAIL B

Spherical. A 0.3mm max diameter flat is permitted

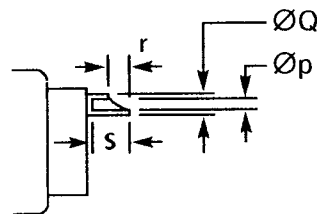
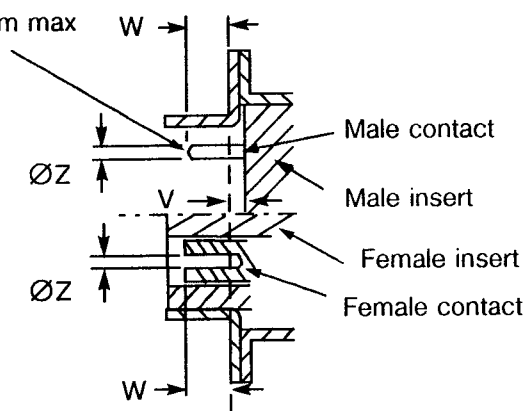

Ref. Plane

NOTES

1. Inside dimension for connectors with male contacts.
2. Outside dimension for connectors with female contacts.
3. All dimensions are in millimetres (angles in degrees).
4. Underlined dimensions, in table, are critical to ensure intermateability.

Variants	Symbol/ Dim.	A	<u>B</u>	<u>C</u>	<u>D</u>	E	G	H	J	<u>K</u>	L	ØS	<u>T</u>	<u>U</u>	<u>V</u>	W	X	Y	<u>ØZ</u>	Øp	ØQ	r	s
01	min.	30.43	16.79	24.87	8.23	12.17	19.02	10.46	0.51	5.82	0.89	2.92	2.59	9.0	0	4.03	-	4.5	0.99	1.10	1.45	1.85	2.40
	max.	31.19	17.04	25.12	8.48	12.93	19.53	10.97	1.02	6.13	1.52	3.20	2.69	11.0	0.4	-	22	-	1.04	1.15	1.51	2.15	-
02	min.	30.43	16.21	24.87	7.77	12.17	19.02	10.46	0.51	5.87	0.89	2.92	2.46	9.0	-	3.63	-	4.5	1.07	1.10	1.45	1.85	2.40
	max.	31.19	16.46	25.12	8.03	12.93	19.53	10.97	1.02	6.30	1.52	3.20	2.62	11.0	-	-	22	-	1.14	1.15	1.51	2.15	-

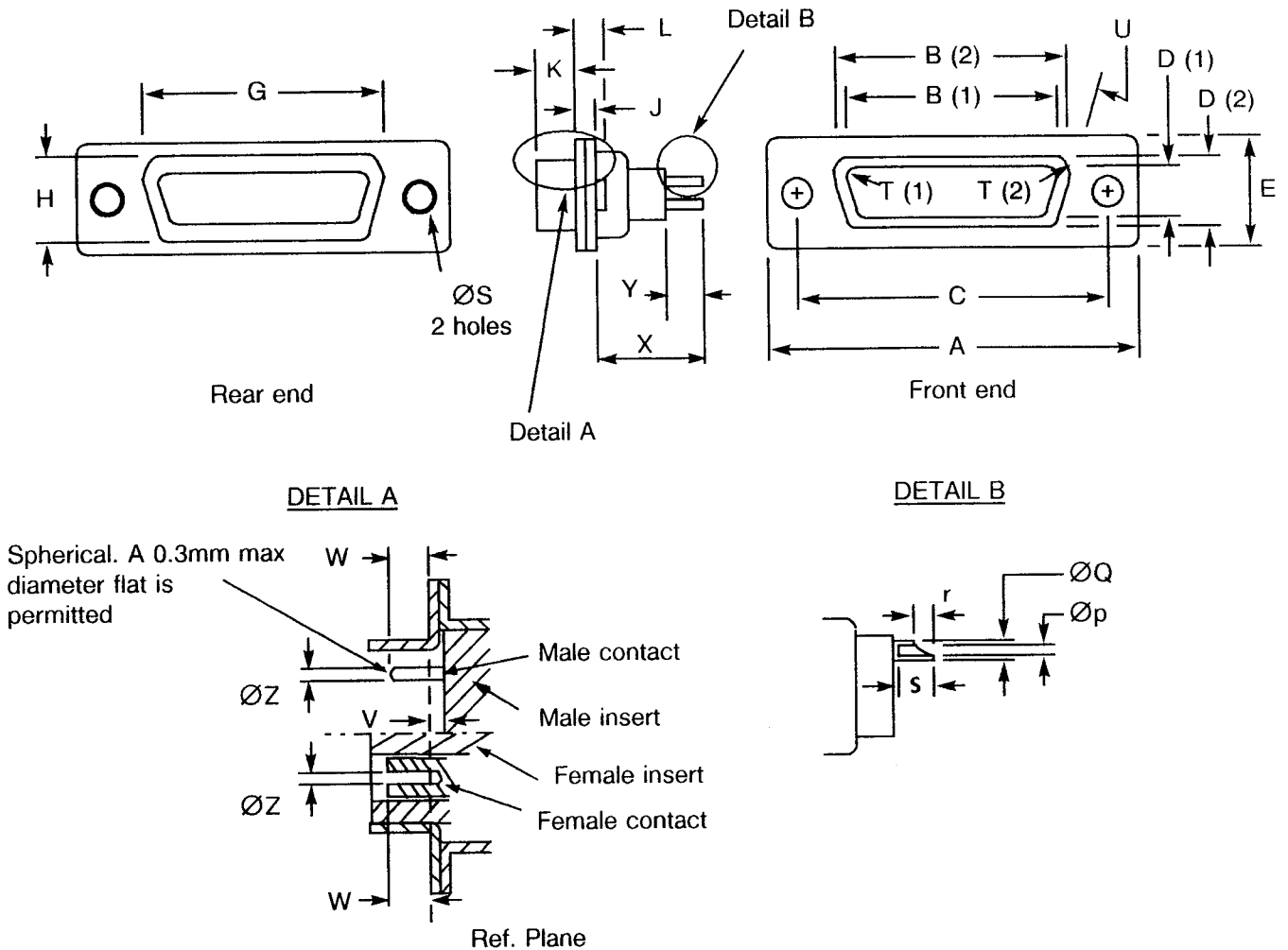
FIGURE 2 - PHYSICAL DIMENSIONS
FIGURE 2(a) - RECEPTACLES AND PLUGS
VARIANTS 03, 04 - SHELL SIZE A

NOTES

1. Inside dimension for connectors with male contacts.
2. Outside dimension for connectors with female contacts.
3. All dimensions are in millimetres (angles in degrees).
4. Underlined dimensions, in table, are critical to ensure intermateability.

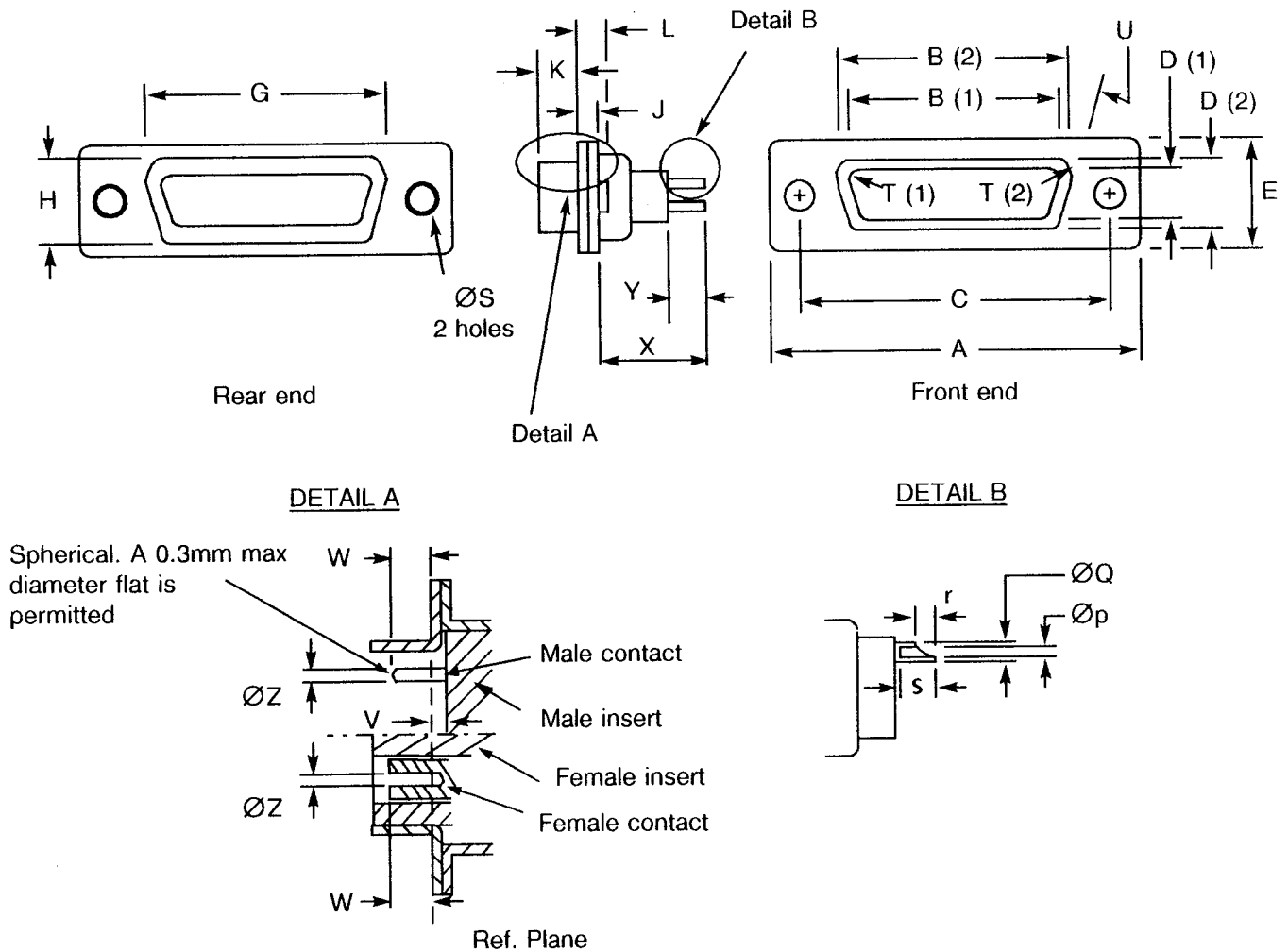
Variants	Symbol/ Dim.	A	<u>B</u>	<u>C</u>	<u>D</u>	E	G	H	J	<u>K</u>	L	$\varnothing S$	<u>I</u>	<u>U</u>	<u>V</u>	W	X	Y	<u>$\varnothing Z$</u>	$\varnothing p$	$\varnothing Q$	r	s
03	min.	38.76	25.12	33.20	8.23	12.17	27.25	10.46	0.51	5.82	0.89	2.92	2.59	9.0	0	4.03	-	4.5	0.99	1.10	1.45	1.85	2.40
	max.	39.52	25.37	33.45	8.48	12.93	27.76	10.97	1.02	6.13	1.52	3.20	2.69	11.0	0.4	-	22	-	1.04	1.15	1.51	2.15	-
04	min.	38.76	24.54	33.20	7.77	12.17	27.25	10.46	0.51	5.87	0.89	2.92	2.46	9.0	-	3.63	-	4.5	1.07	1.10	1.45	1.85	2.40
	max.	39.52	24.79	33.45	8.03	12.93	27.76	10.97	1.02	6.30	1.52	3.20	2.62	11.0	-	-	22	-	1.14	1.15	1.51	2.15	-

FIGURE 2 - PHYSICAL DIMENSIONS
FIGURE 2(a) - RECEPTACLES AND PLUGS
VARIANTS 05, 06 - SHELL SIZE B

NOTES

1. Inside dimension for connectors with male contacts.
2. Outside dimension for connectors with female contacts.
3. All dimensions are in millimetres (angles in degrees).
4. Underlined dimensions, in table, are critical to ensure intermateability.

Variants	Symbol/ Dim.	A	<u>B</u>	<u>C</u>	<u>D</u>	E	G	H	J	<u>K</u>	L	ØS	T	<u>U</u>	V	W	X	Y	ØZ	Øp	ØQ	r	s
05	min.	52.65	38.84	46.91	8.23	12.17	41.02	10.46	0.51	5.69	1.05	2.92	2.59	9.0	0	3.81	-	4.5	0.99	1.10	1.45	1.85	2.40
	max.	53.42	39.09	47.17	8.48	12.93	41.53	10.97	1.24	6.13	1.78	3.20	2.69	11.0	0.6	-	22	-	1.04	1.15	1.51	2.15	-
06	min.	52.65	38.25	46.91	7.77	12.17	41.02	10.46	0.51	5.87	0.89	2.92	2.46	9.0	-	3.63	-	4.5	1.07	1.10	1.45	1.85	2.40
	max.	53.42	38.51	47.17	8.03	12.93	41.53	10.97	1.02	6.30	1.52	3.20	2.62	11.0	-	-	22	-	1.14	1.15	1.51	2.15	-

FIGURE 2 - PHYSICAL DIMENSIONS

FIGURE 2(a) - RECEPTACLES AND PLUGS

VARIANTS 07, 08 - SHELL SIZE C

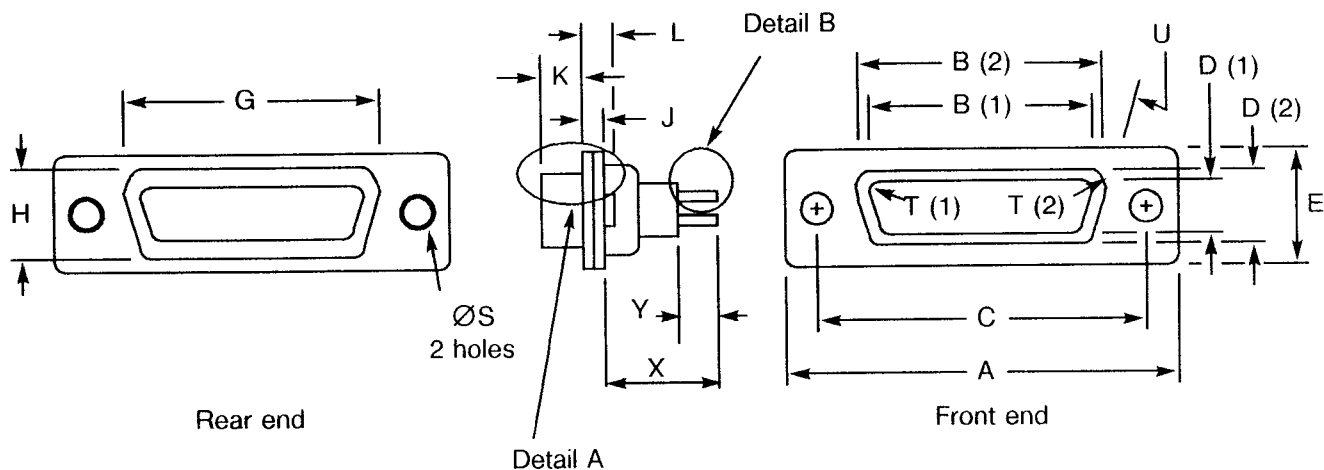

DETAIL A

DETAIL B

Spherical. A 0.3mm max diameter flat is permitted

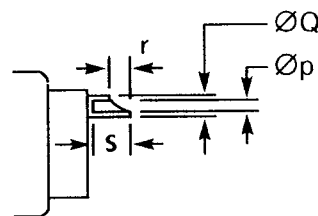
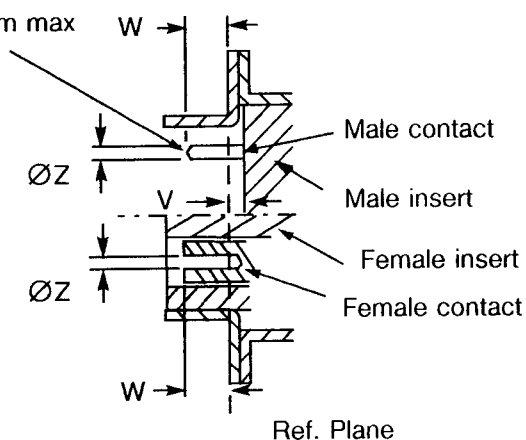

NOTES

1. Inside dimension for connectors with male contacts.
2. Outside dimension for connectors with female contacts.
3. All dimensions are in millimetres (angles in degrees).
4. Underlined dimensions, in table, are critical to ensure intermateability.

Variants	Symbol/ Dim.	A	<u>B</u>	<u>C</u>	<u>D</u>	E	G	H	J	<u>K</u>	L	ØS	I	<u>U</u> °	V	W	X	Y	ØZ	Øp	ØQ	r	s
07	min.	68.94	55.30	63.37	8.23	12.17	57.45	10.46	0.51	5.69	1.05	2.92	2.59	9.0	0	3.81	-	4.5	0.99	1.10	1.45	1.85	2.40
	max.	69.70	55.55	63.63	8.48	12.93	57.96	10.97	1.24	6.13	1.78	3.20	2.69	11.0	0.6	-	22	-	1.04	1.15	1.51	2.15	-
08	min.	68.94	54.71	63.37	7.77	12.17	57.45	10.46	0.51	5.87	0.89	2.92	2.46	9.0	-	3.63	-	4.5	1.07	1.10	1.45	1.85	2.40
	max.	69.70	54.97	63.63	8.03	12.93	57.96	10.97	1.02	6.30	1.52	3.20	2.62	11.0	-	-	22	-	1.14	1.15	1.51	2.15	-

FIGURE 2 - PHYSICAL DIMENSIONS

FIGURE 2(a) - RECEPTACLES AND PLUGS

VARIANTS 09, 10 - SHELL SIZE D

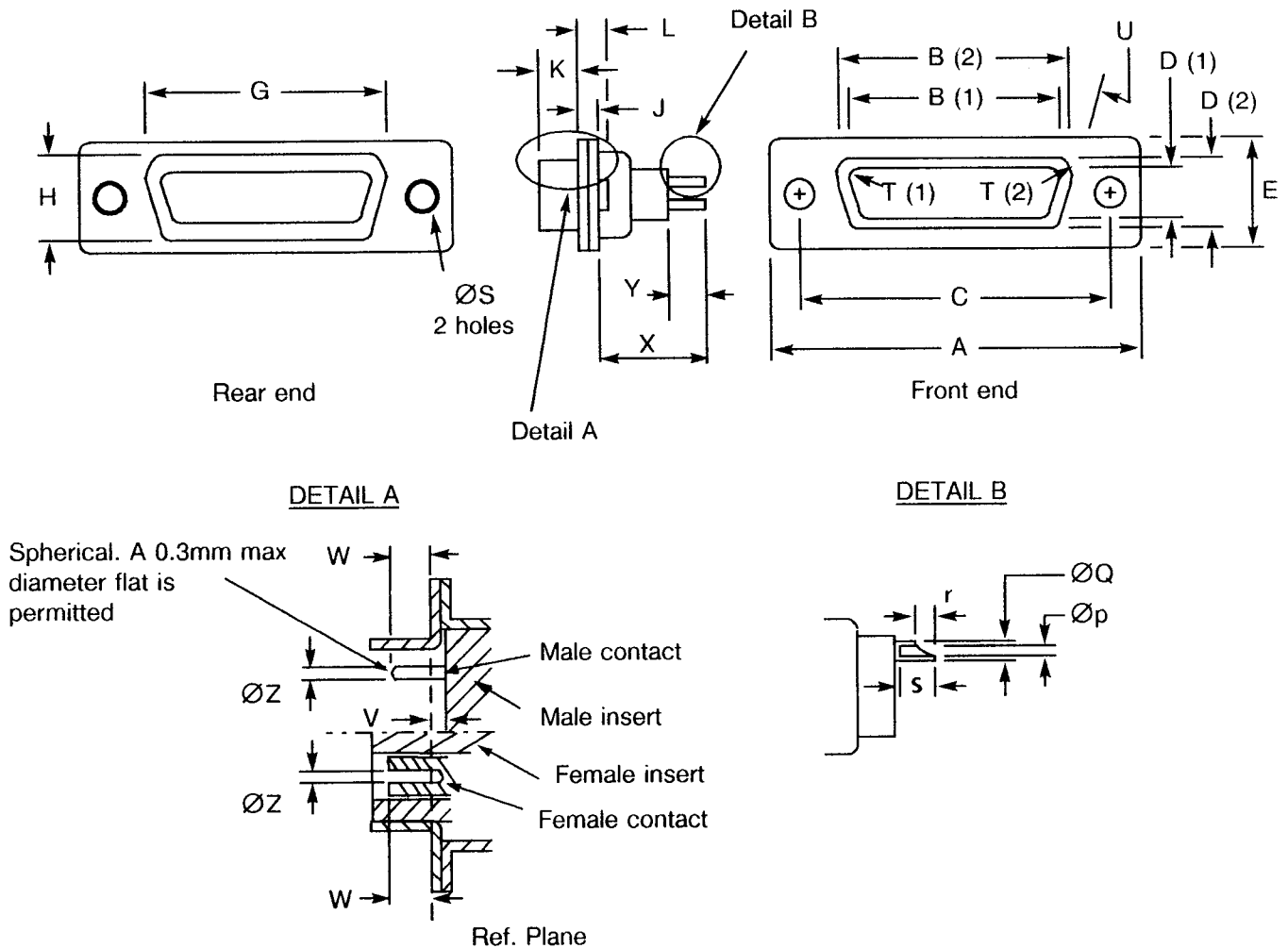

NOTES

1. Inside dimension for connectors with male contacts.
2. Outside dimension for connectors with female contacts.
3. All dimensions are in millimetres (angles in degrees).
4. Underlined dimensions, in table, are critical to ensure intermateability.

Variants	Symbol/ Dim.	<u>A</u>	<u>B</u>	<u>C</u>	<u>D</u>	<u>E</u>	<u>G</u>	<u>H</u>	<u>J</u>	<u>K</u>	<u>L</u>	ØS	<u>I</u>	<u>U</u> °	<u>V</u>	<u>W</u>	<u>X</u>	<u>Y</u>	Ø <u>Z</u>	Øp	ØQ	r	s
09	min.	66.55	52.68	60.99	10.95	14.99	55.07	13.31	0.51	5.69	1.05	2.92	2.59	9.0	0	3.81	-	4.5	0.99	1.10	1.45	1.85	2.40
	max.	67.31	52.93	61.24	11.33	15.75	55.58	13.82	1.24	6.13	1.78	3.20	2.69	11.0	0.6	-	22	-	1.04	1.15	1.51	2.15	-
10	min.	66.55	52.30	60.99	10.62	14.99	55.07	13.31	0.51	5.87	0.89	2.92	2.46	9.0	-	3.63	-	4.5	1.07	1.10	1.45	1.85	2.40
	max.	67.31	52.55	61.24	10.87	15.75	55.58	13.82	1.02	6.30	1.52	3.20	2.62	11.0	-	-	22	-	1.14	1.15	1.51	2.15	-

FIGURE 2 - PHYSICAL DIMENSIONS (CONTINUED)

FIGURE 2(b) - CONTACT ARRANGEMENTS
FRONT VIEW MALE INSERT

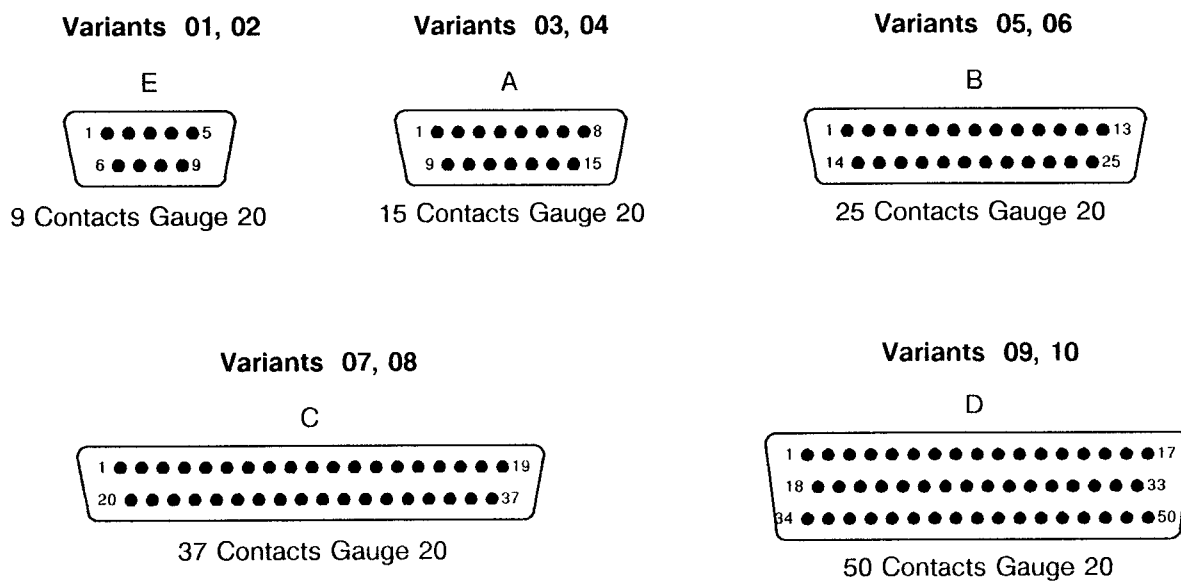

NOTES

1. Contact locations are in conformity with MIL-C-24308 specification sheets and shall not be checked during procurement.
2. Both sides of inserts shall be marked with the minimum marking shown.

FIGURE 3 - CONTACT FUNCTIONAL DIAGRAMS

FILTER TYPE L

Equivalent Circuit for Low Frequency
Filter Contacts

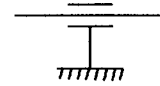

FILTER TYPES M, S AND H

Equivalent Circuit for Medium, Standard and
High Frequency Filter Contacts

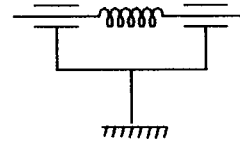

FILTER TYPE NF

Equivalent Circuit for Non-Filtered Contact



FILTER TYPE G

Equivalent Circuit for Grounded Contact

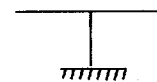

	<p style="text-align: center;">ESA/SCC Detail Specification No. 3405/001</p>		<p>PAGE 18 ISSUE 1</p>
--	--	--	----------------------------

2. APPLICABLE DOCUMENTS

The following documents form part of this specification and shall be read in conjunction with it:-

- (a) ESA/SCC Generic Specification No. 3405 for Connectors, Electrical, Filtered, Circular and Rectangular.
- (b) ESA/SCC Detail Specification No. 3401/022, Accessories for Rectangular Connectors 3401/001, 3401/002 and Connector Savers 3401/020.
- (c) QQ-B-613, Brass Material.
- (d) MIL-G-45204, Gold Plating, Electro-deposited.
- (e) MIL-C-14550, Copper Plating, Electro-deposited.
- (f) MIL-P-19833, Glass, Fibre-filled Diallyl Phthalate Resin.
- (g) MIL-C-24308, Rack and Panel Connectors, Miniature.
- (h) MIL-M-14, Moulding Plastics and Moulded Plastic Parts, Thermosetting.

3. TERMS, DEFINITIONS, ABBREVIATIONS, SYMBOLS AND UNITS

For the purpose of this specification, the terms, definitions, abbreviations, symbols and units specified in ESA/SCC Basic Specification No. 21300 shall apply.

4. REQUIREMENTS

4.1 GENERAL

The complete requirements for procurement of the connectors specified herein are stated in this specification and ESA/SCC Generic Specification No. 3405. Deviations from the Generic Specification, applicable to this specification only, are listed in Para. 4.2.

Deviations from the applicable Generic Specification and this Detail Specification, formally agreed with specific Manufacturers on the basis that the alternative requirements are equivalent to the ESA/SCC requirements and do not affect the components' reliability, are listed in the appendices attached to this specification.

4.2 DEVIATIONS FROM GENERIC SPECIFICATION

4.2.1 Deviations from Special In-process Controls

- (a) Para. 5.2.2: Operating Life Test for Filter Elements, not applicable to non-filtered and grounded contacts.

4.2.2 Deviations from Final Production Tests (Chart II)

None.

4.2.3 Deviations from Burn-in and Electrical Measurements (Chart III)

- (a) Para. 9.3.2: Parameter Drift Values, Not applicable to non-filtered and grounded contacts.
- (b) Para. 9.3.3: Electrical Measurements at High and Low Temperatures, Not applicable to non-filtered and grounded contacts.
- (c) Para. 9.6: Burn-in, Not applicable to non-filtered and grounded contacts.

4.2.4 Deviations from Qualification Tests (Chart IV)

(a) Para. 9.21: Operating life, Not applicable to non-filtered and grounded contacts.

4.2.5 Deviations from Lot Acceptance Tests (Chart V)

(a) Para. 9.21: Operating life, Not applicable to non-filtered and grounded contacts.

4.3 MECHANICAL REQUIREMENTS

4.3.1 Dimension Check

The dimensions of the connectors specified herein shall be verified in accordance with the requirements set out in Para. 9.4 of ESA/SCC Generic Specification 3405 and shall conform to those shown in Figure 2 of this specification.

4.3.2 Weight

The maximum weight of the connectors specified herein, with contacts, shall be as specified in Table 1(a).

4.3.3 Contact Capability

For the purpose of this test, the pick-up and drop weights shall be as follows:-

	PICK-UP WEIGHT	DROP WEIGHT
Weight (g)	28.35	226.80
Pin diameter (mm)	0.990 - 0.993	1.039 - 1.040
Insertion depth (mm)	4.0	4.0

4.3.4 Contact Retention (in Insert)

The contact retention force within the insert shall be 40N.

4.3.5 Mating and Unmating Forces

The forces applied for mating and unmating of the connectors shall conform to the values specified in Table 1(a).



4.3.6 Insert Retention (In Shell)

Connector inserts shall withstand a pressure of 42.8N/cm² without being dislodged from the shell.

4.3.7 Engagement and Separation Forces

The engagement and separation forces of the female contacts shall be tested with the applicable test pin and shall not exceed the values of the table hereunder.

	DIAMETER (mm)		ENGAGEMENT MAX (N)	SEPARATION (N)	
	MIN	MAX		MIN	MAX
Max Ø Test Pin	1.039	1.040	3.33	-	2.22
Min Ø Test Pin	0.990	0.993	-	0.28	-

 	<p style="text-align: center;">ESA/SCC Detail Specification No. 3405/001</p>		<p style="text-align: right;">PAGE 20 ISSUE 1</p>
---	--	--	---

4.3.8 Oversize Pin Exclusion

The diameter of the test pin shall be 1.166mm min. and 1.170mm max., and the force applied to it shall be 3.33N.

4.3.9 Probe Damage

The probe diameter shall be 1.007mm min. and 1.033mm max., and the moment at the end of the probe shall be 5.65N.cm.

4.3.10 Solderability

Size A soldering iron shall be used.

4.4 MATERIALS AND FINISHES

The materials and finishes shall be as specified herein. Where a definite material is not specified, a material which will enable the connectors specified herein to meet the performance requirements of this specification shall be used. Acceptance or approval of any constituent material does not guarantee acceptance of the finished product.

4.4.1 Shells

Shells shall be made of brass in accordance with QQ-B-613, Composition II. They shall be plated as specified in MIL-G-45204, Type II, Grade 'C' Class 1, gold over copper in accordance with MIL-C-14550.

Gold plating thickness shall be 1.27µm minimum over 1.0µm minimum of copper.

4.4.2 Inserts

Inserts shall be made of glass-fibre filled diallylphthalate resin in accordance with MIL-P-19833, Type GDI-30 or GDI-30-F or in accordance with MIL-M-14, Type SGDF.

4.4.3 Contacts

4.4.3.1 Body

The contact body shall be made of copper alloy. The contacts shall be gold-plated as specified in MIL-G-45204, Type II, Grade C, Class 1, thickness 1.27µm minimum over 2.0µm minimum of nickel.

The minimum plating thickness in the solder bucket shall be 0.2µm gold over 0.8µm nickel.

4.4.3.2 Filter

- Capacitor: Ceramic dielectric.
- Ferrite: Sintered iron oxide.

4.4.4 Ground Plane

Ground plane shall be made of copper alloy, gold plated. Gold plating thickness shall be 2.5µm minimum over 1.0µm minimum of copper.

4.4.5 Guiding and Locking Devices

As specified in ESA/SCC Detail Specification No. 3401/022.

4.5 MARKING

4.5.1 General

The marking of all components delivered to this specification shall be in accordance with the requirements of ESA/SCC Basic Specification No. 21700. Each component shall be marked in respect of:-

- (a) Contact Identification.
- (b) The SCC Component Number.
- (c) Characteristics.
- (d) Traceability Information.

4.5.2 Contact Identification

Contact identification shall be marked in accordance with Figure 2.

4.5.3 The SCC Component Number

Each component shall bear the SCC Component Number which shall be constituted and marked as follows:

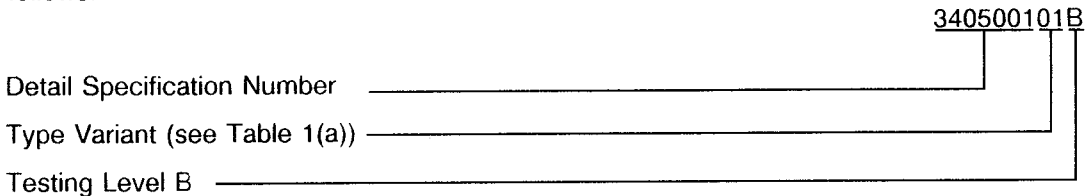

4.5.4 Characteristics

The characteristics to be marked shall consist of filter arrangements as specified in Table 1(a). The information shall be constituted and marked as follows:-

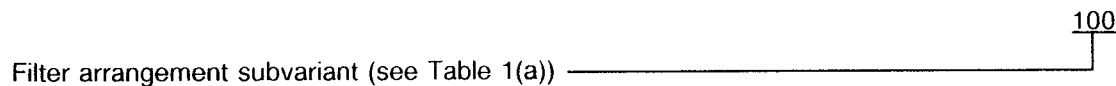

4.5.5 Traceability Information

Traceability information shall be marked in accordance with the requirements of ESA/SCC Basic Specification No. 21700.

4.6 ELECTRICAL MEASUREMENTS

4.6.1 Electrical Measurements at Room Temperature

The parameters to be measured in respect of electrical characteristics are scheduled in Table 2. Unless otherwise specified, these measurements shall be performed at $T_{amb} = +22 \pm 3 \text{ }^\circ\text{C}$.

4.6.2 Electrical Measurements at High and Low Temperatures (Table 3)

The parameters to be measured at high and low temperatures are scheduled in Table 3.

4.6.3 Circuit for Electrical Measurements (Figure 4)

Not applicable.

	ESA/SCC Detail Specification No. 3405/001		PAGE 22 ISSUE 1
---	--	--	--------------------

4.7 BURN-IN AND ELECTRICAL MEASUREMENTS (TABLES 4 AND 5)

4.7.1 Parameter Drift Values

The parameter drift values applicable to burn-in are specified in Table 4 of this specification. Unless otherwise stated, measurements shall be performed at $T_{amb} = +22 \pm 3$ °C. The parameter drift values (Δ) applicable to the scheduled parameters shall not be exceeded. In addition to these drift value requirements for a given parameter, the appropriate limit value specified in Table 2 shall not be exceeded.

4.7.2 Conditions for Burn-in

The requirements for burn-in are specified in Section 7 of ESA/SCC Generic Specification No. 3405. The conditions for burn-in shall be as specified in Table 5 of this specification.

4.7.3 Electrical Circuits for Burn-in

Not applicable.

TABLE 2 - ELECTRICAL MEASUREMENTS AT ROOM TEMPERATURE

No.	Characteristic	Symbol	Spec. and/or Test Method	Limits						UNIT
				Grounded	Non Filtered	Low Freq.	Med Freq.	Std Freq.	High Freq.	
1	Insulation Resistance	R_i min.	ESA/SCC 3405 Para. 9.3.1.1	-	5000 (1)	5000 (2)	10000 (2)	10000 (2)	10000 (2)	$M\Omega$
2	Voltage Proof	V_p min.	ESA/SCC 3405 Para. 9.3.1.2 $I_L = 500 \mu A$	-	1250	300	500	500	500	Vdc
3	Mated Shell Conductivity (Voltage Drop)	V_d max.	ESA/SCC 3405 Para. 9.3.1.4	N o t a p p l i c a b l e						mV
4	Contact Resistance (Low Level Current)	R_{cl} max.	ESA/SCC 3405 Para. 9.3.1.3	6.0	6.0	8.5	8.5	8.5	8.5	$m\Omega$
5	Contact Resistance (Rated Current)	R_{cr} max.	ESA/SCC 3405 Para. 9.3.1.3	-	5.0	6.0	6.0	6.0	6.0	$m\Omega$
6	Ground Resistance	R_{cg}	ESA/SCC 3405 Para. 9.3.1.5	3.0	-	-	-	-	-	$m\Omega$
7	Capacitance	C min. C max.	ESA/SCC 3405 Para. 9.3.1.6 <u>CONDITION:</u> 0.1Vrms/1KHz 0.1Vrms/1KHz	-	-	50000	4000	2300	500	pF
8	Insertion Loss (no applied current or voltage)	I_L min.	ESA/SCC 3405 Para. 9.3.1.7 <u>CONDITION:</u> 1.0MHz 2.0MHz 10MHz 30MHz 100MHz 500MHz 1000MHz	-	-	13 (3) 19 30 (3) 40 45 (3) -	2 (3) 5 13 (3) 28 50 (3) -	- 2 (3) 8 20 (3) 41 55 (3) -	- - 2 (3) 8 25 (3) 45 50 (3)	dB

NOTES

1. 500Vdc applied.
2. 100Vdc applied.
3. Values to be measured during Charts II, III and V testing.

**TABLE 3 - ELECTRICAL MEASUREMENTS AT HIGH AND LOW TEMPERATURES (1)**

No.	Characteristic	Symbol	Spec. and/or Test Method	Test Conditions	Filter	Limits		Unit
						Min.	Max.	
1	Insulation Resistance	R _i	ESA/SCC 3405 Para. 9.3.1.1	T _{amb} = +125(+0 - 5)°C V = 100Vdc	Low Freq.	50	-	MΩ
					Med. Freq.	50	-	
					Std. Freq.	1000	-	
					High Freq.	1000	-	
				T _{amb} = -55(+5 - 0)°C V = 100Vdc	Low Freq.	5000	-	
					Med. Freq.	5000	-	
					Std. Freq.	10000	-	
					High Freq.	10000	-	

NOTES

- Not applicable to non-filtered and grounded contacts.

TABLE 4 - PARAMETER DRIFT VALUES (1)

No.	Characteristics	Symbol	Spec. and/or Test Method	Test Conditions	Change Limits	Unit
1	Insulation Resistance Drift	$\frac{\Delta R_i}{R_i}$	As per Table 2	As per Table 2	- 50	%
7	Capacitance Drift	$\frac{\Delta C}{C}$	As per Table 2	As per Table 2	± 20	%

NOTES

- Not applicable to non-filtered and grounded contacts.

TABLE 5 - CONDITIONS FOR BURN-IN AND OPERATING LIFE TEST (1)

No.	CHARACTERISTICS	SYMBOL	CONDITION	UNIT
1	Ambient Temperature	T_{amb}	+ 125(+ 0 – 3)	°C
2	Voltage (2)	V_T	See Table 1(b)	Vdc

NOTES

1. Not applicable to non-filtered and grounded contacts.
2. Applied between contact and ground.

4.8 ENVIRONMENTAL AND ENDURANCE TESTS

4.8.1 Measurements and Inspections on Completion of Environmental Tests

The parameters to be measured and inspections to be performed on completion of environmental testing shall be those specified in Table 6. Unless otherwise specified, the measurements shall be performed at $T_{amb} = +22 \pm 3$ °C.

4.8.2 Measurements and Inspections at Intermediate Points during Endurance Tests

The parameters to be measured and inspections to be performed at intermediate points during endurance tests are scheduled in Table 6. Unless otherwise specified, measurements shall be performed at $T_{amb} = +22 \pm 3$ °C.

4.8.3 Measurements and Inspections on Completion of Endurance Tests

The parameters to be measured and inspections to be performed on completion of endurance tests shall be those specified in Table 6. Unless otherwise specified, the measurements shall be performed at $T_{amb} = +22 \pm 3$ °C.

4.8.4 Conditions for Operating Life Test (Part of Endurance Testing)

As per Table 5.

4.8.5 Electrical Circuits for Operating Life Test

Not applicable.

4.8.6 Conditions for High Temperature Storage Test (Part of Endurance Testing)

The requirements for the high temperature storage test are specified in Section 9 of ESA/SCC Generic Specification No. 3405. The conditions for high temperature storage testing shall be the maximum storage temperature specified in Table 1(b) of this specification.

TABLE 6 - MEASUREMENTS AND INSPECTIONS ON COMPLETION OF ENVIRONMENTAL TESTS AND AT INTERMEDIATE POINTS AND ON COMPLETION OF ENDURANCE TESTS

NO.	ESA/SCC GENERIC NO. 3405		MEASUREMENTS AND INSPECTIONS		SYMBOL	LIMITS		UNIT	
	ENVIRONMENTAL AND ENDURANCE TESTS (1)	TEST METHOD AND CONDITIONS	IDENTIFICATION	CONDITIONS		MIN	MAX		
01	Wiring	Para. 9.10	Insertion Loss	Table 2 Item 8	IL	Table 2 Item 8			
02	Vibration	Para. 9.11	Initial Coupling Screw(s) Unlocking Torque	-	-	Record Values			
			Final Coupling Screw(s) Unlocking Torque Drift Visual Examination	-	Δ	-25	+ 25	%	
03	Shock or Bump	Para. 9.12	Visual Examination	-		-	-		
04	Climatic Sequence	Para. 9.13	Low Air Pressure Voltage Proof	Figure 1 Immediately after test Table 2 Item 1	Vp	ESA/SCC 3405 Para. 9.13.5			
			Damp Heat Insulation Resistance		Ri	1/10 of Table 3 values			
			Final External Visual Inspection	After 1-24 hrs Recovery ESA/SCC 3405 Para. 9.5			ESA/SCC 3405 Para. 9.5		
			Insertion Loss	Table 2 Item 8	IL	Table 2 Item 8			
			Capacitance	Table 2 Item 7	C	Table 2 Item 7			
			Insulation Resistance	Table 2 Item 1	Ri	Table 2 Item 1			
			Voltage Proof	Table 2 Item 2	Vp	Table 2 Item 2			
05	Rapid Change of Temperature	Para. 9.9.3	Visual Examination	-	-	-	-		
			Insertion Loss	Table 2 Item 8	IL	Table 2 Item 8			
			Capacitance	Table 2 Item 7	C	Table 2 Item 7			
			Insulation Resistance	Table 2 Item 1	Ri	Table 2 Item 1			
			Voltage Proof	Table 2 Item 2	Vp	Table 2 Item 2			
06	Contact Retention in Insert	Para. 9.14 & Para. 4.3.4 of this spec.	Contact displacement			ESA/SCC 3405 Para. 9.14			

NOTES

1. The tests in this table refer to either Chart IV or V and shall be used as applicable.



SCC

ESA/SCC Detail Specification
No. 3405/001

Rev. 'A'

PAGE 27

ISSUE 1

TABLE 6 - MEASUREMENTS AND INSPECTIONS ON COMPLETION OF ENVIRONMENTAL TESTS AND AT INTERMEDIATE POINTS AND ON COMPLETION OF ENDURANCE TESTS (CONT'D)

NO.	ESA/SCC GENERIC NO. 3405		MEASUREMENTS AND INSPECTIONS		SYMBOL	LIMITS		UNIT
	ENVIRONMENTAL AND ENDURANCE TESTS (1)	TEST METHOD AND CONDITIONS	IDENTIFICATION	CONDITIONS		MIN	MAX	
07	Endurance	Para. 9.15	Initial Mating/Unmating Forces Low Level Contact Resis. Ground Resistance Mated Shell Conductivity Capacitance Insulation Resistance Final Visual Examination Mating/Unmating Forces Low Level Contact Resistance Drift Ground Resistance Mated Shell Conductivity Insertion Loss Capacitance Drift Insulation Resistance Drift Voltage Proof	- Table 2 Item 4 Table 2 Item 6 Table 2 Item 3 Table 2 Item 7 Table 2 Item 1 - - Table 2 Item 4 Table 2 Item 6 Table 2 Item 3 Table 2 Item 5 Table 2 Item 7 Table 2 Item 1 Table 2 Item 2	- Rcl Rcg Vd C Ri - - ΔRcl Rcg Vd IL ΔC/C ΔRi/Ri Vp	Para. 4.3.5 of this spec Record Values Table 2 Item 6 Table 2 Item 3 Table 2 Item 7 Table 2 Item 1 - - Para. 4.3.5 of this spec - 3.0	mΩ	
08	Permanence of Marking	Para. 9.16	As applicable					
09	Mating/Unmating Forces	Para. 9.17	Force				Para. 4.3.5 of this spec	
10	High Temperature Storage	Para. 9.18	Initial Low Level Contact Resis. Ground Resistance Mated Shell Conductivity Capacitance Insulation Resistance Final Visual Examination Mating/Unmating Forces Low Level Contact Resistance Drift Ground Resistance Mated Shell Conductivity Insertion Loss Capacitance Drift Insulation Resistance Drift Voltage Proof Contact Retention in Insert	Table 2 Item 4 Table 2 Item 6 Table 2 Item 3 Table 2 Item 7 Table 2 Item 1 - - Table 2 Item 4 Table 2 Item 6 Table 2 Item 3 Table 2 Item 8 Table 2 Item 7 Table 2 Item 1 Table 2 Item 2 Para. 4.3.4 of this spec	Rcl Rcg Vd C Ri - - ΔRcl Rcg Vd IL ΔC/C ΔRi/Ri Vp	Record Values Table 2 Item 6 Table 2 Item 3 Table 2 Item 7 Table 2 Item 1 - - Para. 4.3.5 of this spec - 3.0 Para. 4.3.4	mΩ	

NOTES

1. The tests in this table refer to either Chart IV or V and shall be used as applicable.



TABLE 6 - MEASUREMENTS AND INSPECTIONS ON COMPLETION OF ENVIRONMENTAL TESTS AND AT INTERMEDIATE POINTS AND ON COMPLETION OF ENDURANCE TESTS (CONT'D)

NO.	ESA/SCC GENERIC NO. 3405		MEASUREMENTS AND INSPECTIONS		SYMBOL	LIMITS		UNIT
	ENVIRONMENTAL AND ENDURANCE TESTS (1)	TEST METHOD AND CONDITIONS	IDENTIFICATION	CONDITIONS		MIN	MAX	
11	Corrosion	Para. 9.19	Visual Examination	-	-	-	-	
12	Insert Retention in Shell	Para. 9.20 & Para. 4.3.6 of this spec.	Visual Examination	-	-	Para. 4.3.6		
13	Operating Life	Para. 9.21	Initial Capacitance Insulation Resistance Intermediate and Final Insul. Resist. After 24hrs Max. Recovery Insertion Loss Capacitance Drift Insulation Resistance Drift Voltage Proof	Table 2 Item 7 Table 2 Item 1 Table 3 Item 1 Table 2 Item 8 Table 2 Item 7 Table 2 Item 1 90% of Table 2 Item 2	C Ri Ri IL $\Delta C/C$ $\Delta Ri/Ri$ Vp	Table 2 Item 7 Table 2 Item 1 Table 3 Item 1 Table 2 Item 8 Table 4 Item 7 Table 4 Item 1 Table 2 Item 2		
14	Resistance to Soldering Heat	Para. 9.22	After 1-2 hrs recovery Visual Examination Insulation Resistance Insertion Loss	- Table 2 Item 1 Table 2 Item 8	- Ri IL	- Table 2 Item 1 Table 2 Item 8		
15	Engage/Separation Forces	Para. 9.23 & Para. 4.3.7 of this spec.	Force	-	-	Para. 4.3.7		
16	Oversize Pin Exclusion	Para. 9.24 & Para. 4.3.8 of this spec.	-	-	-	ESA/SCC 3405 Para. 9.24		
17	Probe Damage	Para. 9.25 & Para. 4.3.9 of this spec.	Contact Separation Force	Para. 4.3.7 of this spec	-	Para. 4.3.7		
18	Solderability	Para. 9.26 & Para. 4.3.10 of this spec.	-	-	-	ESA/SCC 3405 Para. 9.26		
19	Pin Bending Test	Para. 9.27	Visual Examination Capacitance Drift Insulation Resistance Drift	- Table 2 Item 7 Table 2 Item 1	- ΔC ΔRi	- Table 4 Item 7 Table 4 Item 1		

NOTES 1. The tests in this table refer to either Chart IV or V and shall be used as applicable.



TABLE 6 - MEASUREMENTS AND INSPECTIONS ON COMPLETION OF ENVIRONMENTAL TESTS AND AT INTERMEDIATE POINTS AND ON COMPLETION OF ENDURANCE TESTS (CONT'D)

NO.	ESA/SCC GENERIC NO. 3405		MEASUREMENTS AND INSPECTIONS		SYMBOL	LIMITS		UNIT
	ENVIRONMENTAL AND ENDURANCE TESTS (1)	TEST METHOD AND CONDITIONS	IDENTIFICATION	CONDITIONS		MIN	MAX	
20	Plating Thickness	Para. 9.28	Thickness	-		Para. 4.4.3.1 of this spec		
21	External Visual Inspection	Para. 9.5	External Visual Inspection	ESA/SCC 3405 Para. 9.5	-	ESA/SCC 3405 Para. 9.5		
22	Contact Capability	Para. 9.2 & Para. 4.3.3 of this spec.	Go-No go Weights	-	-	ESA/SCC 3405 Para. 9.2		
23	Mating Verification	Para. 9.8	-	-	-	ESA/SCC 3405 Para. 9.8		

NOTES 1. The tests in this table refer to either Chart IV or V and shall be used as applicable.