



Pages 1 to 39

**CONNECTORS, ELECTRICAL, RECTANGULAR,  
MICROMINIATURE,**

**BASED ON TYPE MDM**

**ESCC Detail Specification No. 3401/029**

Issue 7	January 2012
---------	--------------



Document Custodian: European Space Agency - see <https://escies.org>

### **LEGAL DISCLAIMER AND COPYRIGHT**

European Space Agency, Copyright © 2012. All rights reserved.

The European Space Agency disclaims any liability or responsibility, to any person or entity, with respect to any loss or damage caused, or alleged to be caused, directly or indirectly by the use and application of this ESCC publication.

This publication, without the prior permission of the European Space Agency and provided that it is not used for a commercial purpose, may be:

- copied in whole, in any medium, without alteration or modification.
- copied in part, in any medium, provided that the ESCC document identification, comprising the ESCC symbol, document number and document issue, is removed.

**DOCUMENTATION CHANGE NOTICE**

(Refer to <https://escies.org> for ESCC DCR content)

DCR No.	CHANGE DESCRIPTION
665	Specification upissued to incorporate editorial and technical changes per DCR.

**TABLE OF CONTENTS**

<b>1.</b>	<b><u>GENERAL</u></b>	<b><u>6</u></b>
1.1	Scope	6
1.2	Range of Components	6
1.3	Maximum Ratings	6
1.4	Parameter Derating Information	6
1.5	Physical Dimensions	6
1.6	Contact Arrangements	6
<b>2.</b>	<b><u>APPLICABLE DOCUMENTS</u></b>	<b><u>6</u></b>
<b>3.</b>	<b><u>TERMS, DEFINITIONS, ABBREVIATIONS, SYMBOLS AND UNITS</u></b>	<b><u>7</u></b>
<b>4.</b>	<b><u>REQUIREMENTS</u></b>	<b><u>28</u></b>
4.1	General	28
4.2	Deviations from Generic Specification	29
4.2.1	Deviations from Special In-Process Controls	29
4.2.2	Deviations from Final Production Tests (Chart II)	29
4.2.3	Deviations from Burn-in and Electrical Measurements (Chart III)	29
4.2.4	Deviations from Qualification Tests (Chart IV)	29
4.2.5	Deviations from Lot Acceptance Tests (Chart V)	29
4.3	Mechanical Requirements	29
4.3.1	Dimension Check	29
4.3.2	Weight	30
4.3.3	Contact Capability	30
4.3.4	Contact Retention (in Insert)	30
4.3.5	Mating and Unmating Forces	30
4.3.6	Insert Retention (in Shell)	30
4.3.7	Jackscrew Retention	30
4.3.8	Contact Insertion and Withdrawal Forces	30
4.3.9	Engagement and Separation Forces (Male Contacts)	30
4.3.10	Oversize Pin Exclusion	30
4.3.11	Probe Damage	31
4.3.12	Solderability	31
4.4	Materials and Finishes	31
4.4.1	Shells	31
4.4.2	Inserts	31
4.4.3	Contacts	31
4.4.3.1	Female Contacts	31
4.4.3.2	Male Contacts	31
4.4.4	Interfacial Seals	31
4.4.5	Insulated Wires	31
4.4.6	Uninsulated Solid Wire	31
4.4.7	Rear Potting	31
4.5	Marking	32
4.5.1	General	32
4.5.2	The ESCC Component Number	32
4.5.3	Characteristics	32
4.5.3.1	Shell Size	32
4.5.3.2	Contact Type	33
4.5.3.3	Termination Type	33
4.5.3.4	Mounting	33
4.5.4	Traceability Information	33
4.6	Electrical Measurements	34

4.6.1	Electrical Measurements at Room Temperature	34
4.6.2	Electrical Measurements at High and Low Temperatures	34
4.6.3	Circuits for Electrical Measurements	34
4.7	Burn-in and Electrical Measurements (Tables 4 and 5)	34
4.8	Environmental and Endurance Tests (Charts IV and V of ESCC Generic Specification No. 3401)	36
4.8.1	Measurements and Inspections on Completion of Environmental Tests	36
4.8.2	Measurements and Inspections at Intermediate Points during Endurance Tests	36
4.8.3	Measurements and Inspections on Completion of Endurance Tests	36
4.8.4	Conditions for Operating Life Test (Part of Endurance Testing)	36
4.8.5	Electrical Circuit for Operating Life Test	36
4.8.6	Conditions for High Temperature Storage Test (Part of Endurance Testing)	36
APPENDIX 'A' - AGREED DEVIATIONS FOR C & K COMPONENTS (F)		39

## 1. GENERAL

### 1.1 SCOPE

This specification details the ratings, physical and electrical characteristics, test and inspection data for Electrical, Rectangular, Microminiature Connectors with Non-Removable Crimp-type Contacts and their associated insulated wires and uninsulated solid wires, based on type MDM.

It shall be read in conjunction with:

- (a) ESCC Generic Specification No. 3401, Connectors, Electrical, Rectangular and Circular.
- (b) ESCC Detail Specification No. 3401/032, Accessories for Connectors, Microminiature, 3401/029, 3401/077 and Connector Savers 3401/041.

the requirements of which are supplemented herein.

### 1.2 RANGE OF COMPONENTS

The different sizes of the basic type connectors specified herein, which are also covered by this specification, together with their mechanical characteristics, are scheduled in Table 1(a). The different sizes of associated insulated wires and uninsulated solid wires are given in Figure 2.

### 1.3 MAXIMUM RATINGS

The maximum ratings, which shall not be exceeded at any time during use or storage, applicable to the connectors specified herein, are given in Table 1(b).

### 1.4 PARAMETER DERATING INFORMATION

The derating information applicable to the contacts specified herein is shown in Figure 1.

### 1.5 PHYSICAL DIMENSIONS

The physical characteristics of the connectors, insulated wires and uninsulated solid wires specified herein are shown in Figure 2.

### 1.6 CONTACT ARRANGEMENTS

Contact arrangements are shown in Figure 3.

## 2. APPLICABLE DOCUMENTS

The following documents form part of this specification and shall be read in conjunction with it:

- (a) ESCC Generic Specification No. 3401, Connectors, Electrical, Circular and Rectangular.
- (b) ESCC Detail Specification No. 3401/032, Accessories for Connectors, Microminiature, 3401/029, 3401/077 and Connector Savers 3401/041.
- (c) ESCC Detail Specification No. 3901/002, Polyimide Insulated Wires and Cables, Low Frequency, 600V, -100 to +200°C.
- (d) ESCC Detail Specification No. 3901/013, PTFE Insulated Wires and Cables, 600V, -100 to +200°C.
- (e) QQ-W-343, Wire, Electrical, Copper (Uninsulated).
- (f) MIL-DTL-45204, Gold Plating, Electro-deposited.
- (g) MIL-C-14550, Copper Plating, Electro-deposited.
- (h) MIL-PRF-83513, Connectors Electrical, Rectangular, Microminiature, Polarised Shell, General

Specification for.

**3. TERMS, DEFINITIONS, ABBREVIATIONS, SYMBOLS AND UNITS**

For the purpose of this specification, the terms, definitions, abbreviations, symbols and units specified in ESCC Basic Specification No. 21300 shall apply.

**TABLE 1(a) - RANGE OF COMPONENTS**

Variants		Shell Size	Weight Max g				Mating Force N Max	Unmating Force	
Shell Finish			FR112 to FR116 FR112A to FR116A FR123 and FR123A (1)	FR136 (2)	FR136A (2)	FR139 (2)		N Max	N Min
Nickel	Gold								
01	02	9	2.2	7.4	7.4	4.6	20	20	1.3
01	02	15	3	7.8	N/A	5	33	33	2
01	02	21	3.8	8.5	N/A	5.4	47	47	2.9
01	02	25	4.3	10.2	N/A	6.5	55	55	3.5
01	02	31	5.1	12.2	N/A	7.7	69	69	4.3
01	02	37	5.9	14.4	N/A	9.2	82	82	5.1
01	02	51	7.2	16.5	N/A	10.5	113	113	7.1

**NOTES:**

1. Connector contacts and rear potting, without cables, without floating eyelets and without captive nut. Add 0.4g for connectors with floating mounts and 1g for connectors with captive nuts. See Figures 2.4 and 2.5 for the weight of cable.
2. Connector with contacts and rear potting.

**TABLE 1(b) - MAXIMUM RATINGS**

No.	Characteristic	Symbol	Maximum Rating	Unit	Remarks
1	Working Voltage Sea Level	$U_R$	150	Vrms	Note 1
2	Rated Current: (AWG26 and uninsulated solid wire)	$I_R$	2.5	A	
3	Rated Current: (AWG28)	$I_R$	1.5	A	
4	Operating Temperature Range	$T_{op}$	-55 to +125	°C	
5	Storage Temperature Range	$T_{stg}$	-55 to +125	°C	

**NOTES:**

1. Between contacts, and contact and shell.

**FIGURE 1 - PARAMETER DERATING INFORMATION**  
**FIGURE 1(a) - WORKING VOLTAGE VERSUS ALTITUDE**

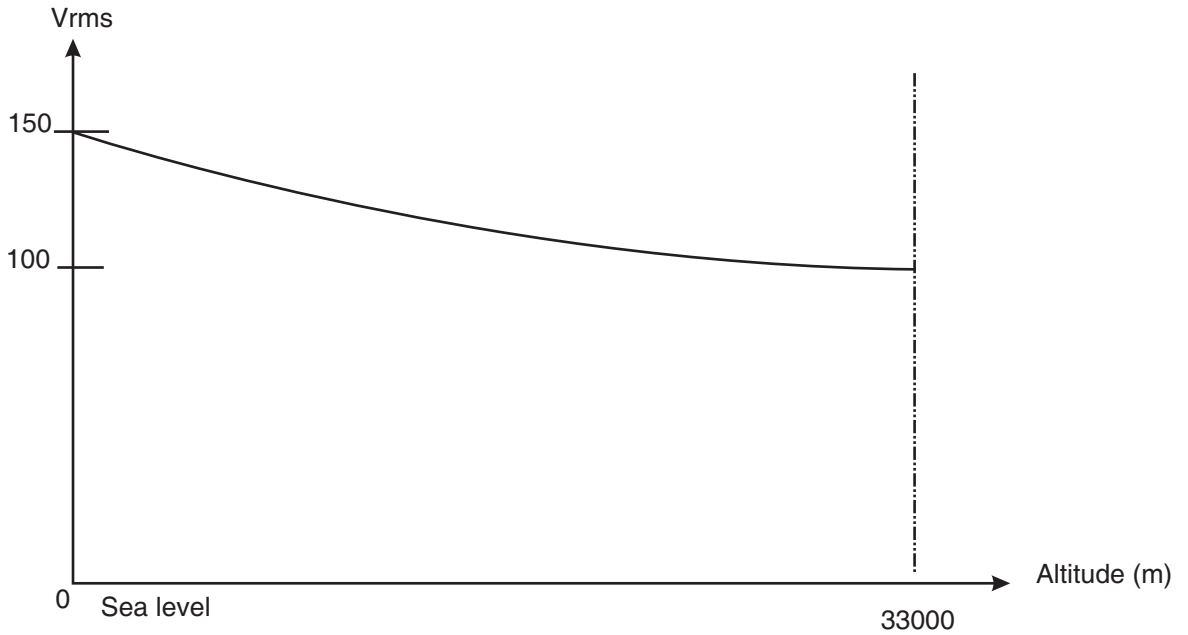

**FIGURE 1(b) - MAXIMUM CURRENT VERSUS NUMBER OF CONTACTS**

NUMBER OF CURRENT-CARRYING CONTACTS PER CONNECTOR	MAXIMUM CURRENT PER CONTACT (A)	
	WIRE SIZE	
	AWG26 AND UNINSULATED SOLID WIRE	AWG 28
2 - 4	2	1.4
5 - 14	1.8	1.2
15 and over	1.4	0.9

**FIGURE 2 - PHYSICAL DIMENSIONS**  
 Figure 2.1A Connector Shells - Plug Male Contacts

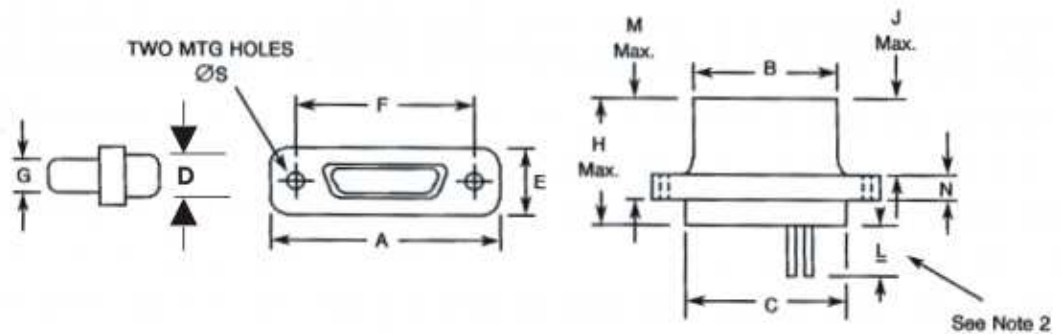



SHELL SIZE	A Max	B Max	C Max	D Max	E Max	E		G Max	H Max	J Max	M Max	N		ØS	
						Min	Max					Min	Max	Min	Max
9	19.94	8.46	10.16	6.86	7.82	14.22	14.48	4.69	10.57	4.72	7.26	2.23	2.49	2.23	2.39
15	23.75	12.27	13.97	6.86	7.82	18.03	18.29	4.69	10.57	4.72	7.26	2.23	2.49	2.23	2.39
21	27.56	16.08	17.78	6.86	7.82	21.84	22.1	4.69	10.57	4.72	7.26	2.23	2.49	2.23	2.39
25	30.1	18.62	20.32	6.86	7.82	24.38	24.64	4.69	10.57	4.72	7.26	2.23	2.49	2.23	2.39
31	33.91	22.43	24.13	6.86	7.82	28.19	28.45	4.69	10.57	4.72	7.26	2.23	2.49	2.23	2.39
37	37.72	26.24	27.94	6.86	7.82	32	32.26	4.69	10.57	4.72	7.26	2.23	2.49	2.23	2.39
51	36.45	24.97	26.67	7.87	8.92	30.73	30.99	5.78	10.57	4.72	7.26	2.23	2.49	2.23	2.39

**NOTES:**

1. All dimensions are in millimetres.
2. For minimum length of L refer to Para. 4.5.3.3 of this specification.

Figure 2.1B Connector Shells - Receptacle Female Contacts

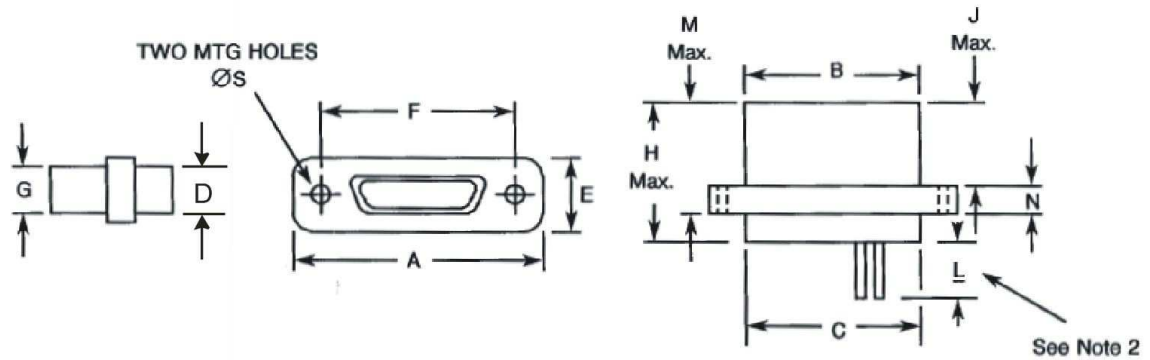

SHELL SIZE	A Max	B Max	C Max	D Max	E Max	E		G Max	H Max	J Max	M Max	N		ØS	
						Min	Max					Min	Max	Min	Max
9	19.94	10.16	10.16	6.86	7.82	14.22	14.48	6.38	10.9	5.05	7.59	2.23	2.49	2.23	2.39
15	23.75	13.97	13.97	6.86	7.82	18.03	18.29	6.38	10.9	5.05	7.59	2.23	2.49	2.23	2.39
21	27.56	17.78	17.78	6.86	7.82	21.84	22.1	6.38	10.9	5.05	7.59	2.23	2.49	2.23	2.39
25	30.1	20.32	20.32	6.86	7.82	24.38	24.64	6.38	10.9	5.05	7.59	2.23	2.49	2.23	2.39
31	33.91	24.13	24.13	6.86	7.82	28.19	28.45	6.38	10.9	5.05	7.59	2.23	2.49	2.23	2.39
37	37.72	27.94	27.94	6.86	7.82	32	32.26	6.38	10.9	5.05	7.59	2.23	2.49	2.23	2.39
51	36.45	26.67	26.67	7.87	8.92	30.73	30.99	7.47	10.9	5.05	7.59	2.23	2.49	2.23	2.39

**NOTES:**

1. All dimensions are in millimetres.
2. For minimum length of L refer to Para. 4.5.3.3 of this specification.

**FIGURE 2.2A - CONNECTORS TYPE - FR136  
PLUG MALE CONTACTS**

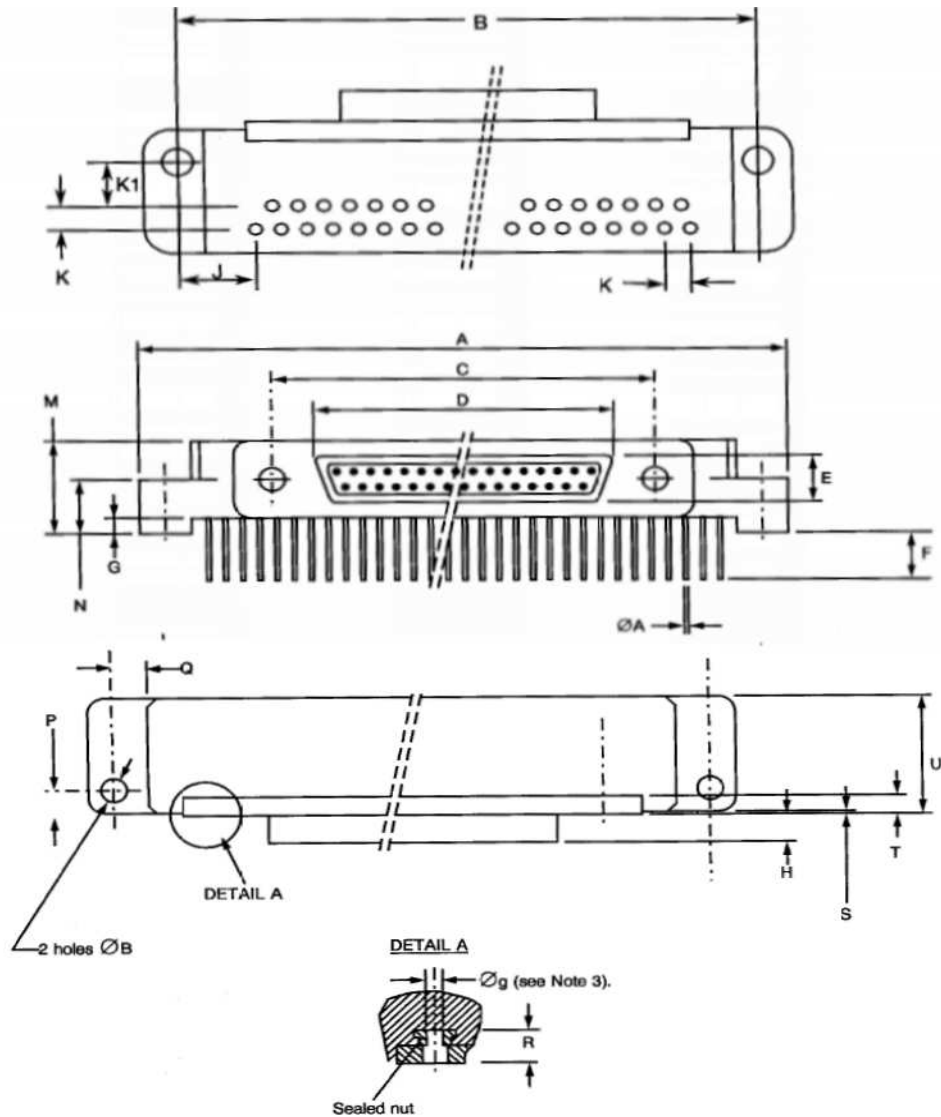

Shell Size	A		B		$\varnothing B$ (4)		C		D	E	F		G		H	J
	Max.	Min.	Max.	Min.	Max.	Min.	Max.	Max.	Max.	Min.	Max.	Min.	Max.	Max.	Typ.	
9	35.31	29.03	29.39	2.31	2.59	14.22	14.48	8.46	4.69	4.15	4.85	1.3	1.7	4.72	9.53	
15	39.12	32.84	33.2	2.31	2.59	18.03	18.29	12.27	4.69	4.15	4.85	1.3	1.7	4.72	7.62	
21	42.93	36.65	37.01	2.31	2.59	21.84	22.1	16.08	4.69	4.15	4.85	1.3	1.7	4.72	5.72	
25	45.47	39.19	39.55	2.31	2.59	24.38	24.64	18.62	4.69	4.15	4.85	1.3	1.7	4.72	4.45	
31	51.82	45.54	45.9	2.31	2.59	28.19	28.45	22.43	4.69	4.15	4.85	1.3	1.7	4.72	3.81	
37	59.44	53.16	53.52	2.31	2.59	32	32.26	26.24	4.69	4.15	4.85	1.3	1.7	4.72	3.81	

Shell Size	K	K1		M		N		P		Q		R	S			T		U
	Max.	Min.	Max.	Min.	Max.	Min.	Max.	Min.	Max.	Min.	Max.	Min.	Min.	Max.	Min.	Max.	Max.	
9	2.54	3.56	4.06	9	9.2	5.15	5.45	2.79	3.55	2	2.1	4.8	0.2	0.4	2.23	2.49	11.56	
15	2.54	3.56	4.06	9	9.2	5.15	5.45	2.79	3.55	2	2.1	4.8	0.2	0.4	2.23	2.49	11.56	
21	2.54	3.56	4.06	9	9.2	5.15	5.45	2.79	3.55	2	2.1	4.8	0.2	0.4	2.23	2.49	11.56	
25	2.54	3.56	4.06	9	9.2	5.15	5.45	2.79	3.55	2	2.1	4.8	0.2	0.4	2.23	2.49	11.56	
31	2.54	3.56	4.06	9	9.2	5.15	5.45	2.79	3.55	2	2.1	4.8	0.2	0.4	2.23	2.49	11.56	
37	2.54	3.56	4.06	9	9.2	5.15	5.45	2.79	3.55	2	2.1	4.8	0.2	0.4	2.23	2.49	11.56	

**NOTES:**

1. All dimensions are in millimetres.
2. For ØA refer to Para. 4.5.3.3 of this specification.
3. Øg: 2-56-UNC-2B.
4. Maximum torque 0.44 Nm.

**FIGURE 2.2B - CONNECTORS TYPE - FR136  
RECEPTACLE FEMALE CONTACTS**

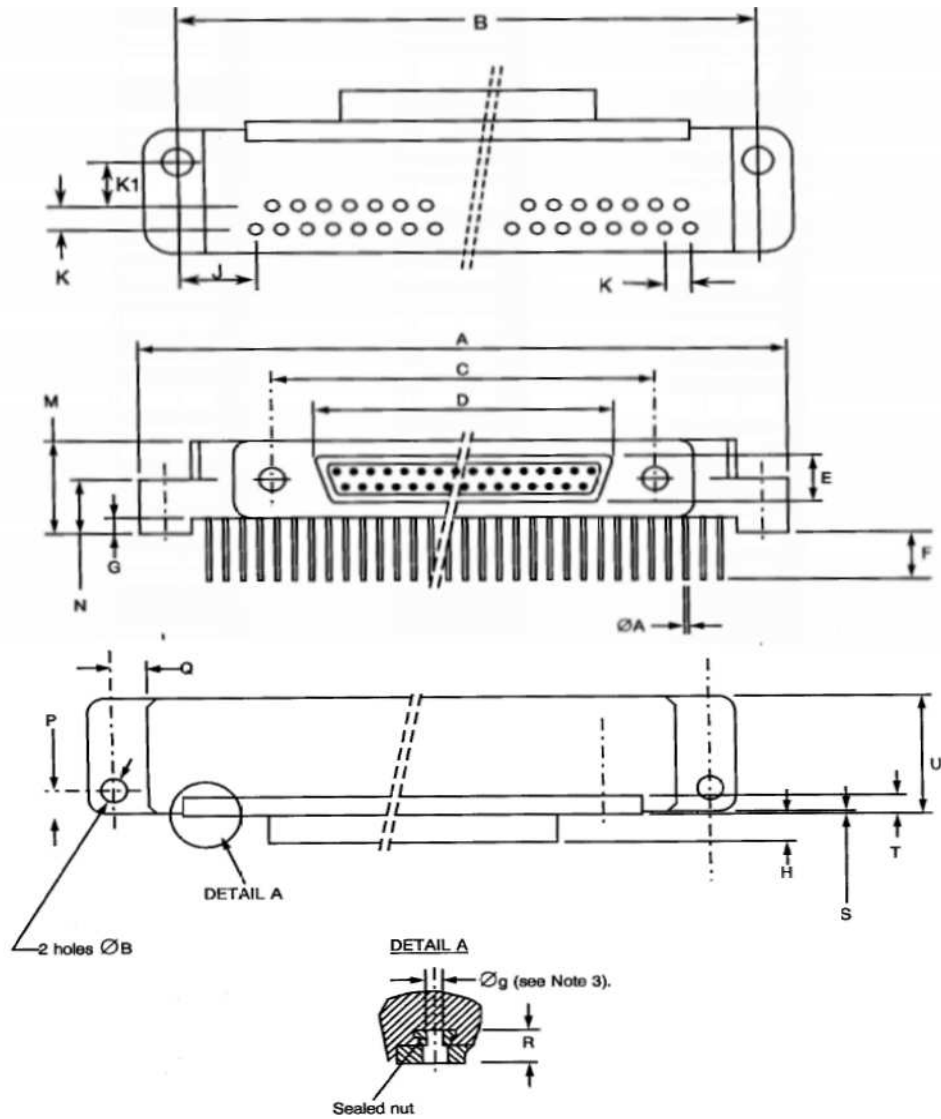

Shell Size	A		B		$\varnothing B$ (4)		C		D	E	F		G		H	J
	Max.	Min.	Max.	Min.	Max.	Min.	Max.	Max.	Max.	Min.	Max.	Min.	Max.	Max.	Typ.	
9	35.31	29.03	29.39	2.31	2.59	14.22	14.48	10.16	6.38	4.15	4.85	1.3	1.7	5.05	9.53	
15	39.12	32.84	33.2	2.31	2.59	18.03	18.29	13.97	6.38	4.15	4.85	1.3	1.7	5.05	7.62	
21	42.93	36.65	37.01	2.31	2.59	21.84	22.1	17.78	6.38	4.15	4.85	1.3	1.7	5.05	5.72	
25	45.47	39.19	39.55	2.31	2.59	24.38	24.64	20.32	6.38	4.15	4.85	1.3	1.7	5.05	4.45	
31	51.82	45.54	45.9	2.31	2.59	28.19	28.45	24.13	6.38	4.15	4.85	1.3	1.7	5.05	3.81	
37	59.44	53.16	53.52	2.31	2.59	32	32.26	27.94	6.38	4.15	4.85	1.3	1.7	5.05	3.81	

Shell Size	K	K1		M		N		P		Q		R	S			T		U
	Max.	Min.	Max.	Min.	Max.	Min.	Max.	Min.	Max.	Min.	Max.	Min.	Min.	Max.	Min.	Max.	Max.	
9	2.54	3.56	4.06	9	9.2	5.15	5.45	2.79	3.55	2	2.1	4.8	0.2	0.4	2.23	2.49	11.56	
15	2.54	3.56	4.06	9	9.2	5.15	5.45	2.79	3.55	2	2.1	4.8	0.2	0.4	2.23	2.49	11.56	
21	2.54	3.56	4.06	9	9.2	5.15	5.45	2.79	3.55	2	2.1	4.8	0.2	0.4	2.23	2.49	11.56	
25	2.54	3.56	4.06	9	9.2	5.15	5.45	2.79	3.55	2	2.1	4.8	0.2	0.4	2.23	2.49	11.56	
31	2.54	3.56	4.06	9	9.2	5.15	5.45	2.79	3.55	2	2.1	4.8	0.2	0.4	2.23	2.49	11.56	
37	2.54	3.56	4.06	9	9.2	5.15	5.45	2.79	3.55	2	2.1	4.8	0.2	0.4	2.23	2.49	11.56	

**NOTES:**

1. All dimensions are in millimetres.
2. For ØA refer to Para. 4.5.3.3 of this specification.
3. Øg: 2-56-UNC-2B.
4. Maximum torque 0.44 Nm.

**FIGURE 2.2C - CONNECTORS TYPE - FR136  
PLUG MALE CONTACTS**

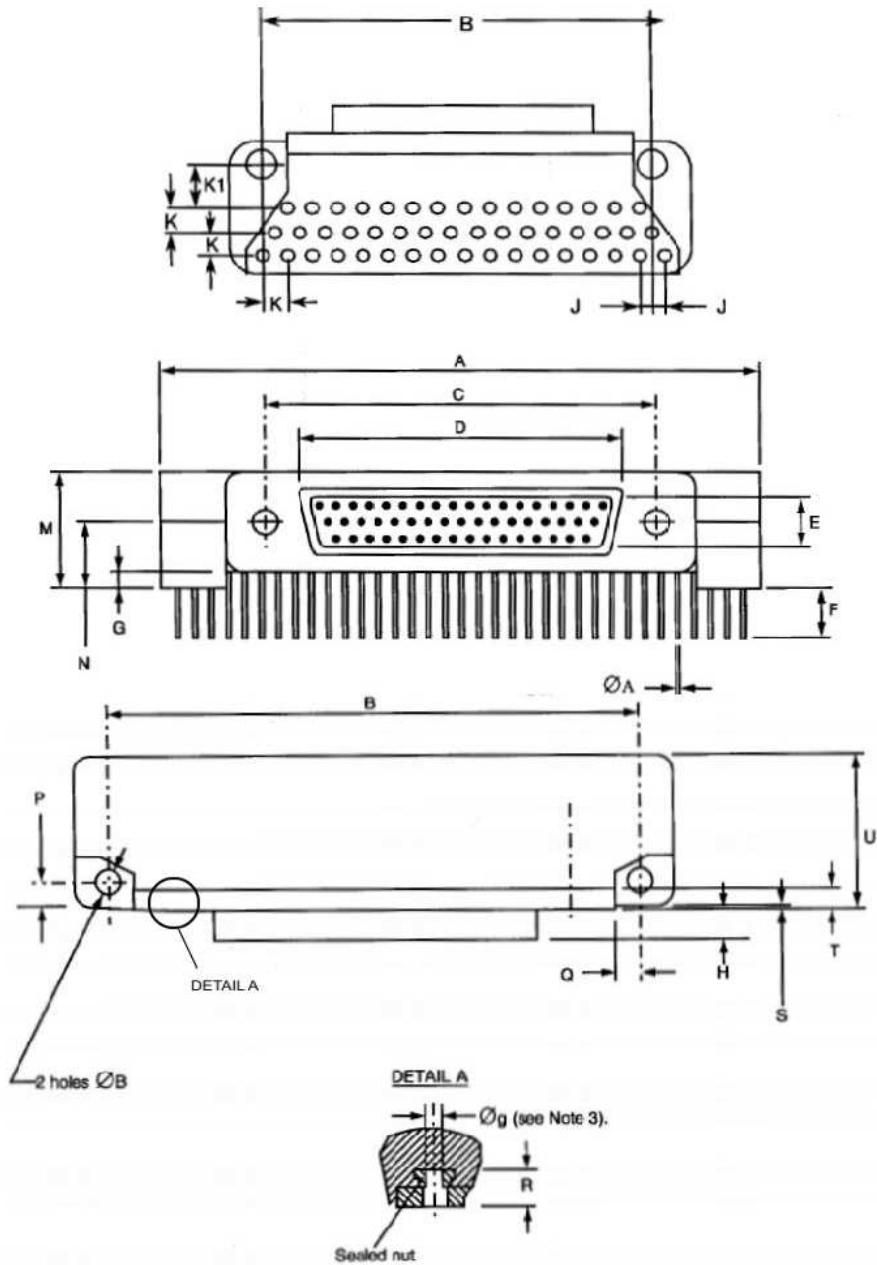

Shell Size	A		B		ØB (4)		C		D	E	F		G		H	J
	Max.	Min.	Max.	Min.	Max.	Min.	Max.	Max.	Max.	Min.	Max.	Min.	Max.	Max.	Typ.	
51	47.63	40.46	40.82	2.31	2.59	30.73	30.99	24.97	5.78	4.15	4.85	1.3	1.7	4.72	1.27	

Shell Size	K	K1		M		N		P		Q		R	S		T	U	
	Max.	Min.	Max.	Min.	Max.	Min.	Max.	Min.	Max.	Min.	Max.	Min.	Min.	Max.	Min.	Max.	Max.
51	2.54	3.56	4.06	10.1	10.4	5.81	6.11	2.79	3.55	2.05	2.15	4.8	0.2	0.4	2.23	2.49	14.35

**NOTES:**

1. All dimensions are in millimetres.
2. For  $\varnothing A$  refer to Para. 4.5.3.3 of this specification.
3.  $\varnothing g$ : 2-56-UNC-2B.
4. Maximum torque 0.44 Nm.

**FIGURE 2.2D - CONNECTORS TYPE - FR136  
RECEPTACLE FEMALE CONTACTS**

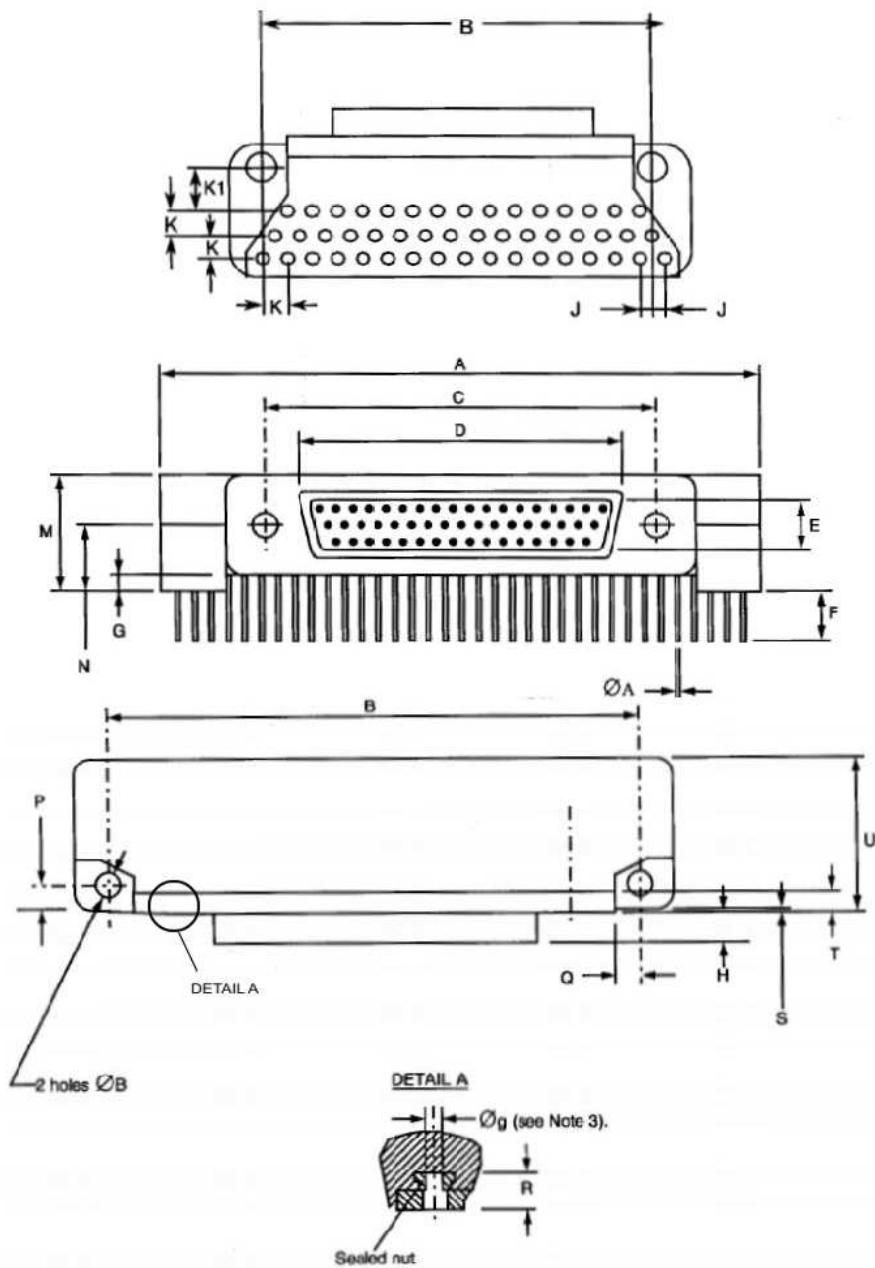

Shell Size	A		B		$\varnothing B$ (4)		C		D	E	E		G		H	J
	Max.	Min.	Max.	Min.	Max.	Min.	Max.	Max.	Max.	Min.	Max.	Min.	Max.	Max.	Typ.	
51	47.63	40.46	40.82	2.31	2.59	30.73	30.99	26.67	7.47	4.15	4.85	1.3	1.7	5.05	1.27	

Shell Size	K	K1		M		N		P		Q		R	S		T		U
	Max.	Min.	Max.	Min.	Max.	Min.	Max.	Min.	Max.	Min.	Max.	Min.	Min.	Max.	Min.	Max.	Max.
51	2.54	3.56	4.06	10.1	10.4	5.81	6.11	2.79	3.55	2.05	2.15	4.8	0.2	0.4	2.23	2.49	14.35

**NOTES:**

1. All dimensions are in millimetres.
2. For  $\varnothing A$  refer to Para. 4.5.3.3 of this specification.
3.  $\varnothing g$ : 2-56-UNC-2B.
4. Maximum torque 0.44 Nm.

**FIGURE 2.2E - CONNECTORS TYPE - FR136A  
PLUG MALE CONTACTS**

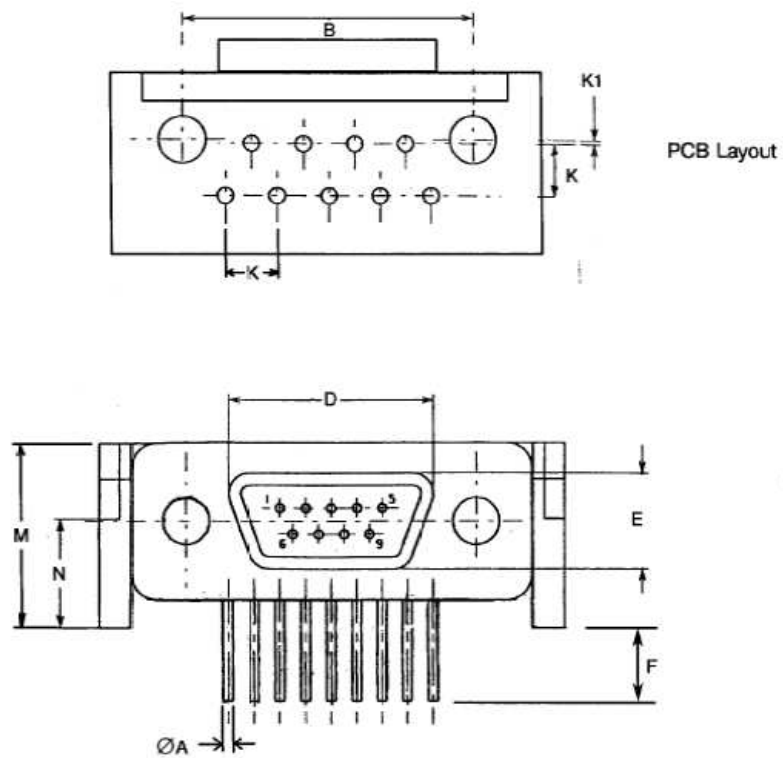



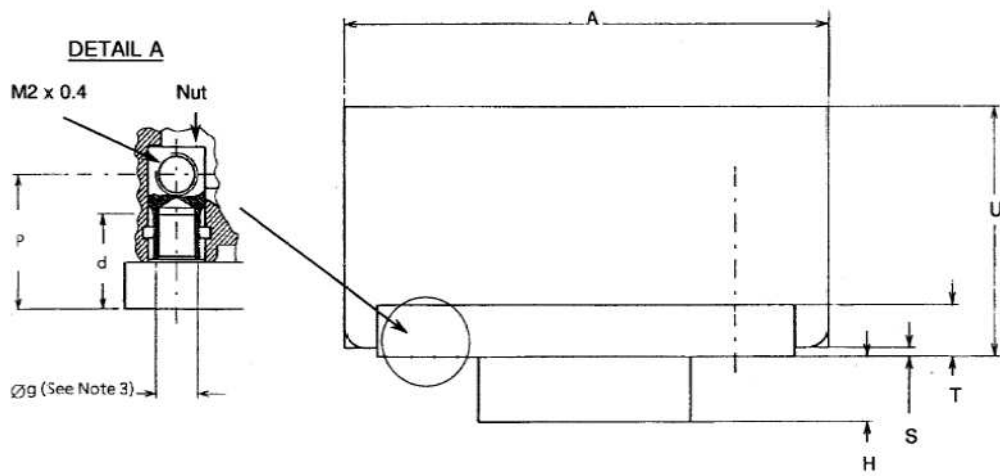

Shell Size	A	B		d	D	E	E		H	K	K1
	Max.	Min.	Max.	Min.	Max.	Max.	Min.	Max.	Max.	Max.	Typ.
9	23.12	14.22	14.48	4.8	8.46	4.69	3.3	3.7	4.72	2.54	0.2

Shell Size	M		N		P		S		T		U
	Min.	Max.	Min.	Max.	Min.	Max.	Min.	Max.	Min.	Max.	Max.
9	9	9.2	5.15	5.45	6.48	7.24	0.2	0.4	2.23	2.49	11.5

**NOTES:**

1. All dimensions are in millimetres.
2. For ØA refer to Para. 4.5.3.3 of this specification.
3. Øg: 2-56-UNC-2B.

**FIGURE 2.2F - CONNECTORS TYPE - FR136A  
RECEPTACLE FEMALE CONTACTS**

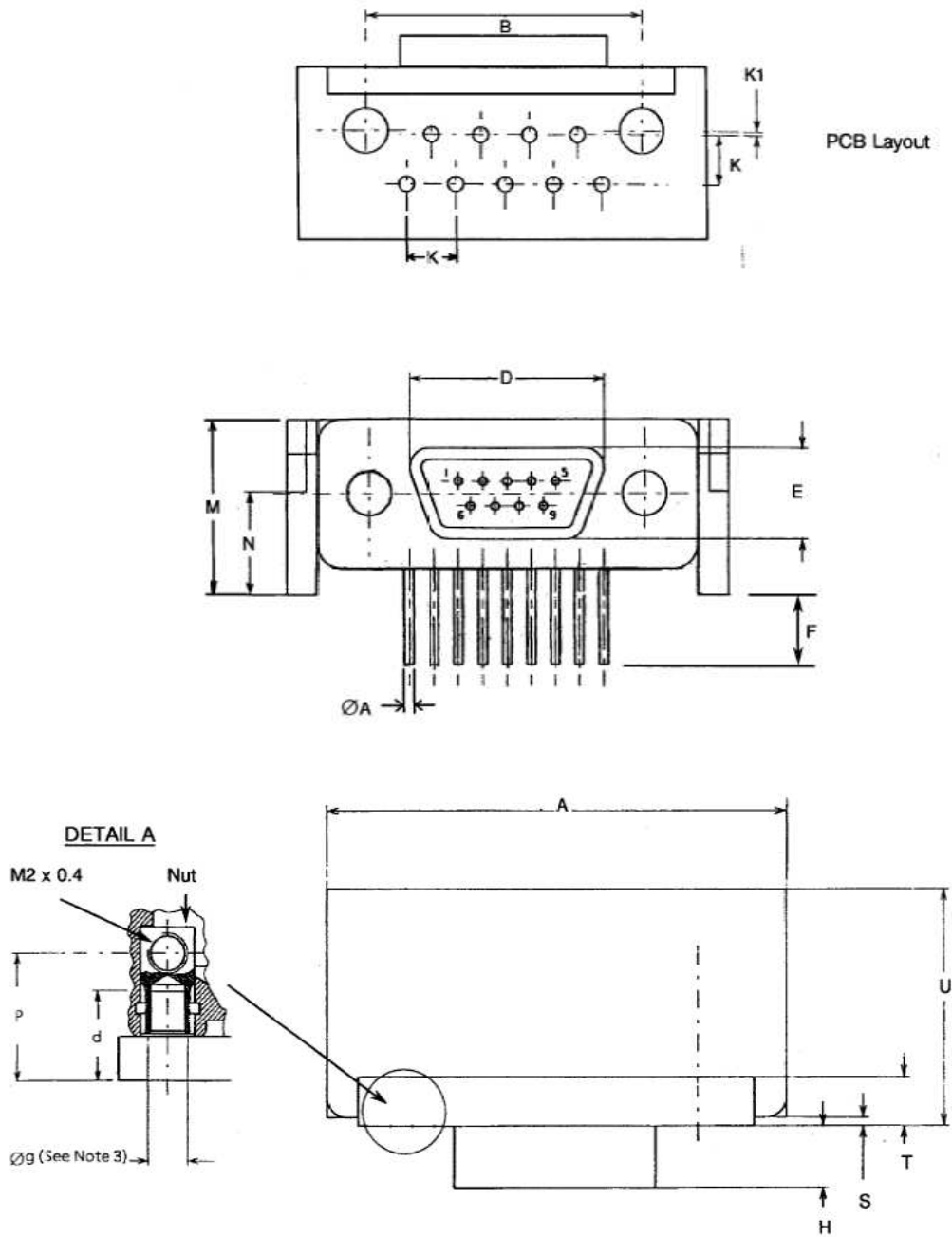

Shell Size	A	B		d	D	E		H	K	K1
	Max.	Min.	Max.	Min.	Max.	Min.	Max.	Max.	Max.	Typ.
9	23.12	14.22	14.48	4.8	10.16	3.3	3.7	5.05	2.54	0.2

Shell Size	M		N		P		S		T		U
	Min.	Max.	Min.	Max.	Min.	Max.	Min.	Max.	Min.	Max.	Max.
9	9	9.2	5.15	5.45	6.48	7.24	0.2	0.4	2.23	2.49	11.5

**NOTES:**

1. All dimensions are in millimetres.
2. For  $\varnothing A$  refer to Para. 4.5.3.3 of this specification.
3.  $\varnothing g$ : 2-56-UNC-2B.

**FIGURE 2.2G - CONNECTORS TYPE - FR139  
PLUG MALE CONTACTS**

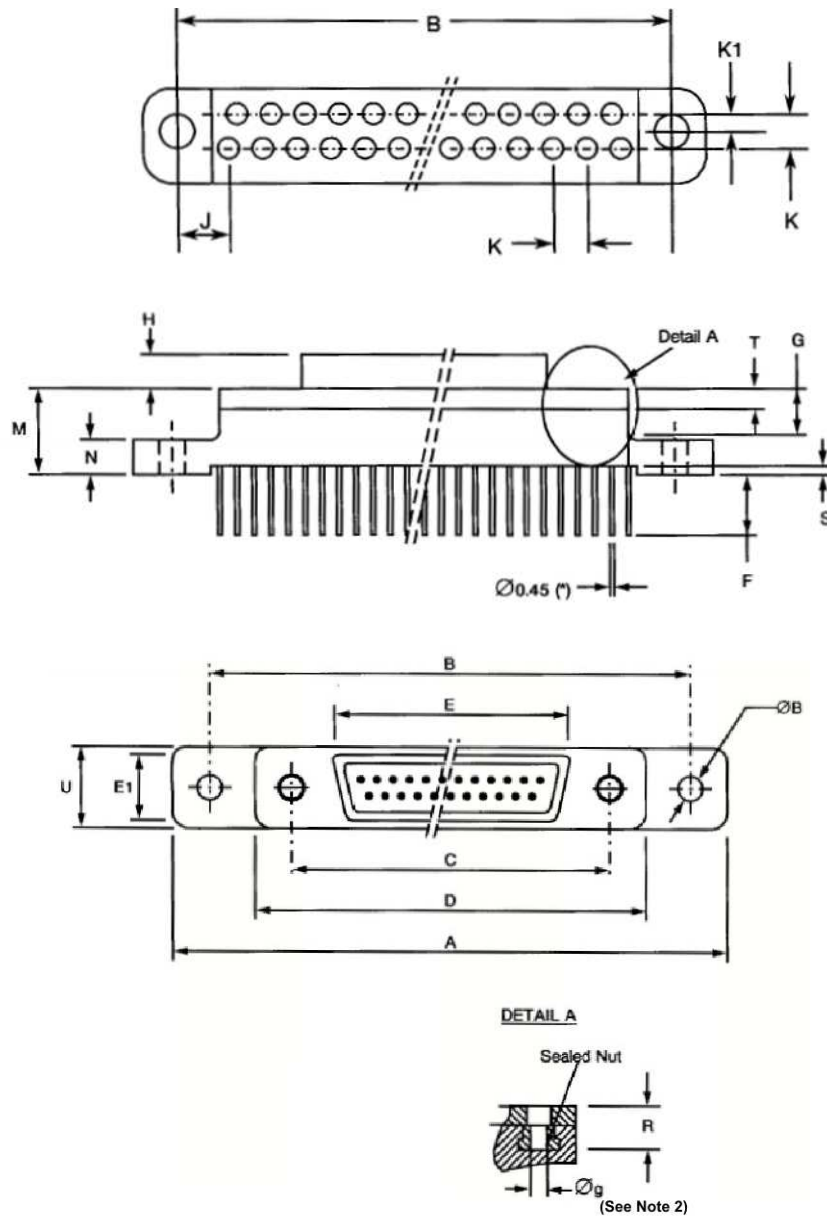

Shell Size	A		B		$\varnothing B$ (3)		C		D	E	E1	E		G	H	J
	Max.	Min.	Max.	Min.	Max.	Min.	Max.	Max.	Max.	Max.	Min.	Max.	Min.	Max.	Typ.	
9	35.31	29.03	29.39	2.31	2.59	14.22	14.48	19.94	8.46	4.69	4.15	4.85	4.6	4.72	9.53	
15	35.31	29.03	29.39	2.31	2.59	18.03	18.29	23.75	12.27	4.69	4.15	4.85	4.6	4.72	5.72	
21	42.93	36.65	37.01	2.31	2.59	21.84	22.1	27.56	16.08	4.69	4.15	4.85	4.6	4.72	5.72	

Shell Size	A	B		ØB (3)		C		D	E	E1	E		G	H	J
	Max.	Min.	Max.	Min.	Max.	Min.	Max.	Max.	Max.	Max.	Min.	Max.	Min.	Max.	Typ.
25	44.2	37.92	38.28	2.31	2.59	24.38	24.64	30.1	18.62	4.69	4.15	4.85	4.6	4.72	3.81
31	51.82	45.54	45.9	2.31	2.59	28.19	28.45	33.91	22.43	4.69	4.15	4.85	4.6	4.72	3.81
37	59.44	53.16	53.52	2.31	2.59	32	32.26	37.72	26.64	4.69	4.15	4.85	4.6	4.72	3.81

Shell Size	K	K1	M		N		R	S		T		U
	Typ.	Typ.	Min.	Max.	Min.	Max.	Min.	Min.	Max.	Min.	Max.	Max.
9	2.54	1.27	8.62	9.02	4	4.2	4.8	0.9	1.1	2.23	2.49	7.82
15	2.54	1.27	8.62	9.02	4	4.2	4.8	0.9	1.1	2.23	2.49	7.82
21	2.54	1.27	8.62	9.02	4	4.2	4.8	0.9	1.1	2.23	2.49	7.82
25	2.54	1.27	8.62	9.02	4	4.2	4.8	0.9	1.1	2.23	2.49	7.82
31	2.54	1.27	8.62	9.02	4	4.2	4.8	0.9	1.1	2.23	2.49	7.82
37	2.54	1.27	8.62	9.02	4	4.2	4.8	0.9	1.1	2.23	2.49	7.82

**NOTES:**

1. All dimensions are in millimetres.
2. Øg: 2-56-UNC-2B.
3. Maximum torque 0.44 Nm.

**FIGURE 2.2H - CONNECTORS TYPE - FR139  
RECEPTACLE FEMALE CONTACTS**

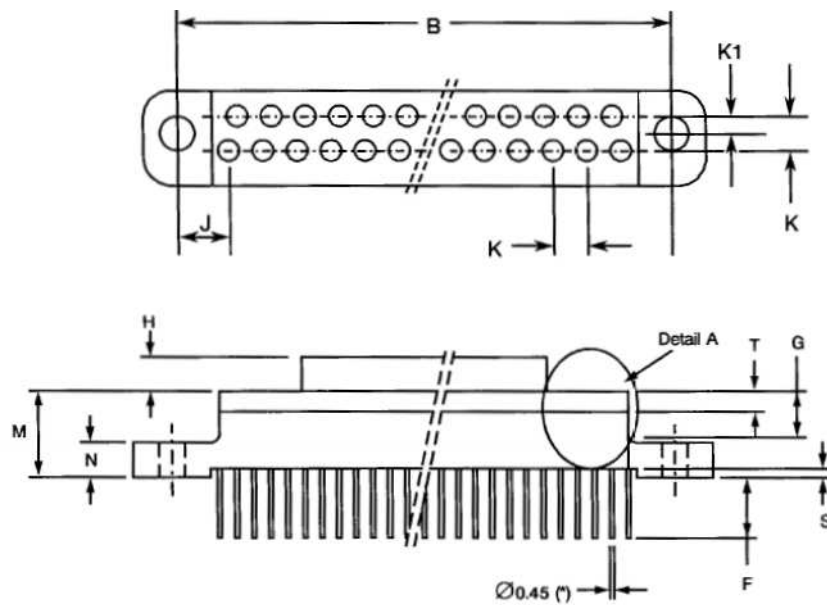

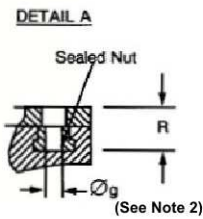
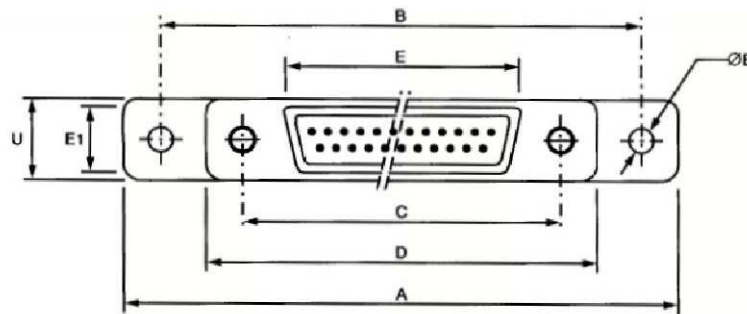

Shell Size	A		B		ØB (3)		C		D	E	E1	E		G	H	J
	Max.	Min.	Max.	Min.	Max.	Min.	Max.	Max.	Max.	Max.	Min.	Max.	Min.	Max.	Typ.	
9	35.31	29.03	29.39	2.31	2.59	14.22	14.48	19.94	10.16	6.38	4.15	4.85	4.6	5.05	9.53	
15	35.31	29.03	29.39	2.31	2.59	18.03	18.29	23.75	13.97	6.38	4.15	4.85	4.6	5.05	5.72	
21	42.93	36.65	37.01	2.31	2.59	21.84	22.1	27.56	17.78	6.38	4.15	4.85	4.6	5.05	5.72	
25	44.2	37.92	38.28	2.31	2.59	24.38	24.64	30.1	20.32	6.38	4.15	4.85	4.6	5.05	3.81	
31	51.82	45.54	45.9	2.31	2.59	28.19	28.45	33.91	24.13	6.38	4.15	4.85	4.6	5.05	3.81	
37	59.44	53.16	53.52	2.31	2.59	32	32.26	37.72	27.94	6.38	4.15	4.85	4.6	5.05	3.81	

Shell Size	K	K1	M		N		R	S		T		U
	Typ.	Typ.	Min.	Max.	Min.	Max.	Min.	Min.	Max.	Min.	Max.	Max.
9	2.54	1.27	8.62	9.02	4	4.2	4.8	0.9	1.1	2.23	2.49	7.82
15	2.54	1.27	8.62	9.02	4	4.2	4.8	0.9	1.1	2.23	2.49	7.82
21	2.54	1.27	8.62	9.02	4	4.2	4.8	0.9	1.1	2.23	2.49	7.82
25	2.54	1.27	8.62	9.02	4	4.2	4.8	0.9	1.1	2.23	2.49	7.82
31	2.54	1.27	8.62	9.02	4	4.2	4.8	0.9	1.1	2.23	2.49	7.82
37	2.54	1.27	8.62	9.02	4	4.2	4.8	0.9	1.1	2.23	2.49	7.82

**NOTES:**

1. All dimensions are in millimetres.
2. Øg: 2-56-UNC-2B.
3. Maximum torque 0.44 Nm.

**FIGURE 2.2I - CONNECTORS TYPE - FR139  
PLUG MALE CONTACTS**

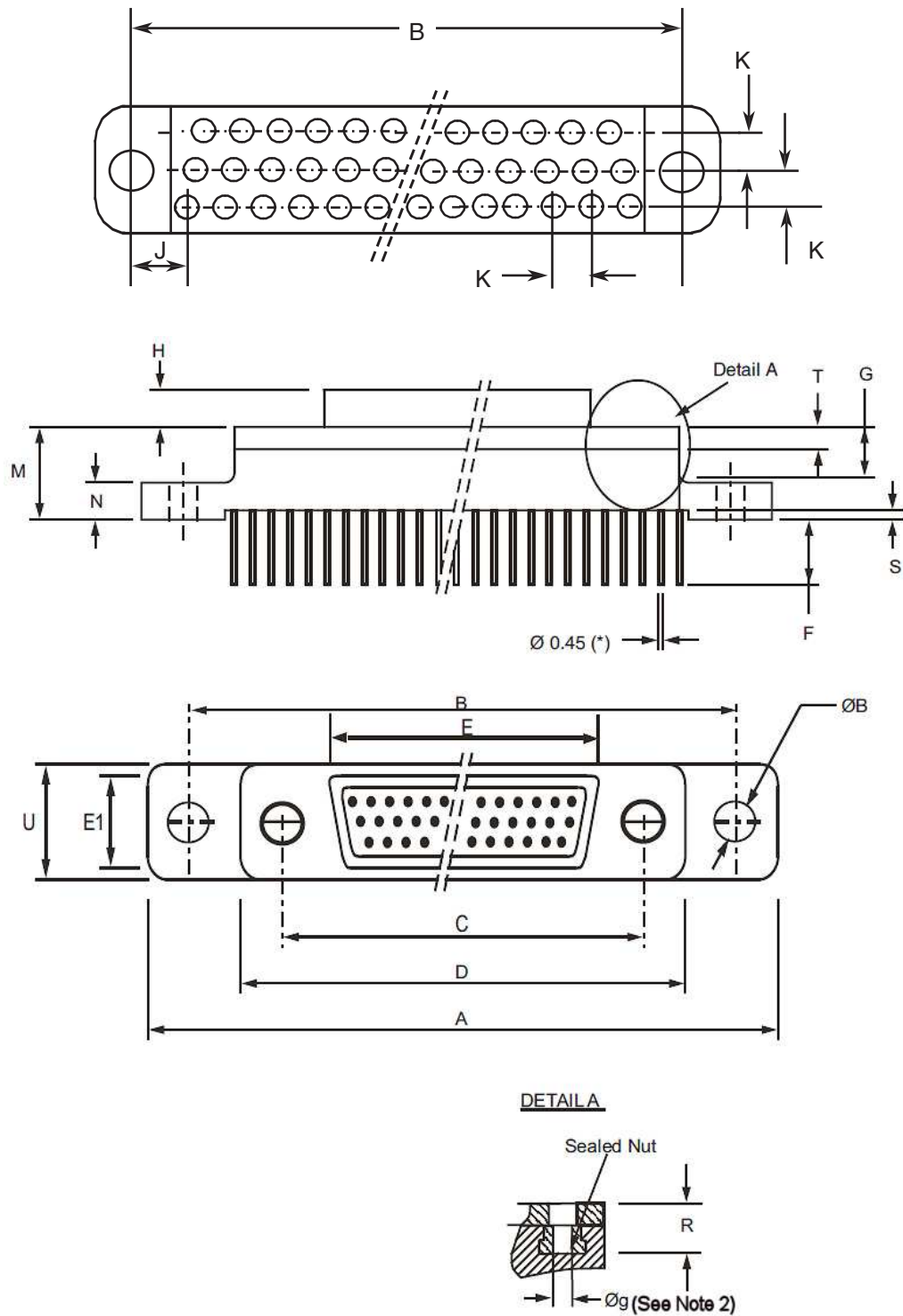

Shell Size	A		B		ØB (3)		C		D	E	E1	E		G	H	J
	Max.	Min.	Max.	Min.	Max.	Min.	Max.	Max.	Max.	Max.	Min.	Max.	Min.	Max.	Typ.	
51	59.44	53.16	53.52	2.31	2.59	30.73	30.99	36.5	24.97	5.78	4.15	4.85	4	4.72	3.81	

Shell Size	K	M		N		R	S		T		U
	Typ.	Min.	Max.	Min.	Max.	Min.	Min.	Max.	Min.	Max.	Max.
51	2.54	8.62	9.02	4	4.2	4.8	0.9	1.1	2.23	2.49	9

**NOTES:**

1. All dimensions are in millimetres.
2. Øg: 2-56-UNC-2B.
3. Maximum torque 0.44 Nm.

**FIGURE 2.2J - CONNECTORS TYPE - FR139  
RECEPTACLE FEMALE CONTACTS**

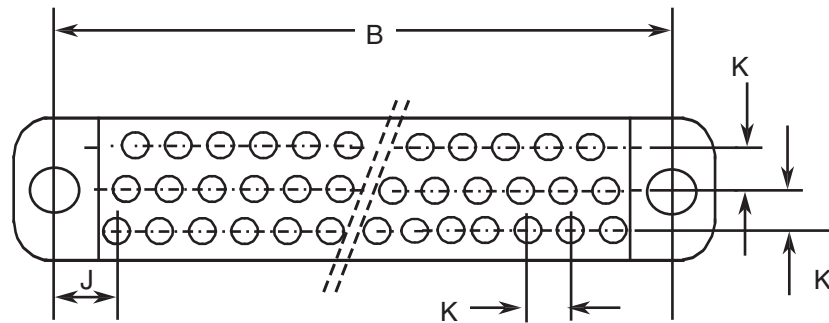

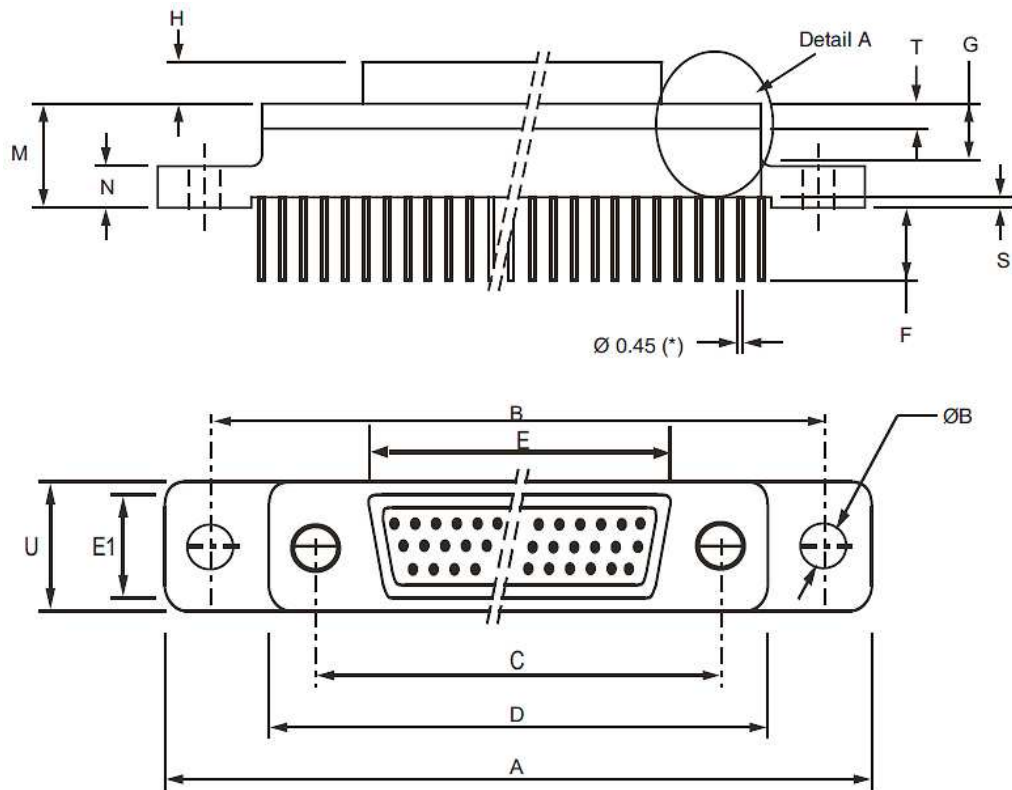

**DETAIL A**

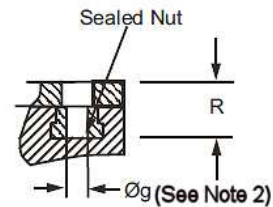

Shell Size	A		B		ØB (3)		C		D	E	E1	E		G	H	J
	Max.	Min.	Max.	Min.	Max.	Min.	Max.	Max.	Max.	Max.	Min.	Max.	Min.	Max.	Typ.	
51	59.44	53.16	53.52	2.31	2.59	30.73	30.99	36.5	26.67	7.47	4.15	4.85	4	5.05	3.81	

Shell Size	K	M		N		R	S		T		U
	Typ.	Min.	Max.	Min.	Max.	Min.	Min.	Max.	Min.	Max.	Max.
51	2.54	8.62	9.02	4	4.2	4.8	0.9	1.1	2.23	2.49	9

**NOTES:**

1. All dimensions are in millimetres.
2. Øg: 2-56-UNC-2B.
3. Maximum torque 0.44 Nm.



**FIGURE 2.3 - CONTACT POSITIONS**

Figure 2.3.1 - Mounting Condition

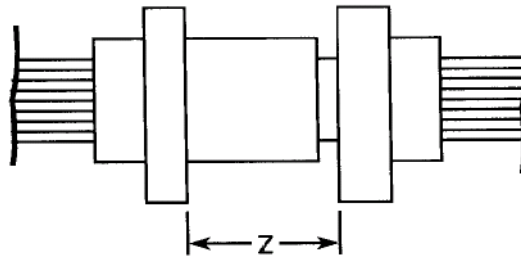

Figure 2.3.2 - Plug Male Contact

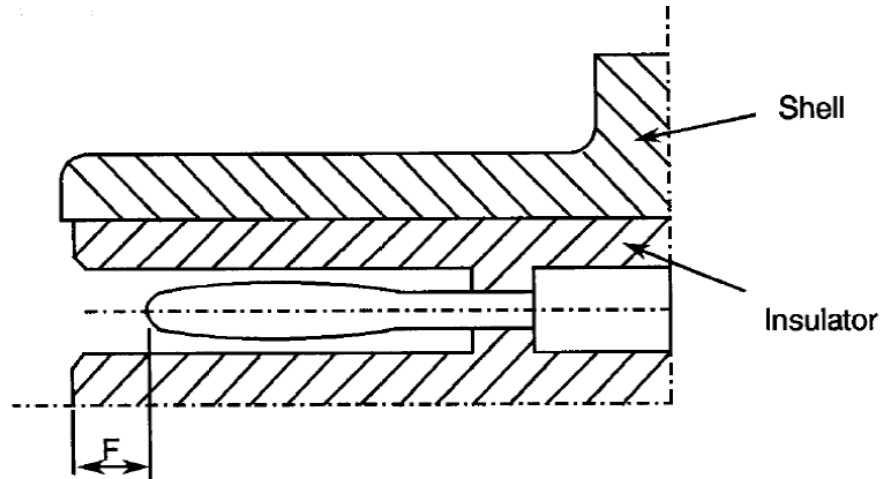
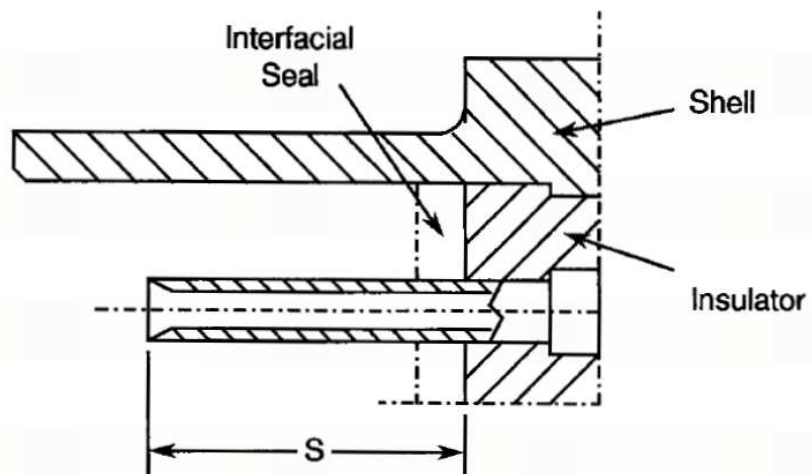

Figure 2.3.3 - Receptacle Female Contact



F		S		Z
Min	Max	Min	Max	Max
0.25	0.91	3.3	3.66	5.49

**NOTES:**

- All dimensions are in millimetres.

**FIGURE 2.4 - UNINSULATED SOLID WIRES**

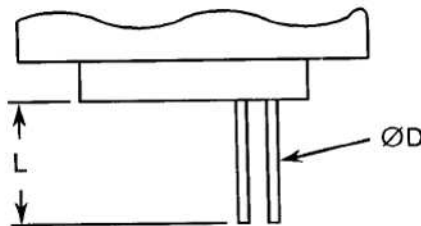

Wire Size (AWG)	25
Max Diameter D (mm)	0.46
Min Diameter D (mm)	0.45
Min Gold Plating Thickness (µm)	0.5
Max Weight (g/m)	1.6
Min. Length L	See Para. 4.5.3.3

**FIGURE 2.5 - INSULATED WIRES**

		ESCC 3901/002		ESCC 3901/013	
		Wire Size (AWG)			
		26	28	26	28
Conductor Characteristics	Maximum Diameter (mm)	0.53	0.43	0.5	0.42
	Nominal Cross-section (mm <sup>2</sup> )	0.15	0.1	0.14	0.1
Wire Characteristics	Maximum Diameter (mm)	0.78	0.68	0.89	0.82
	Maximum Weight (g/m)	1.93	1.23	2.3	1.8
	Colour	Black	Brown	Natural	Natural
	Minimum Length	See Para. 4.5.3.3			

FIGURE 2.6 - FLOATING MOUNT

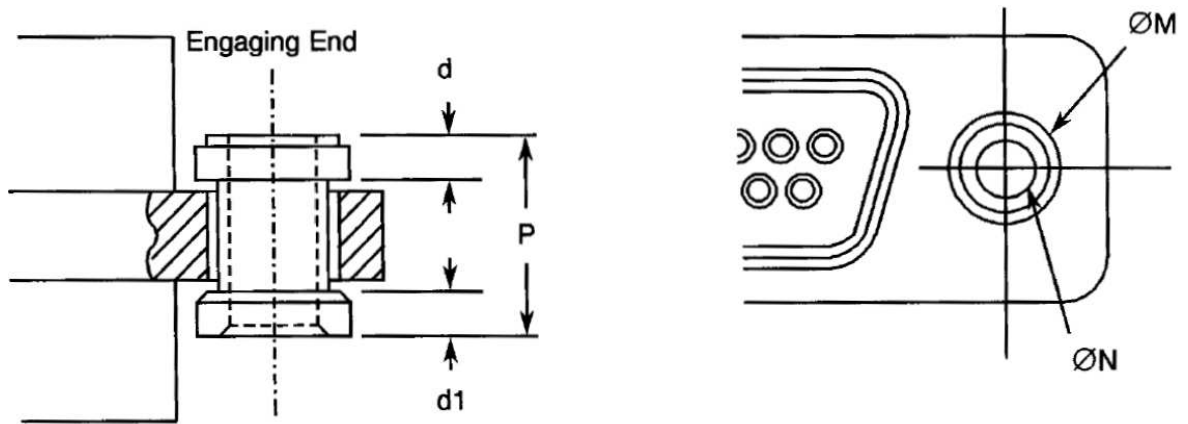

P Max	d	d1	ØM Max	ØN Min
4.7	1.0	0.8	4	2.26

**NOTES:**

1. All dimensions are in millimetres.
2. Total Lateral Float 0.4 (typical).
3. Total Axial Float 0.4 (typical).

FIGURE 2.7 - CAPTIVE NUT

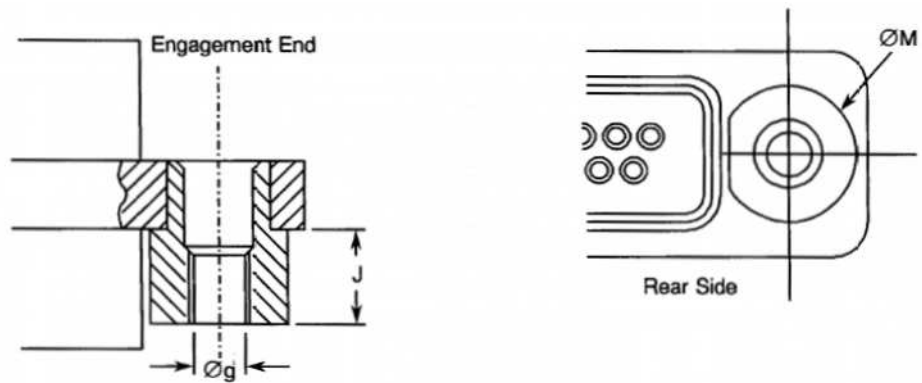

Øg	J Max	ØM Max
Note 2	2.6	5.1

**NOTES:**

1. All dimensions are in millimetres.
2. Øg: 2-56 UNC 2B, Maximum Torque 0.44Nm.

**FIGURE 3 - CONTACT ARRANGEMENTS**  
**FRONT VIEW OF MALE INSERT - USE MIRROR VIEW FOR FEMALE INSERT**

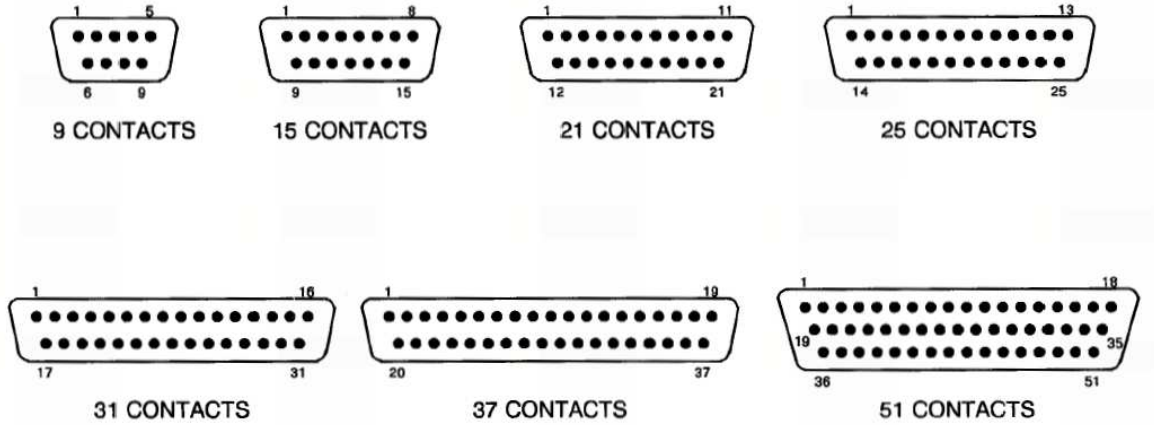

**NOTES:**

1. Only the outside contact cavities on each row are identified in the drawing, the remainder follow sequentially. Contact numbers are shown outside the insert for readability.

**Contact Centres**

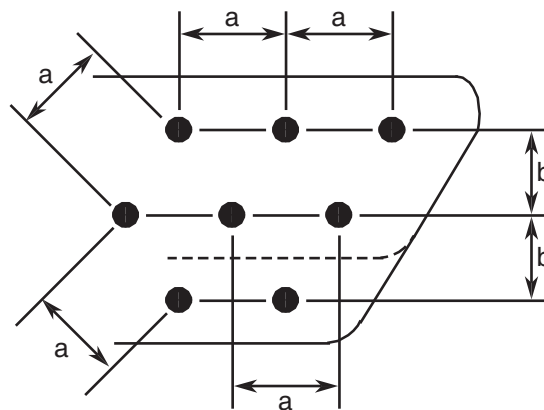

**NOTES:**

1. a = Distance between contact centres: 1.27mm (typical).
2. b = Distance between rows: 1.09mm (typical).

**4. REQUIREMENTS**

**4.1 GENERAL**

The complete requirements for procurement of the connectors specified herein are stated in this specification and ESCC Generic Specification No. 3401. Deviations from the Generic Specification, applicable to this specification only, are listed in Para. 4.2.

Deviations from the applicable Generic Specification and this Detail Specification, formally agreed with specific Manufacturers on the basis that the alternative requirements are equivalent to the ESCC requirements and do not affect the components' reliability, are listed in the appendices attached to this

specification.

4.2 DEVIATIONS FROM GENERIC SPECIFICATION

4.2.1 Deviations from Special In-Process Controls

Para. 9.15, Joint strength: the contacts shall be crimped to insulated stranded wire AWG26 and AWG28, and to uninsulated solid wire AWG25. The value of failure shall be recorded together with the information as to whether the failure was 'pull-out', 'break in crimp' or 'break in wire'. the minimum tensile strength shall be as follows:

Wire	Male and Female Contacts		
	AWG26	AWG28	AWG25 - Solid Uninsulated
Tensile Strength (N)	22	13	22

4.2.2 Deviations from Final Production Tests (Chart II)

- (a) Para. 9.4, Contact Capability: this test shall be performed on the male contacts. For details see Para. 4.3.3 of this specification.
- (b) Para. 9.5, Magnetism Level: Not applicable.

4.2.3 Deviations from Burn-in and Electrical Measurements (Chart III)

None (Chart III is not applicable).

4.2.4 Deviations from Qualification Tests (Chart IV)

- (a) Para. 9.15, Joint Strength: Not applicable.
- (b) Para. 9.17, Contact Retention (in insert): Not applicable with male contact.
- (c) Para. 9.27, Maintenance Ageing: Not applicable.
- (d) Para. 9.29, Oversize Pin Exclusion: Not applicable.
- (e) Para. 9.30, Probe Damage: Not applicable.
- (f) Para. 9.31, Solderability: Not applicable.

4.2.5 Deviations from Lot Acceptance Tests (Chart V)

- (a) Para. 9.15, Joint Strength: Not applicable.
- (b) Para. 9.17, Contact Retention (in insert): Not applicable with male contact.
- (c) Para. 9.27, Maintenance Ageing: Not applicable.
- (d) Para. 9.29, Oversize Pin Exclusion: Not applicable.
- (e) Para. 9.30, Probe Damage: Not applicable.

4.3 MECHANICAL REQUIREMENTS

4.3.1 Dimension Check

The dimensions of the connectors specified herein shall be verified in accordance with the requirements set out in Para. 9.6 of ESCC Generic Specification No. 3401 and shall conform to those shown in Figure 2 of this specification. Only the underlined dimensions shall be checked during procurement.

4.3.2 Weight

The maximum weight of the connectors specified herein shall be calculated on the basis of, and be in accordance with the values given in Table 1(a) and in Figures 2.4 and 2.5 of this specification.

4.3.3 Contact Capability

For the purpose of this test, the pick-up and drop weights shall be as follows.

Measurements	Pick-Up Weight	Drop Weight
Weight (g)	14	170
Inner Gauge Diameter (mm) (1)	0.582 - 0.587	0.559 - 0.564
Insertion Depth (mm)	1.5	1.5

**NOTES:**

1. See Figure 4 for ØA.

4.3.4 Contact Retention (in Insert)

Contact retention within the insert shall be 22.25 Newtons. There shall be no displacement of the contact. Not applicable to male contacts.

4.3.5 Mating and Unmating Forces

The forces applied for the mating and unmating of the connectors shall conform to the values specified in Table 1(a).

4.3.6 Insert Retention (in Shell)

Connector inserts shall withstand a pressure of 34.4N/cm<sup>2</sup> applied from the mating side to the rear side.

4.3.7 Jackscrew Retention

Not applicable.

4.3.8 Contact Insertion and Withdrawal Forces

Not applicable.

4.3.9 Engagement and Separation Forces (Male Contacts)

The contact engagement and separation forces of the male contacts shall be tested to a depth of 1.5mm with the applicable test gauge fixtures specified in Figure 4 of this specification, and shall not exceed the values of the table hereunder.

Measurements	Inner Diameter (mm)		Separation Force Min. (N)	Engagement Force Max. (N)
	Min.	Max.		
Max. Gauge Fixture	0.559	0.564	-	1.667
Min. Gauge Fixture	0.582	0.587	0.137	-

4.3.10 Oversize Pin Exclusion

Not applicable.

4.3.11 Probe Damage  
Not applicable.

4.3.12 Solderability  
Not applicable.

#### 4.4 MATERIALS AND FINISHES

The materials and finishes shall be as specified herein. Where a definite material is not specified, a material which will enable the components specified herein to meet the performance requirements of this specification shall be used. Acceptance or approval of any constituent material does not guarantee acceptance of the finished product.

4.4.1 Shells  
Shells shall be made of aluminium alloy. The plating shall be 25.4µm minimum of electroless nickel (Variant 01) or with a minimum thickness of 2.54µm of gold over a layer of electroless nickel underlay (Variant 02).

4.4.2 Inserts  
Inserts shall be made of glass fibre-filled diallylphthalate resin or suitable thermoplastic material.

#### 4.4.3 Contacts

##### 4.4.3.1 *Female Contacts*

The contact body shall be made of copper alloy with an underplate of 1µm minimum of copper to MIL-C-14550, gold plated with 1.27µm minimum of gold, Type 2, Grade C of MIL-DTL-45204. Measurement of thickness shall be performed at a distance of 1.5mm from the engagement end.

##### 4.4.3.2 *Male Contacts*

The contact body and the bundle shall be made of copper alloy with an underplate of 1µm minimum of copper to MIL-C-14550, gold plated with 1.27µm minimum of gold, Type 2, Grade C of MIL-DTL-45204. Measurement of thickness shall be performed at a distance of 1.5mm from the engagement end.

#### 4.4.4 Interfacial Seals

Interfacial seals shall be made of silicon base rubber.

#### 4.4.5 Insulated Wires

Wire materials and finishes shall be in accordance with the requirements specified in Para. 4.4 of ESCC Detail Specifications No. 3901/002 and 3901/013.

#### 4.4.6 Uninsulated Solid Wire

Uninsulated solid wires shall be made of copper alloy in accordance with Type S as specified in QQ-W-343. They shall be gold-plated in accordance with Class ØØ, Grade C or D, as specified in MIL-DTL-45204.

#### 4.4.7 Rear Potting

Rear potting shall be made of epoxy resin. For connectors Type FR136, Type FR136A and Type FR139, the rear container shall be made from glass-fibre filled diallylphthalate resin.

## 4.5 MARKING

### 4.5.1 General

The marking of all components delivered to this specification shall be in accordance with the requirements of ESCC Basic Specification No. 21700 and the following paragraphs.

Each component shall be marked in respect of:

- (a) The ESCC Component Number.
- (b) Characteristics.
- (c) Traceability Information.

### 4.5.2 The ESCC Component Number

Each component shall bear the ESCC Component Number which shall be constituted and marked as follows:

340102901B

- Detail Specification Number: 3401029
- Type Variant (See Table 1(a)): 01
- Testing Level: B

#### **N.B.**

Marking of the Type Variant is mandatory. No further reference to type variant is made in this specification.

### 4.5.3 Characteristics

The characteristics to be marked in the following order of precedence are:

- (a) Shell Size.
- (b) Contact Type.
- (c) Termination Type.
- (d) Mounting.

The information shall be constituted and marked as follows (example): 51PFR112F

- Shell size: 51
- Contact type: P
- Termination Type: FR112
- Mounting: F

#### 4.5.3.1 *Shell Size*

Shell size shall be designated by the number of contacts.

Specified numbers are: 9, 15, 21, 25, 31, 37 and 51.



4.5.3.2 *Contact Type*

Contact types shall be indicated by the following code letters.

Code Letter	Contact Type
P	Male
S	Female

4.5.3.3 *Termination Type*

Codes defining the termination type and details according to Figures 2.1, 2.2, 2.4 and 2.5 as follows:-.

Code	Type	Min. Length (mm)
FR112	AWG26 Wire 390101302B	508
FR112A	AWG26 Wire 390100256B	508
FR113	AWG26 Wire 390101302B	914
FR113A	AWG26 Wire 390100256B	914
FR123	AWG26 Wire 390101302B	4000
FR123A	AWG26 Wire 390100256B	4000
FR114	AWG28 Wire 390101301B	508
FR114A	AWG28 Wire 390100261B	508
FR115	AWG28 Wire 390101301B	914
FR115A	AWG28 Wire 390100261B	914
FR116	Uninsulated Wire	25.4
FR136 FR136A	90° Mounting on PCB	-
FR139	Straight Mounting on PCB	-

4.5.3.4 *Mounting*

The letter E indicates a captive nut.

The letter F shall indicate a floating mount.

If the shell has fixed mounting holes, these letters shall be omitted.

4.5.4 Traceability Information

Traceability information shall be marked in accordance with the requirements of ESCC Basic Specification No. 21700.

4.6 ELECTRICAL MEASUREMENTS

4.6.1 Electrical Measurements at Room Temperature

The parameters to be measured in respect of electrical characteristics are scheduled in Table 2. Unless otherwise specified, the measurements shall be performed at  $T_{amb} = +22 \pm 3^{\circ}C$ .

4.6.2 Electrical Measurements at High and Low Temperatures

Not applicable.

4.6.3 Circuits for Electrical Measurements

Not applicable.

4.7 BURN-IN AND ELECTRICAL MEASUREMENTS (TABLES 4 AND 5)

Not applicable.

**Table 2 - ELECTRICAL MEASUREMENTS AT ROOM TEMPERATURE**

No.	Characteristic	Symbol	ESCC 3401 Test Method	Test Condition	Limits		Unit
					Min	Max	
1	Insulation Resistance	$R_i$	Para. 9.1.1.1	Para. 9.1.1.1	5000	-	$M\Omega$
2	Voltage Proof Leakage Current	$I_L$	Para. 9.1.1.2	600Vrms	-	2	mA
3	Mated Shell Conductivity (Voltage Drop) Note 1	$V_D$	Para. 9.1.1.4	Para. 9.1.1.4	Not applicable		mV
4	Contact Resistance (Low Level Current)	$R_{cl}$ max.	Para. 9.1.1.3	Para. 9.1.1.3	-	6	$m\Omega$
5	Contact Resistance (Rated Current)	$R_{cr}$ max.	Para. 9.1.1.3	Table 1(b)	-	5	$m\Omega$

**NOTES:**

1. Applicable to mated connectors with grounding option.

**TABLES 3, 4 AND 5**

Not applicable.

**FIGURE 4 - GAUGE FIXTURE**

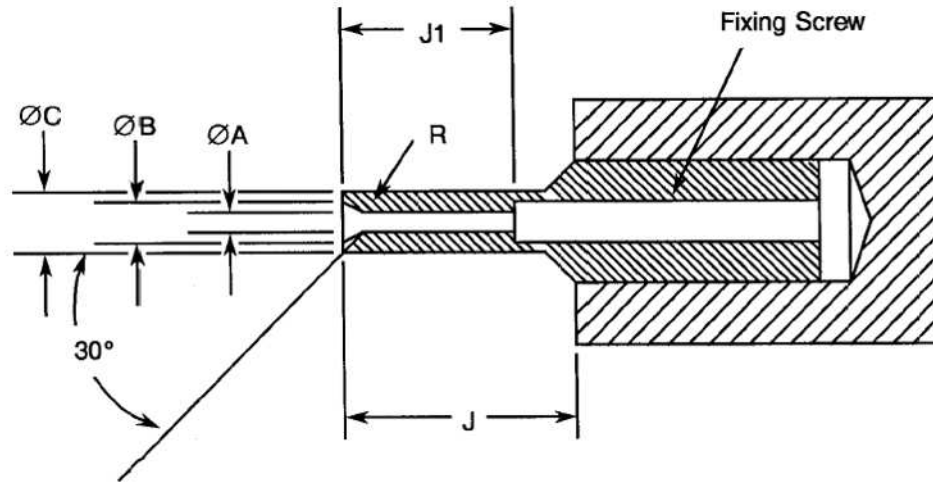

MAXIMUM GAUGE

Weight (g) 170			Remarks
Symbol	Min.	Max.	
ØA	0.559	0.564	Note 2
ØB	0.749	0.775	-
ØC	0.813	0.825	-
J	4	-	-
J1	3.13	3.23	-
R	0.381	0.483	Note 1

MINIMUM GAUGE

Weight (g) 14			Remarks
Symbol	Min.	Max.	
ØA	0.582	0.587	Note 2
ØB	0.749	0.775	-
ØC	0.813	0.825	-
J	4	-	-
J1	3.13	3.23	-
R	0.381	0.483	Note 1

**NOTES:**

1. Radius R, must be tangent to entry chamfer and ØA.
2. ØA and entry chamfer shall have a surface roughness of 3.2µm (roughness grade N8).

4.8 ENVIRONMENTAL AND ENDURANCE TESTS (CHARTS IV AND V OF ESCC GENERIC SPECIFICATION NO. 3401)

4.8.1 Measurements and Inspections on Completion of Environmental Tests

The parameters to be measured and inspections to be performed on completion of environmental testing shall be those specified in Table 6. Unless otherwise specified, these measurements shall be performed at  $T_{amb} = +22 \pm 3^{\circ}C$ .

4.8.2 Measurements and Inspections at Intermediate Points during Endurance Tests

Not applicable.

4.8.3 Measurements and Inspections on Completion of Endurance Tests

The parameters to be measured and inspections to be performed on completion of endurance testing shall be those specified in Table 6. Unless otherwise specified, these measurements shall be performed at  $T_{amb} = +22 \pm 3^{\circ}C$ .

4.8.4 Conditions for Operating Life Test (Part of Endurance Testing)

Not applicable.

4.8.5 Electrical Circuit for Operating Life Test

Not applicable.

4.8.6 Conditions for High Temperature Storage Test (Part of Endurance Testing)

The requirements for the high temperature storage test are specified in Section 9 of ESCC Generic Specification No. 3401. The temperature to be applied shall be the maximum storage temperature specified in Table 1(b) of this specification.

**Table 6 - MEASUREMENTS AND INSPECTIONS ON COMPLETION OF ENVIRONMENTAL AND ENDURANCE TESTING**

No.	ESCC Generic Spec. No. 3401		Measurements and Inspections		Symbol	Limits		Unit
	Environmental and Endurance Tests Note 1	Test Method and Conditions	Identification	Conditions		Min	Max	
01	Seal Test	Para. 9.9	ESCC 3401 Para. 9.9			Not applicable		-
02	Wiring	Para. 9.10	Low Level Contact Resistance	Table 2 Item 4	$R_{cl}$	Table 2, Item 4		-
03	Vibration	Para. 9.11	<b>Initial Measurements</b> Coupling screw(s) Unlocking Torque		$T_{qe}$	Record Values		-
			<b>Final Measurements</b> Full Engagement Coupling screw(s) Unlocking Torque Drift Visual Examination	-	$\Delta T_{qe}/T_{qe}$ -	-25 -	+25 -	%
04	Shock or Bump	Para. 9.12	Full Engagement Visual Examination	-	-	-	-	-
05	Climatic Sequence	Para. 9.13	<b>Dry Heat</b> Insulation Resistance	At High Temperature Table 2, Item 1 (2)	$R_i$	10	-	MΩ
			<b>Low Air Pressure</b> Voltage Proof Leakage Current	Figure 1	$I_L$	ESCC 3401 Para. 9.13.5		mA

No.	ESCC Generic Spec. No. 3401		Measurements and Inspections		Symbol	Limits		Unit
	Environmental and Endurance Tests Note 1	Test Method and Conditions	Identification	Conditions		Min	Max	
			<b>Damp Heat</b> Insulation Resistance	Immediately after test Table 2, Item 1	$R_i$	100	-	$M\Omega$
			<b>Final Measurements</b> External Visual Inspection	After 1-24 hrs Recovery ESCC 3401 Para. 9.7		ESCC 3401 Para. 9.7		
			Insulation Resistance	Table 2, Item 1	$R_i$	Table 2, Item 1		$M\Omega$
			Voltage Proof Leakage Current	Table 2, Item 2	$I_L$	Table 2, Item 2		mA
06	Plating Thickness	Para. 9.14	Thickness	-	-	Para. 4.4.3 of this spec.		
07	Joint Strength (N/A to solder contacts)	Para. 9.15	ESCC 3401 Para. 9.15	-	-	Not applicable		-
08	Rapid Change of Temperature	Para. 9.16	Visual Examination	-	-	-	-	-
			Insulation Resistance	Table 2, Item 1	$R_i$	Table 2, Item 1		$M\Omega$
			Voltage Proof Leakage Current	Table 2, Item 2	$I_L$	Table 2, Item 2		mA
09	Contact Retention (in Insert)	Para. 9.17 & Para. 4.3.4 of this spec.	Contact Displacement	-	-	ESCC 3401 Para. 9.17		
10	Endurance	Para. 9.18	<b>Initial Measurements</b> Mating/Unmating Forces		F	Para. 4.3.5 of this spec.		N
			Low Level Contact Resistance	Table 2, Item 4	$R_{cl}$	Record Values		$m\Omega$
			Mated Shell Conductivity	Table 2, Item 3	$V_D$	Not applicable		mV
			<b>Final Measurements</b> Visual Examination	-	-	-	-	
			Mating/Unmating Forces		F	Para. 4.3.5 of this spec		N
			Low Level Contact Resistance Drift	Table 2, Item 4	$\Delta R_{cl}$	-	3	$m\Omega$
			Rated Current Contact Resistance	Table 2, Item 5	$R_{cr}$	Table 2, Item 5		$m\Omega$
			Mated Shell Conductivity	Table 2 Item 3	$V_D$	Not applicable		mV
			Insulation Resistance	Table 2 Item 1	$R_i$	Table 2, Item 1		$M\Omega$
			Voltage Proof Leakage Current	Table 2 Item 2	$I_L$	Table 2, Item 2		mA
11	Permanence of Marking	Para. 9.19	-	-	-	-		
12	Mating/Unmating Forces	Para. 9.20	Force	-	F	Para. 4.3.5 of this spec		N
13	High Temperature Storage	Para. 9.21	<b>Initial Measurements</b> Low Level Contact Resistance	Table 2, Item 4	$R_{cl}$	Record Values		$m\Omega$
			Mated Shell Conductivity	Table 2, Item 3	$V_D$	Not applicable		mV
			<b>Final Measurements</b> Visual Examination	-	-	-	-	
			Mating/Unmating Forces		F	Para. 4.3.5 of this spec		N
			Low Level Contact Resistance Drift	Table 2, Item 4	$\Delta R_{cl}$	-	3	$m\Omega$

No.	ESCC Generic Spec. No. 3401		Measurements and Inspections		Symbol	Limits		Unit
	Environmental and Endurance Tests Note 1	Test Method and Conditions	Identification	Conditions		Min	Max	
			Rated Current Contact Resistance Mated Shell Conductivity Insulation Resistance Voltage Proof Leakage Current Contact Retention (In insert)	Table 2, Item 5  Table 2 Item 3 Table 2 Item 1 Table 2 Item 2  Para. 4.3.4 of this spec.	$R_{cr}$  $V_D$ $R_i$ $I_L$	Table 2, Item 5  Not applicable Table 2, Item 1 Table 2, Item 2  ESCC 3401 Para. 9.17	mΩ  mV MΩ mA	
14	Corrosion	Para. 9.22	Visual Examination	-	-	-	-	
15	Insert Retention (in Shell)	Para. 9.23 & Para. 4.3.6 of this spec.	Visual Examination	-	-	Para. 4.3.6 of this spec.		
16	Jackscrew Retention	Para. 9.24 & Para. 4.3.7 of this spec	Visual Examination			Not applicable		
17	High Temperature Measurements	Para. 9.25	Insulation Resistance	Table 2 Item 1 (2)	$R_i$	10	-	MΩ
18	Overload Test	Para. 9.26	Internal Temperature Rated Current Contact Resistance Mated Shell Conductivity Insulation Resistance Voltage Proof Leakage Current	-  Table 2, Item 5  Table 2 Item 3 Table 2 Item 1 Table 2 Item 2	$T$  $R_{cr}$  $V_D$ $R_i$ $I_L$	-  Table 2, Item 5  Not applicable Table 2, Item 1 Table 2, Item 2	+100  mΩ  mV MΩ mA	
19	Maintenance Ageing	Para. 9.27	Visual Examination Contact Retention (in Insert)	-  Para. 4.3.4 of this spec.	-	-	-	N
20	Engage/Separation Forces	Para. 9.28 & Para. 4.3.9 of this spec.	Force	-	F	Para. 4.3.9 of this spec.		N
21	Oversize Pin Exclusion	Para. 9.29 & Para. 4.3.10 of this spec.	Not applicable	-	-	-	-	-
22	Probe Damage	Para. 9.30 & Para. 4.3.11 of this spec.	Not applicable	-	-	-	-	-
23	Solderability	Para. 9.31 & Para. 4.3.12 of this spec.	Not applicable	-	-	-	-	-

**NOTES:**

1. The tests in this Table refer to either Chart IV or V and shall be used as applicable.
2.  $T_{amb}=+125^{\circ}C$ .

**APPENDIX 'A' - AGREED DEVIATIONS FOR C & K COMPONENTS (F)**

ITEMS AFFECTED	DESCRIPTION OF DEVIATIONS
Para. 4.2.2, Deviations from Final Production Tests (Chart II)	Para. 9.4, Contact Capability: 100% Contact Capability Test may be omitted provided that a 100% visual inspection of the contacts is performed on each batch submitted to tests defined in the C&K PID requirements.