



**RESISTORS, FIXED, WIREWOUND, POWER-TYPE,
CHASSIS-MOUNTED, 10W, SEMI-PRECISION
BASED ON TYPE RER65
ESCC Detail Specification No. 4003/002**

**ISSUE 1
October 2002**



	ESCC Detail Specification		PAGE ii ISSUE 1
---	---------------------------	--	--------------------

LEGAL DISCLAIMER AND COPYRIGHT

European Space Agency, Copyright © 2002. All rights reserved.

The European Space Agency disclaims any liability or responsibility, to any person or entity, with respect to any loss or damage caused, or alleged to be caused, directly or indirectly by the use and application of this ESCC publication.

This publication, without the prior permission of the European Space Agency and provided that it is not used for a commercial purpose, may be:

- copied in whole in any medium without alteration or modification.
- copied in part, in any medium, provided that the ESCC document identification, comprising the ESCC symbol, document number and document issue, is removed.



european space agency
agence spatiale européenne

Pages 1 to 19

RESISTORS, FIXED, WIREWOUND, POWER-TYPE,

CHASSIS-MOUNTED, 10W, SEMI-PRECISION

BASED ON TYPE RER65

ESA/SCC Detail Specification No. 4003/002



**space components
coordination group**

Issue/Rev.	Date	Approved by	
		SCCG Chairman	ESA Director General or his Deputy
Issue 3	April 1994	<i>Pommes</i>	<i>J. Laub</i>
Revision 'A'	January 1997	<i>San Mill</i>	<i>A. Room</i>



ESA/SCC Detail Specification
No. 4003/002

Rev. 'A'

PAGE 2

ISSUE 3

DOCUMENTATION CHANGE NOTICE

Rev. Letter	Rev. Date	Reference	CHANGE Item	Approved DCR No.
'A'	Dec. '96		This Issue supersedes Issue 2A and incorporates all modifications agreed in DCR 221076 (rewriting of this specification). P1. Cover page P2. DCN P15. Table 3 : Items 1 and 2, in Resistance Range column, "0.1" replaced with "1.0" P18. Table 6 : Table updated P19. Table 6 : Table updated	None None 23766 23766 23766

**TABLE OF CONTENTS**

	<u>Page</u>
1. <u>GENERAL</u>	5
1.1 Scope	5
1.2 Type Variants and Range of Components	5
1.3 Maximum Ratings	5
1.4 Parameter Derating Information	5
1.5 Physical Dimensions	5
1.6 Functional Diagram	5
2. <u>APPLICABLE DOCUMENTS</u>	10
3. <u>TERMS, DEFINITIONS, ABBREVIATIONS, SYMBOLS AND UNITS</u>	10
4. <u>REQUIREMENTS</u>	10
4.1 General	10
4.2 Deviations from Generic Specification	10
4.2.1 Deviations from Special In-process Controls	10
4.2.2 Deviations from Final Production Tests	10
4.2.3 Deviations from Burn-in and Electrical Measurements	10
4.2.4 Deviations from Qualification Tests	10
4.2.5 Deviations from Lot Acceptance Tests	10
4.3 Mechanical Requirements	11
4.3.1 Dimension Check	11
4.3.2 Weight	11
4.3.3 Robustness of Terminations	11
4.4 Materials and Finishes	11
4.4.1 Housing	11
4.4.2 Terminals	11
4.4.3 Wire	11
4.5 Marking	12
4.5.1 General	12
4.5.2 The SCC Component Number	12
4.5.3 Electrical Characteristics and Ratings	12
4.5.4 Traceability Information	13
4.6 Electrical Measurements	13
4.6.1 Electrical Measurements at Room Temperature	13
4.6.2 Electrical Measurements at High and Low Temperatures	13
4.6.3 Circuits for Electrical Measurements	13
4.7 Burn-in Tests	14
4.7.1 Parameter Drift Values	14
4.7.2 Conditions for Burn-in	14
4.7.3 Electrical Circuits for Burn-in	14
4.8 Environmental and Endurance Tests	17
4.8.1 Measurements and Inspections on Completion of Environmental Tests	17
4.8.2 Measurements and Inspections at Intermediate Points during Endurance Tests	17
4.8.3 Measurements and Inspections on Completion of Endurance Tests	17
4.8.4 Conditions for Operating Life Tests	17
4.8.5 Electrical Circuits for Operating Life Tests	17
4.8.6 Conditions for High Temperature Storage Test	17

TABLES

		<u>Page</u>
1(a)	Type Variants and Range of Components	6
1(b)	Maximum Ratings	6
2	Electrical Measurements at Room Temperature	15
3	Electrical Measurements at High and Low Temperatures	15
4	Parameter Drift Values	16
5(a)	Conditions for Burn-in Test	16
5(b)	Conditions for Operating Life Test	16
6	Measurements and Inspections on Completion of Environmental Tests and at Intermediate Points and on Completion of Endurance Testing	18

FIGURES

1	Parameter Derating Information	7
2	Physical Dimensions	8
3	Functional Diagram	9
4	Circuits for Electrical Measurements	N/A
5	Electrical Circuit for Burn-in and Operating Life Tests	16

APPENDICES (Applicable to specific Manufacturers only)

None.

**1. GENERAL****1.1 SCOPE**

This specification details the ratings, physical and electrical characteristics, test and inspection data for Resistors, Fixed, Wirewound, Power-Type, Chassis-Mounted, 10W, Semi-Precision, based on Type RER65. It shall be read in conjunction with ESA/SCC Generic Specification No. 4003, the requirements of which are supplemented herein.

1.2 TYPE VARIANTS AND RANGE OF COMPONENTS

Variants of the basic type resistors and the range of components covered by this specification are given in Figure 2 and Table 1(a) respectively.

1.3 MAXIMUM RATINGS

The maximum ratings, which shall not be exceeded at any time during use or storage, applicable to the resistors specified herein, are as scheduled in Table 1(b).

1.4 PARAMETER DERATING INFORMATION

The derating information applicable to the resistors specified herein is shown in Figure 1.

1.5 PHYSICAL DIMENSIONS

The physical dimensions of the resistors specified herein are shown in Figure 2.

1.6 FUNCTIONAL DIAGRAM

The functional diagram for the resistors specified herein is shown in Figure 3.

**TABLE 1(a) - TYPE VARIANTS AND RANGE OF COMPONENTS**

Variant	Figure	Resistance Range (Note 1) R_n (Ω)	Tolerance (%)	Temperature Characteristic of Resistance ($10^{-6}/^{\circ}\text{C}$)
01	2(a)	0.1 to 0.999 1.0 to 19.99	$\pm 1.0-2.0-5.0-10$ $\pm 0.5-1.0-2.0-5.0-10$	100 (Note 2) 50 (Note 2)
02	2(b)	20 to 5620	$\pm 0.5-1.0-2.0-5.0-10$	30

NOTES

- The critical value is outside the resistance range.
- For information only for values less than 5.0Ω .

TABLE 1(b) - MAXIMUM RATINGS

NO.	CHARACTERISTIC	SYMBOL	LIMITS		UNIT	REMARKS
			MIN.	MAX		
1	Rated Dissipation for Resistors Mounted on Chassis (1)	P_n	-	10	W	See Figure 1
2	Rated Dissipation for Unmounted Resistors	P_n	-	6.0	W	See Figure 1
3	Limiting Element Voltage	U_L	-	250	V	
4	Rated Voltage Mounted on Chassis (1)	U_R	-	$\sqrt{10 R_n}$	V	At $T_{amb} = +25^{\circ}\text{C}$
5	Overload Voltage and Time Mounted on Chassis (1)	U_{over} t	-	$\sqrt{R_n}50$ 5.0	Vac s	At $T_{amb} = +25^{\circ}\text{C}$
6	Operating Temperature Range	T_{amb}	-55	+200	$^{\circ}\text{C}$	
7	Storage Temperature Range	T_{stg}	-55	+275	$^{\circ}\text{C}$	
8	Maximum Soldering Temperature	T_{sol}	-	+260	$^{\circ}\text{C}$	Soldering time: $t < 10\text{s}$.

NOTES

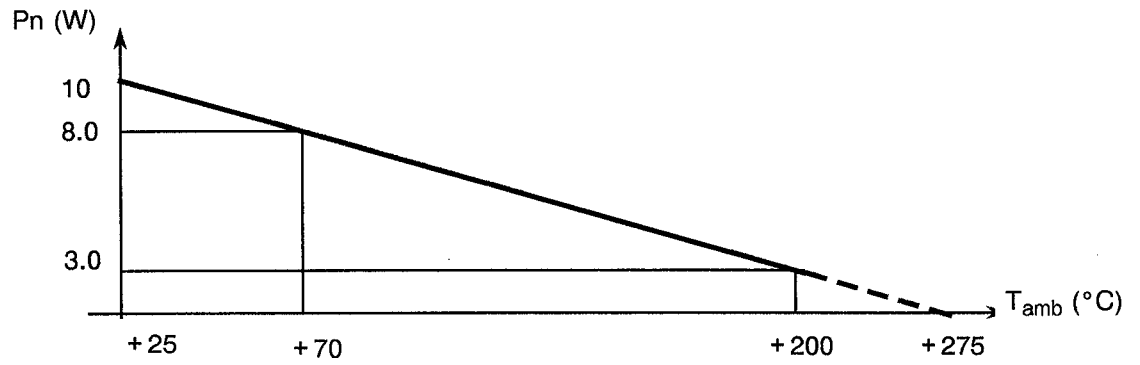
- The approximate dimensions of the chassis shall be:-

Length: 153mm
Width: 102mm
Height: 51mm
Thickness: 1.0mm
Approximate area: 400cm^2 .

See ESA/SCC Generic Specification No. 4003, Para. 9.1.1 for the mounting procedure.

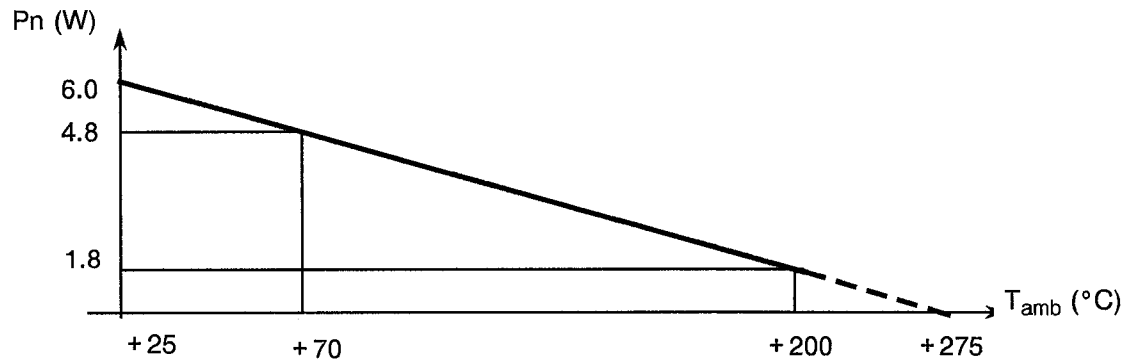


FIGURE 1 - PARAMETER DERATING INFORMATION



Rated Power versus Temperature

(For resistors mounted on chassis)



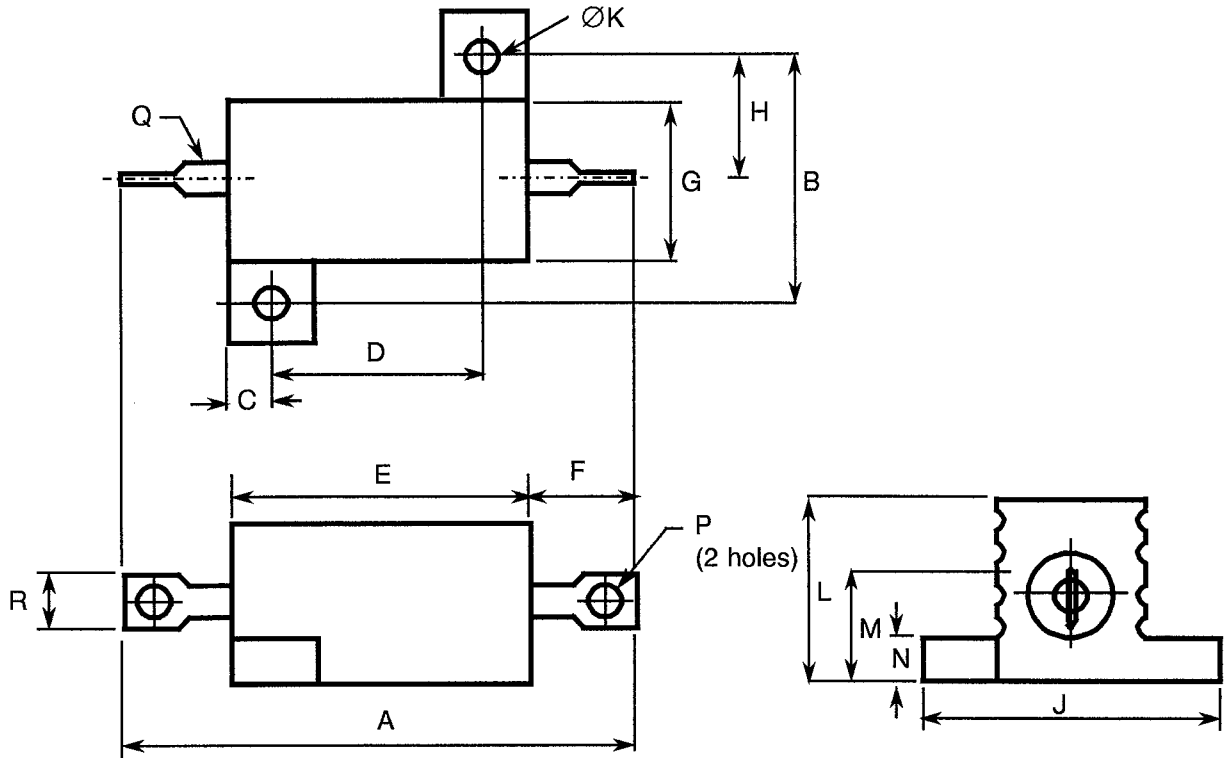
Rated Power versus Temperature

(For resistors not mounted on chassis)



FIGURE 2(a) - PHYSICAL DIMENSIONS

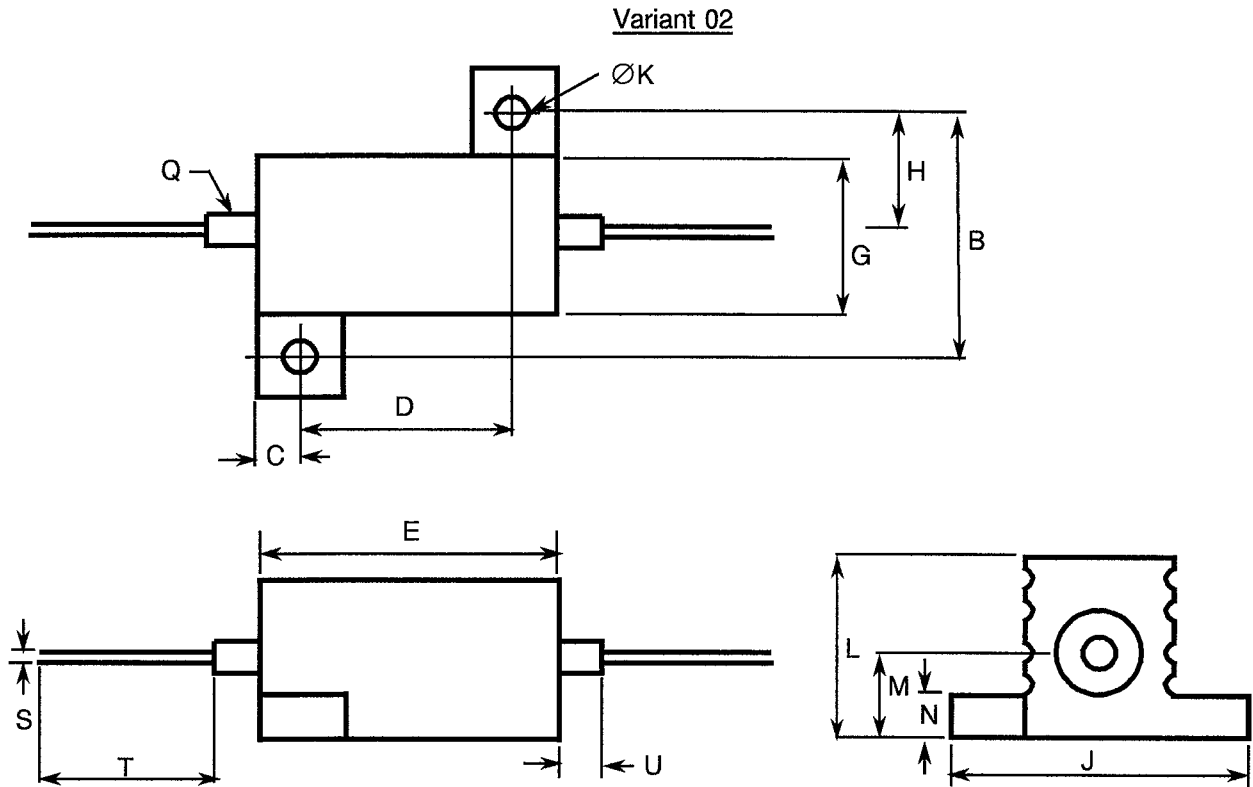
Variant 01



SYMBOL	MILLIMETRES	
	MIN.	MAX.
A	33.36	36.50
B	15.63	16.13
C	1.60	3.18
D	14.02	14.52
E	17.48	20.62
F	6.35	9.49
G	9.56	12.70
H	7.13	8.71
J	19.83	21.41
K	2.26	2.52
L	9.52	11.10
M	3.59	6.73
N	1.60	3.18
P	2.03	2.29
Q	1.95	2.15
R	3.56	-

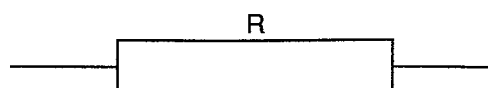




FIGURE 2 - PHYSICAL DIMENSIONS



SYMBOL	MILLIMETRES	
	MIN.	MAX.
A	-	-
B	15.63	16.13
C	1.60	3.18
D	14.02	14.52
E	17.48	20.62
G	9.56	12.70
H	7.13	8.71
J	19.83	21.41
K	2.26	2.52
L	9.52	11.10
M	3.59	6.73
N	1.60	3.18
Q	1.95	2.15
S	0.75	0.85
T	36.00	40.00
U	2.00	3.00

FIGURE 3 - FUNCTIONAL DIAGRAM



		<p style="text-align: center;">ESA/SCC Detail Specification No. 4003/002</p>	<p>PAGE 10 ISSUE 3</p>
--	--	--	----------------------------

2. APPLICABLE DOCUMENTS

The following documents form part of this specification and shall be read in conjunction with it:-

- (a) ESA/SCC Generic Specification No. 4003, Resistors, Fixed, Wirewound, Power-type, Chassis-Mounted.
- (b) ESA/SCC Basic Specification No. 23500, Requirements for Lead Materials and Finishes for Components for Space Application.

3. TERMS, DEFINITIONS, ABBREVIATIONS, SYMBOLS AND UNITS

For the purpose of this specification, the terms, definitions, abbreviations, symbols and units specified in ESA/SCC Basic Specification No. 21300 shall apply. In addition, the following symbols are used:-

- I_T - Test current.
- R_A - Resistance value measured at ambient temperature ($+ 22 \pm 3$ °C).
- R_i - Insulation resistance.
- TCR - Temperature characteristic of resistance.
- U_T - Test voltage.
- U_{proof} - d.c. or r.m.s. voltage proof.
- U_{overl} - Overload voltage.

4. REQUIREMENTS

4.1 GENERAL

The complete requirements for procurement of the resistors specified herein shall be as stated in this specification and ESA/SCC Generic Specification No. 4003 for Resistors, Fixed, Wirewound. Deviations from the Generic Specification, applicable to this specification only, are detailed in Para. 4.2.

Deviations from the applicable Generic Specification and this Detail Specification, formally agreed with specific Manufacturers on the basis that the alternative requirements are equivalent to the ESA/SCC requirement and do not affect the components' reliability, are listed in the appendices attached to this specification.

4.2 DEVIATIONS FROM GENERIC SPECIFICATION

4.2.1 Deviations from Special In-process Controls

None.

4.2.2 Deviations from Final Production Tests (Chart II)

None.

4.2.3 Deviations from Burn-in and Electrical Measurements (Chart III)

None.

4.2.4 Deviations from Qualification Tests (Chart IV)

- (a) Para. 9.18, Maximum Time Constant: Not applicable.

4.2.5 Deviations from Lot Acceptance Tests (Chart V)

- (a) Para. 9.18, Maximum Time Constant: Not applicable.



4.3 MECHANICAL REQUIREMENTS

4.3.1 Dimension Check

The dimensions of the resistors specified herein shall be specified in accordance with the requirements set out in Para. 9.3 of ESA/SCC Generic Specification No. 4003 and they shall conform to those shown in Figure 2 of this specification.

4.3.2 Weight

The maximum weight of the resistors specified herein shall be 8.8 grams.

4.3.3 Robustness of Terminations

The requirements for robustness of termination testing are specified in Para. 9.10 of ESA/SCC Generic Specification No. 4003. The test conditions shall be as follows:-

Variant 01

Test Condition : Ua

Applied Force : 20N

Variant 02

Test Condition : Ua, Ub or Uc

Applied Force for test condition Ua: 10N

4.4 MATERIALS AND FINISHES

The materials and finishes shall be as specified herein. Where a definite material is not specified, a material which will enable the resistors specified herein to meet the performance requirements of this specification shall be used. Acceptance or approval of any constituent material does not guarantee acceptance of the finished product.

4.4.1 Housing

The housing shall be made from an aluminium alloy and shall be protected against corrosion. All fasteners shall be suitably plated.

4.4.2 Terminals

Variant 01

The terminals shall be type 'C4' in accordance with the requirements of ESA/SCC Basic Specification No. 23500.

Variant 02

The terminals shall be type 'B3' in accordance with the requirements of ESA/SCC Basic Specification No. 23500.

4.4.3 Wire

Each resistor shall be wound with a conductor having no joints, welds or bonds within each terminated resistance element, except at the end terminals. In no case shall the nominal diameter be less than 25µm. For wires with a nominal diameter of less than 60µm, no abrasion with the view of achieving the required resistance tolerance, is allowed. For diameters equal to or greater than that above, the abrasion, if performed, must be evenly distributed around the resistor body. The remaining cross-sectional area of the wire after the abrading operation shall be at least 90% of the original cross-sectional area.



4.5 MARKING

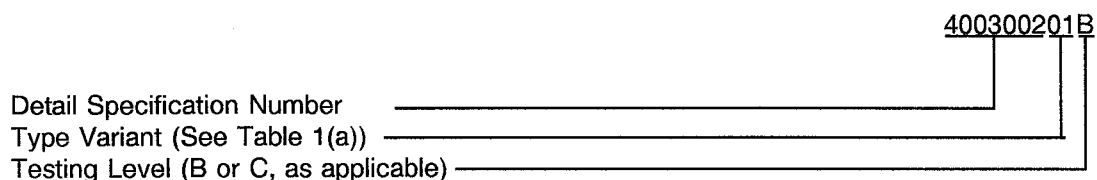
4.5.1 General

The marking of all components delivered to this specification shall be in accordance with ESA/SCC Basic Specification No. 21700 and the following paragraphs. Each component shall be marked in respect of:-

- (a) The SCC Component Number.
- (b) Electrical Characteristics and Ratings.
- (c) Traceability Information.

4.5.2 The SCC Component Number

The SCC Component Number shall be constituted and marked as follows:

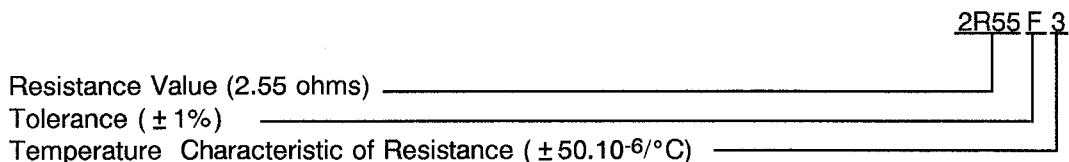


4.5.3 Electrical Characteristics and Ratings

The electrical characteristics and ratings to be marked in the following order of precedence are:-

- (a) Numerical value.
- (b) Tolerance.
- (c) Temperature coefficient.

The information shall be constituted and marked as follows:-



4.5.3.1 Resistance Values

Resistance values shall be expressed by means of the following codes.

The unit quantity for marking shall be Ohms.

RESISTANCE VALUE	CODE
0.0XX	R0XX
0.XXX	RXXX
X.XX	XRXX
XX.X	XXRX
XXX	XXX0
XXX 10 ¹	XXX1

For values of 100 and above, the first three digits (X) represent significant figures and the last digit specifies the number of zeros to follow.

When values of less than 100 are required, the letter 'R' is used to indicate the decimal point. When the letter is used, all succeeding digits represent significant figures.



4.5.3.2 Tolerance

The tolerances on numerical values shall be indicated by the letter codes specified hereafter:-

TOLERANCE (%)	CODE LETTER
± 0.5	D
± 1.0	F
± 2.0	G
± 5.0	J
± 10	K

4.5.3.3 Temperature Characteristic of Resistance

The temperature characteristic of resistance shall be indicated by the numerical codes specified hereafter:-

DIGIT	TEMPERATURE CHARACTERISTIC OF RESISTANCE $\pm 10^{-6} / ^\circ\text{C}$
9	30
3	50
4	100

4.5.4 Traceability Information

Traceability information shall be marked in accordance with ESA/SCC Basic Specification No. 21700.

4.6 ELECTRICAL MEASUREMENTS

4.6.1 Electrical Measurements at Room Temperature

The parameters to be measured at room temperature are scheduled in Table 2. The measurements shall be performed at $T_{\text{amb}} = +22 \pm 3 ^\circ\text{C}$.

4.6.2 Electrical Measurements at High and Low Temperatures

The parameters to be measured on a sample basis at high and low temperatures are scheduled in Table 3. AQL shall be 0.65% (Level II) out of the total production lot. The distribution of the sample shall be as follows:-

- 1/3 with lowest resistance values.
- 1/3 with median resistance values.
- 1/3 with highest resistance values.

4.6.3 Circuits for Electrical Measurements (Figure 4)

Not applicable.



4.7 BURN-IN TESTS

4.7.1 Parameter Drift Values

The parameter drift values applicable to burn-in are specified in Table 4 of this specification. Measurements shall be performed at $T_{amb} = +22 \pm 3$ °C. The parameter drift values (Δ) applicable to the parameter scheduled shall not be exceeded. In addition to these drift value requirements for a given parameter, the appropriate limit value specified in Table 2 shall not be exceeded.

4.7.2 Conditions for Burn-in

The requirements for burn-in are specified in Section 7 of ESA/SCC Generic Specification No. 4003. The conditions for burn-in shall be as specified in Table 5(a). Resistors shall be tested with a d.c. voltage with a ripple not exceeding 5%. A voltage of $\sqrt{6R_n}$ (see Figure 5), shall be applied in cycles of 90 minutes "on" and 30 minutes "off" throughout the test. The resistors shall be connected by their terminations to suitable clips on a rack of insulating material.

The resistors shall be so arranged that the temperature of any one resistor does not appreciably influence the temperature of any other resistor. There shall be no undue draught over the resistors. After the period specified in the Generic Specification, the resistors shall be removed from the chamber and allowed to cool under normal atmospheric conditions for a minimum of 4 hours.

4.7.3 Electrical Circuits for Burn-in

The circuit for use in performing the burn-in tests is shown in Figure 5.

TABLE 2 - ELECTRICAL MEASUREMENTS AT ROOM TEMPERATURE

No.	Characteristic	Symbol	Spec. and/or Test Method	Test Conditions	Tolerance (%)	Limits		Unit
						min	Max	
1	Resistance	R_A	ESA/SCC Generic Spec. No. 4003	Para. 9.5.1.1	0.5	$0.995 R_n$	$1.005 R_n$	Ω
					1.0	$0.99 R_n$	$1.01 R_n$	
					2.0	$0.98 R_n$	$1.02 R_n$	
					5.0	$0.95 R_n$	$1.05 R_n$	
					10	$0.90 R_n$	$1.10 R_n$	
2	Insulation Resistance (Note 1)	R_i	ESA/SCC Generic Spec. No. 4003	Para. 9.5.1.2	-	10 000	-	M Ω
3	Voltage Proof (Note 1)	V_p	ESA/SCC Generic Spec. No. 4003	Para. 9.5.1.3	-	1 000	-	V _{rms}

NOTES

- Measurements on a sample basis; sample size as specified in Para. 4.6.2.

TABLE 3 - ELECTRICAL MEASUREMENTS AT HIGH AND LOW TEMPERATURES

No.	Characteristic	Symbol	Spec. and/or Test Method	Test Conditions	Resistance Range (Ω)	Limits		Unit
						Min	Max	
1	Resistance Change between -55(+3 - 0) °C and +22 ± 3 °C	$\Delta R/R$	ESA/SCC Generic Spec. No. 4003	Para. 9.5.1.1	$R_n \leq 1.0$	-0.8	+0.8	%
					$1.0 < R_n < 19.99$	-0.4	+0.4	
					$R_n > 20$	-0.25	+0.25	
2	Resistance Change between +175(+0-3) °C and +22 ± 3 °C	$\Delta R/R$	ESA/SCC Generic Spec. No. 4003	Para. 9.5.1.1	$R_n \leq 1.0$	-1.5	+1.5	%
					$1.0 < R_n < 19.99$	-0.75	+0.75	
					$R_n > 20$	-0.45	+0.45	

**TABLE 4 - PARAMETER DRIFT VALUES**

NO.	CHARACTERISTIC	SYMBOL	SPEC. AND/OR TEST METHOD	TEST CONDITIONS	CHANGE LIMITS (Δ)	UNIT
1	Resistance Change	$\Delta R/R$	As per Table 2	As per Table 2	± 0.3 or (1) ± 0.05	% Ω

NOTES

1. Whichever is the greater.

FIGURE 4 - CIRCUITS FOR ELECTRICAL MEASUREMENTS

Not applicable.

TABLE 5(a) - CONDITIONS FOR BURN-IN TEST

NO.	CHARACTERISTIC	SYMBOL	CONDITION	UNIT
1	Temperature for Initial Measurement	T_{amb}	$+22 \pm 3$	$^{\circ}C$
2	Temperature for Burn-in Test	T_{amb}	$+25 \pm 10$	$^{\circ}C$
3	Voltage applied, Unmounted Resistors	U_T (1)	$\sqrt{6 R_n}$	Vdc or Vrms
4	Temperature for Final Measurement	T_{amb}	$+22 \pm 3$	$^{\circ}C$

NOTES

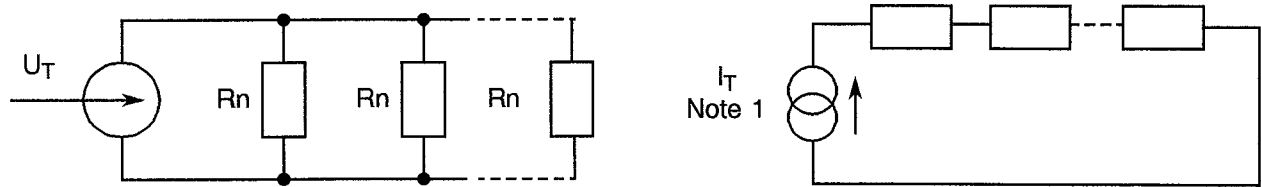
1. Or I_T (See Figure 5).

TABLE 5(b) - CONDITIONS FOR OPERATING LIFE TEST

NO.	CHARACTERISTIC	SYMBOL	CONDITION	UNIT
1	Temperature for Initial Measurement	T_{amb}	$+22 \pm 3$	$^{\circ}C$
2	Temperature for Operating Life Test	T_{amb}	$+25 \pm 10$	$^{\circ}C$
3	Voltage applied, Mounted on Chassis	U_T (1)	$\sqrt{10 R_n}$	Vdc or Vrms
4	Temperature for Final Measurement	T_{amb}	$+22 \pm 3$	$^{\circ}C$

NOTES

1. Or I_T (See Figure 5).

**FIGURE 5 - ELECTRICAL CIRCUIT FOR BURN-IN AND OPERATING LIFE TESTS****NOTES**

1. $I_T = \sqrt{\frac{6}{R_n}}$ for burn-in. $I_T = \sqrt{\frac{10}{R_n}}$ for life test.

4.8 ENVIRONMENTAL AND ENDURANCE TESTS (CHARTS IV AND V OF ESA/SCC GENERIC SPECIFICATION NO. 4003)

4.8.1 Measurements and Inspections on Completion of Environmental Tests

The parameters to be measured and inspections to be performed on completion of environmental tests are scheduled in Table 6. The measurements shall be performed at $T_{amb} = +22 \pm 3$ °C.

4.8.2 Measurements and Inspections at Intermediate Points during Endurance Tests

The parameters to be measured and inspections to be performed at intermediate points during endurance tests are scheduled in Table 6. The measurements shall be performed at $T_{amb} = +22 \pm 3$ °C.

4.8.3 Measurements and Inspections on Completion of Endurance Tests

The parameters to be measured and inspections to be performed on completion of endurance tests are scheduled in Table 6. Unless otherwise stated, the measurements shall be performed at $T_{amb} = +22 \pm 3$ °C.

4.8.4 Conditions for Operating Life Tests (Part of Endurance Testing)

The requirements for operating life testing are specified in Section 9 of ESA/SCC Generic Specification No. 4003. The conditions for operating life testing shall be as specified in Table 5(b) of this specification.

4.8.5 Electrical Circuits for Operating Life Tests

The circuits for use in performing the operating life tests are shown in Figure 5.

4.8.6 Conditions for High Temperature Storage Test (Part of Endurance Testing)

The requirements for the high temperature storage test are specified in Section 9 of ESA/SCC Generic Specification No. 4003. The temperature to be applied shall be the maximum storage temperature specified in Table 1(b) of this specification.



TABLE 6 - MEASUREMENTS AND INSPECTIONS ON COMPLETION OF ENVIRONMENTAL TESTS AND AT INTERMEDIATE POINTS AND ON COMPLETION OF ENDURANCE TESTING

NO.	ESA/SCC GENERIC SPEC. No. 4003		MEASUREMENTS AND INSPECTIONS		SYMBOL	LIMITS		UNIT
	ENVIRONMENTAL AND ENDURANCE TESTS (1)	TEST METHOD AND CONDITIONS	IDENTIFICATION	CONDITIONS		MIN.	MAX.	
01	Overload	Para. 9.1 and Table 1(b) of this specification	Initial Measurements Resistance Final Measurements Visual Examination Resistance Change	Table 2 Item 1 After 1 to 2 hrs recovery No damage Legible marking Table 2 Item 1	R_A - $\Delta R_A/R_A$	Table 2 Item 1 - $\pm [0.3 + (0.05\Omega/R)]$	- - %	
02	Permanence of Marking	Para. 9.6	Final Measurements Visual Examination	No corrosion or obliteration of marking	-	-	-	
03	Temperature Characteristic of Resistance	Para. 9.7 Procedure II	During Test Temperature Characteristic of Resistance	Para. 9.7.3 of ESA/SCC No. 4003	TCR	Table 1(a)	$10^{-6}/^{\circ}\text{C}$	
04	Voltage Proof (Altitude)	Para. 9.8 500Vrms	Initial Measurements Resistance During Test Visual Examination Final Measurements Resistance Change	Table 2 Item 1 At Reduced Pressure 8mm Mercury No Breakdown or Flashover Table 2 Item 1	R_A - $\Delta R_A/R_A$	Table 2 Item 1 - $\pm [0.2 + (0.05\Omega/R)]$	- - %	
05	Solderability	Para. 9.9 Procedure II	Final Measurements Visual Examination	No damage Legible marking	-	-	-	
06	Robustness of Terminations	Para 9.10 and Para. 4.3.3 of this specification	Initial Measurements Resistance Final Measurements Visual Examination Resistance Change	Table 2 Item 1 No damage Table 2 Item 1	R_A - $\Delta R_A/R_A$	Table 2 Item 1 - $\pm [0.2 + (0.05\Omega/R)]$	- - %	
07	Resistance to Soldering Heat	Para. 9.11 Procedure I	Initial Measurements Resistance Final Measurements Visual Examination Resistance Change	Table 2 Item 1 After 24 ± 4 hours recovery No damage Legible marking Table 2 Item 1	R_A - $\Delta R_A/R_A$	Table 2 Item 1 - $\pm [0.3 + (0.05\Omega/R)]$	- - %	
08	Rapid Change of Temperature	Para. 9.12 and Table 1(b) of this spec.	Initial Measurements Resistance Final Measurements Visual Examination Resistance Change	Table 2 Item 1 After 1 to 2 hrs recovery No damage Table 2 Item 1	R_A - $\Delta R_A/R_A$	Table 2 Item 1 - $\pm [0.5 + (0.05\Omega/R)]$	- - %	
09	Vibration	Para. 9.13	Initial Measurements Resistance Final Measurements Visual Examination Resistance Change	Table 2 Item 1 No damage Table 2 Item 1	R_A - $\Delta R_A/R_A$	Table 2 Item 1 - $\pm [0.2 + (0.05\Omega/R)]$	- - %	

NOTES

1. The tests in this Table refer to either Chart IV or V and shall be used as applicable.



TABLE 6 - MEASUREMENTS AND INSPECTIONS ON COMPLETION OF ENVIRONMENTAL TESTS AND AT INTERMEDIATE POINTS AND ON COMPLETION OF ENDURANCE TESTING (CONT'D)

NO.	ESA/SCC GENERIC SPEC. NO. 4003		MEASUREMENTS AND INSPECTIONS		SYMBOL	LIMITS		UNIT
	ENVIRONMENTAL AND ENDURANCE TESTS (1)	TEST METHOD AND CONDITIONS	IDENTIFICATION	CONDITIONS		MIN.	MAX.	
10	Climatic Sequence	Para. 9.14 Procedure I	Initial Measurements Resistance Final Measurements Resistance Change Insulation Resistance	After Drying Table 2 Item 1 After 1 to 2 hrs recovery Table 2 Item 1 Table 2 Item 2	R_A $\Delta R_A/R_A$ R_i	Table 2 Item 1 $\pm [1.0 + (0.05\Omega/R)]$ 1000	-	% M Ω
11	Operating Life	Para. 9.15 Chart IV	Initial Measurements Resistance Intermediate Measurements Resistance Change Final Measurements Resistance Change	Table 2 Item 1 1000 \pm 48 hrs After 1 to 2 hrs recovery Table 2 Item 1 2000 \pm 48 hrs After 1 to 2 hrs recovery Table 2 Item 1	R_A $\Delta R_A/R_A$ $\Delta R_A/R_A$	Table 2 Item 1 $\pm [0.8 + (0.05\Omega/R)]$ $\pm [1.0 + (0.05\Omega/R)]$	-	% %
		Para. 9.15 Chart V	Initial Measurements Resistance Final Measurements Resistance Change	Table 2 Item 1 1000 \pm 48 hrs After 1 to 2 hrs recovery Table 2 Item 1	R_A $\Delta R_A/R_A$	Table 2 Item 1 $\pm [0.8 + (0.05\Omega/R)]$	-	%
12	High Temperature Storage	Para. 9.16	Initial Measurements Resistance Intermediate Measurements Resistance Change Final Measurements Resistance Change	Table 2 Item 1 1000 \pm 48 hrs Table 2 Item 1 2000 \pm 48 hrs Table 2 Item 1	R_A $\Delta R_A/R_A$ $\Delta R_A/R_A$	Table 2 Item 1 $\pm [0.8 + (0.05\Omega/R)]$ $\pm [1.0 + (0.05\Omega/R)]$	-	% %
			13	External Visual Inspection	Para. 9.17	Visual Inspection	ESA/SCC No. 20500	-
14	Maximum Time Constant (Not applicable to inductive resistors)	Para. 9.18 and Paras 4.2.4 and 4.2.5 of this spec.	Not applicable					

NOTES: See Page 18.