




**INTERNAL VISUAL INSPECTION OF
SURFACE ACOUSTIC WAVE (SAW) DEVICES
ESCC Basic Specification No. 2043502**

**ISSUE 1
October 2002**



	ESCC Basic Specification		PAGE ii ISSUE 1
---	--------------------------	--	--------------------

LEGAL DISCLAIMER AND COPYRIGHT

European Space Agency, Copyright © 2002. All rights reserved.

The European Space Agency disclaims any liability or responsibility, to any person or entity, with respect to any loss or damage caused, or alleged to be caused, directly or indirectly by the use and application of this ESCC publication.

This publication, without the prior permission of the European Space Agency and provided that it is not used for a commercial purpose, may be:

- copied in whole in any medium without alteration or modification.
- copied in part, in any medium, provided that the ESCC document identification, comprising the ESCC symbol, document number and document issue, is removed.



europaean space agency
agence spatiale européenne

Pages 1 to 16

**INTERNAL VISUAL INSPECTION OF
SURFACE ACOUSTIC WAVE (SAW) DEVICES
ESA/SCC Basic Specification No. 2043502**



**space components
coordination group**

Issue/Rev.	Date	Approved by	
		SCCG Chairman	ESA Director General or his Deputy
Issue 1	September 1994		



ESA/SCC Basic Specification
No. 2043502

PAGE 2

ISSUE 1

DOCUMENTATION CHANGE NOTICE

Rev. Letter	Rev. Date	Reference	CHANGE Item	Approved DCR No.

**TABLE OF CONTENTS**

	<u>Page</u>
1. <u>SCOPE</u>	4
2. <u>GENERAL REQUIREMENTS</u>	4
2.1 Applicability	4
2.2 Procedure	4
2.3 Magnification	4
2.4 Mounting Fixtures	4
3. <u>DETAILED REQUIREMENTS</u>	4
3.1 General	4
3.2 SAW Substrate Defects	4
3.3 Metallisation Defects	4
3.4 Header Defects and Presence of Foreign Material	5
3.4.1 Header	5
3.4.2 Substrate Adhesive	5
3.4.3 Acoustic Absorber Wedge	5
3.5 Assembly Defects	5
3.5.1 Substrate	5
3.5.2 Wire-bonding	5
3.5.3 Wire Bond Defects	6
3.5.4 Tape Bonding	7
3.5.5 Tape Bond Defects	8
<u>FIGURES</u>	
I Typical SAW Device	8
II Lead Eccentricity and Tilt	9
III Twisted Wire	9
IV Wire or Tape Deformity	10
V Bowed Wire or Tape	10
VI Wire or Tape Trajectories	11
VII Ball Bond Wire Trajectory	12
VIII Ball Bonds	13
IX Torn and Incomplete Bonds	14
X Lifted Pin Bonds	15
XI Loop between Double Bond	16

**1. SCOPE**

This specification, to be read in conjunction with ESA/SCC Basic Specification No. 20400, 'Internal Visual Inspection', contains additional specific requirements for Surface Acoustic Wave (SAW) Devices.

They shall apply, where relevant, to each component inspected.

2. GENERAL REQUIREMENTS**2.1 APPLICABILITY**

The following criteria may not be varied or modified after commencing any inspection stage. Any ambiguity or proposed minor deviation shall be referred to the Qualifying Space Agency for resolution and approval.

2.2 PROCEDURE

All components shall be submitted to examination immediately prior to sealing or encapsulation, or immediately after decapping, in an area where the standard of cleanliness is not less than that of the assembly area.

All items shall be examined in such a manner that a minimum of handling and movement of the component is involved.

2.3 MAGNIFICATION

All items shall be examined with a binocular or stereoscopic microscope under a magnification of X15 to X20.

2.4 MOUNTING FIXTURES

Suitable fixtures may be used to assist in the inspection process provided they do not of themselves cause damage to the device.

3. DETAILED REQUIREMENTS**3.1 GENERAL**

A component shall be rejected if it exhibits one or more of the defects listed in any of the following paragraphs.

3.2 SAW SUBSTRATE DEFECTS

- (a) Cracks in unmetallised active area.
- (b) Chip-outs on the polished upper surface.
- (c) Scratches on the polished upper surface.
- (d) Stains on the polished upper surface.
- (e) Foreign matter on the polished upper surface.
- (f) Notches such as that future cracks are possible.

3.3 METALLISATION DEFECTS

- (a) Superfluous metallisation on the substrate surface.
- (b) Pin-holes (a pin-hole is a hole whose surface is greater than or equal to 0.1mm²).
- (c) Scratches.



- (d) Bubbles or depressions.
- (e) Lifiting of metallisation or peeling.
- (f) Oxidation or other discoloration.
- (g) Foreign materials.

3.4 HEADER DEFECTS AND PRESENCE OF FOREIGN MATERIAL

3.4.1 Header (see Figure I)

- (a) Any loose or foreign material on the mating surfaces or top of the header.
- (b) Any surface plating material showing evidence of blistering or flaking.
- (c) Any metal shavings.
- (d) Bent or deformed header mating surfaces.
- (e) Plating overlapping the glass seals.
- (f) Cracked or chipped glass seals.
- (g) Non-uniformity of finish of lead, particularly at the glass seal.
- (h) Nicks or bulges in the lead diameter outside the stated lead tolerances.
- (i) Bubbles in the seal area.
- (j) Foreign particles enclosed in the glass seal.
- (k) Eccentricity of the lead passing through the centre of the glass-to-metal seal greater than 10% of the seal diameter (see Figure II).
- (l) Lead tilted by more than 5 degrees (see Figure II).

3.4.2 Substrate Adhesive

- (a) Adhesive not extending to the outer edges of the substrate underside.
- (b) Single voids in the adhesive larger than 5% of the total substrate area.
- (c) Total area of all voids exceeding 12.5% of the total substrate area.

3.4.3 Acoustic Absorber Wedge

- (a) Incorrectly shaped and located (as detailed in the P.I.D.).
- (b) Obtrusion onto the active area (as detailed in the P.I.D.).
- (c) Flowing over the sides or ends of the substrate.

3.5 ASSEMBLY DEFECTS

3.5.1 Substrate

Incorrect location and orientation (as defined in the P.I.D.).

3.5.2 Wire-bonding

3.5.2.1 General

Wire-bonding operations shall be carried out such that the wire is carried from the bond in a smooth trajectory without mechanical stress.

The number, type and location of the wire bonds (as defined in the P.I.D.) shall be verified.



3.5.2.2 Deformed Wire

- (a) Wire twisted more than 360° from substrate bond to pin bond or showing any sharp kink (see Figure III).
- (b) Any nicks, cuts, scratches or other deformity which reduces the wire diameter by more than 25% (see Figure IV).

3.5.2.3 Bowed Wire (see Figure V)

- (a) Wire less than 125 microns diameter bowed more than 7 wire diameters.
- (b) Wire greater than 125 microns diameter bowed more than 3 wire diameters.

3.5.2.4 Bond Trajectories (see Figure VI)

- (a) Wire clearing the edge of the substrate by less than 75 microns or 1 wire diameter, whichever is the greater.
- (b) Wire rising above the level of the higher bond by more than 500 microns or 10 wire diameters, whichever is the less.
- (c) Wire trajectory having a point of inflection other than in the immediate vicinity of the bond.

3.5.3 Wire-bond Defects

3.5.3.1 General

- (a) Black or purple plague or other corrosion around the bond perimeter or on the metallisation.
- (b) Bonds placed such that the wire exiting from the bond crosses over (when viewed from above) or is less than 0.05mm from another unpassivated wire or bond, unless electrically common.
- (c) Evidence of wire burns.
- (d) Lifted bonds (see Figure X).
- (e) Bonds on the package pin (when viewed from above) which are not completely within the boundaries of the package pin.

3.5.3.2 Ball Bonds (see Figure VII)

- (a) Lifted bonds.
- (b) Less than two thirds of the ball in contact with the substrate.
- (c) Wire terminating on the perimeter of the ball when viewed from above (see Figure VIII).
- (d) Wire of which the diameter at the ball is reduced by more than 25% (see Figure VIII).
- (e) Ball diameter, viewed from above, less than 3 times the wire diameter or more than 7 times the wire diameter (see Figure VIII).
- (f) Ball height, viewed from the side, less than 1 wire diameter or more than 3 times the wire diameter.

3.5.3.3 Ultrasonic and Thermocompression Wedge Bonds

- (a) Substrate bond torn in bond area or behind the bond (see Figure IX).
- (b) Nicks in the side of the bond or holes in the centre of the bond (see Figure IX).



- (c) Tool impression area lifted more than 25% (see Figure IX).
- (d) If the bond is smaller than the substrate pad area, less than 75% of the tool impression appearing on the area of the substrate pad.
- (e) If the bond is larger than the substrate pad area, less than 50% of the tool impression appearing on the area of the substrate pad.
- (f) Wedge bond width less than 1.2 or more than 3 wire diameters or length less than 1.5 or more than 5 wire diameters.
- (g) Crescent bond width less than 1.2 or more than 5 wire diameters or length less than 0.5 or more than 3 wire diameters.
- (h) Wire tails exceeding 2 wire diameters at the substrate or extra pigtails or no pigtail at the substrate.
- (i) Loops between double bonds greater than 4 wire diameters (see Figure XI).
- (j) Where crescent bonds are formed on top of ball bonds, the crescent bond width less than 1.2 or more than 5 wire diameters or length less than 0.5 or more than 3 wire diameters. The criteria for the lower ball bond remain the same as in Para. 3.5.3.2.

3.5.4 Tape Bonding

3.5.4.1 General

For the purposes of this specification, tape is defined as a strip of material which is at least 5 times as wide as it is thick and has a minimum thickness of 25 microns.

Tape bonding operations shall be carried out such that the tape is carried from the bond in a smooth trajectory without mechanical stress. The number, type and location of the tape bonds (as defined in the P.I.D.) shall be verified.

3.5.4.2 Deformed Tape

- (a) Tape twisted between bonds or showing any sharp kink.
- (b) Any nicks, cuts, scratches or other deformity which reduces the tape width by more than 25% (see Figure IV).

3.5.4.3 Bowed Tape (see Figure V)

- (a) Tape less than 125 microns thick bowed more than 5 tape thicknesses.
- (b) Tape greater than 125 microns thick bowed more than 2 tape thicknesses.

3.5.4.4 Bond Trajectories (see Figure VI)

- (a) Tape clearing the edge of the substrate by less than 75 microns or 1 tape thickness, whichever is the greater.
- (b) Tape rising above the level of the higher bond by more than 1.5mm or 30 tape thicknesses, whichever is the less.
- (c) Tape trajectory having a point of inflection other than in the immediate vicinity of the bond.



3.5.5 Tape Bond Defects

3.5.5.1 General

- (a) Black or purple plague, grey deposits or other corrosion around the bond perimeter or on the metallisation.
- (b) Bond placed such that the tape exiting from the bond crosses over (when viewed from above) or is less than 50 microns from another unpassivated tape or bond, unless electrically common.
- (c) Evidence of tape burns.
- (d) Lifted bonds (see Figure X).

3.5.5.2 Tape Bonds

- (a) Bonds which do not exhibit two readily visible bond impressions on the area of tape overlapping underlying metallisation.
- (b) Bond torn in the bond area or behind the bond (see Figure IX).
- (c) Nicks in the side of the bond or holes in the centre of the bond (see Figure IX).
- (d) Tool impression area lifted more than 25% (see Figure IX).
- (e) Less than 75% of the tool impression appears on the area of the substrate pad or package pin.
- (f) Bond tails that extend over or make contact with any non-insulated metallisation not connected to the tape.
- (g) Tape bond tails exceeding half of the tape width.

FIGURE I - TYPICAL SAW DEVICE

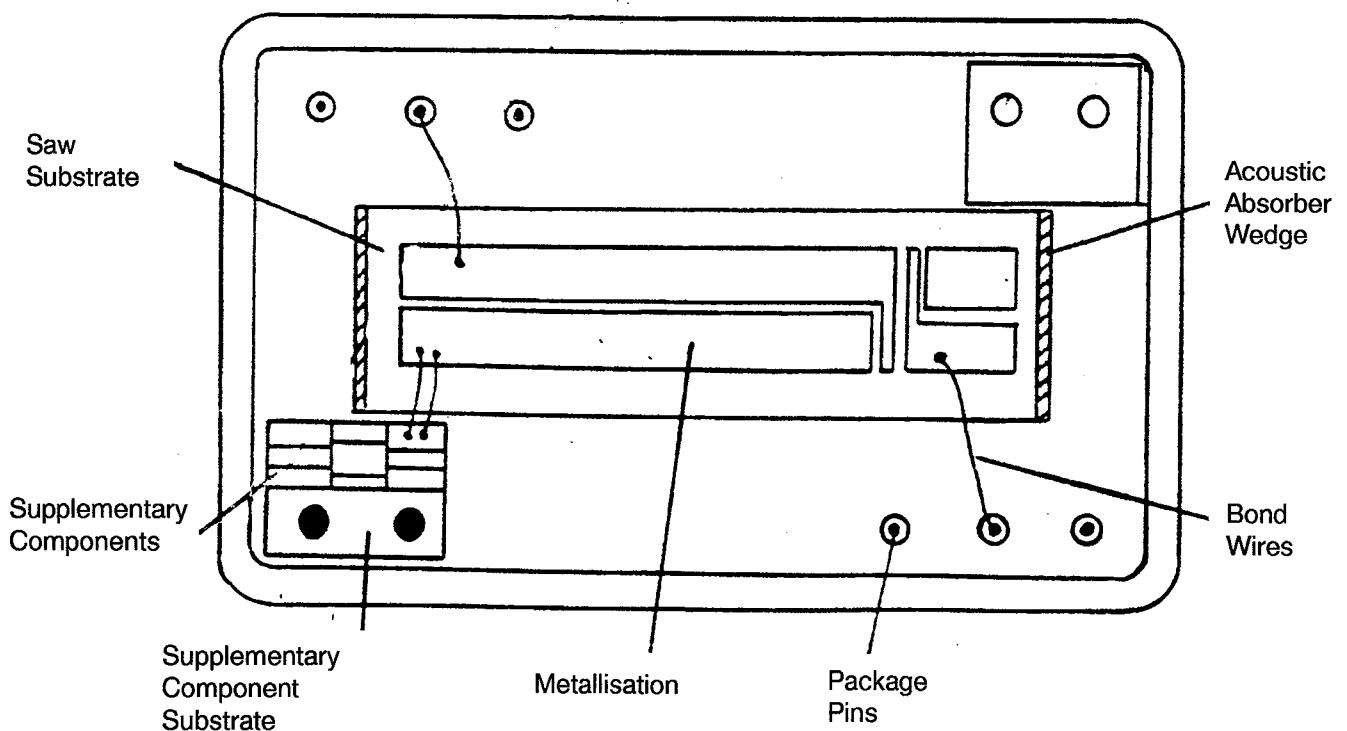
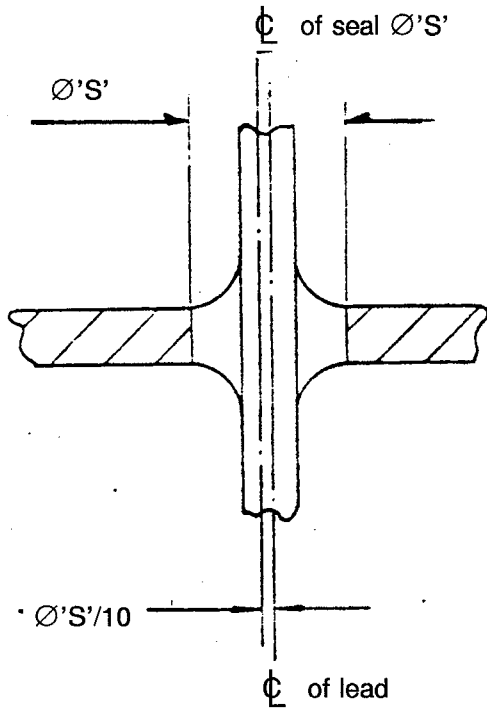




FIGURE II - LEAD ECCENTRICITY AND TILT

LEAD ECCENTRICITY



LEAD TILT

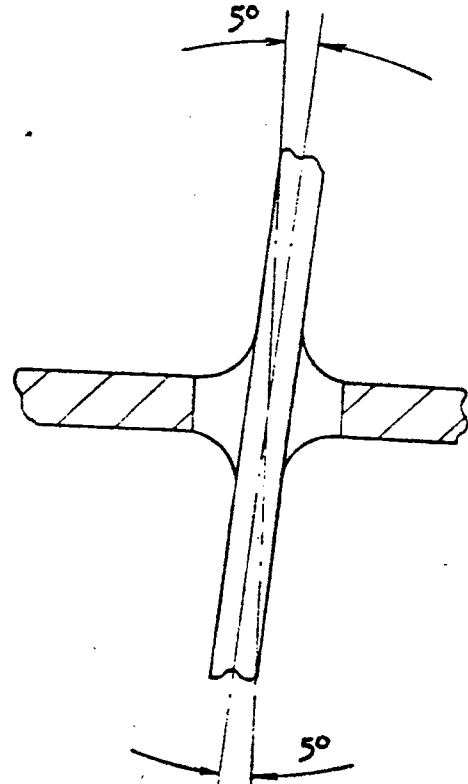
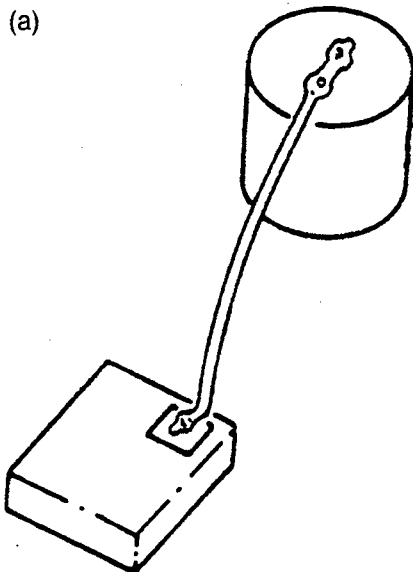
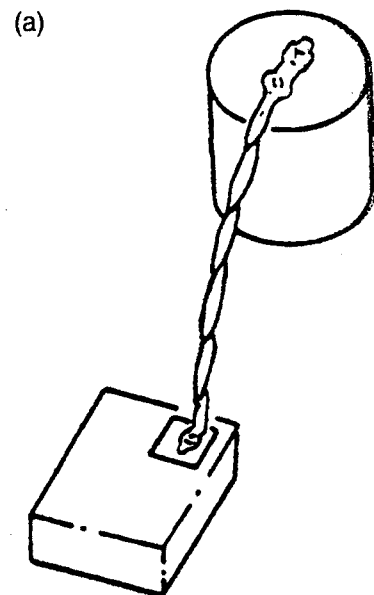


FIGURE III - TWISTED WIRE



ACCEPT
No twist in the wire.



REJECT
Wire is twisted 360° from substrate bond to pin bond.



FIGURE IV - WIRE OR TAPE

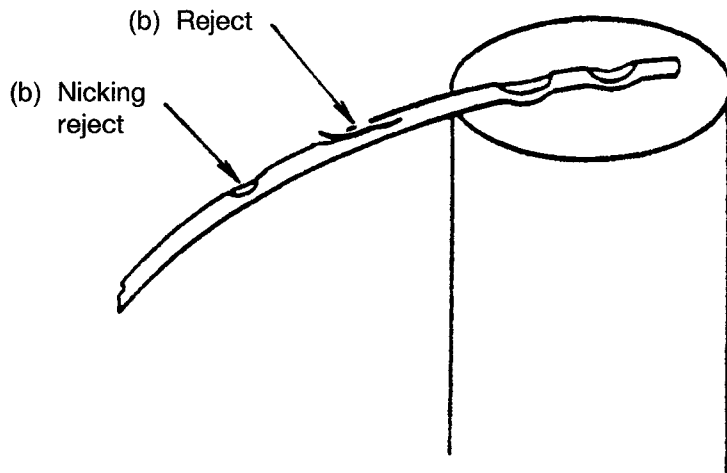
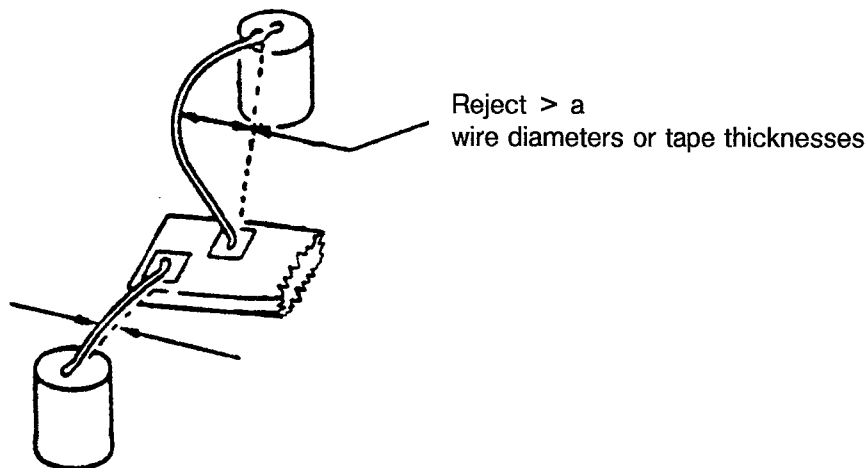


FIGURE V - BOWED WIRE OR TAPE



WIRE:

Accept $< a$
wire diameters

$a = 7$ when wire dia $< 125\mu\text{m}$

$a = 3$ when wire dia $> 125\mu\text{m}$

TAPE:

Accept $< a$
tape thickness

$a = 5$ when tape thickness $< 125\mu\text{m}$

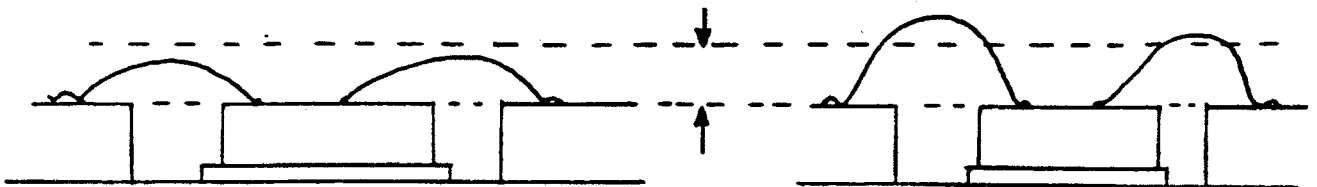
$a = 2$ when tape thickness $> 125\mu\text{m}$



FIGURE VI - WIRE OR TAPE TRAJECTORIES

TAPE: Max. 1.5mm or 30 tape thicknesses

WIRE: Max 500µm or 10 wire diameters

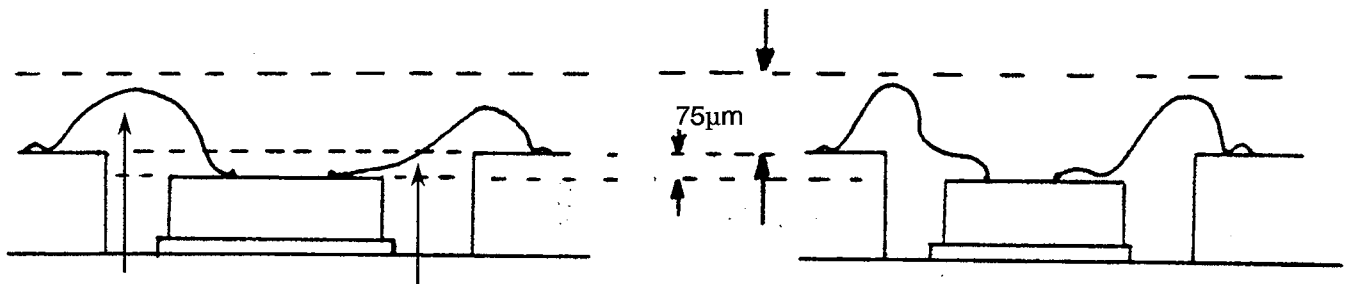


Accept
Both wires or tapes have proper trajectory

Reject
Wire or tape loops exceed permitted maximum clearance

TAPE: Max. 1.5mm or 30 tape thicknesses

WIRE: Max 500µm or 10 wire diameters



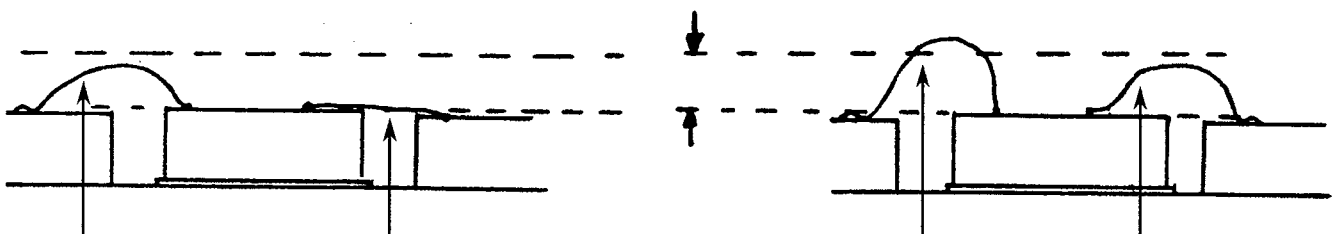
Accept

Reject
Wire or tape not clearing substrate by 75µm

Reject
Points of inflection not in vicinity of bends

TAPE: Max. 1.5mm or 30 tape thicknesses

WIRE: Max 500µm or 10 wire diameters



Accept

Reject
Insufficient arc

Reject
Wire or tape looped too high

Accept
Point of inflection in vicinity of bend



FIGURE VII - BALL BOND WIRE TRAJECTORY

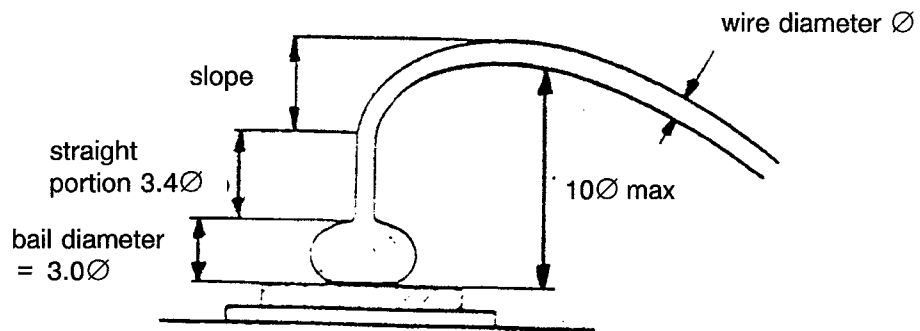
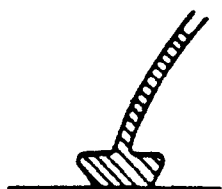
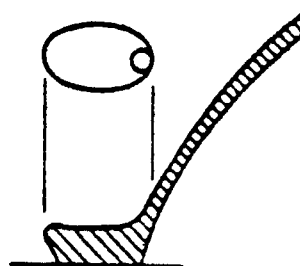




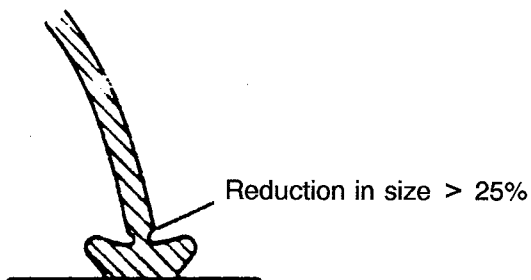
FIGURE VIII - BALL BONDS



Accept



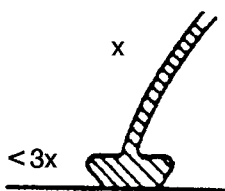
(c) Reject
Wire exits from edge of ball



(d) Reject



Accept



Too small

x

> 7x

Too large

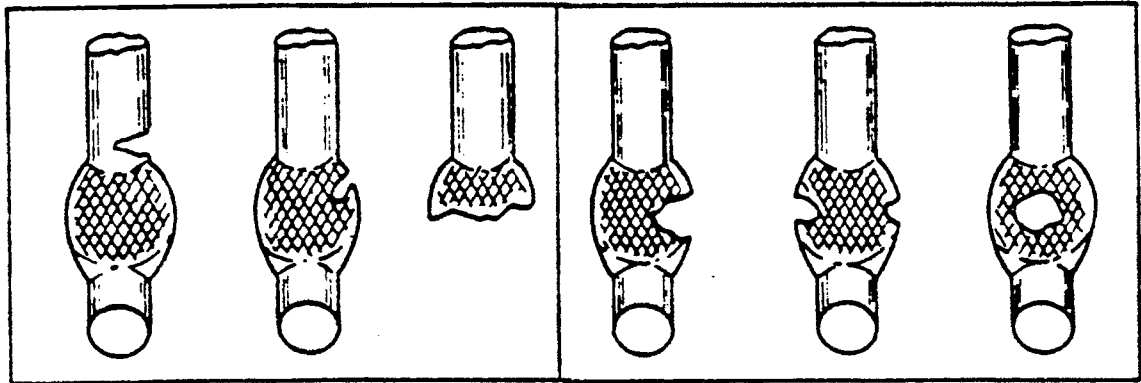
(e) Reject

NOTES

1. References (c), (d) and (e) relate to Para. 3.5.3.2.

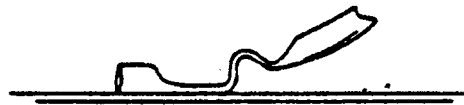


FIGURE IX - TORN AND INCOMPLETE BONDS



(a) Reject

(b) Reject



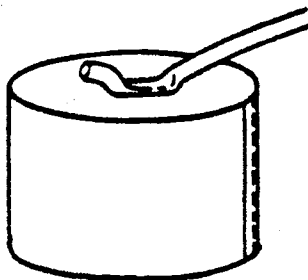
(c) Reject bond is > 25% lifted

NOTES

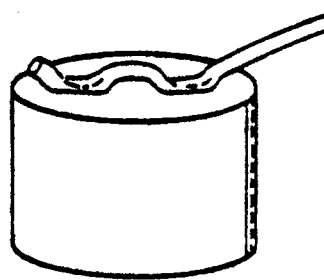
1. References (a), (b) and (c) relate to Para. 3.5.3.3.



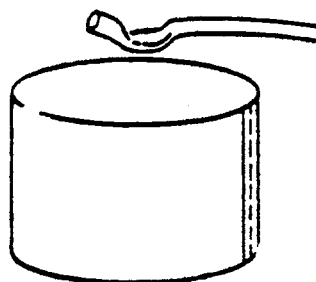
FIGURE X - LIFTED PIN BONDS



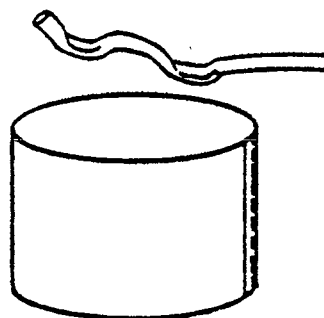
Accept



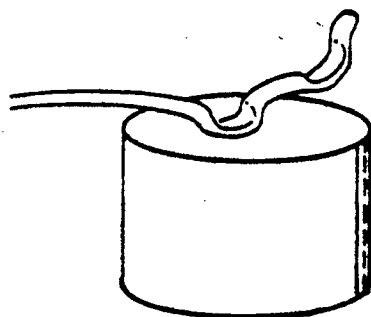
Accept



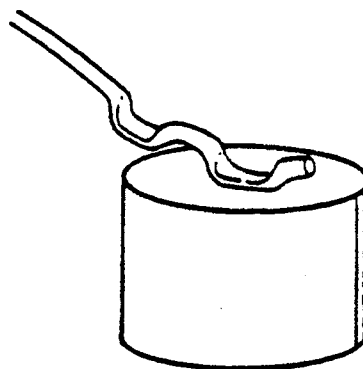
(d) Reject



(d) Reject



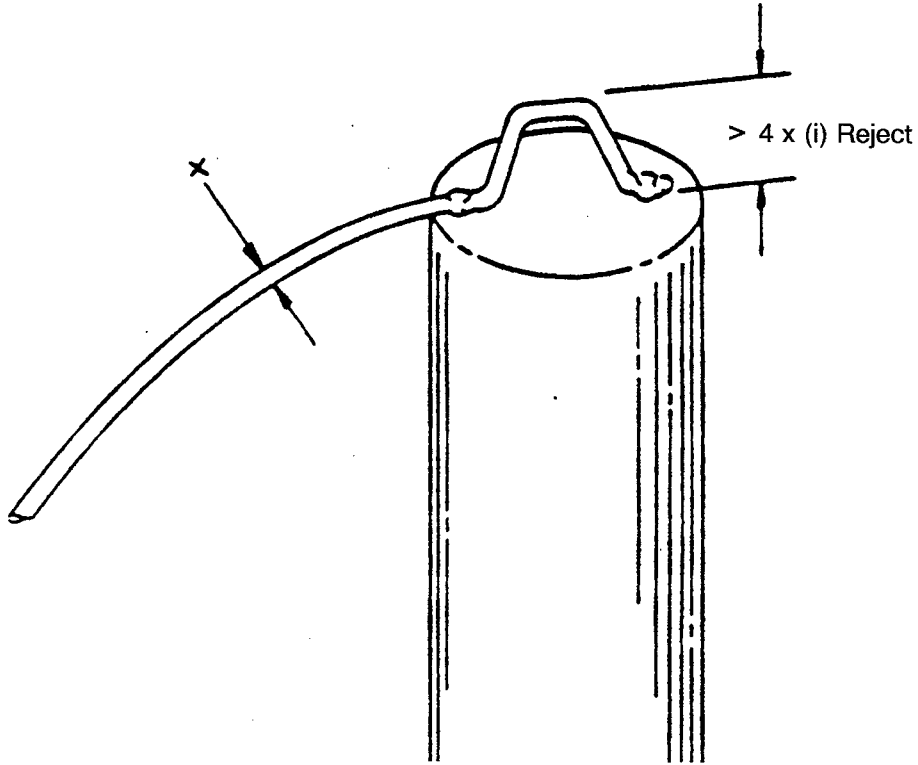
(d) Reject



(d) Reject



FIGURE XI - LOOP BETWEEN DOUBLE BOND



NOTES

1. See Para. 3.5.3.3.