



**CONTACTS, POWER, CRIMP-TYPE  
AND SOLDER TYPE FOR  
3401/001 AND 3401/002 CONNECTORS  
ESCC Detail Specification No. 3401/040**

**ISSUE 1  
October 2002**



	ESCC Detail Specification		PAGE ii ISSUE 1
---	---------------------------	--	--------------------

### **LEGAL DISCLAIMER AND COPYRIGHT**

European Space Agency, Copyright © 2002. All rights reserved.

The European Space Agency disclaims any liability or responsibility, to any person or entity, with respect to any loss or damage caused, or alleged to be caused, directly or indirectly by the use and application of this ESCC publication.

This publication, without the prior permission of the European Space Agency and provided that it is not used for a commercial purpose, may be:

- copied in whole in any medium without alteration or modification.
- copied in part, in any medium, provided that the ESCC document identification, comprising the ESCC symbol, document number and document issue, is removed.



europaean space agency  
agence spatiale européenne

Pages 1 to 16

**CONTACTS, POWER, CRIMP-TYPE  
AND SOLDER TYPE FOR  
3401/001 AND 3401/002 CONNECTORS  
ESA/SCC Detail Specification No. 3401/040**



**space components  
coordination group**

Issue/Rev.	Date	Approved by	
		SCCG Chairman	ESA Director General or his Deputy
Issue 1	November 1989		
Revision 'A'	May 1991		
Revision 'B'	July 2002		



**DOCUMENTATION CHANGE NOTICE**

Rev. Letter	Rev. Date	Reference	CHANGE Item	Approved DCR No.
'A'	May '91	P1. Cover page P2. DCN P5. Para. 1.1 P11. Para. 2	: References to ESA/SCC 3401/001 and 3401/002 amended : References to ESA/SCC 3401/001 and 3401/002 amended	None None 22785/ 23435 22785/ 23435
'B'	July '02	P1. Cover page P2. DCN P6 Table 1(a)	: Max. weight amended for all variants	None None 221680

**TABLE OF CONTENTS**

	<u>Page</u>
<b>1. <u>GENERAL</u></b>	<b>5</b>
1.1 Scope	5
1.2 Type Variants	5
1.3 Maximum Ratings	5
1.4 Parameter Derating Information	5
1.5 Physical Dimensions	5
1.6 Contact Arrangements	5
<b>2. <u>APPLICABLE DOCUMENTS</u></b>	<b>11</b>
<b>3. <u>TERMS, DEFINITIONS, ABBREVIATIONS, SYMBOLS AND UNITS</u></b>	<b>11</b>
<b>4. <u>REQUIREMENTS</u></b>	<b>11</b>
4.1 General	11
4.2 Deviations from Generic Specification	11
4.2.1 Deviations from Special In-process Controls	11
4.2.2 Deviations from Final Production Tests	11
4.2.3 Deviations from Burn-in and Electrical Measurements	11
4.2.4 Deviations from Qualification Tests	11
4.2.5 Deviations from Lot Acceptance Tests	11
4.3 Mechanical Requirements	12
4.3.1 Dimension Check	12
4.3.2 Weight	12
4.3.3 Crimp Tensile Strength or Pull Test	12
4.3.4 Gold Plate Thickness	12
4.3.5 Contact Insertion and Withdrawal Forces	12
4.3.6 Female Contact Capability	13
4.3.7 Oversized Pin Exclusion	13
4.3.8 Probe Damage	13
4.4 Materials and Finishes	13
4.4.1 Contact Body	13
4.5 Marking	13
4.5.1 General	13
4.5.2 The SCC Component Number	13
4.5.3 Traceability Information	14
4.6 Electrical Measurements	14
4.6.1 Electrical Measurements at Room Temperature	14
4.6.2 Electrical Measurements at High and Low Temperature	14
4.6.3 Circuits for Electrical Measurements	14
4.7 Screening Tests	14
4.8 Environmental and Endurance Tests	15
4.8.1 Measurements and Inspection on Completion of Environmental Tests	15
4.8.2 Measurements and Inspections at Intermediate Points during Endurance Tests	15
4.8.3 Measurements and Inspections on Completion of Endurance Tests	15
4.8.4 Conditions for Operating Life Test	15
4.8.5 Electrical Circuits for Operating Life Test	15
4.8.6 Conditions for High Temperature Storage Test	15



Page

**TABLES**

1(a)	Type Variants	6
1(b)	Maximum Ratings	6
2	Electrical Measurements at Room Temperature	15
3	Not applicable	
4	Not applicable	
5	Not applicable	
6	Measurements and Inspections on Completion of Environmental and Endurance Tests	16

**FIGURES**

1	Parameter Derating Information	7
2	Physical Dimensions	8
3	Contact Arrangements	N.A.

**APPENDICES (Applicable to specific Manufacturers only)**

None.

**1. GENERAL****1.1 SCOPE**

This specification details the ratings, physical and electrical characteristics, test and inspection data for Contacts, Power, Crimp-type and Solder-type, for 3401/001 and 3401/002 Connectors.

It shall be read in conjunction with:

- ESA/SCC Generic Specification No. 3401, Connectors, Electrical, Circular and Rectangular.
- ESA/SCC Detail Specification No. 3401/001, Connectors, Electrical, Rectangular, Miniature, Non-removable Solder and Wire-wrap Type Contacts and Removable Coaxial and Power, Crimp-type and Solder-type Contacts, Based on Type D\*M.
- ESA/SCC Detail Specification No. 3401/002, Connectors, Electrical, Rectangular, Miniature, Removable Crimp-type Contacts and Removable Coaxial and Power Crimp-type and Solder-type Contacts, Based on Type D\*MA.

the requirements of which are supplemented herein.

These contacts are not mounted in the connectors and are therefore delivered separately.

**1.2 TYPE VARIANTS**

Variants of the basic type contacts specified herein, which are also covered by this specification, together with their mechanical characteristics, are given in Table 1(a).

**1.3 MAXIMUM RATINGS**

The maximum ratings, which shall not be exceeded at any time during use or storage, applicable to the contacts specified herein, are scheduled in Table 1(b).

**1.4 PARAMETER DERATING INFORMATION**

The derating information applicable to the contacts specified herein is shown in Figure 1.

**1.5 PHYSICAL DIMENSION**

The physical dimensions of the contacts specified herein are shown in Figure 2.

**1.6 CONTACT ARRANGEMENTS**

Not applicable.

**TABLE 1(a) - TYPE VARIANTS**

Variant	Type	Max. Weight (gr)	Accepted Cable (AWG)	Bucket Type
01	Male	2.2	8	Solder
02	Female	1.9	8	Solder
03	Male	2.15	12	Solder
04	Female	1.9	12	Solder
05	Male	2.05	16	Solder
06	Female	1.75	16	Solder
07	Male	2.8	8	Crimp
08	Female	2.45	8	Crimp
09	Male	2.25	10	Crimp
10	Female	2.0	10	Crimp
11	Male	2.0	12 - 14	Crimp
12	Female	1.65	12 - 14	Crimp

**TABLE 1(b) - MAXIMUM RATINGS**

No.	Characteristic	Symbol	Maximum Rating	Unit	Remarks
1	Rated Current	$I_{CR}$	40	A	Note 1 Note 2
2	Operating Temperature Range	$T_{op}$	-55 to +125	°C	$T_{amb}$
3	Storage Temperature Range	$T_{stg}$	-55 to +125	°C	
4	Soldering Temperature	$T_{sol}$	+260	°C	Note 3

**NOTES**

1. This is limited either by the current carrying capability of the cable to which the contact is fitted or the derating.
2. At  $T_{amb} \leq +60^{\circ}C$ . For derating at  $T_{amb} > +60^{\circ}C$ , see Figure 1.
3. 10 seconds maximum.



**FIGURE 1 - PARAMETER DERATING INFORMATION**

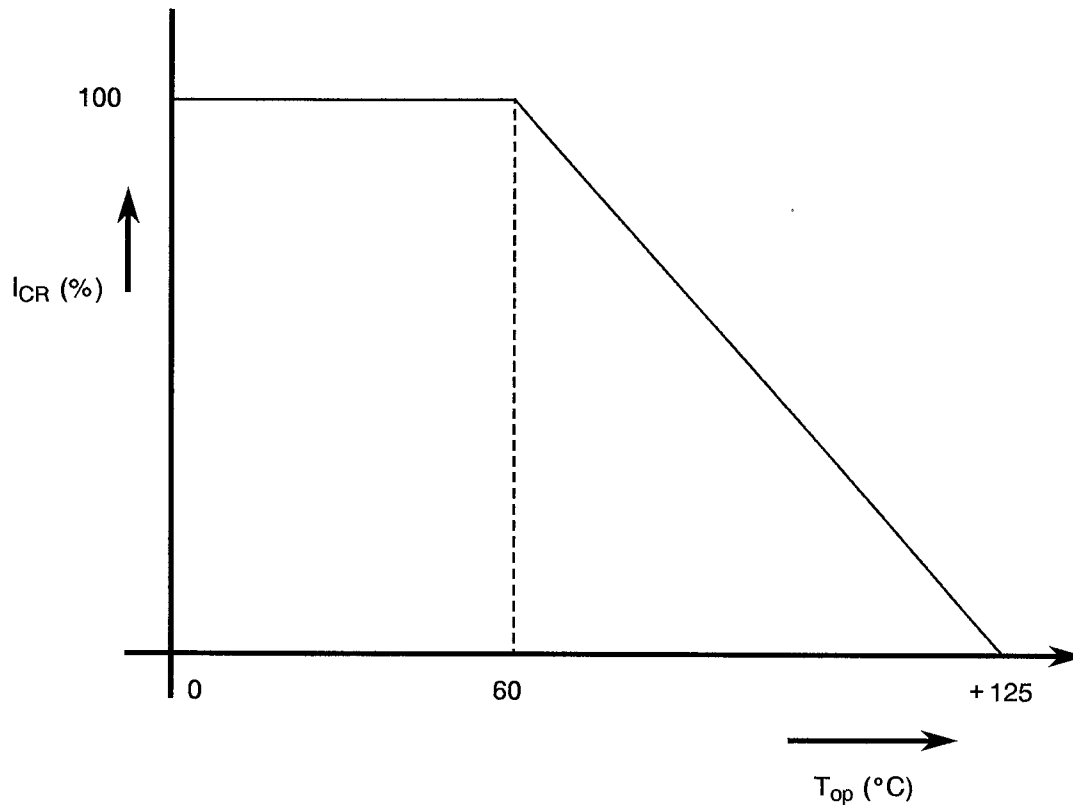

Rated Contact Current versus Temperature



**FIGURE 2 - PHYSICAL DIMENSIONS**

FIGURE 2(a) - SOLDER TYPE

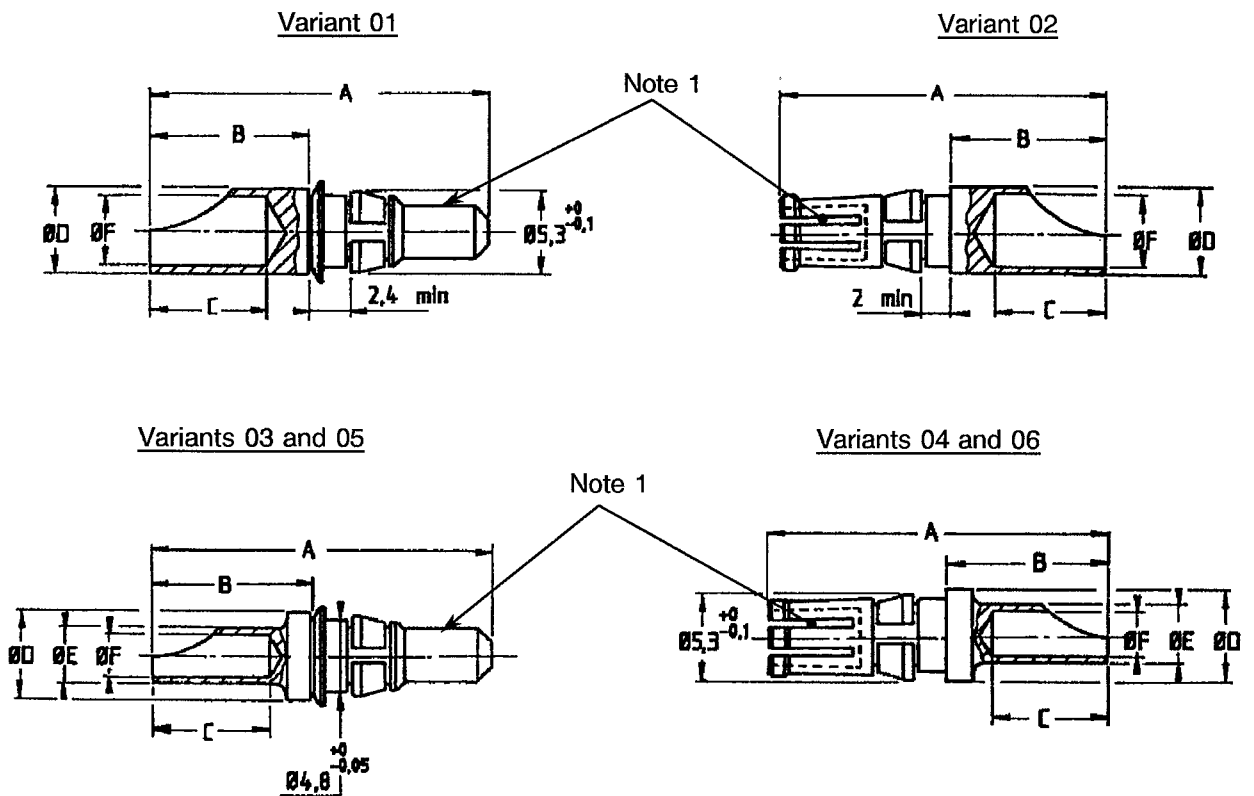

Variant (Note 2)	Type	AWG	A Max.	B Max.	C Max.	$\varnothing D$ Max.	$\varnothing E$ Max.	$\varnothing F$ Max.
01	Male	8	22.1	10.8	8.13	5.66	-	4.90
02	Female	8	21.8	10.8	8.13	5.66	-	4.90
03	Male	12	22.1	10.8	8.13	5.66	3.76	3.00
04	Female	12	21.8	10.8	8.13	5.66	3.76	3.00
05	Male	16	22.1	10.8	8.13	5.66	2.67	1.90
06	Female	16	21.8	10.8	8.13	5.66	2.67	1.90

**NOTES**

1. Measurement point for gold-plating thickness.
2. All dimensions are in millimetres.



**FIGURE 2 - PHYSICAL DIMENSIONS (Continued)**

**FIGURE 2(b) - CRIMP TYPE**

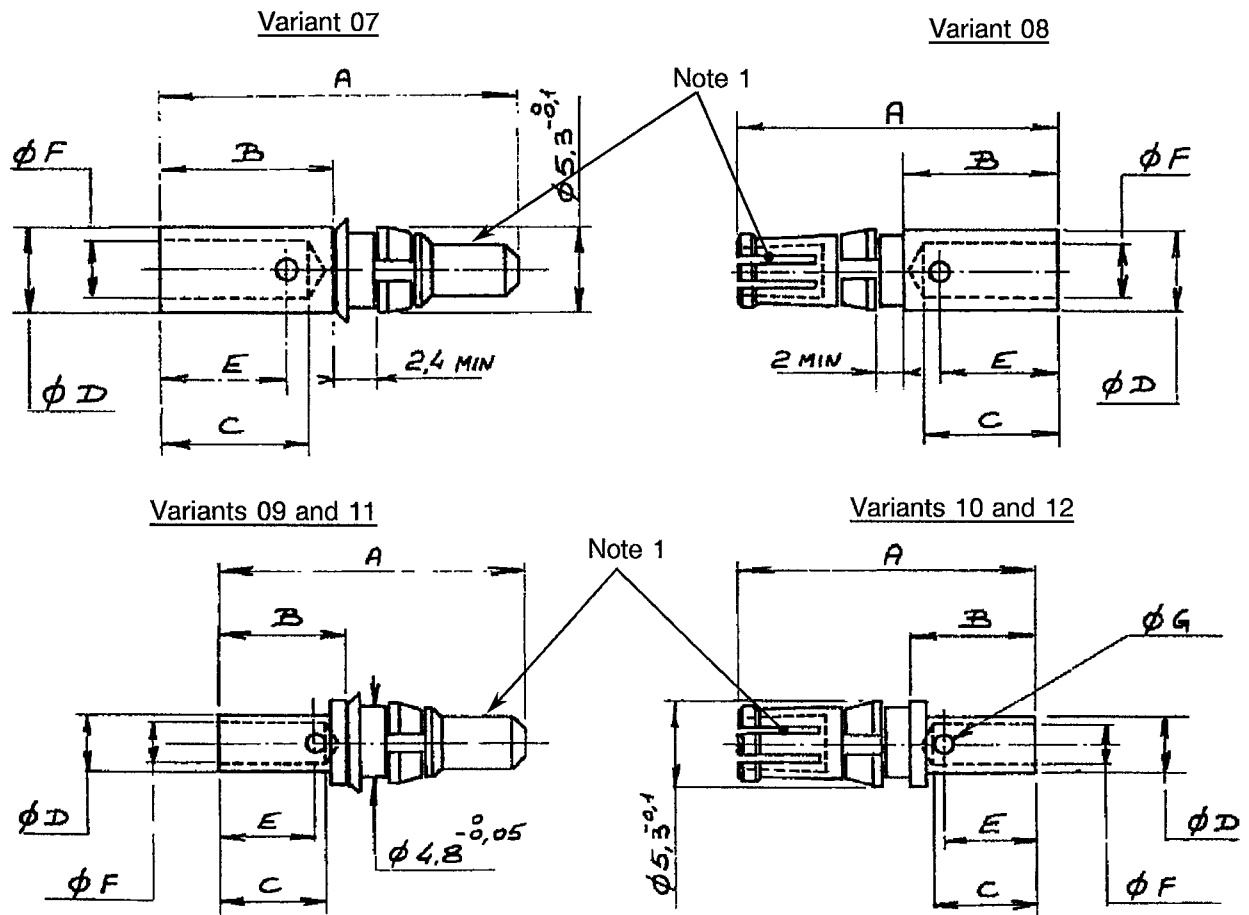

Variant (Note 2)	Type	AWG	A Max.	B Max.	C Min.	ØD Max.	E Ref.	ØF Min.	ØG Ref.
07	Male	8	24.7	12.9	11.1	5.8	10	4.2	1.7
08	Female	8	24.6	12.9	11.1	5.8	10	4.2	1.7
09	Male	10	21.6	10	8.4	4.7	7.5	3.25	1.3
10	Female	10	21.5	10	8.4	4.7	7.5	3.25	1.3
11	Male	12/14	19.3	7.7	6.35	3.8	6	2.5	1
12	Female	12/14	19.2	7.7	6.35	3.8	6	2.5	1

**NOTES**

1. Measurement point for gold-plating thickness.
2. All dimensions are in millimetres.

**FIGURE 2 - PHYSICAL DIMENSIONS (Continued)**

**FIGURE 2(c) - PROTRUSION AND RECESS**

**MAXIMUM PROTRUSION OF CONTACTS RELATIVE TO REAR OF SHELL FLANGE**

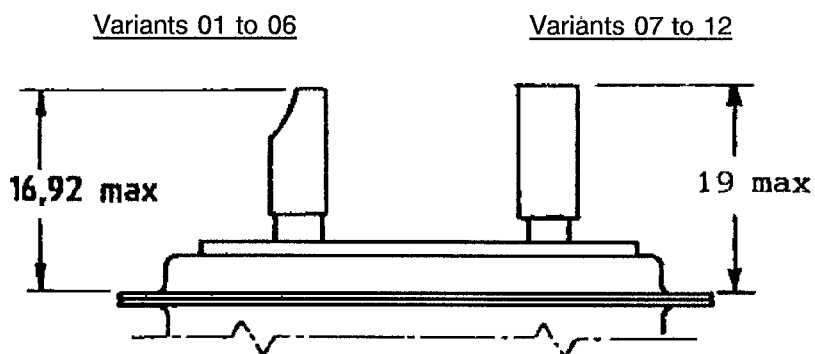

**MAXIMUM RECESS OF CONTACTS RELATIVE TO FRONT OF SHELL**

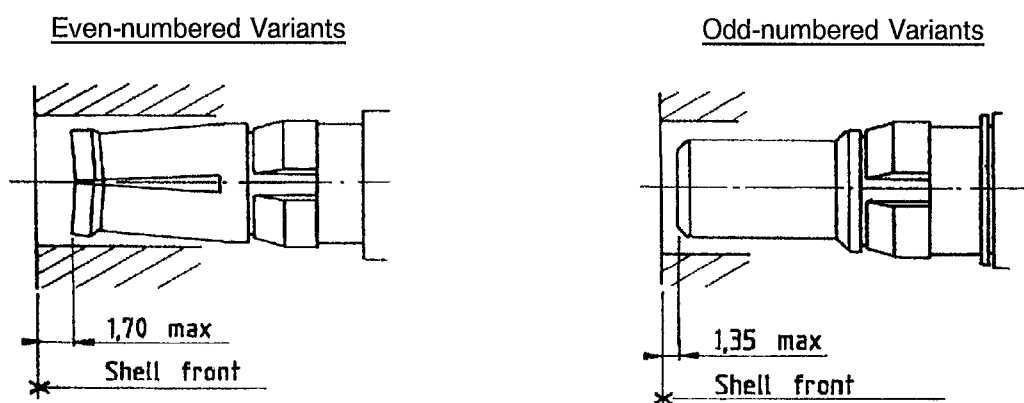

**NOTES**

1. All dimensions are in millimetres.

**2. APPLICABLE DOCUMENTS**

The following documents form part of this Specification and shall be read in conjunction with it:-

- (a) ESA/SCC Generic Specification No. 3401, Connectors, Electrical, Circular and Rectangular.
- (b) ESA/SCC Detail Specification No. 3401/001, Connectors, Electrical, Rectangular, Miniature, Non-removable Solder and Wire-wrap-type Contacts and Removable Coaxial and Power, Crimp-type and Solder-type Contacts, Based on Type D\*M.
- (c) ESA/SCC Detail Specification No. 3401/002, Connectors, Electrical, Miniature, Removable Crimp-type Contacts and Removable Coaxial and Power Crimp-type and Solder-type Contacts, based on Type D\*MA.
- (d) ESA/SCC Basic Specification No. 20534, External Visual Inspection of Electrical Connectors.
- (e) MIL-C-14550, Copper Plating, Electro-deposited.
- (f) MIL-G- 45204, Gold Plating, Electro-deposited.

**3. TERMS, DEFINITIONS, ABBREVIATIONS, SYMBOLS AND UNITS**

For the purpose of this specification, the terms, definitions, abbreviations, symbols and units specified in ESA/SCC Basic Specification No. 21300 shall apply.

**4. REQUIREMENTS****4.1 GENERAL**

The complete requirements for procurement of the contacts specified herein are stated in this specification and ESA/SCC Generic Specification No. 3401 for Connectors, Electrical, Circular and Rectangular. Deviations from the Generic Specification, applicable to this Detail Specification only, are listed in Para. 4.2. Deviations from the applicable Generic Specification and this Detail Specification, formally agreed with specific Manufacturers on the basis that the alternative requirements are equivalent to the ESA/SCC requirements and do not affect the components' reliability, are listed in the Appendices attached to this specification.

**4.2 DEVIATIONS FROM GENERIC SPECIFICATION****4.2.1 Deviations from Special In-process Controls**

None.

**4.2.2 Deviations from Final Production Tests (Chart II)**

None.

**4.2.3 Deviations from Burn-in and Electrical Measurements (Chart III)**

None.

**4.2.4 Deviations from Qualification Tests (Chart IV)**

- (a) Para. 9.21, Oversize Pin Exclusion: Not applicable.
- (b) Para. 9.24, Probe Damage Test: Not applicable.
- (c) Para. 9.27, Solderability: Bit size 7.5mm.
- (d) Para. 9.29, Pull Test: The direction of pull shall be in the contact axis.

**4.2.5 Deviations from Lot Acceptance Tests (Chart V)**

The deviations as listed in Para. 4.2.4 shall apply.



4.3 MECHANICAL REQUIREMENTS

4.3.1 Dimension Check

The dimensions of the contacts specified herein shall be verified in accordance with the requirements set out in Para. 9.11 of ESA/SCC Generic Specification No. 3401 and shall conform to those shown in Figure 2.

4.3.2 Weight

The maximum weight of the contacts specified herein shall be as specified in Table 1(a).

4.3.3 Crimp Tensile Strength or Pull Test

4.3.3.1 Crimp Tensile Strength (Variants 07 to 12)

The contacts shall be crimped to stranded wire of the appropriate size as shown below. The contact and the wire shall be separated from each other, using a tensile strength machine. The values of the force at separation of the contact and wire and the method of failure shall be recorded and shall be in accordance with the following values:

Variant	Wire Size (AWG)	Minimum Value of Tensile Strength (daN)
07/08	8	> 50
09/10	10	> 50
11/12	12 - 14	> 30

i.e. "pull-out", "break in crimp", "break in wire".

4.3.3.2 Pull Test (Variants 01 to 06)

The contacts shall be soldered to stranded wire of the appropriate size shown in Table 1(a) of this specification. The wire shall break before the solder. If the solder breaks before the wire, examine the solder pot for incomplete covering.

4.3.4 Gold Plate Thickness

The thickness of the gold plate deposited on the contacts specified herein shall be checked and meet the requirements of Subpara. 4.4.1. Measurements shall be performed on active parts as specified in Figure 2.

4.3.5 Contact Insertion and Withdrawal Forces (Variants 02, 04, 06, 08, 10, 12)

The contact insertion and withdrawal forces of the female contacts shall be as specified hereunder.

	Maximum Diameter Test Pin 3.532( + 0-0.0025) mm	Minimum Diameter Test Pin 3.581( + 0.0025-0) mm
Insertion	700gr	85gr
Withdrawal	567gr	85gr

**4.3.6 Female Contact Capability (Variants 02, 04, 06, 08, 10, 12)**

For the purposes of this test, the pick-up and drop weights shall be as follows.

	Pick-up Weight	Drop Weight
Weight	567gr	85gr
Pin Diameter	3.63mm	3.58mm
Insertion Depth	3.17mm	3.17mm

**4.3.7 Oversize Pin Exclusion**

Not applicable.

**4.3.8 Probe Damage Test**

Not applicable.

**4.4 MATERIAL AND FINISHES**

The materials and finishes shall be as specified herein. Where a definite material is not specified, a material which will enable the contacts specified herein to meet the performance requirements of this specification shall be used. Acceptance or approval of any constituent material does not guarantee acceptance of the finished product.

**4.4.1 Contact Body**

The contacts shall be made of copper base alloy selected from raw materials with a minimum of impurities. The contacts shall be plated as specified in MIL-G-45204, Type II, Grade 'C', gold over copper in accordance with MIL-C-14550. Gold plating thickness shall be 1.27 $\mu$ m minimum over 1 $\mu$ m minimum of copper.

**4.5 MARKING****4.5.1 General**

The marking of all components delivered to this specification shall be in accordance with the requirements of ESA/SCC Basic Specification No. 21700 and the following subparagraphs. These components being the too small to accommodate the marking as specified hereafter, the marking requirements in full shall accompany each lot of components in its primary package. Such marking shall comprise:-

- (a) The SCC Component Number.
- (b) Traceability Information.
- (c) Quantity of Components.

**4.5.2 The SCC Component Number**

Each component shall bear the SCC Component Number which shall be constituted and marked as follows:-

340104001B

Detail Specification Number \_\_\_\_\_

Type Variant (see Table 1(a)) \_\_\_\_\_

Testing Level \_\_\_\_\_

**4.5.3 Traceability Information**

Traceability information shall be marked in accordance with the requirements of ESA/SCC Basic Specification No. 21700.

**4.6 ELECTRICAL MEASUREMENTS****4.6.1 Electrical Measurements at Room Temperature**

The parameters to be measured in respect of electrical characteristics are scheduled in Table 2. Unless otherwise specified these measurements shall be performed at  $T_{amb} = +22 \pm 3 \text{ }^\circ\text{C}$ .

**4.6.2 Electrical Measurements at High and Low Temperatures (Table 3)**

Not applicable.

**4.6.3 Circuits for Electrical Measurements (Figure 4)**

Not applicable.

**4.7 Screening Tests (Tables 4 and 5)**

Not applicable.



**TABLE 2 - ELECTRICAL MEASUREMENTS AT ROOM TEMPERATURE**

No.	Characteristics	Symbol	ESA/SCC Gen. Spec. 3401	Test Condition	Limits		Unit
					Min.	Max.	
1	Contact Resistance (Low Level Current)	$R_C$	Para. 9.28	Para. 9.28.2	2.5	-	m $\Omega$
2	Contact Resistance (Rated current)	$R_C$	Para. 9.28	Para. 9.28.2	7	-	m $\Omega$

**TABLES 3, 4 AND 5**

Not applicable.

**4.8 ENVIRONMENTAL AND ENDURANCE TESTS****4.8.1 Measurements and Inspections on Completion of Environmental Tests**

The parameters to be measured and inspections to be performed on completion of environmental testing shall be those specified in Table 6. Unless otherwise specified, these measurements shall be performed at  $T_{amb} = +22 \pm 3$  °C.

**4.8.2 Measurements and Inspections at Intermediate Points during Endurance Tests**

Not applicable.

**4.8.3 Measurement and Inspections on Completion of Endurance Tests**

The parameters to be measured and inspections to be performed on completion of endurance testing shall be those specified in Table 6. Unless otherwise specified, these measurements shall be performed at  $T_{amb} = +22 \pm 3$  °C.

**4.8.4 Conditions for Operating Life Test (Part of Endurance Testing)**

Not applicable.

**4.8.5 Electrical Circuits for Operating Life Test**

Not applicable.

**4.8.6 Conditions for High Temperature Storage Test (Part of Endurance Testing)**

The requirements for the high temperature storage test are specified in Section 9 of ESA/SCC Generic Specification No. 3401. The temperature to be applied shall be the maximum storage temperature specified in Table 1(b) of this specification.



**TABLE 6 - MEASUREMENTS AND INSPECTIONS ON COMPLETION OF ENVIRONMENTAL AND ENDURANCE TESTS**

No.	ESA/SCC Gen. Spec. No. 3401		Measurements and Inspections		Symbol	Limits		Unit
	Environmental and Endurance Tests (1)	Test Method and Conditions	Identification	Conditions		Min.	Max.	
01	Female Contact Capability	Para. 9.6	Pick Up Weight Drop Weight	Para. 4.3.6 Para. 4.3.6		Pick Up Drop		
02	Oversize Pin Exclusion	Para. 9.21	Not applicable	-		-	-	
03	Gold Plate Thickness	Para. 9.22	Gold Plate Thickness	Para. 4.3.4		Para. 4.3.4		
04	Gold Plate Porosity	Para. 9.23	Not applicable	-		-	-	
05	Probe Damage Test	Para. 9.24	Not applicable	-		-	-	
06	Contact Insertion and Withdrawal Forces	Para. 9.25	Forces	Para. 4.3.5		Para. 4.3.5		
07	Crimp Visual Inspection	Para. 9.26	Visual Examination	-		-	-	
08	Solderability	Para. 9.27 and Para. 4.2.4 of this Spec.	-	-		-	-	
09	Contact Resistance	Para. 9.28	Contact Resistance	Low Level Table 2 Item 1 Rated Level Table 2 Item 2	R <sub>C</sub> R <sub>C</sub>	Table 2 Item 1 Table 2 Item 2		
10	Crimp Tensile Strength	Para. 9.29	-	Para. 4.3.3.1		-	-	
11	Pull Test	Para. 9.29 and Para. 4.2.4 of this Spec.	-	Para. 4.3.3.2		-	-	
12	Endurance	Para. 9.15	Contact Resistance Drift	Low Level Table 2 Item 1	ΔR <sub>C</sub>	-	0.5	mΩ
			Contact Resistance	Low Level Table 2 Item 1	R <sub>C</sub>	-	2.5	mΩ
13	High Temperature Storage	Para. 9.19 + 125°C	Contact Resistance Drift	Low Level Table 2 Item 1	ΔR <sub>C</sub>	-	0.5	mΩ
			Contact Resistance	Low Level Table 2 Item 1	R <sub>C</sub>	-	2.5	mΩ

**NOTES** 1. The tests in this Table refer to either Chart IV or V and shall be used as applicable.