



**INTEGRATED CIRCUITS, SILICON MONOLITHIC,
CMOS LOW POWER MONOSTABLE/ASTABLE
MULTIVIBRATOR,
BASED ON TYPE 4047B
ESCC Detail Specification No. 9207/003**

**ISSUE 1
October 2002**



	ESCC Detail Specification		PAGE ii ISSUE 1
--	---------------------------	--	--------------------

LEGAL DISCLAIMER AND COPYRIGHT

European Space Agency, Copyright © 2002. All rights reserved.

The European Space Agency disclaims any liability or responsibility, to any person or entity, with respect to any loss or damage caused, or alleged to be caused, directly or indirectly by the use and application of this ESCC publication.

This publication, without the prior permission of the European Space Agency and provided that it is not used for a commercial purpose, may be:

- copied in whole in any medium without alteration or modification.
- copied in part, in any medium, provided that the ESCC document identification, comprising the ESCC symbol, document number and document issue, is removed.



**european space agency
agence spatiale européenne**

Pages 1 to 46

**INTEGRATED CIRCUITS, SILICON MONOLITHIC,
CMOS LOW POWER MONOSTABLE/ASTABLE
MULTIVIBRATOR,
BASED ON TYPE 4047B
ESA/SCC Detail Specification No. 9207/003**



**space components
coordination group**

Issue/Rev.	Date	Approved by	
		SCCG Chairman	ESA Director General or his Deputy
Issue 3	July 2001		

**SCC**ESA/SCC Detail Specification
No. 9207/003

PAGE 2

ISSUE 3

DOCUMENTATION CHANGE NOTICE

Rev. Letter	Rev. Date	Reference	CHANGE Item	Approved DCR No.
		This Issue supersedes Issue 2 and incorporates all modifications defined in Revisions 'A', 'B' and 'C' to Issue 2 and the changes agreed in the following DCRs:- Cover page DCN Para. 1.3 : New sentence added Table 1(b) : No. 8, Maximum temperature amended Para. 4.8.6 : Last sentence deleted, new text added Appendix 'A' : Appendix added		None None 221602 221602 221602 221602

**ESC**ESA/SCC Detail Specification
No. 9207/003

PAGE 3

ISSUE 3

TABLE OF CONTENTS

	<u>Page</u>
1. <u>GENERAL</u>	5
1.1 Scope	5
1.2 Component Type Variants	5
1.3 Maximum Ratings	5
1.4 Parameter Derating Information	5
1.5 Physical Dimensions	5
1.6 Pin Assignment	5
1.7 Truth Table	5
1.8 Circuit Schematic	5
1.9 Functional Diagram	5
1.10 Handling Precautions	5
1.11 Input Protection Network	5
2. <u>APPLICABLE DOCUMENTS</u>	17
3. <u>TERMS, DEFINITIONS, ABBREVIATIONS, SYMBOLS AND UNITS</u>	17
4. <u>REQUIREMENTS</u>	17
4.1 General	
4.2 Deviations from Generic Specification	17
4.2.1 Deviations from Special In-process Controls	17
4.2.2 Deviations from Final Production Tests	17
4.2.3 Deviations from Burn-in Tests	17
4.2.4 Deviations from Qualification Tests	17
4.2.5 Deviations from Lot Acceptance Tests	18
4.3 Mechanical Requirements	18
4.3.1 Dimension Check	18
4.3.2 Weight	18
4.4 Materials and Finishes	18
4.4.1 Case	18
4.4.2 Lead Material and Finish	18
4.5 Marking	18
4.5.1 General	18
4.5.2 Lead Identification	18
4.5.3 The SCC Component Number	19
4.5.4 Traceability Information	19
4.6 Electrical Measurements	19
4.6.1 Electrical Measurements at Room Temperature	19
4.6.2 Electrical Measurements at High and Low Temperatures	19
4.6.3 Circuits for Electrical Measurements	19
4.7 Burn-in Tests	19
4.7.1 Parameter Drift Values	19
4.7.2 Conditions for H.T.R.B. and Burn-in	19
4.7.3 Electrical Circuits for H.T.R.B. and Burn-in	19
4.8 Environmental and Endurance Tests	44
4.8.1 Electrical Measurements on Completion of Environmental Tests	44
4.8.2 Electrical Measurements at Intermediate Points during Endurance Tests	44
4.8.3 Electrical Measurements on Completion of Endurance Tests	44
4.8.4 Conditions for Operating Life Test	44
4.8.5 Electrical Circuits for Operating Life Tests	44
4.8.6 Conditions for High Temperature Storage Test	44

**SCC**ESA/SCC Detail Specification
No. 9207/003

PAGE 4

ISSUE 3

TABLESPage

1(a)	Type Variants	6
1(b)	Maximum Ratings	6
2	Electrical Measurements at Room Temperature, d.c. Parameters	20
	Electrical Measurements at Room Temperature, a.c. Parameters	23
3(a)	Electrical Measurements at High Temperature	25
3(b)	Electrical Measurements at Low Temperature	28
4	Parameter Drift Values	39
5(a)	Conditions for Burn-in High Temperature Reverse Bias, N-Channels	40
5(b)	Conditions for Burn-in High Temperature Reverse Bias, P-Channels	40
5(c)	Conditions for Burn-in Dynamic	41
6	Electrical Measurements on Completion of Environmental Tests and at Intermediate Points and on Completion of Endurance Testing.	45

FIGURES

1	Not applicable	
2	Physical Dimensions	7
3(a)	Pin Assignment	12
3(b)	Truth Table	13
3(c)	Circuit Schematic	14
3(d)	Functional Diagram	15
3(e)	Input Protection Networks	16
4	Circuits for Electrical Measurements	31
5(a)	Electrical Circuit for Burn-in High Temperature Reverse Bias, N-Channels	42
5(b)	Electrical Circuit for Burn-in High Temperature Reverse Bias, P-Channels	42
5(c)	Electrical Circuit for Burn-in Dynamic	43

APPENDICES (Applicable to specific Manufacturers only)

'A'	Agreed Deviations for STMicroelectronics (F)	46
-----	--	----

**1. GENERAL****1.1 SCOPE**

This specification details the ratings, physical and electrical characteristics, test and inspection data for a silicon monolithic, CMOS Low Power Monostable/Astable Multivibrator, having fully buffered outputs, based on Type 4047B. It shall be read in conjunction with ESA/SCC Generic Specification No. 9000, the requirements of which are supplemented herein.

1.2 COMPONENT TYPE VARIANTS

Variants of the basic type integrated circuits specified herein, which are also covered by this specification, are given in Table 1(a).

1.3 MAXIMUM RATINGS

The maximum ratings, which shall not be exceeded at any time during use or storage, applicable to the integrated circuits specified herein, are as scheduled in Table 1(b).

Maximum ratings shall only be exceeded during testing to the extent specified in this specification and when stipulated in Test Methods and Procedures of the applicable ESA/SCC Generic Specification.

1.4 PARAMETER DERATING INFORMATION (FIGURE 1)

Not applicable.

1.5 PHYSICAL DIMENSIONS

As per Figure 2.

1.6 PIN ASSIGNMENT

As per Figure 3(a).

1.7 TRUTH TABLE

As per Figure 3(b).

1.8 CIRCUIT SCHEMATIC

As per Figure 3(c).

1.9 FUNCTIONAL DIAGRAM

As per Figure 3(d).

1.10 HANDLING PRECAUTIONS

These devices are susceptible to damage by electrostatic discharge. Therefore, suitable precautions shall be employed for protection during all phases of manufacture, testing, packaging, shipment and any handling. These components are Catagorised as Class 1 with a Minimum Critical Path Failure Voltage of 400Volts.

1.11 INPUT PROTECTION NETWORKS

Double diode protection shall be incorporated into each input as shown in Figure 3(e).



TABLE 1(a) - TYPE VARIANTS

VARIANT	CASE	FIGURE	LEAD MATERIAL AND/OR FINISH
01	FLAT	2(a)	G2 or G8
02	FLAT	2(a)	G4
03	D.I.L.	2(b)	G2 or G8
04	D.I.L.	2(b)	G4
07	CHIP CARRIER	2(c)	2
08	SO CERAMIC	2(d)	G2
09	SO CERAMIC	2(d)	G4

TABLE 1(b) - MAXIMUM RATINGS

NO.	CHARACTERISTICS	SYMBOL	MAXIMUM RATINGS	UNIT	REMARKS
1	Supply Voltage	V_{DD}	-0.5 to +18	V	Note 1
2	Input Voltage	V_{IN}	-0.5 to $V_{DD} + 0.5$	V	Note 2 Power on
3	D.C. Input Current	$\pm I_{IN}$	10	mA	Note 3
4	D.C. Output Current	$\pm I_O$	10	mA	Note 4
5	Device Dissipation	P_D	200	mWdc	Per Package
6	Output Dissipation	P_{DSO}	100	mWdc	Note 5
7	Operating Temperature Range	T_{op}	-55 to +125	°C	-
8	Storage Temperature Range	T_{stg}	-65 to +150	°C	-
9	Soldering Temperature For FP and DIP For CCP	T_{sol}	+300 +245	°C	Note 6 Note 7

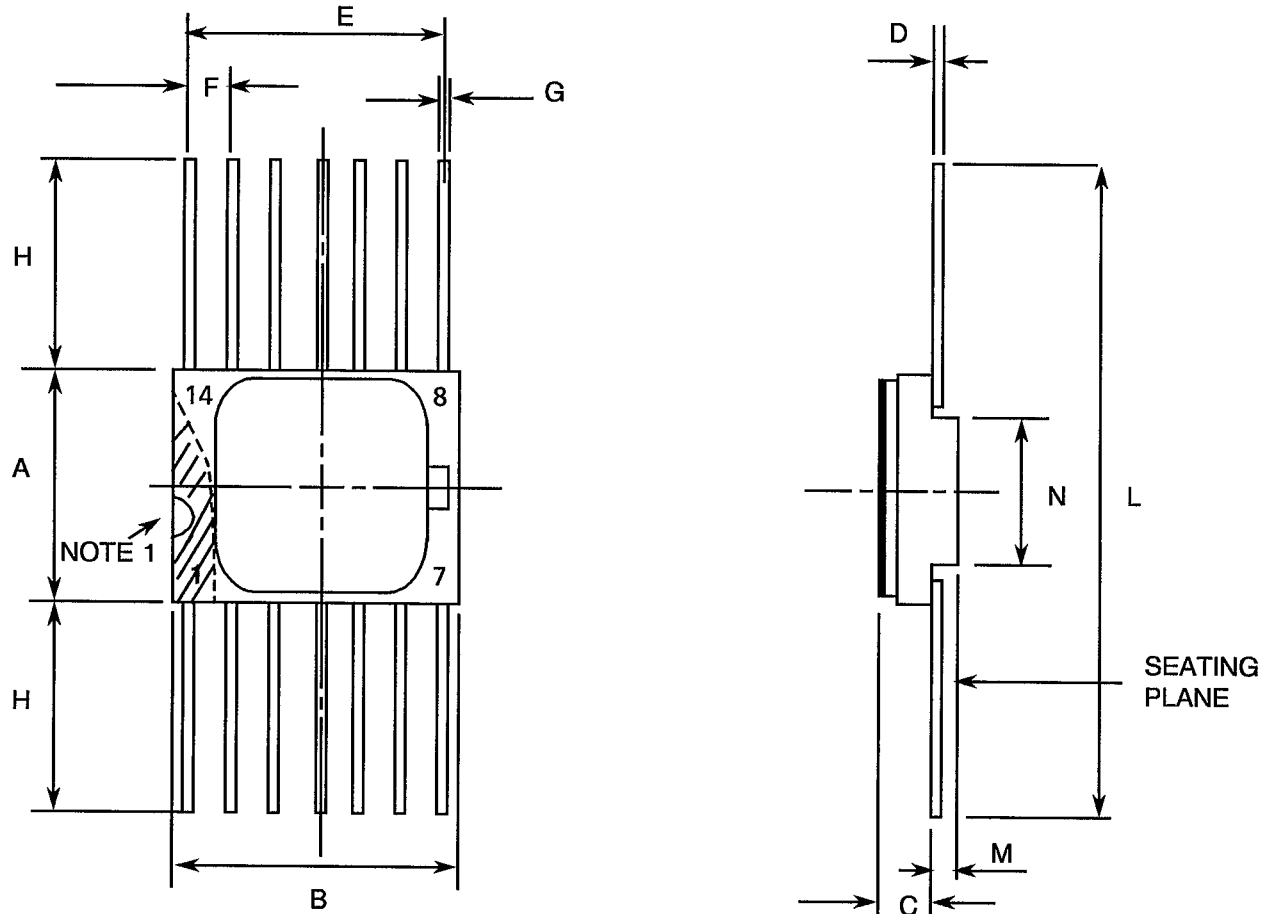
NOTES

- Device is functional from +3V to +15V with reference to V_{SS} .
- $V_{DD} + 0.5V$ should not exceed +18V.
- The maximum input current of any single input
- The maximum output current of any single output.
- The maximum power dissipation of any single output.
- Duration 10 seconds maximum at a distance of not less than 1.5mm from the device body and the same lead shall not be resoldered until 3 minutes have elapsed.
- Duration 30 seconds maximum and the same terminal shall not be resoldered until 3 minutes have elapsed.



FIGURE 2 - PHYSICAL DIMENSIONS

FIGURE 2(a) - FLAT PACKAGE, 14-Pin



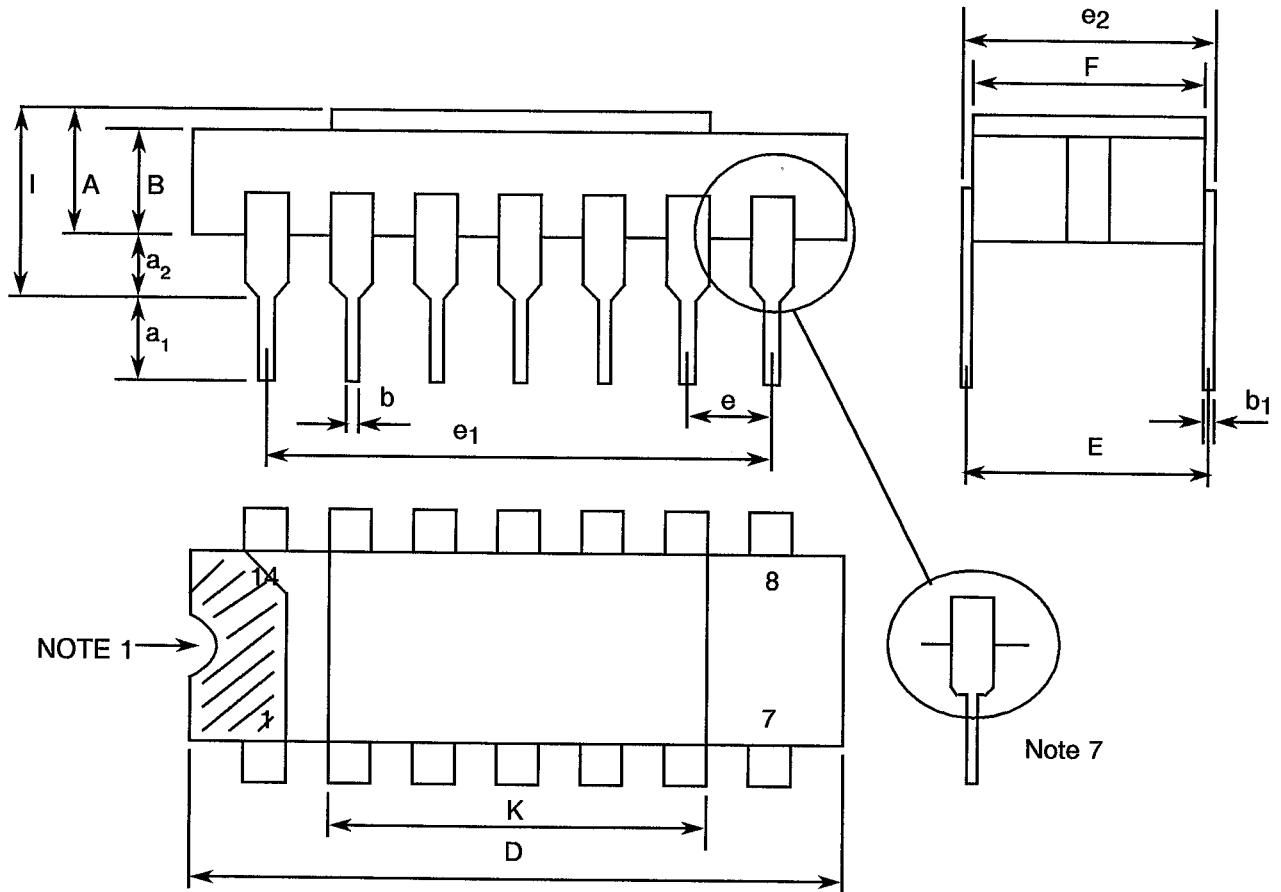
SYMBOL	MILLIMETRES		NOTES
	MIN	MAX	
A	6.75	7.06	
B	9.76	10.14	
C	1.49	1.95	
D	0.102	0.152	3
E	7.50	7.75	
F	1.27	TYPICAL	4
G	0.38	0.48	3
H	6.0	-	3
L	18.75	22.0	
M	0.33	0.43	
N	4.31	TYPICAL	

NOTES: See Page 11.



FIGURE 2 - PHYSICAL DIMENSIONS (CONTINUED)

FIGURE 2(b) - DUAL-IN-LINE PACKAGE, 14-PIN



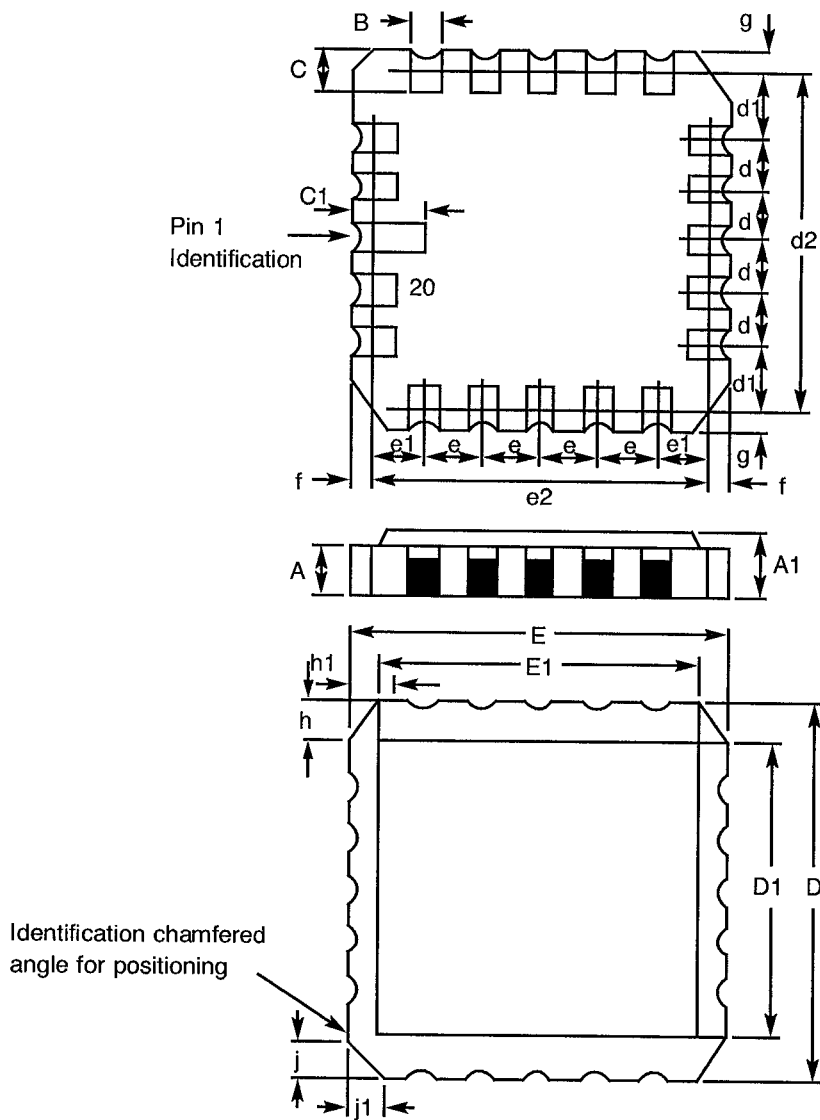
SYMBOL	MILLIMETRES		NOTES
	MIN	MAX	
A	2.10	2.54	
a ₁	3.0	3.7	
a ₂	0.63	1.14	2
B	1.82	2.23	
b	0.40	0.50	3
b ₁	0.20	0.30	3
D	18.79	19.20	
E	7.36	7.87	
e	2.29	2.79	4
e ₁	15.11	15.37	
e ₂	7.62	8.12	
F	7.11	7.75	
I	-	3.70	
K	10.90	12.10	

NOTES: See Page 11.



FIGURE 2 - PHYSICAL DIMENSIONS (CONTINUED)

FIGURE 2(c) - CHIP CARRIER - 20-TERMINAL



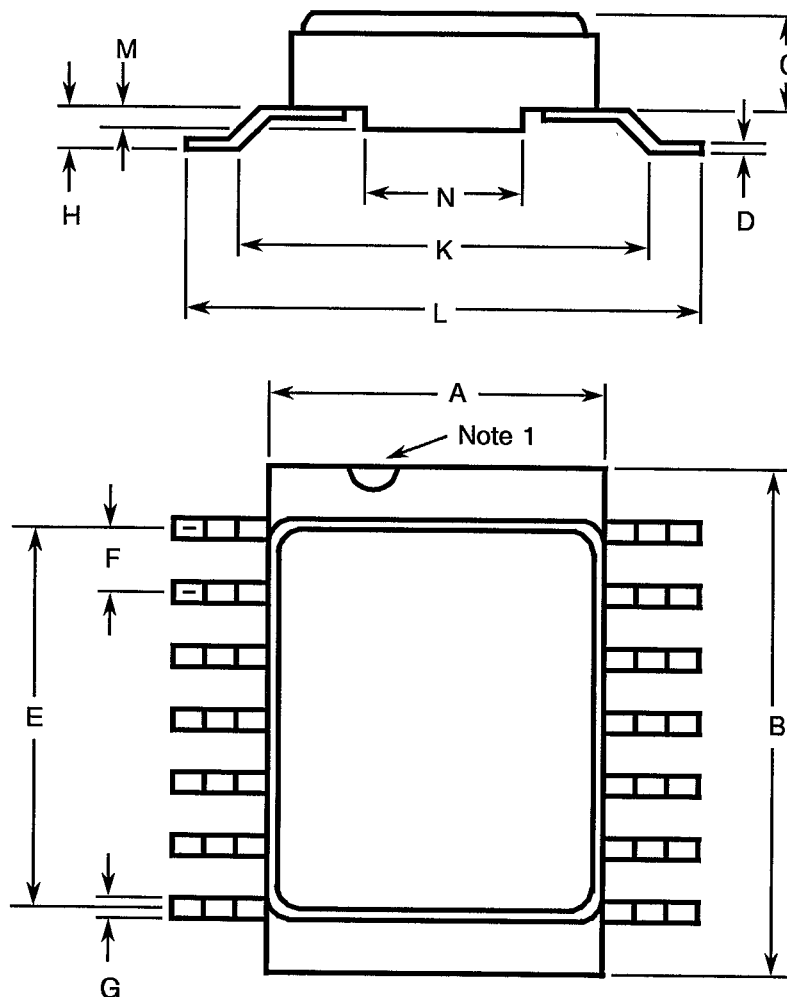
DIMENSIONS	MILLIMETRES		NOTES
	MIN	MAX	
A	1.14	1.95	
A1	1.63	2.36	
B	0.55	0.72	3
C	1.06	1.47	3
C ₁	1.91	2.41	
D	8.67	9.09	
D1	7.21	7.52	
d, d1	1.27	TYPICAL	4
d2	7.62	TYPICAL	
E	8.67	9.09	
E1	7.21	7.52	
e, e1	1.27	TYPICAL	4
e2	7.62	TYPICAL	
f, g	-	0.76	
h, h1	1.01	TYPICAL	6
j, j1	0.51	TYPICAL	5

NOTES: See Page 11.



FIGURE 2 - PHYSICAL DIMENSIONS (CONTINUED)

FIGURE 2(d) - SMALL OUTLINE CERAMIC PACKAGE, 14-PIN



SYMBOL	MILLIMETRES		NOTES
	MIN.	MAX.	
A	6.75	7.06	
B	9.76	10.14	
C	1.49	1.95	
D	0.102	0.152	3
E	7.50	7.75	
F	1.27 TYPICAL		4
G	0.38	0.48	3
H	0.60	0.90	3
K	9.00 TYPICAL		
L	10	10.65	
M	0.33	0.43	
N	4.31 TYPICAL		

NOTES: See Page 11.

**SCC**ESA/SCC Detail Specification
No. 9207/003

PAGE 11

ISSUE 3

FIGURE 2 - PHYSICAL DIMENSIONS (CONTINUED)**NOTES TO FIGURES 2(a) TO 2(d) INCLUSIVE**

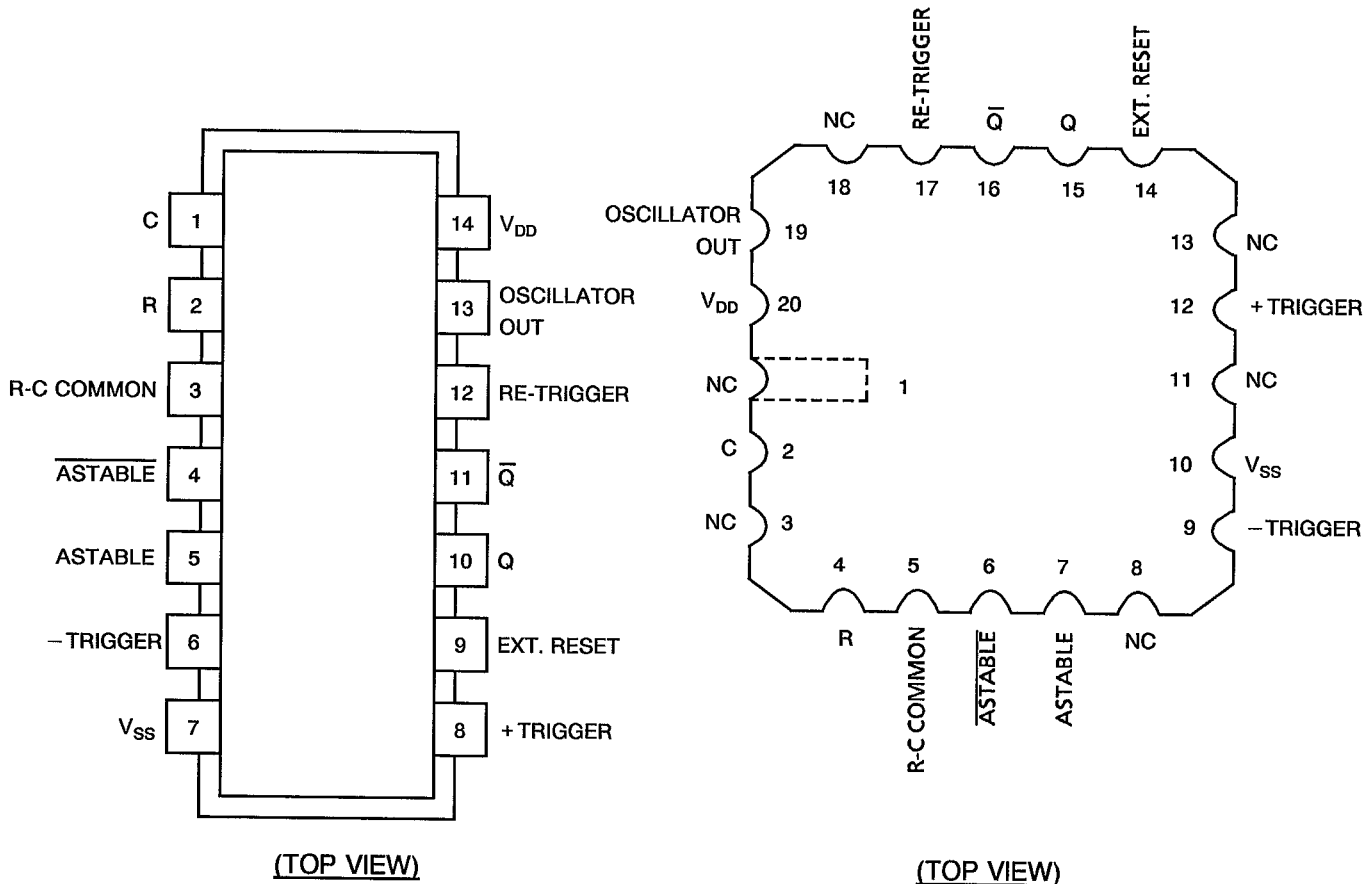
1. Index area: a notch, letter or dot shall be located adjacent to Pin 1 and shall be within the shaded area shown. For chip carrier packages the index shall be as defined in Figure 2(c).
2. The dimension shall be measured from the seating plane to the base plane.
3. All leads or terminals.
4. Twelve spaces.
5. Index corner only.
6. Three non-index corners.
7. For all pins, either pin shape may be supplied.



FIGURE 3(a) - PIN ASSIGNMENT

DUAL-IN-LINE, SO AND FLAT PACKAGES

CHIP CARRIER PACKAGE



FLAT PACKAGE, SO AND DUAL-IN-LINE TO CHIP CARRIER PIN ASSIGNMENT

FLAT PACKAGE, SO AND DUAL-IN-LINE PIN OUTS	1	2	3	4	5	6	7	8	9	10	11	12	13	14
CHIP CARRIER PIN OUTS	2	4	5	6	7	9	10	12	14	15	16	17	19	20



FIGURE 3(b) - TRUTH TABLE

(i) ASTABLE FUNCTION TABLE

FUNCTION						OUTPUT			NOTES
$\overline{\text{Astable}}$	Astable	-Trigger	+ Trigger	Ext. Reset	Retrigger	Q	\overline{Q}	Osc	
H	H	H	L	L	L				1,4
H		H	L	L	L				2,4
	L	H	L	L	L				3,4

(ii) MONOSTABLE FUNCTION TABLE

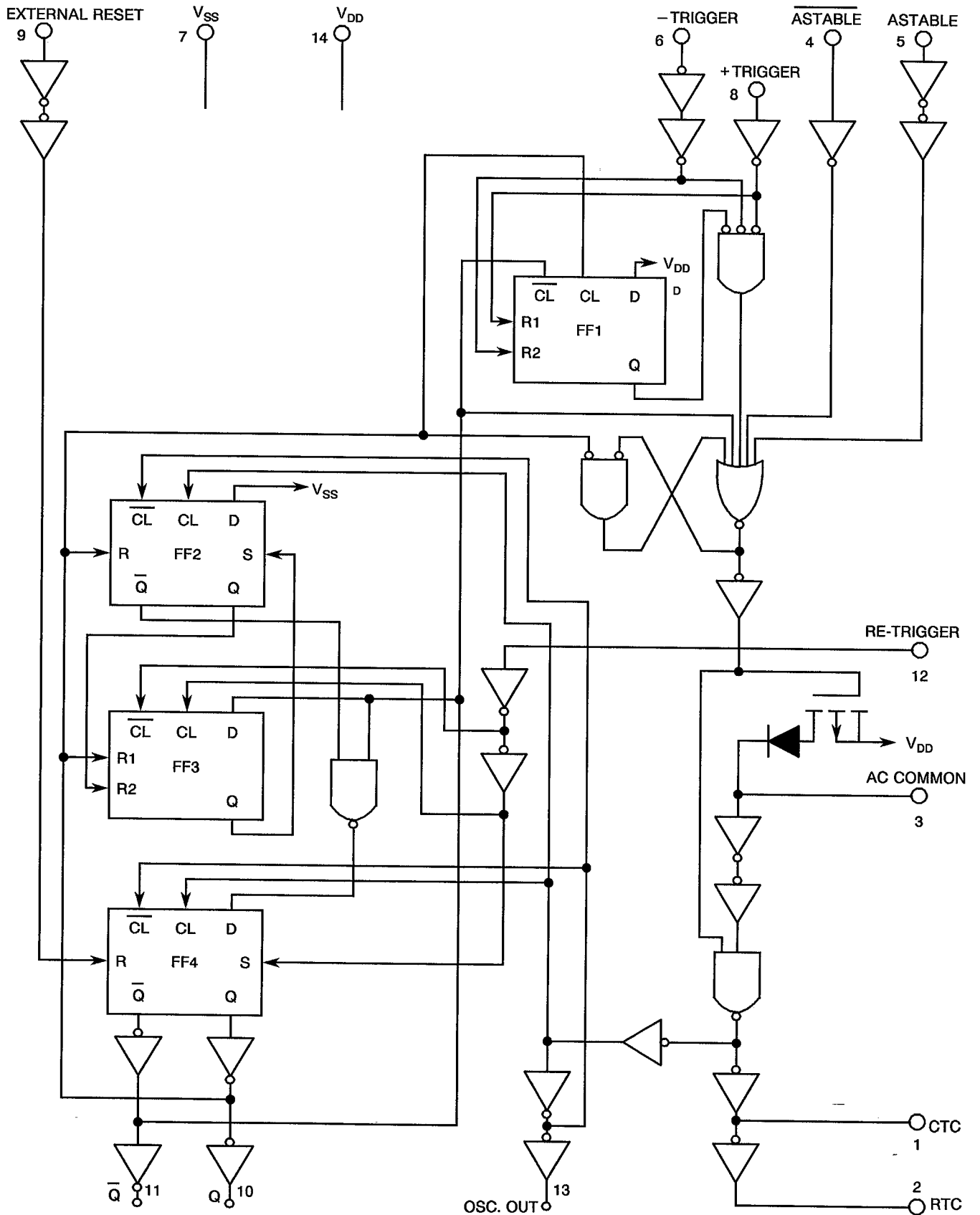
FUNCTION						OUTPUT			NOTES
$\overline{\text{Astable}}$	Astable	-Trigger	+ Trigger	Ext. Reset	Retrigger	Q	\overline{Q}	Osc	
H	L	L		L	L			-	5,8
H	L		H	L	L			-	6,8
H	L	L		L				-	7,8
X	X	X	X	H	X	L	H	-	9,10

NOTES

- Output is free running.
- True gating.
- Complementary gating.
- Output pulse width at Q and $\overline{Q} = t_A = 4.40 R_{EXT} C_{EXT}$.
Output pulse width at Osc = $t_A = 2.20 R_{EXT} C_{EXT}$.
- Positive edge trigger.
- Negative edge trigger.
- Re-trigger (positive edge only).
- Output pulse width at Q and $\overline{Q} = t_M = 2.48 R_{EXT} C_{EXT}$.
- External Reset during "ON" power condition.
- In the monostable mode, a high level or power-on reset pulse must be applied to External Reset whenever V_{DD} is applied.



FIGURE 3(c) - CIRCUIT SCHEMATIC



NOTES

- 1. Pin 3 is more sensitive to Static Electrical Discharge. Extra handling precautions are necessary.



FIGURE 3(d) - FUNCTIONAL DIAGRAM

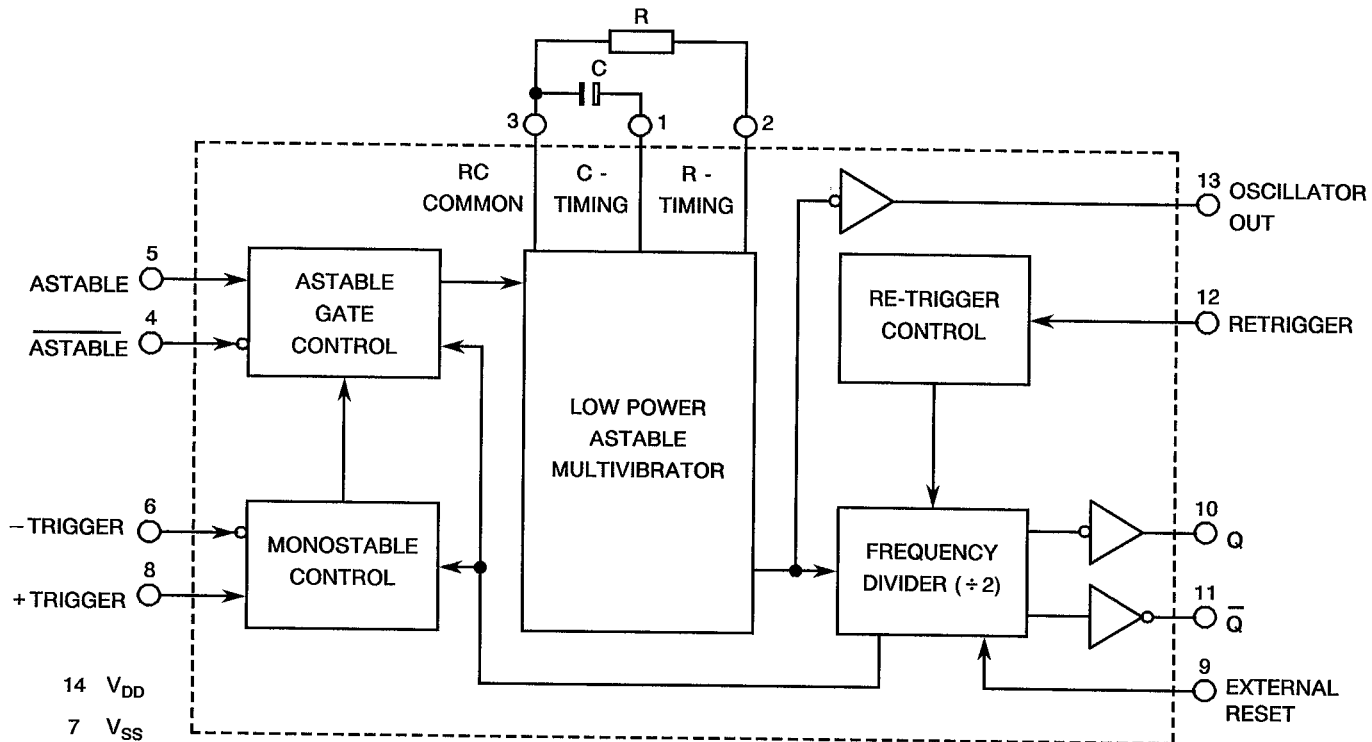
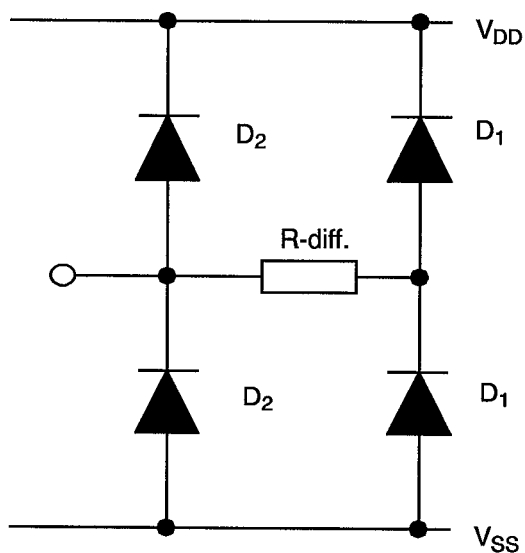


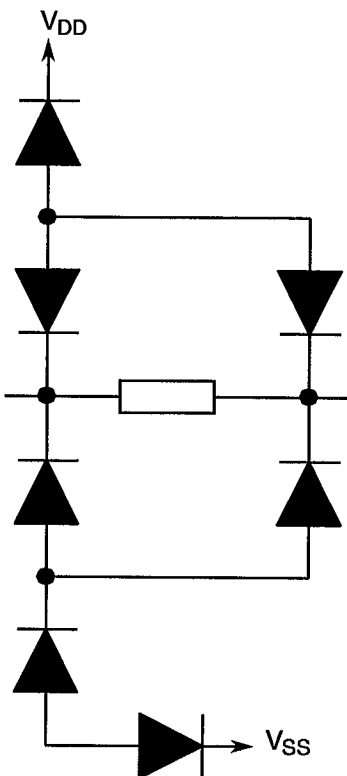


FIGURE 3(e) - INPUT PROTECTION NETWORK

CIRCUIT (i) - NORMAL INPUT PROTECTION NETWORK



CIRCUIT (ii) - SPECIAL RC COMMON INPUT PROTECTION NETWORK



**2. APPLICABLE DOCUMENTS**

The following documents form part of this specification and shall be read in conjunction with it:-

- (a) ESA/SCC Generic Specification No. 9000 for Integrated Circuits.
- (b) MIL-STD-883, Test Methods and Procedures for Micro-electronics.

3. TERMS, DEFINITIONS, ABBREVIATIONS, SYMBOLS AND UNITS

For the purpose of this specification, the terms, definitions, abbreviations, symbols and units specified in ESA/SCC Basic Specification No. 21300 shall apply. In addition, the following abbreviations are used:

- V_{IC} = Input Clamp Voltage.
- P_{DSO} = Single Output Power Dissipation.
- CKT = Circuit.

4. REQUIREMENTS**4.1 GENERAL**

The complete requirements for procurement of the integrated circuits specified herein shall be as stated in this specification and ESA/SCC Generic Specification No. 9000 for Integrated Circuits. Deviations from the Generic Specification, applicable to this specification only, are listed in Para. 4.2.

Deviations from the applicable Generic Specification and this Detail Specification, formally agreed with specific Manufacturers on the basis that the alternative requirements are equivalent to the ESA/SCC requirement and do not affect the components' reliability, are listed in the appendices attached to this specification.

4.2 DEVIATIONS FROM GENERIC SPECIFICATION**4.2.1 Deviations from Special In-process Controls**

None.

4.2.2 Deviations from Final Production Tests (Chart II)

None.

4.2.3 Deviations from Burn-in Tests (Chart III)**4.2.3.1 Deviations from High Temperature Reverse Bias (H.T.R.B.)**

Prior to operating power burn-in, a high temperature reverse bias (H.T.R.B.) screen at +125°C shall be added for the N-Channel and then for the P-Channel in accordance with Tables 5(a) and 5(b) of this specification. Each exposure to H.T.R.B. shall be 72 hours and Table 4 Parameter Drift Values shall be applied at 0 and 144 hours.

4.2.4 Deviations from Qualification Tests (Chart IV)

None.



4.2.5 Deviations from Lot Acceptance Tests (Chart V)

None.

4.3 MECHANICAL REQUIREMENTS

4.3.1 Dimension Check

The dimensions of the integrated circuits specified herein shall be checked. They shall conform to those shown in Figure 2.

4.3.2 Weight

The maximum weight of the integrated circuits specified herein shall be 1.34 grammes for the dual-in-line package, 0.58 grammes for the flat and SO packages and 0.52 grammes for the chip carrier package.

4.4 MATERIALS AND FINISHES

The materials and finishes shall be as specified herein. Where a definite material is not specified, a material which will enable the integrated circuits specified herein to meet the performance requirements of this specification shall be used. Acceptance or approval of any constituent material does not guarantee acceptance of the finished product.

4.4.1 Case

The case shall be hermetically sealed and have a metal body with hard glass seals or a ceramic body and the lids shall be welded, brazed or preform-soldered.

4.4.2 Lead Material and Finish

For dual-in-line and flat packages, the material shall be Type 'G' with either Type '4' or Type '2 or 8' finish in accordance with ESA/SCC Basic Specification No. 23500. For chip carrier packages the finish shall be Type '2' in accordance with ESA/SCC Basic Specification No. 23500. For SO ceramic packages, the material shall be Type 'G' with either Type '2' or Type '4' finish in accordance with ESA/SCC Basic Specification No. 23500. (See Table 1(a) for Type Variants).

4.5 MARKING

4.5.1 General

The marking of all components delivered to this specification shall be in accordance with the requirements of ESA/SCC Basic Specification No. 21700. Each component shall be marked in respect of:-

- (a) Lead Identification.
- (b) The SCC Component Number.
- (c) Traceability Information.

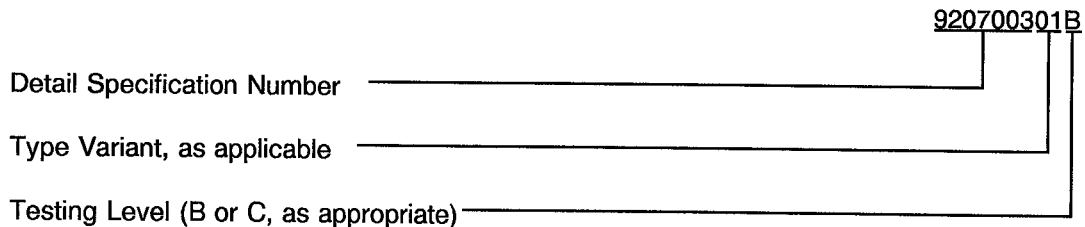
4.5.2 Lead Identification

For dual-in-line, flat and SO packages, an index shall be located at the top of the package in the position defined in Note 1 to Figure 2 or, alternatively, a tab may be used to identify Pin No. 1. The pin numbering must be read with the index or tab on the left-hand side. For chip carrier packages, the index shall be as defined by Figure 2(c).



4.5.3 The SCC Component Number

Each component shall bear the SCC Component Number which shall be constituted and marked as follows:



4.5.4 Traceability Information

Each component shall be marked in respect of traceability information in accordance with the requirements of ESA/SCC Basic Specification No. 21700.

4.6 ELECTRICAL MEASUREMENTS

4.6.1 Electrical Measurements at Room Temperature

The parameters to be measured in respect of electrical characteristics are scheduled in Table 2. Unless otherwise specified, the measurements shall be performed at $T_{amb} = +22 \pm 3$ °C.

4.6.2 Electrical Measurements at High and Low Temperatures

The parameters to be measured at high and low temperatures are scheduled in Table 3. The measurements shall be performed at $T_{amb} = +125(+0-5)$ °C and $-55(+5-0)$ °C respectively.

4.6.3 Circuits for Electrical Measurements

Circuits and functional test sequence for use in performing electrical measurements listed in Tables 2 and 3 of this specification are shown in Figure 4.

4.7 BURN-IN TESTS

4.7.1 Parameter Drift Values

The parameter drift values applicable to burn-in are specified in Table 4 of this specification. Unless otherwise stated, measurements shall be performed at $+22 \pm 3$ °C. The parameter drift values (Δ) applicable to the parameters scheduled, shall not be exceeded. In addition to these drift value requirements, the appropriate limit value specified for a given parameter in Table 2 shall not be exceeded.

4.7.2 Conditions for H.T.R.B. and Burn-in

The requirements for H.T.R.B. and Burn-in are specified in Section 7 of ESA/SCC Generic Specification No. 9000. The conditions for H.T.R.B. and Burn-in shall be as specified in Tables 5(a), 5(b) and 5(c) of this specification.

4.7.3 Electrical Circuits for H.T.R.B and Burn-in

Circuits for use in performing the H.T.R.B. and Burn-in tests are shown in Figures 5(a), 5(b) and 5(c) of this specification.

**TABLE 2 - ELECTRICAL MEASUREMENTS AT ROOM TEMPERATURE - d.c. PARAMETERS**

NO.	CHARACTERISTICS	SYMBOL	TEST METHOD MIL-STD 883	TEST FIG.	TEST CONDITIONS (PINS UNDER TEST D/F = DIP AND FP C = CCP)	LIMITS		UNIT
						MIN	MAX	
1	Functional Test	-	-	4(a)	Verify Truth Table without Load. $V_{DD} = 3V_{dc}$, $V_{SS} = 0V_{dc}$ Notes 1 and 2	-	-	-
2	Functional Test	-	-	4(a)	Verify Truth Table without Load. $V_{DD} = 15V_{dc}$, $V_{SS} = 0V_{dc}$ Notes 1 and 2	-	-	-
3 to 12	Quiescent Current	I_{DD}	3005	4(b)	$V_{IL} = 0V_{dc}$, $V_{IH} = 15V_{dc}$ $V_{DD} = 15V_{dc}$, $V_{SS} = 0V_{dc}$ (Pin D/F 14) (Pin C 20)	-	500	nA
13 to 18	Input Current Low Level	I_{IL}	3009	4(c)	V_{IN} (Under Test) = $0V_{dc}$ V_{IN} (Remaining Inputs) = $15V_{dc}$ $V_{DD} = 15V_{dc}$, $V_{SS} = 0V_{dc}$ (Pins D/F 4-5-6-8-9-12) (Pins C 6-7-9-12-14-17)	-	-50	nA
19 to 24	Input Current High Level	I_{IH}	3010	4(d)	V_{IN} (Under Test) = $15V_{dc}$ V_{IN} (Remaining Inputs) = $0V_{dc}$ $V_{DD} = 15V_{dc}$, $V_{SS} = 0V_{dc}$ (Pins D/F 4-5-6-8-9-12) (Pins C 6-7-9-12-14-17)	-	50	nA
25 to 27	Output Voltage Low Level	V_{OL}	3007	4(e)	$V_{IL} = 0V_{dc}$, $V_{IH} = 15V_{dc}$ $V_{OUT} = \text{Open}$ $V_{DD} = 15V_{dc}$, $V_{SS} = 0V_{dc}$ (Pins D/F 10-11-13) (Pins C 15-16-19)	-	0.05	V
28 to 30	Output Voltage High Level	V_{OH}	3006	4(f)	$V_{IL} = 0V_{dc}$, $V_{IH} = 15V_{dc}$ $V_{OUT} = \text{Open}$ $V_{DD} = 15V_{dc}$, $V_{SS} = 0V_{dc}$ (Pins D/F 10-11-13) (Pins C 15-16-19)	14.95	-	V
31 to 33	Output Drive Current N-Channel	I_{OL1}	-	4(g)	$V_{IL} = 0V_{dc}$, $V_{IH} = 5V_{dc}$ $V_{OUT} = 0.4V_{dc}$ $V_{DD} = 5V_{dc}$, $V_{SS} = 0V_{dc}$ Note 3 (Pins D/F 10-11-13) (Pins C 15-16-19)	0.51	-	mA

NOTES: See Page 24.



TABLE 2 - ELECTRICAL MEASUREMENTS AT ROOM TEMPERATURE - d.c. PARAMETERS (CONT'D)

NO.	CHARACTERISTICS	SYMBOL	TEST METHOD MIL-STD 883	TEST FIG.	TEST CONDITIONS (PINS UNDER TEST D/F = DIP AND FP C = CCP)	LIMITS		UNIT
						MIN	MAX	
34 to 36	Output Drive Current N-Channel	I_{OL2}	-	4(g)	$V_{IL} = 0V_{dc}$, $V_{IH} = 15V_{dc}$ $V_{OUT} = 1.5V_{dc}$ $V_{DD} = 15V_{dc}$, $V_{SS} = 0V_{dc}$ Note 3 (Pins D/F 10-11-13) (Pins C 15-16-19)	3.4	-	mA
37 to 39	Output Drive Current P-Channel	I_{OH1}	-	4(h)	$V_{IL} = 0V_{dc}$, $V_{IH} = 5V_{dc}$ $V_{OUT} = 4.6V_{dc}$ $V_{DD} = 5V_{dc}$, $V_{SS} = 0V_{dc}$ Note 3 (Pins D/F 10-11-13) (Pins C 15-16-19)	-0.51	-	mA
40 to 42	Output Drive Current P-Channel	I_{OH2}	-	4(h)	$V_{IL} = 0V_{dc}$, $V_{IH} = 15V_{dc}$ $V_{OUT} = 13.5V_{dc}$ $V_{DD} = 15V_{dc}$, $V_{SS} = 0V_{dc}$ Note 3 (Pins D/F 10-11-13) (Pins C 15-16-19)	-3.4	-	mA
43	Input Voltage Low Level (Noise Immunity) (Functional Test)	V_{IL1}	-	4(a)	$V_{IL} = 1.5V_{dc}$ $V_{IH} = 3.5V_{dc}$ $V_{DD} = 5V_{dc}$, $V_{SS} = 0V_{dc}$ Note 4 (Pins D/F 10-11-13) (Pins C 15-16-19)	4.5	-	V
	Input Voltage High Level (Noise Immunity) (Functional Test)	V_{IH1}				-	0.5	
44	Input Voltage Low Level (Noise Immunity) (Functional Test)	V_{IL2}	-	4(a)	$V_{IL} = 4V_{dc}$ $V_{IH} = 11V_{dc}$ $V_{DD} = 15V_{dc}$, $V_{SS} = 0V_{dc}$ Note 4 (Pins D/F 10-11-13) (Pins C 15-16-19)	13.5	-	V
	Input Voltage High Level (Noise Immunity) (Functional Test)	V_{IH2}				-	1.5	
45	Threshold Voltage N-Channel	V_{THN}	-	4(i)	Retrigger Input at Ground. Remaining Inputs: $V_{IN} = 5V_{dc}$ $V_{DD} = 5V_{dc}$, $I_{SS} = -10\mu A$ (Pin D/F 7) (Pin C 10)	-0.7	-3.0	V

NOTES: See Page 24.

**TABLE 2 - ELECTRICAL MEASUREMENTS AT ROOM TEMPERATURE - d.c. PARAMETERS (CONT'D)**

NO.	CHARACTERISTICS	SYMBOL	TEST METHOD MIL-STD 883	TEST FIG.	TEST CONDITIONS (PINS UNDER TEST D/F = DIP AND FP C = CCP)	LIMITS		UNIT
						MIN	MAX	
46	Threshold Voltage P-Channel	V_{THP}	-	4(j)	Retrigger Input at Ground. Remaining Inputs: $V_{IN} = -5Vdc$ $V_{SS} = -5Vdc$, $I_{DD} = 10\mu A$ (Pin D/F 14) (Pin C 20)	0.7	3.0	V
47 to 52	Input Clamp Voltage (to V_{SS})	V_{IC1}	-	4(k)	I_{IN} (Under Test) = $-100\mu A$ $V_{DD} = Open$, $V_{SS} = 0Vdc$ All Other Pins Open (Pins D/F 4-5-6-8-9-12) (Pins C 6-7-9-12-14-17)	-	-2.0	V
53 to 58	Input Clamp Voltage (to V_{DD})	V_{IC2}	-	4(l)	V_{IN} (Under Test) = $6Vdc$ $V_{SS} = Open$, $R = 30k\Omega$ (Pins D/F 4-5-6-8-9-12) (Pins C 6-7-9-12-14-17)	3.0	-	V

NOTES: See Page 24.

**TABLE 2 - ELECTRICAL MEASUREMENTS AT ROOM TEMPERATURE - a.c. PARAMETERS**

NO.	CHARACTERISTICS	SYMBOL	TEST METHOD MIL-STD 883	TEST FIG.	TEST CONDITIONS (PINS UNDER TEST D/F = DIP AND FP C = CCP)	LIMITS		UNIT
						MIN	MAX	
59 to 64	Input Capacitance	C_{IN}	3012	4(m)	V_{IN} (Not Under Test) = 0Vdc $V_{DD} = V_{SS} = 0Vdc$ Note 5 (Pins D/F 4-5-6-8-9-12) (Pins C 6-7-9-12-14-17)	-	7.5	pF
65	Propagation Delay Low to High (+ Trigger to Q)	t_{PLH}	3003	4(n)	V_{IN} (Under Test) = Pulse Generator $V_{DD} = 5Vdc, V_{SS} = 0Vdc$ Note 6 <u>Pins D/F</u> <u>Pins C</u> 8 to 10 12 to 15	-	1100	ns
66	Propagation Delay High to Low (+ Trigger to \bar{Q})	t_{PHL}	3003	4(n)	V_{IN} (Under Test) = Pulse Generator $V_{DD} = 5Vdc, V_{SS} = 0Vdc$ Note 6 <u>Pins D/F</u> <u>Pins C</u> 8 to 11 12 to 16	-	1100	ns
67 to 68	Transition Time Low to High Oscillator Outputs Q and \bar{Q}	t_{TLH}	3004	4(n)	V_{IN} (Under Test) = Pulse Generator $V_{DD} = 5Vdc, V_{SS} = 0Vdc$ Note 6 (Pins D/F 10-11) (Pins C 15-16)	-	150	ns
69 to 70	Transition Time High to Low Oscillator Outputs Q and \bar{Q}	t_{THL}	3004	4(n)	V_{IN} (Under Test) = Pulse Generator $V_{DD} = 5Vdc, V_{SS} = 0Vdc$ Note 6 (Pins D/F 10-11) (Pins C 15-16)	-	150	ns

NOTES: See Page 24.

**SCC**ESA/SCC Detail Specification
No. 9207/003

PAGE 24

ISSUE 3

TABLE 2 - ELECTRICAL MEASUREMENTS AT ROOM TEMPERATURE (CONTINUED)**NOTES**

1. GO-NO-GO Test, each pattern of Test Table 4(a).
 $V_{OH} \geq V_{DD} - 0.5V_{dc}$ $V_{OL} \leq 0.5V_{dc}$
2. Maximum time to output comparator strobe 300 μ sec.
3. Interchange of forcing and measuring function is permitted.
4. This is performed as a Functional Test in which extreme V_{IN} conditions are applied and output voltage is measured.
5. Measurement performed on a sample basis, LTPD7 or less, with a Capacitance Bridge connected between each input or output under test and V_{SS} , only for Lots where LAT Level 2 is to be performed. (For LTPD sampling plan, see Annexe I of ESA/SCC 9000).
6. Measurement performed on a sample basis, LTPD7 or less, (see Annexe I of ESA/SCC 9000).



TABLE 3(a) - ELECTRICAL MEASUREMENTS AT HIGH TEMPERATURE, +125(+0-5) °C

NO.	CHARACTERISTICS	SYMBOL	TEST METHOD MIL-STD 883	TEST FIG.	TEST CONDITIONS (PINS UNDER TEST D/F = DIP AND FP C = CCP)	LIMITS		UNIT
						MIN	MAX	
1	Functional Test	-	-	4(a)	Verify Truth Table without Load. $V_{DD} = 3V_{dc}$, $V_{SS} = 0V_{dc}$ Notes 1 and 2	-	-	-
2	Functional Test	-	-	4(a)	Verify Truth Table without Load. $V_{DD} = 15V_{dc}$, $V_{SS} = 0V_{dc}$ Notes 1 and 2	-	-	-
3 to 12	Quiescent Current	I_{DD}	3005	4(b)	$V_{IL} = 0V_{dc}$, $V_{IH} = 15V_{dc}$ $V_{DD} = 15V_{dc}$, $V_{SS} = 0V_{dc}$ (Pin D/F 14) (Pin C 20)	-	15	μA
13 to 18	Input Current Low Level	I_{IL}	3009	4(c)	V_{IN} (Under Test) = $0V_{dc}$ V_{IN} (Remaining Inputs) = $15V_{dc}$ $V_{DD} = 15V_{dc}$, $V_{SS} = 0V_{dc}$ (Pins D/F 4-5-6-8-9-12) (Pins C 6-7-9-12-14-17)	-	-100	nA
19 to 24	Input Current High Level	I_{IH}	3010	4(d)	V_{IN} (Under Test) = $15V_{dc}$ V_{IN} (Remaining Inputs) = $0V_{dc}$ $V_{DD} = 15V_{dc}$, $V_{SS} = 0V_{dc}$ (Pins D/F 4-5-6-8-9-12) (Pins C 6-7-9-12-14-17)	-	100	nA
25 to 27	Output Voltage Low Level	V_{OL}	3007	4(e)	$V_{IL} = 0V_{dc}$, $V_{IH} = 15V_{dc}$ $V_{OUT} = \text{Open}$ $V_{DD} = 15V_{dc}$, $V_{SS} = 0V_{dc}$ (Pins D/F 10-11-13) (Pins C 15-16-19)	-	0.05	V
28 to 30	Output Voltage High Level	V_{OH}	3006	4(f)	$V_{IL} = 0V_{dc}$, $V_{IH} = 15V_{dc}$ $V_{OUT} = \text{Open}$ $V_{DD} = 15V_{dc}$, $V_{SS} = 0V_{dc}$ (Pins D/F 10-11-13) (Pins C 15-16-19)	14.95	-	V
31 to 33	Output Drive Current N-Channel	I_{OL1}	-	4(g)	$V_{IL} = 0V_{dc}$, $V_{IH} = 5V_{dc}$ $V_{OUT} = 0.4V_{dc}$ $V_{DD} = 5V_{dc}$, $V_{SS} = 0V_{dc}$ Note 3 (Pins D/F 10-11-13) (Pins C 15-16-19)	0.36	-	mA

NOTES: See Page 24.



TABLE 3(a) - ELECTRICAL MEASUREMENTS AT HIGH TEMPERATURE, + 125(+ 0-5) °C (CONT'D)

NO.	CHARACTERISTICS	SYMBOL	TEST METHOD MIL-STD 883	TEST FIG.	TEST CONDITIONS (PINS UNDER TEST D/F = DIP AND FP C = CCP)	LIMITS		UNIT
						MIN	MAX	
34 to 36	Output Drive Current N-Channel	I _{OL2}	-	4(g)	V _{IL} = 0Vdc, V _{IH} = 15Vdc V _{OUT} = 1.5Vdc V _{DD} = 15Vdc, V _{SS} = 0Vdc Note 3 (Pins D/F 10-11-13) (Pins C 15-16-19)	2.4	-	mA
37 to 39	Output Drive Current P-Channel	I _{OH1}	-	4(h)	V _{IL} = 0Vdc, V _{IH} = 5Vdc V _{OUT} = 4.6Vdc V _{DD} = 5Vdc, V _{SS} = 0Vdc Note 3 (Pins D/F 10-11-13) (Pins C 15-16-19)	-0.36	-	mA
40 to 42	Output Drive Current P-Channel	I _{OH2}	-	4(h)	V _{IL} = 0Vdc, V _{IH} = 15Vdc V _{OUT} = 13.5Vdc V _{DD} = 15Vdc, V _{SS} = 0Vdc Note 3 (Pins D/F 10-11-13) (Pins C 15-16-19)	-2.4	-	mA
43	Input Voltage Low Level (Noise Immunity) (Functional Test)	V _{IL1}	-	4(a)	V _{IL} = 1.5Vdc V _{IH} = 3.5Vdc V _{DD} = 5Vdc, V _{SS} = 0Vdc Note 4 (Pins D/F 10-11-13) (Pins C 15-16-19)	4.5	-	V
	Input Voltage High Level (Noise Immunity) (Functional Test)	V _{IH1}				-	0.5	
44	Input Voltage Low Level (Noise Immunity) (Functional Test)	V _{IL2}	-	4(a)	V _{IL} = 4Vdc V _{IH} = 11Vdc V _{DD} = 15Vdc, V _{SS} = 0Vdc Note 4 (Pins D/F 10-11-13) (Pins C 15-16-19)	13.5	-	V
	Input Voltage High Level (Noise Immunity) (Functional Test)	V _{IH2}				-	1.5	
45	Threshold Voltage N-Channel	V _{THN}	-	4(i)	Retrigger Input at Ground. Remaining Inputs: V _{IN} = 5Vdc V _{DD} = 5Vdc, I _{SS} = -10μA (Pin D/F 7) (Pin C 10)	-0.3	-3.5	V

NOTES: See Page 24.



TABLE 3(a) - ELECTRICAL MEASUREMENTS AT HIGH TEMPERATURE, + 125(+ 0-5) °C (CONT'D)

NO.	CHARACTERISTICS	SYMBOL	TEST METHOD MIL-STD 883	TEST FIG.	TEST CONDITIONS (PINS UNDER TEST D/F = DIP AND FP C = CCP)	LIMITS		UNIT
						MIN	MAX	
46	Threshold Voltage P-Channel	V_{THP}	-	4(j)	Retrigger Input at Ground. Remaining Inputs: $V_{IN} = -5Vdc$ $V_{SS} = -5Vdc, I_{DD} = 10\mu A$ (Pin D/F 14) (Pin C 20)	0.3	3.5	V

NOTES: See Page 24.

**TABLE 3(b) - ELECTRICAL MEASUREMENTS AT LOW TEMPERATURE, -55(+5-0) °C**

NO.	CHARACTERISTICS	SYMBOL	TEST METHOD MIL-STD 883	TEST FIG.	TEST CONDITIONS (PINS UNDER TEST D/F = DIP AND FP C = CCP)	LIMITS		UNIT
						MIN	MAX	
1	Functional Test	-	-	4(a)	Verify Truth Table without Load. $V_{DD} = 3V_{dc}$, $V_{SS} = 0V_{dc}$ Notes 1 and 2	-	-	-
2	Functional Test	-	-	4(a)	Verify Truth Table without Load. $V_{DD} = 15V_{dc}$, $V_{SS} = 0V_{dc}$ Notes 1 and 2	-	-	-
3 to 12	Quiescent Current	I_{DD}	3005	4(b)	$V_{IL} = 0V_{dc}$, $V_{IH} = 15V_{dc}$ $V_{DD} = 15V_{dc}$, $V_{SS} = 0V_{dc}$ (Pin D/F 14) (Pin C 20)	-	500	nA
13 to 18	Input Current Low Level	I_{IL}	3009	4(c)	V_{IN} (Under Test) = $0V_{dc}$ V_{IN} (Remaining Inputs) = $15V_{dc}$ $V_{DD} = 15V_{dc}$, $V_{SS} = 0V_{dc}$ (Pins D/F 4-5-6-8-9-12) (Pins C 6-7-9-12-14-17)	-	-50	nA
19 to 24	Input Current High Level	I_{IH}	3010	4(d)	V_{IN} (Under Test) = $15V_{dc}$ V_{IN} (Remaining Inputs) = $0V_{dc}$ $V_{DD} = 15V_{dc}$, $V_{SS} = 0V_{dc}$ (Pins D/F 4-5-6-8-9-12) (Pins C 6-7-9-12-14-17)	-	50	nA
25 to 27	Output Voltage Low Level	V_{OL}	3007	4(e)	$V_{IL} = 0V_{dc}$, $V_{IH} = 15V_{dc}$ $V_{OUT} = \text{Open}$ $V_{DD} = 15V_{dc}$, $V_{SS} = 0V_{dc}$ (Pins D/F 10-11-13) (Pins C 15-16-19)	-	0.05	V
28 to 30	Output Voltage High Level	V_{OH}	3006	4(f)	$V_{IL} = 0V_{dc}$, $V_{IH} = 15V_{dc}$ $V_{OUT} = \text{Open}$ $V_{DD} = 15V_{dc}$, $V_{SS} = 0V_{dc}$ (Pins D/F 10-11-13) (Pins C 15-16-19)	14.95	-	V
31 to 33	Output Drive Current N-Channel	I_{OL1}	-	4(g)	$V_{IL} = 0V_{dc}$, $V_{IH} = 5V_{dc}$ $V_{OUT} = 0.4V_{dc}$ $V_{DD} = 5V_{dc}$, $V_{SS} = 0V_{dc}$ Note 3 (Pins D/F 10-11-13) (Pins C 15-16-19)	0.64	-	mA

NOTES: See Page 24.



TABLE 3(b) - ELECTRICAL MEASUREMENTS AT LOW TEMPERATURE, -55(+5-0) °C (CONT'D)

NO.	CHARACTERISTICS	SYMBOL	TEST METHOD MIL-STD 883	TEST FIG.	TEST CONDITIONS (PINS UNDER TEST D/F = DIP AND FP C = CCP)	LIMITS		UNIT
						MIN	MAX	
34 to 36	Output Drive Current N-Channel	I_{OL2}	-	4(g)	$V_{IL} = 0V_{dc}$, $V_{IH} = 15V_{dc}$ $V_{OUT} = 1.5V_{dc}$ $V_{DD} = 15V_{dc}$, $V_{SS} = 0V_{dc}$ Note 3 (Pins D/F 10-11-13) (Pins C 15-16-19)	4.2	-	mA
37 to 39	Output Drive Current P-Channel	I_{OH1}	-	4(h)	$V_{IL} = 0V_{dc}$, $V_{IH} = 5V_{dc}$ $V_{OUT} = 4.6V_{dc}$ $V_{DD} = 5V_{dc}$, $V_{SS} = 0V_{dc}$ Note 3 (Pins D/F 10-11-13) (Pins C 15-16-19)	-0.64	-	mA
40 to 42	Output Drive Current P-Channel	I_{OH2}	-	4(h)	$V_{IL} = 0V_{dc}$, $V_{IH} = 15V_{dc}$ $V_{OUT} = 13.5V_{dc}$ $V_{DD} = 15V_{dc}$, $V_{SS} = 0V_{dc}$ Note 3 (Pins D/F 10-11-13) (Pins C 15-16-19)	-4.2	-	mA
43	Input Voltage Low Level (Noise Immunity) (Functional Test)	V_{IL1}	-	4(a)	$V_{IL} = 1.5V_{dc}$ $V_{IH} = 3.5V_{dc}$ $V_{DD} = 5V_{dc}$, $V_{SS} = 0V_{dc}$ Note 4 (Pins D/F 10-11-13) (Pins C 15-16-19)	4.5	-	V
	Input Voltage High Level (Noise Immunity) (Functional Test)	V_{IH1}				-	0.5	
44	Input Voltage Low Level (Noise Immunity) (Functional Test)	V_{IL2}	-	4(a)	$V_{IL} = 4V_{dc}$ $V_{IH} = 11V_{dc}$ $V_{DD} = 15V_{dc}$, $V_{SS} = 0V_{dc}$ Note 4 (Pins D/F 10-11-13) (Pins C 15-16-19)	13.5	-	V
	Input Voltage High Level (Noise Immunity) (Functional Test)	V_{IH2}				-	1.5	
45	Threshold Voltage N-Channel	V_{THN}	-	4(i)	Retrigger Input at Ground. Remaining Inputs: $V_{IN} = 5V_{dc}$ $V_{DD} = 5V_{dc}$, $I_{SS} = -10\mu A$ (Pin D/F 7) (Pin C 10)	-0.7	-3.5	V

NOTES: See Page 24.

**SEC**ESA/SCC Detail Specification
No. 9207/003

PAGE 30

ISSUE 3

TABLE 3(b) - ELECTRICAL MEASUREMENTS AT LOW TEMPERATURE, -55(+5-0) °C (CONT'D)

NO.	CHARACTERISTICS	SYMBOL	TEST METHOD MIL-STD 883	TEST FIG.	TEST CONDITIONS (PINS UNDER TEST D/F = DIP AND FP C = CCP)	LIMITS		UNIT
						MIN	MAX	
46	Threshold Voltage P-Channel	V_{THP}	-	4(j)	Retrigger Input at Ground. Remaining Inputs: $V_{IN} = -5Vdc$ $V_{SS} = -5Vdc, I_{DD} = 10\mu A$ (Pin D/F 14) (Pin C 20)	0.7	3.5	V

NOTES: See Page 24.



FIGURE 4 - CIRCUITS FOR ELECTRICAL MEASUREMENTS

FIGURE 4(a) - FUNCTIONAL TEST TABLE

PATTERN NO.	PIN NUMBERS												D.C. SUPPLY	
	1	2	3	4	5	6	8	9	10	11	12	13	7	14
1	1	0	1	1	1	1	1	1	0	1	0	1	0	V _{DD}
2	1	0	1	1	1	1	1	0	0	1	0	1		
3	0	1	0	1	1	1	1	0	0	1	0	0		
4	0	1	1	1	0	1	1	0	0	1	0	0		
5	1	0	1	0	0	1	1	0	1	0	0	1		
6	1	0	1	1	0	1	1	0	1	0	0	1		
7	0	1	0	1	0	1	1	0	1	0	0	0		
8	0	1	0	1	0	0	1	0	1	0	0	0		
9	0	1	0	1	1	0	1	0	1	0	0	0		
10	1	0	1	1	1	0	1	0	0	1	0	1		
11	0	1	1	1	0	0	1	0	0	1	0	0		
12	0	1	1	1	0	0	1	0	0	1	0	0		
13	0	1	1	1	0	0	0	0	0	1	0	0		
14	1	0	1	1	0	0	1	0	1	0	0	1		
15	1	0	1	1	0	1	1	0	1	0	0	1		
16	0	1	0	1	0	1	1	0	1	0	0	0		
17	0	1	0	1	1	1	1	0	1	0	0	0		
18	0	1	0	1	1	0	1	0	1	0	0	0		
19	1	0	1	1	1	0	1	0	0	1	0	1		
20	0	1	1	1	0	0	1	0	0	1	0	0		
21	0	1	1	1	0	0	1	0	0	1	0	0		
22	0	1	1	1	0	1	1	0	0	1	0	0		
23	1	0	1	1	0	0	1	0	1	0	0	1		
24	1	0	1	1	0	0	1	1	0	1	0	1		
25	1	0	1	1	0	0	1	0	0	1	0	1		
26	1	0	1	1	1	0	1	0	0	1	0	1		
27	1	0	1	1	1	0	1	0	1	0	1	1		
28	1	0	1	1	1	0	1	0	1	0	0	1		
29	0	1	0	1	1	0	1	0	1	0	0	0		
30	1	0	1	1	1	0	1	0	0	1	0	1		

NOTES: See Page 31.



FIGURE 4 - CIRCUITS FOR ELECTRICAL MEASUREMENTS (CONTINUED)

FIGURE 4(a) - FUNCTIONAL TEST TABLE (CONTINUED)

PATTERN NO.	PIN NUMBERS												D.C. SUPPLY	
	1	2	3	4	5	6	8	9	10	11	12	13	7	14
31	0	1	0	1	1	0	1	0	0	1	0	0	0	V _{DD}
32	1	0	1	1	1	0	1	0	1	0	0	1	↓	↓
33	0	1	0	1	1	0	1	0	1	0	0	0	↓	↓
34	0	1	0	1	1	0	1	0	1	0	1	0	↓	↓
35	0	1	0	1	1	0	1	0	1	0	0	0	↓	↓
36	1	0	1	1	1	0	1	0	1	0	0	1	↓	↓
37	0	1	0	1	1	0	1	0	1	0	0	0	↓	↓
38	1	0	1	1	1	0	1	0	0	1	0	1	↓	↓
39	0	1	0	1	1	0	1	0	0	1	0	0	↓	↓
40	1	0	1	1	1	0	1	0	1	0	0	1	↓	↓
41	1	0	1	1	1	0	1	0	1	0	1	1	↓	↓
42	1	0	1	1	1	0	1	0	1	0	0	1	↓	↓
43	0	1	0	1	1	0	1	0	1	0	0	0	↓	↓
44	1	0	1	1	1	0	1	0	1	0	0	1	↓	↓
45	0	1	0	1	1	0	1	0	1	0	0	0	↓	↓
46	1	0	1	1	1	0	1	0	0	1	0	1	↓	↓

NOTES

1. Figure 4(a) illustrates one series of Test Patterns. Any other pattern series must be agreed with the Qualifying Space Agency and shall be included as an Appendix.
2. Logic Level Definitions: 1 = V_{IH} = V_{DD}, 0 = V_{IL} = V_{SS}.



FIGURE 4 - CIRCUITS FOR ELECTRICAL MEASUREMENTS (CONTINUED)

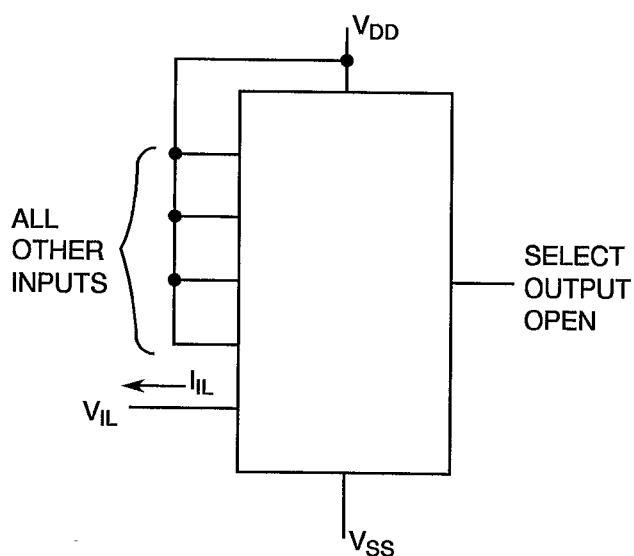
FIGURE 4(b) - QUIESCENT CURRENT

PATTERN NO.	PIN NUMBERS										D.C. SUPPLY	
	INPUTS							OUTPUTS				
	3	4	5	6	8	9	12	10	11	13	7	14
1	1	1	0	0	0	1	0	X	X	X	V _{SS}	V _{DD}
2	1	1	1	1	1	1	0	X	X	X		
3	1	0	0	0	0	1	0	X	X	X		
4	1	1	0	0	1	1	0	X	X	X		
5	0	1	0	0	1	0	0	X	X	X		
6	1	1	0	0	1	0	0	X	X	X		
7	1	1	0	0	1	0	1	X	X	X		
8	0	1	0	0	1	0	0	X	X	X		
9	1	1	0	0	1	0	0	X	X	X		
10	1	1	0	0	0	0	0	X	X	X		

NOTES

- Figure 4(b) illustrates one series of Test Patterns. Any other pattern series must be agreed with the Qualifying Space Agency and shall be included as an Appendix.
- Logic Level Definitions: 1 = V_{IH} = V_{DD}, 0 = V_{IL} = V_{SS}, X = Don't Care.

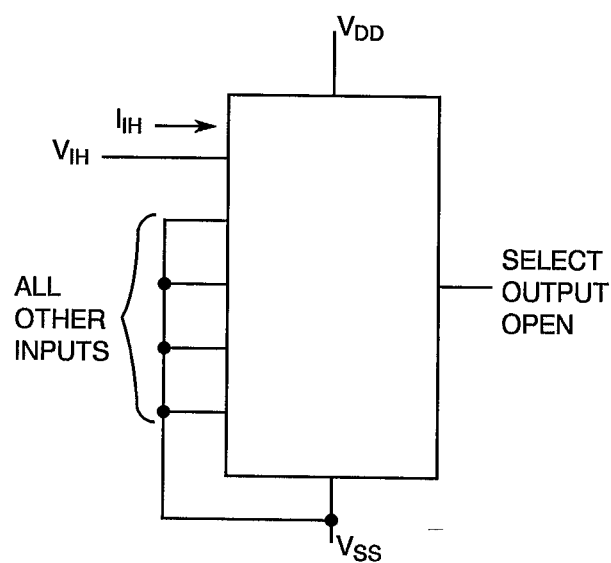
FIGURE 4(c) - LOW LEVEL INPUT CURRENT



NOTES

- Each input to be tested separately.

FIGURE 4(d) - HIGH LEVEL INPUT CURRENT



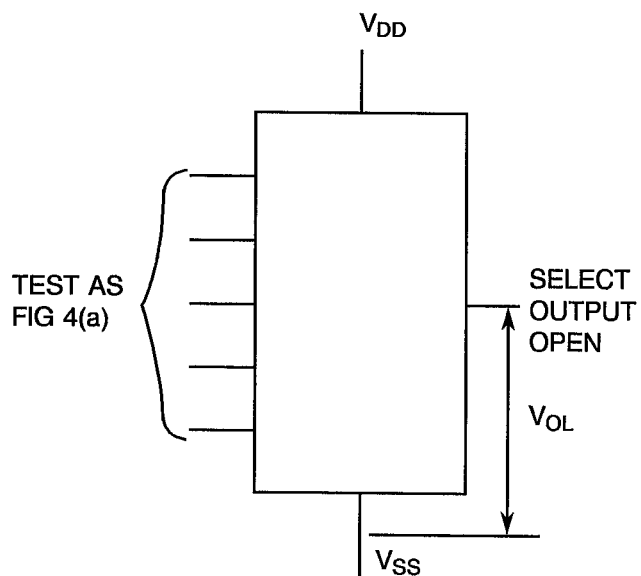
NOTES

- Each input to be tested separately.



FIGURE 4 - CIRCUITS FOR ELECTRICAL MEASUREMENTS (CONTINUED)

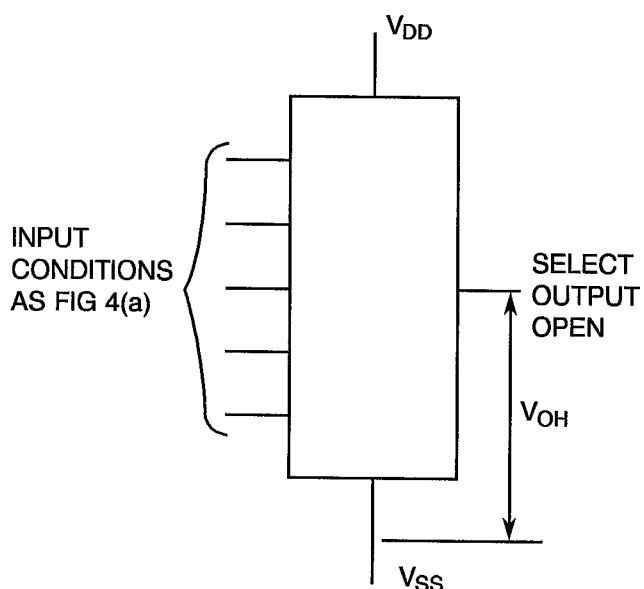
FIGURE 4(e) - LOW LEVEL OUTPUT VOLTAGE



NOTES

1. Each output to be tested separately.

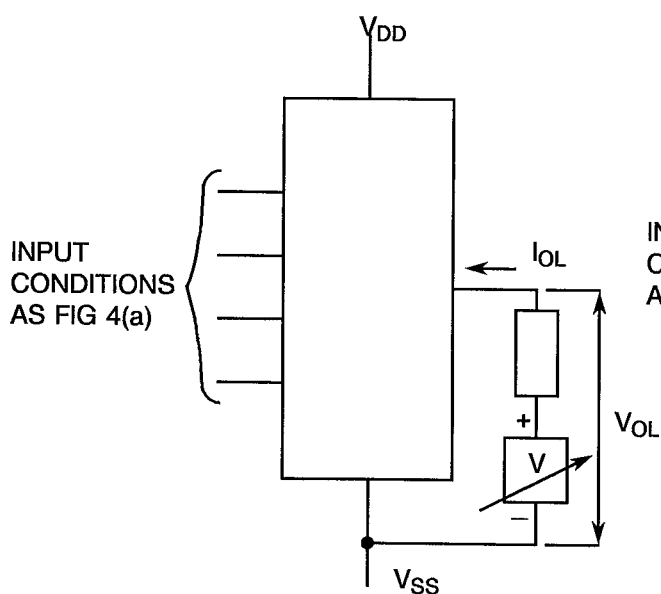
FIGURE 4(f) - HIGH LEVEL OUTPUT VOLTAGE



NOTES

1. Each output to be tested separately.

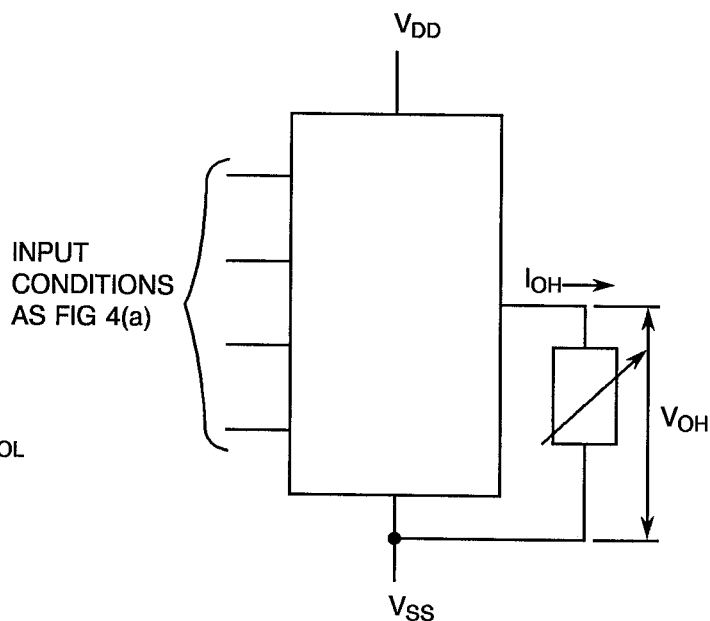
FIGURE 4(g) - OUTPUT DRIVE N-CHANNEL



NOTES

1. Each output to be tested separately.

FIGURE 4(h) - OUTPUT DRIVE P-CHANNEL



NOTES

1. Each output to be tested separately.



FIGURE 4 - CIRCUITS FOR ELECTRICAL MEASUREMENTS (CONTINUED)

FIGURE 4(i) - THRESHOLD VOLTAGE N-CHANNEL

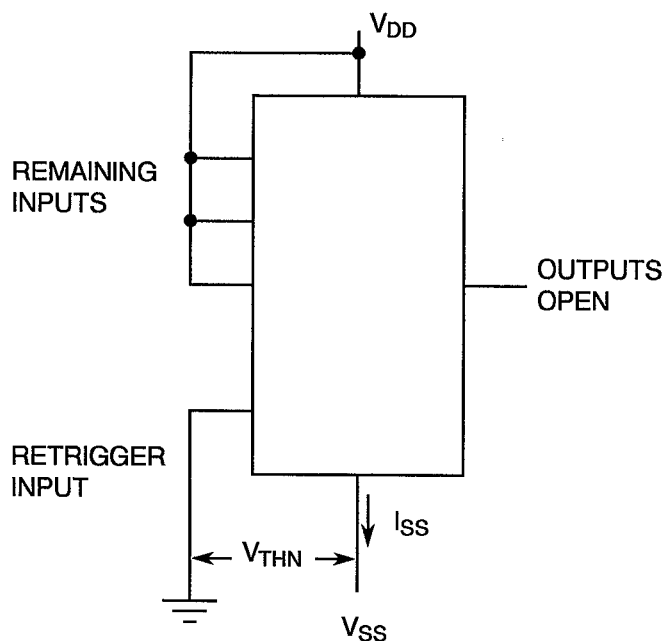


FIGURE 4(j) - THRESHOLD VOLTAGE P-CHANNEL

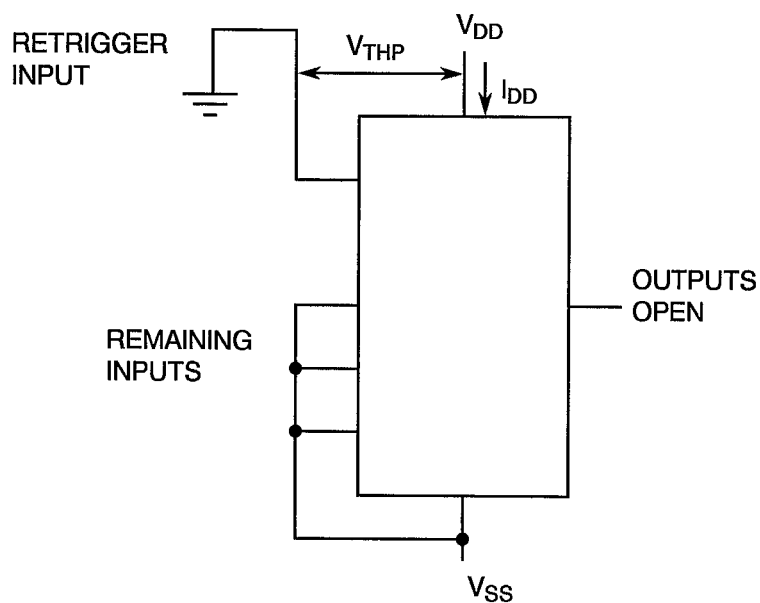
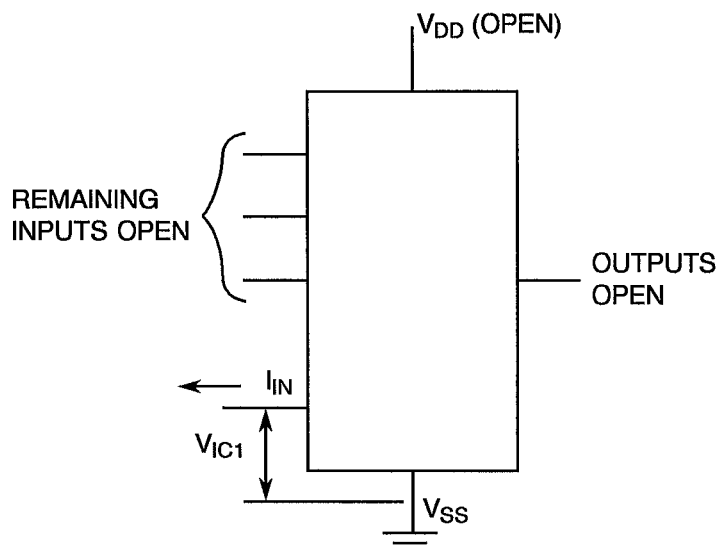




FIGURE 4 - CIRCUITS FOR ELECTRICAL MEASUREMENTS (CONTINUED)

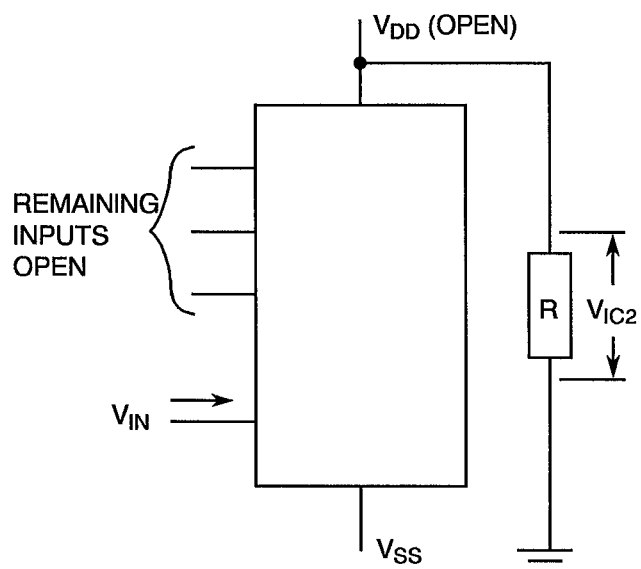
FIGURE 4(k) - INPUT CLAMP VOLTAGE (V_{SS})



NOTES

1. Each input to be tested separately.

FIGURE 4(l) - INPUT CLAMP VOLTAGE (V_{DD})



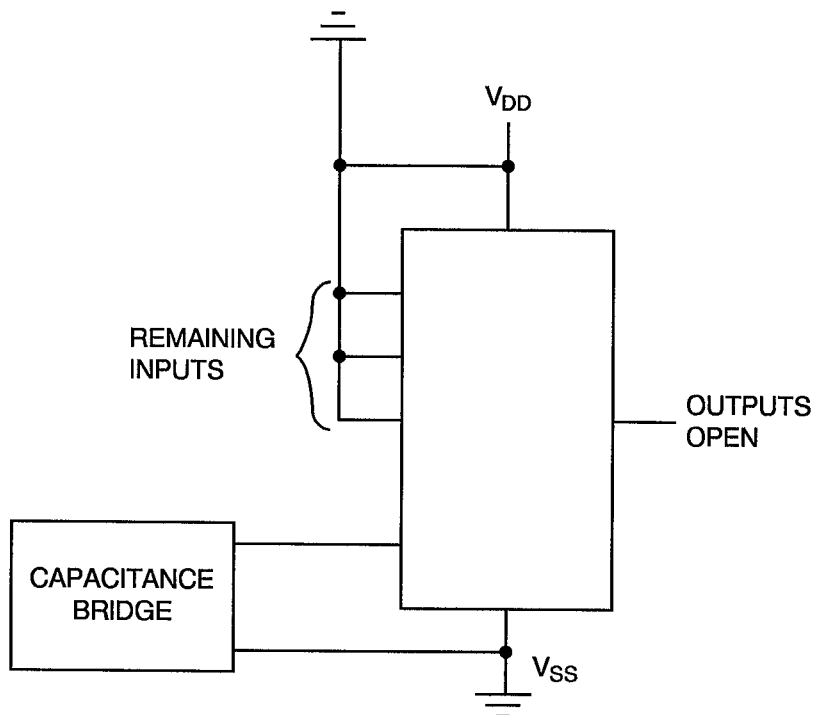
NOTES

1. Each input to be tested separately.



FIGURE 4 - CIRCUITS FOR ELECTRICAL MEASUREMENTS (CONTINUED)

FIGURE 4(m) - INPUT CAPACITANCE



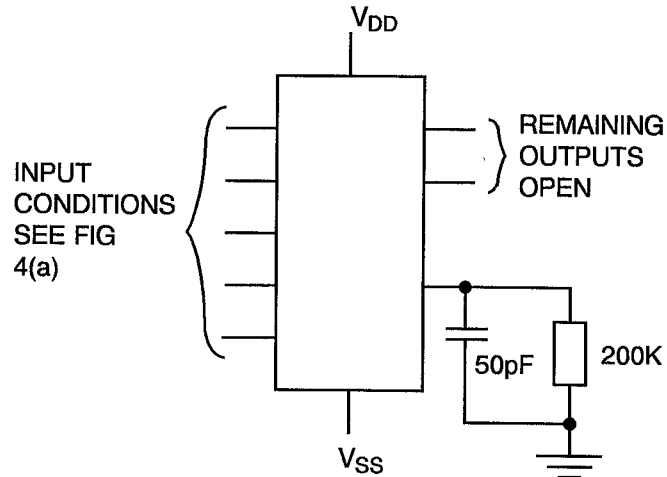
NOTES

1. Each input to be tested separately.
2. $f = 100\text{kHz to } 1\text{MHz}$.



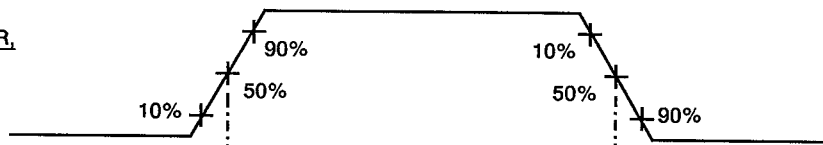
FIGURE 4 - CIRCUITS FOR ELECTRICAL MEASUREMENTS (CONTINUED)

FIGURE 4(n) - PROPAGATION DELAY AND TRANSITION TIME



VOLTAGE WAVEFORMS

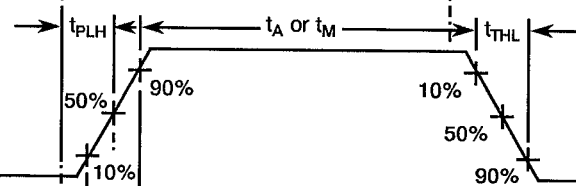
INPUT WAVEFORM
ASTABLE, + TRIGGER,
EXTERNAL RESET
RETRIGGER



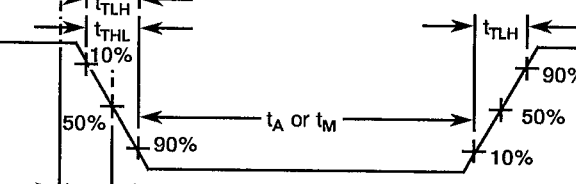
INPUT WAVEFORM
ASTABLE, - TRIGGER



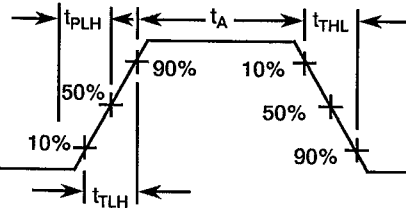
OUTPUT WAVEFORM, Q



OUTPUT WAVEFORM, Q̄



OUTPUT, OSCILLATOR



NOTES 1. Pulse Generator - $V_p = 0$ to V_{DD} , t_r and $t_f \leq 15ns$, $f = 500kHz$.

**TABLE 4 - PARAMETER DRIFT VALUES**

NO.	CHARACTERISTICS	SYMBOL	SPEC. AND/OR TEST METHOD	TEST CONDITIONS	CHANGE LIMITS (Δ)	UNIT
3 to 12	Quiescent Current	I_{DD}	As per Table 2	As per Table 2	± 75	nA
31 to 33	Output Drive Current N-Channel	I_{OL1}	As per Table 2	As per Table 2	± 15 (1)	%
37 to 39	Output Drive Current P-Channel	I_{OH1}	As per Table 2	As per Table 2	± 15 (1)	%
45	Threshold Voltage N-Channel	V_{THN}	As per Table 2	As per Table 2	± 0.3	V
46	Threshold Voltage P-Channel	V_{THP}	As per Table 2	As per Table 2	± 0.3	V

NOTES

1. Percentage of limit value if voltage is the measurement function.

**TABLE 5(a) - CONDITIONS FOR BURN-IN HIGH TEMPERATURE REVERSE BIAS, N-CHANNELS**

NO.	CHARACTERISTICS	SYMBOL	CONDITION	UNIT
1	Ambient Temperature	T_{amb}	+ 125(+ 0-5)	°C
2	Outputs - (Pins D/F 1-2-10-11-13) (Pins C 2-4-15-16-19)	V_{OUT}	Open	-
3	Inputs - (Pins D/F 4-5-12) (Pins C 6-7-17)	V_{IN}	Ground	Vdc
4	Inputs - (Pins D/F 3-6-8-9) (Pins C 5-9-12-14)	V_{IN}	V_{DD}	Vdc
5	Positive Supply Voltage (Pin D/F 14) (Pin C 20)	V_{DD}	15	Vdc
6	Negative Supply Voltage (Pin D/F 7) (Pin C 10)	V_{SS}	Ground	Vdc

NOTES

1. Input Load = Protection Resistor = 2k Ω minimum to 47k Ω maximum.

TABLE 5(b) - CONDITIONS FOR BURN-IN HIGH TEMPERATURE REVERSE BIAS, P-CHANNELS

NO.	CHARACTERISTICS	SYMBOL	CONDITION	UNIT
1	Ambient Temperature	T_{amb}	+ 125(+ 0-5)	°C
2	Outputs - (Pins D/F 1-2-10-11-13) (Pins C 2-4-15-16-19)	V_{OUT}	Open	-
3	Inputs - (Pins D/F 4-5-12) (Pins C 6-7-17)	V_{IN}	V_{DD}	Vdc
4	Inputs - (Pins D/F 3-6-8-9) (Pins C 5-9-12-14)	V_{IN}	Ground	Vdc
5	Positive Supply Voltage (Pin D/F 14) (Pin C 20)	V_{DD}	15	Vdc
6	Negative Supply Voltage (Pin D/F 7) (Pin C 10)	V_{SS}	Ground	Vdc

NOTES

1. Input Load = Protection Resistor = 2k Ω minimum to 47k Ω maximum.

**TABLE 5(c) - CONDITIONS FOR BURN-IN DYNAMIC**

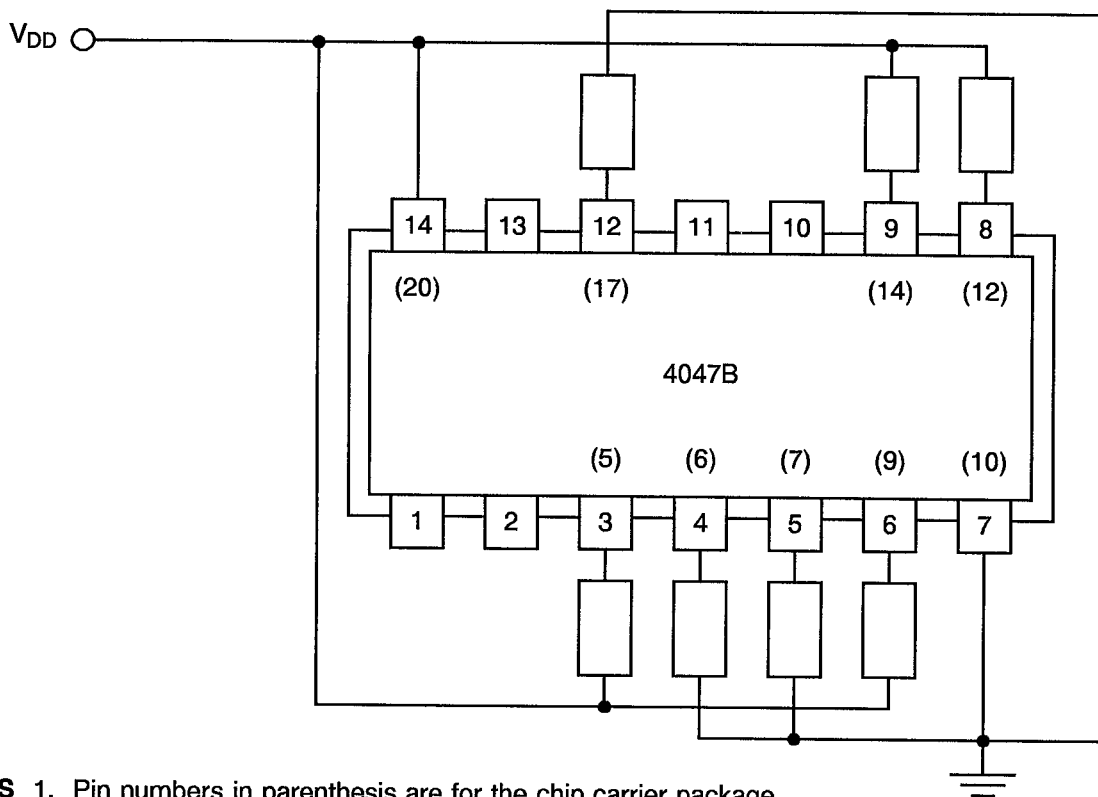
NO.	CHARACTERISTICS	SYMBOL	CONDITIONS	UNIT
1	Ambient Temperature	T_{amb}	+ 125(+ 0-5)	°C
2	Outputs - (Pins D/F 1-2-10-11-13) (Pins C 2-4-15-16-19)	V_{OUT}	Ground	Vdc
3	Inputs - (Pins D/F 4-5) (Pins C 6-7)	V_{IN}	V_{DD}	Vdc
4	Inputs - (Pins D/F 9-12) (Pins C 14-17)	V_{IN}	V_{SS}	Vdc
5	Inputs - (Pins D/F 6-8) (Pins C 9-12)	V_{IN}	V_{GEN1}	Vac
6	Input - (Pin D/F 3) (Pin C 5)	V_{IN}	V_{GEN2}	Vac
7	Pulse Voltage	V_{GEN}	0 to $V_{DD}/2$	Vac
8	Pulse Frequency Square Wave	f_{GEN1} f_{GEN2}	100K 50% Duty Cycle 50K 50% Duty Cycle	Hz
9	Positive Supply Voltage (Pin D/F 14) (Pin C 20)	V_{DD}	7.5	Vdc
10	Negative Supply Voltage (Pin D/F 7) (Pin C 10)	V_{SS}	-7.5	Vdc

NOTES

1. Input Load = Output Load = 2k Ω minimum to 47k Ω maximum.

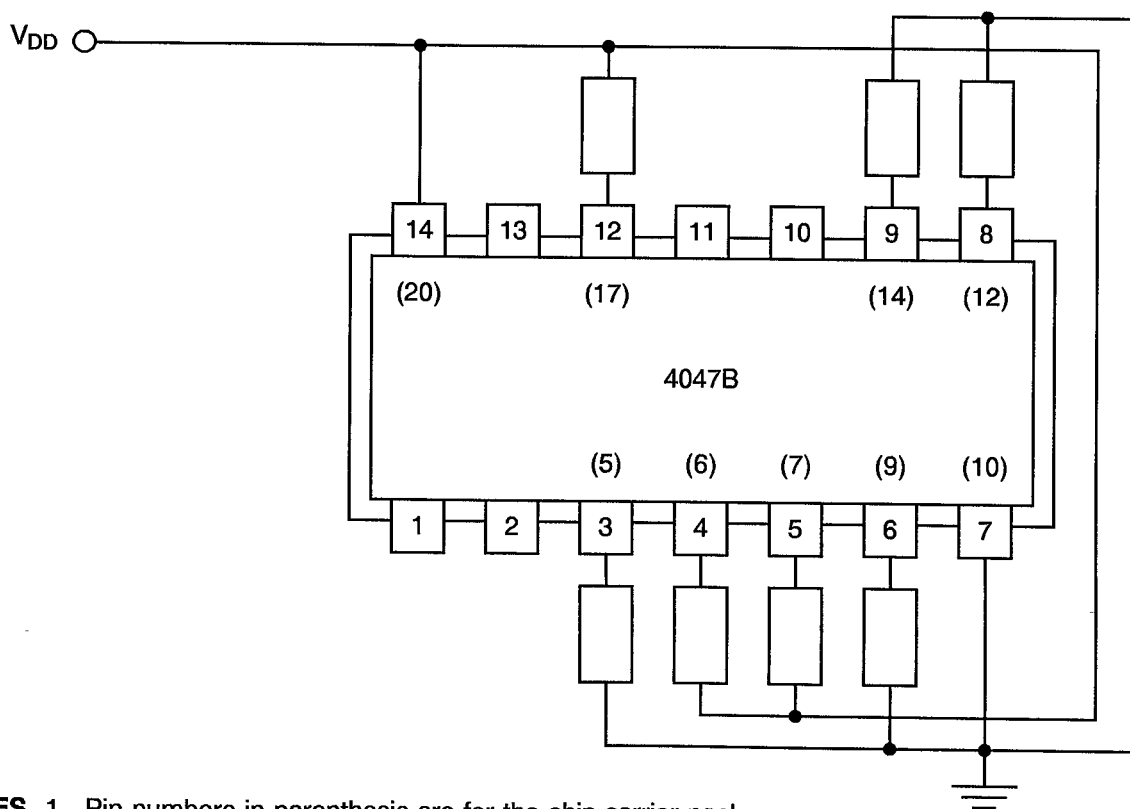


FIGURE 5(a) - ELECTRICAL CIRCUIT FOR BURN-IN HIGH TEMPERATURE REVERSE BIAS, N-CHANNELS



NOTES 1. Pin numbers in parenthesis are for the chip carrier package.

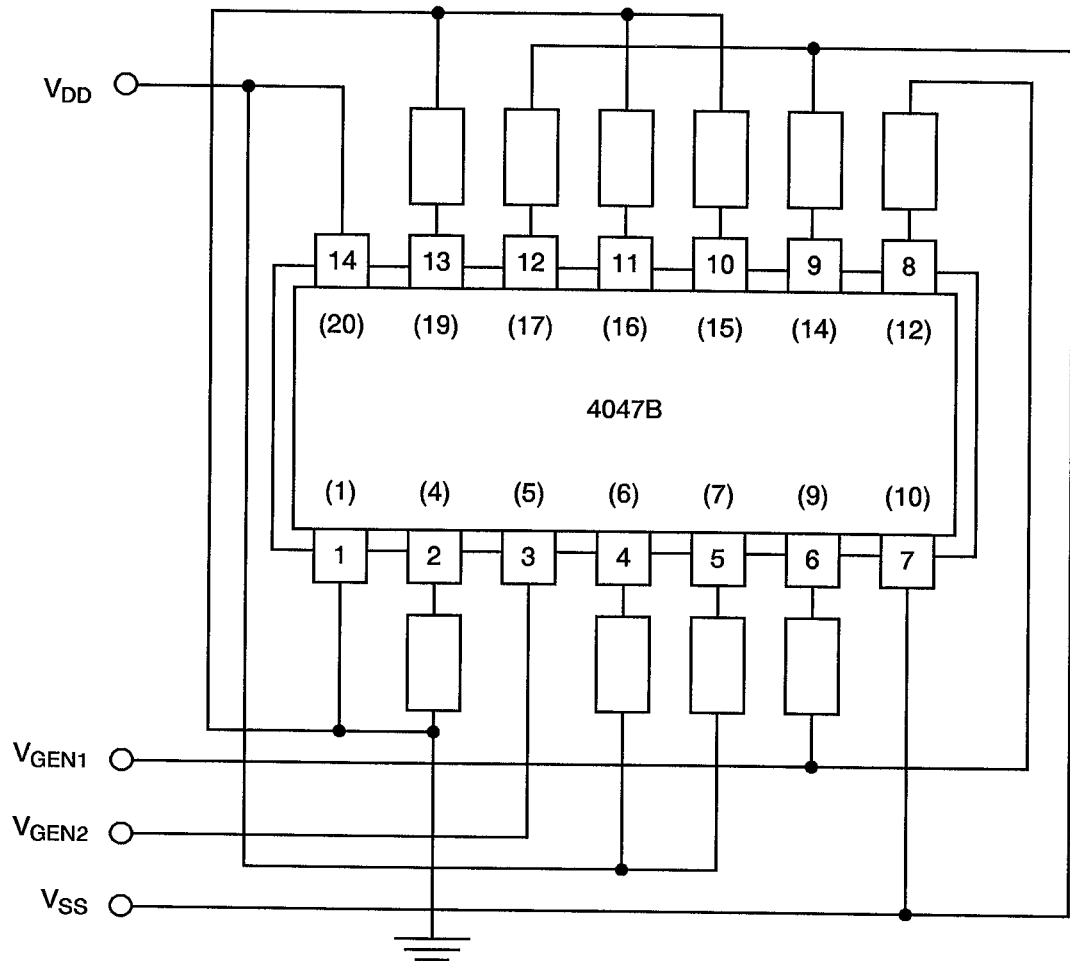
FIGURE 5(b) - ELECTRICAL CIRCUIT FOR BURN-IN HIGH TEMPERATURE REVERSE BIAS, P-CHANNELS



NOTES 1. Pin numbers in parenthesis are for the chip carrier package.



FIGURE 5(c) - ELECTRICAL CIRCUIT FOR BURN-IN DYNAMIC



NOTES

1. Pin numbers in parenthesis are for the chip carrier package.



4.8 ENVIRONMENTAL AND ENDURANCE TESTS (CHARTS IV AND V OF ESA/SCC GENERIC SPECIFICATION NO. 9000)

4.8.1 Electrical Measurements on Completion of Environmental Tests

The parameters to be measured on completion of environmental tests are scheduled in Table 6. Unless otherwise stated, the measurements shall be performed at $T_{amb} = +22 \pm 3$ °C.

4.8.2 Electrical Measurements at Intermediate Points during Endurance Tests

The parameters to be measured at intermediate points during endurance tests are as scheduled in Table 6 of this specification.

4.8.3 Electrical Measurements on Completion of Endurance Tests

The parameters to be measured on completion of endurance testing are as scheduled in Table 6 of this specification. Unless otherwise stated, the measurements shall be performed at $T_{amb} = +22 \pm 3$ °C.

4.8.4 Conditions for Operating Life Test

The requirements for operating life testing are specified in Section 9 of ESA/SCC Generic Specification No. 9000. The conditions for operating life testing shall be as specified in Table 5(c) of this specification.

4.8.5 Electrical Circuits for Operating Life Tests

Circuits for use in performing the operating life tests are shown in Figure 5(c) of this specification.

4.8.6 Conditions for High Temperature Storage Test

The requirements for the high temperature storage test are specified in ESA/SCC Generic Specification No. 9000. The temperature to be applied shall be the maximum storage temperature specified in Table 1(b) of this specification.



TABLE 6 - ELECTRICAL MEASUREMENTS ON COMPLETION OF ENVIRONMENTAL TESTS AND AT INTERMEDIATE POINTS AND ON COMPLETION OF ENDURANCE TESTING

NO.	CHARACTERISTICS	SYMBOL	SPEC. AND/OR TEST METHOD	TEST CONDITIONS	CHANGE LIMITS (Δ)			UNIT
						MIN	MAX	
1	Functional Test	-	As per Table 2	As per Table 2	-	-	-	-
3 to 12	Quiescent Current	I_{DD}	As per Table 2	As per Table 2	± 75	-	-	nA
13 to 18	Input Current Low Level	I_{IL}	As per Table 2	As per Table 2	-	-	-50	nA
19 to 24	Input Current High Level	I_{IH}	As per Table 2	As per Table 2	-	-	50	nA
25 to 27	Output Voltage Low Level	V_{OL}	As per Table 2	As per Table 2	-	-	0.05	V
28 to 30	Output Voltage High Level	V_{OH}	As per Table 2	As per Table 2	14.95	-	-	V
31 to 33	Output Drive Current N-Channel	I_{OL1}	As per Table 2	As per Table 2	± 15 (1)	-	-	%
34 to 36	Output Drive Current N-Channel	I_{OL2}	As per Table 2	As per Table 2	± 15 (1)	-	-	%
37 to 39	Output Drive Current P-Channel	I_{OH1}	As per Table 2	As per Table 2	± 15 (1)	-	-	%
40 to 42	Output Drive Current P-Channel	I_{OH2}	As per Table 2	As per Table 2	± 15 (1)	-	-	%
43	Input Voltage Low Level (Noise Immunity) (Functional Test)	V_{IL1}	As per Table 2	As per Table 2	-	4.5	-	V
	Input Voltage High Level (Noise Immunity) (Functional Test)	V_{IH1}			-	-	0.5	
45	Threshold Voltage N-Channel	V_{THN}	As per Table 2	As per Table 2	± 0.3	-	-	V
46	Threshold Voltage P-Channel	V_{THP}	As per Table 2	As per Table 2	± 0.3	-	-	V

NOTES 1. Percentage of limit value if voltage is the measurement function.

**SCC**ESA/SCC Detail Specification
No. 9207/003

PAGE 46

ISSUE 3

APPENDIX 'A'Page 1 of 1**AGREED DEVIATIONS FOR STMICROELECTRONICS (F)**

ITEMS AFFECTED	DESCRIPTION OF DEVIATION
Para. 4.2.3	Para. 9.23, High Temperature Reverse Bias Burn-in: The temperature limits of MIL-STD-883, Para. 4.5.8(c) may be used. Para. 9.24, Power Burn-in: The temperature limits of MIL-STD-883, Para. 4.5.8(c) may be used.
Para. 4.2.4	Para. 9.21.1, Operating Life during Qualification Testing: The temperature limits of MIL-STD-883, Para. 4.5.8(c) may be used.
Para. 4.2.5	Para. 9.21.2, Operating Life during Lot Acceptance Testing: The temperature limits of MIL-STD-883, Para. 4.5.8(c) may be used.