



**INTEGRATED CIRCUITS, SILICON MONOLITHIC,
CMOS QUAD 2-INPUT AND GATE,
BASED ON TYPE 4081B**

ESCC Detail Specification No. 9201/052

**ISSUE 1
October 2002**



	ESCC Detail Specification		PAGE ii ISSUE 1
--	---------------------------	--	--------------------

LEGAL DISCLAIMER AND COPYRIGHT

European Space Agency, Copyright © 2002. All rights reserved.

The European Space Agency disclaims any liability or responsibility, to any person or entity, with respect to any loss or damage caused, or alleged to be caused, directly or indirectly by the use and application of this ESCC publication.

This publication, without the prior permission of the European Space Agency and provided that it is not used for a commercial purpose, may be:

- copied in whole in any medium without alteration or modification.
- copied in part, in any medium, provided that the ESCC document identification, comprising the ESCC symbol, document number and document issue, is removed.



europaean space agency
agence spatiale européenne

Pages 1 to 42

**INTEGRATED CIRCUITS, SILICON MONOLITHIC,
CMOS QUAD 2-INPUT AND GATE,
BASED ON TYPE 4081B**

ESA/SCC Detail Specification No. 9201/052

SCC

**space components
coordination group**

Issue/Rev.	Date	Approved by	
		SCCG Chairman	ESA Director General or his Deputy
Issue 4	March 1992		
Revision 'A'	October 1994		
Revision 'B'	May 2000		
Revision 'C'	May 2001		



DOCUMENTATION CHANGE NOTICE

Rev. Letter	Rev. Date	Reference	CHANGE Item	Approved DCR No.
		This Issue supersedes Issue 3 and incorporates all modifications defined in the following DCR's:-		
		Cover Page		None
		DCN		None
		Para. 1.10	: Last sentence rewritten to include ESD Class and Minimum Critical Path Failure Voltage	23385
		Table 1(a)	: Table amended : Lead Material and/or Finish amended	22398 23465
		Figure 2(a)	: Table corrected	23247
		Figure 2(b)	: "CKT A" deleted from title	22398
		Figure 2(c)	: Figure deleted in toto	22398
		Figure 2(d)	: Title amended to "2(c)" : Table corrected	22398 23247
		Notes to Figures	: In Title and Note 1, 2(d) amended to "2(c)"	22398
		Figure 3(a)	: Gate configuration deleted from inside DIL/FP outline	23516
		Figure 3(b)	: "(Each Gate)" added to Title : Note 2 standardised	23516 23516
		Figures 3(c),(d),(e)	: Circuit A heading and Circuit B heading and drawing deleted	23516 22398
		Para. 4.2.2	: Deviation deleted, "None" added	21048
		Para. 4.2.4	: Deviation deleted, "None" added	22919
		Para. 4.2.5	: Deviation deleted, "None" added	22919
		Para. 4.4.2	: Material Type and Finishes amended	23465
		Para. 4.5.2	: Third sentence amended to read :...2(c)."	22398
		Table 2	: Nos. 85 to 92, Limits column amended : Nos. 93 to 100, "CKT A" deleted from first measurement and "CKT B" entry deleted in toto	22398 22398
		Figures 4(i), (j)	: Note corrected to read "Each output..."	23516
		Figure 4(k)	: "B Input" added to Grounded connection	23516
		Figures 4(n), (p)	: Circuit A heading and Circuit B heading and drawing deleted	22398
'A'	Oct. '94	P1. Cover Page		None
		P2. DCN		None
		P6. Table 1(a)	: Lead Material and/or Finish amended	221049
		P8. Figure 2(b)	: Drawing altered : Dimension F (Max) amended	23540 23540
		P10. Notes	: Note 7 added	23540
		P14. Para. 4.3.2	: Weights amended	23539
		Para. 4.4.2	: Lead Finish, Types amended	221049
'B'	May '00	P1. Cover Page		None
		P2. DCN		None
		P6. Table 1(a)	: Variants 08 and 09 added	221567
		P7. Figure 2(a)	: Side elevation amended : Dimension 'C' amended	221567 221567
		P9. Figure 2(c)	: In the drawing, Pin No. 20 location corrected	221550
		P10. Notes to Figures	: Title amended	221567
		P10A. Figure 2(d)	: New page added	221567
		P11. Figure 3(a)	: Left-hand Title amended : "SO" added to comparison Titles	221567 221567
		P14. Para. 4.3.2	: SO package added to text	221567
		Para. 4.4.2	: SO package added to text	221567
		Para. 4.5.2	: SO package added to text	221567
'C'	May '01	P1. Cover page	: Page count incremented by 1	221602
		P2. DCN		None
		P2A. DCN	: Page added	None



SCC

ESA/SCC Detail Specification
No. 9201/052

Rev.'C'

PAGE 2A
ISSUE 4

DOCUMENTATION CHANGE NOTICE

Rev. Letter	Rev. Date	Reference	CHANGE Item	Approved DCR No.
		P4. T of C	: Appendices entry amended	221602
		P5. Para. 1.3	: New sentence added	221602
		P6. Table 1(b)	: No. 8, Maximum temperature amended	221602
		P40. Para. 4.8.6	: Last sentence deleted, new text added	221602
		P42. Appendix 'A'	: Appendix added	221602

**TABLE OF CONTENTS**

	<u>Page</u>
1. <u>GENERAL</u>	5
1.1 Scope	5
1.2 Component Type Variants	5
1.3 Maximum Ratings	5
1.4 Parameter Derating Information	5
1.5 Physical Dimensions	5
1.6 Pin Assignment	5
1.7 Truth Table	5
1.8 Circuit Schematic	5
1.9 Functional Diagram	5
1.10 Handling Precautions	5
1.11 Input Protection Network	5
2. <u>APPLICABLE DOCUMENTS</u>	13
3. <u>TERMS, DEFINITIONS, ABBREVIATIONS, SYMBOLS AND UNITS</u>	13
4. <u>REQUIREMENTS</u>	13
4.1 General	13
4.2 Deviations from Generic Specification	13
4.2.1 Deviations from Special In-process Controls	13
4.2.2 Deviations from Final Production Tests	13
4.2.3 Deviations from Burn-in Tests	13
4.2.4 Deviations from Qualification, Environmental and Endurance Tests	13
4.2.5 Deviations from Lot Acceptance Tests	14
4.3 Mechanical Requirements	14
4.3.1 Dimension Check	14
4.3.2 Weight	14
4.4 Materials and Finishes	14
4.4.1 Case	14
4.4.2 Lead Material and Finish	14
4.5 Marking	14
4.5.1 General	14
4.5.2 Lead Identification	14
4.5.3 The SCC Component Number	15
4.5.4 Traceability Information	15
4.6 Electrical Measurements	15
4.6.1 Electrical Measurements at Room Temperature	15
4.6.2 Electrical Measurements at High and Low Temperatures	15
4.6.3 Circuits for Electrical Measurements	15
4.7 Burn-in Tests	15
4.7.1 Parameter Drift Values	15
4.7.2 Conditions for H.T.R.B. and Burn-in	15
4.7.3 Electrical Circuits for H.T.R.B. and Burn-in	15
4.8 Environmental and Endurance Tests	40
4.8.1 Electrical Measurements on Completion of Environmental Tests	40
4.8.2 Electrical Measurements at Intermediate Points during Endurance Tests	40
4.8.3 Electrical Measurements on Completion of Endurance Tests	40
4.8.4 Conditions for Operating Life Test	40
4.8.5 Electrical Circuits for Operating Life Tests	40
4.8.6 Conditions for High Temperature Storage Test	40

**TABLES**

	<u>Page</u>
1(a) Type Variants	6
1(b) Maximum Ratings	6
2 Electrical Measurements at Room Temperature, d.c. Parameters	16
Electrical Measurements at Room Temperature, a.c. Parameters	20
3(a) Electrical Measurements at High Temperature	21
3(b) Electrical Measurements at Low Temperature	25
4 Parameter Drift Values	35
5(a) Conditions for Burn-in High Temperature Reverse Bias, N-Channels	36
5(b) Conditions for Burn-in High Temperature Reverse Bias, P-Channels	36
5(c) Conditions for Burn-in Dynamic	37
6 Electrical Measurements on Completion of Environmental Tests and at Intermediate Points and on Completion of Endurance Testing	41

FIGURES

1 Not applicable	
2 Physical Dimensions	7
3(a) Pin Assignment	11
3(b) Truth Table	11
3(c) Circuit Schematic	12
3(d) Functional Diagram	12
3(e) Input Protection Network	12
4 Circuits for Electrical Measurements	29
5(a) Electrical Circuit for Burn-in High Temperature Reverse Bias, N-Channels	38
5(b) Electrical Circuit for Burn-in High Temperature Reverse Bias, P-Channels	38
5(c) Electrical Circuit for Burn-in Dynamic	39

APPENDICES (Applicable to specific Manufacturers only)

'A' Agreed Deviations for STMicroelectronics (F)	42
--	----

**1. GENERAL****1.1 SCOPE**

This specification details the ratings, physical and electrical characteristics, test and inspection data for a silicon monolithic, CMOS Quad 2-Input AND Gate, having fully buffered outputs, based on Type 4081B. It shall be read in conjunction with ESA/SCC Generic Specification No. 9000, the requirements of which are supplemented herein.

1.2 COMPONENT TYPE VARIANTS

Variants of the basic type integrated circuits specified herein, which are also covered by this specification, are given in Table 1(a).

1.3 MAXIMUM RATINGS

The maximum ratings, which shall not be exceeded at any time during use or storage, applicable to the integrated circuits specified herein, are as scheduled in Table 1(b).

Maximum ratings shall only be exceeded during testing to the extent specified in this specification and when stipulated in Test Methods and Procedures of the applicable ESA/SCC Generic Specification.

1.4 PARAMETER DERATING INFORMATION (FIGURE 1)

Not applicable.

1.5 PHYSICAL DIMENSIONS

The physical dimensions of the integrated circuits specified herein are shown in Figure 2.

1.6 PIN ASSIGNMENT

As per Figure 3(a).

1.7 TRUTH TABLE

As per Figure 3(b).

1.8 CIRCUIT SCHEMATIC

As per Figure 3(c).

1.9 FUNCTIONAL DIAGRAM

As per Figure 3(d).

1.10 HANDLING PRECAUTIONS

These devices are susceptible to damage by electrostatic discharge. Therefore, suitable precautions shall be employed for protection during all phases of manufacture, testing, packaging, shipment and any handling. These components are Catagorised as Class 1 with a Minimum Critical Path Failure Voltage of 400Volts.

1.11 INPUT PROTECTION NETWORK

Double diode protection shall be incorporated into each input as shown in Figure 3(e).

**TABLE 1(a) - TYPE VARIANTS**

VARIANT	CASE	FIGURE	LEAD MATERIAL AND/OR FINISH
01	FLAT	2(a)	G2 or G8
02	FLAT	2(a)	G4
03	D.I.L.	2(b)	G2 or G8
04	D.I.L.	2(b)	G4
07	CHIP CARRIER	2(c)	2
08	SO CERAMIC	2(d)	G2
09	SO CERAMIC	2(d)	G4

TABLE 1(b) - MAXIMUM RATINGS

NO.	CHARACTERISTICS	SYMBOL	MAXIMUM RATINGS	UNIT	REMARKS
1	Supply Voltage	V_{DD}	-0.5 to + 18	V	Note 1
2	Input Voltage	V_{IN}	-0.5 to $V_{DD} + 0.5$	V	Note 2 Power on
3	D.C. Input Current	$\pm I_{IN}$	10	mA	-
4	D.C. Output Current	$\pm I_O$	10	mA	Note 3
5	Device Dissipation	P_D	200	mWdc	Per Package
6	Output Dissipation	P_{DSO}	100	mWdc	Note 4
7	Operating Temperature Range	T_{op}	-55 to + 125	°C	-
8	Storage Temperature Range	T_{stg}	-65 to + 150	°C	-
9	Soldering Temperature for FP and DIP for CCP	T_{sol}	+ 300 + 245	°C	Note 5 Note 6

NOTES

- Device is functional from +3V to +15V with reference to V_{SS} .
- $V_{DD} + 0.5V$ should not exceed +18V.
- The maximum output current of any single output.
- The maximum power dissipation of any single output.
- Duration 10 seconds maximum at a distance of not less than 1.5mm from the device body and the same lead shall not be resoldered until 3 minutes have elapsed.
- Duration 30 seconds maximum and the same terminal shall not be resoldered until 3 minutes have elapsed.



FIGURE 2 - PHYSICAL DIMENSIONS

FIGURE 2(a) - FLAT PACKAGE, 14-Pin

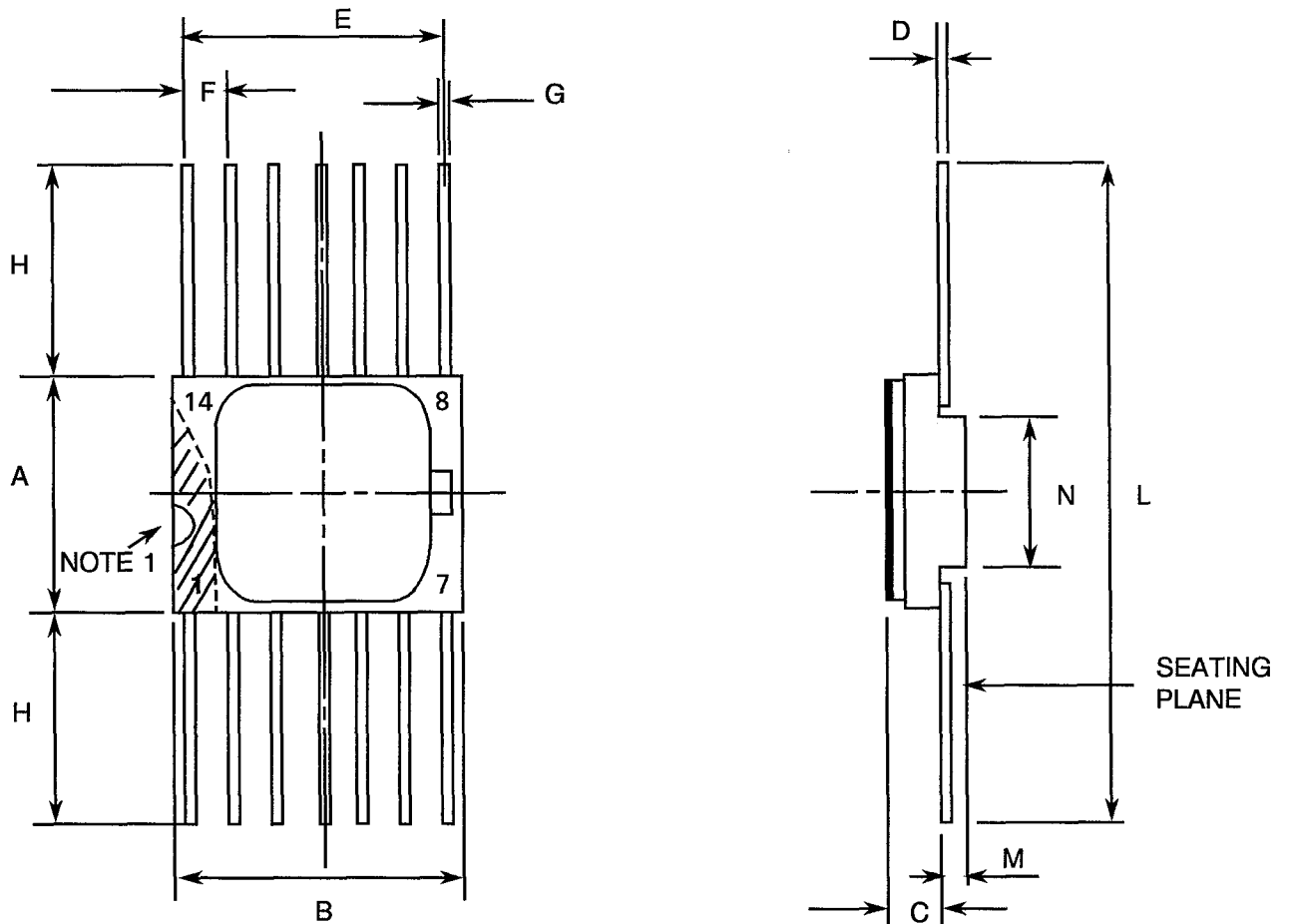

SYMBOL	MILLIMETRES		NOTES
	MIN	MAX	
A	6.75	7.06	
B	9.76	10.14	
C	1.49	1.95	
D	0.102	0.152	3
E	7.50	7.75	
F	1.27	TYPICAL	4
G	0.38	0.48	3
H	6.0	-	3
L	18.75	22.0	
M	0.33	0.43	
N	4.31	TYPICAL	

NOTES: See Page 10.



FIGURE 2 - PHYSICAL DIMENSIONS (CONTINUED)

FIGURE 2(b) - DUAL-IN-LINE PACKAGE, 14-PIN

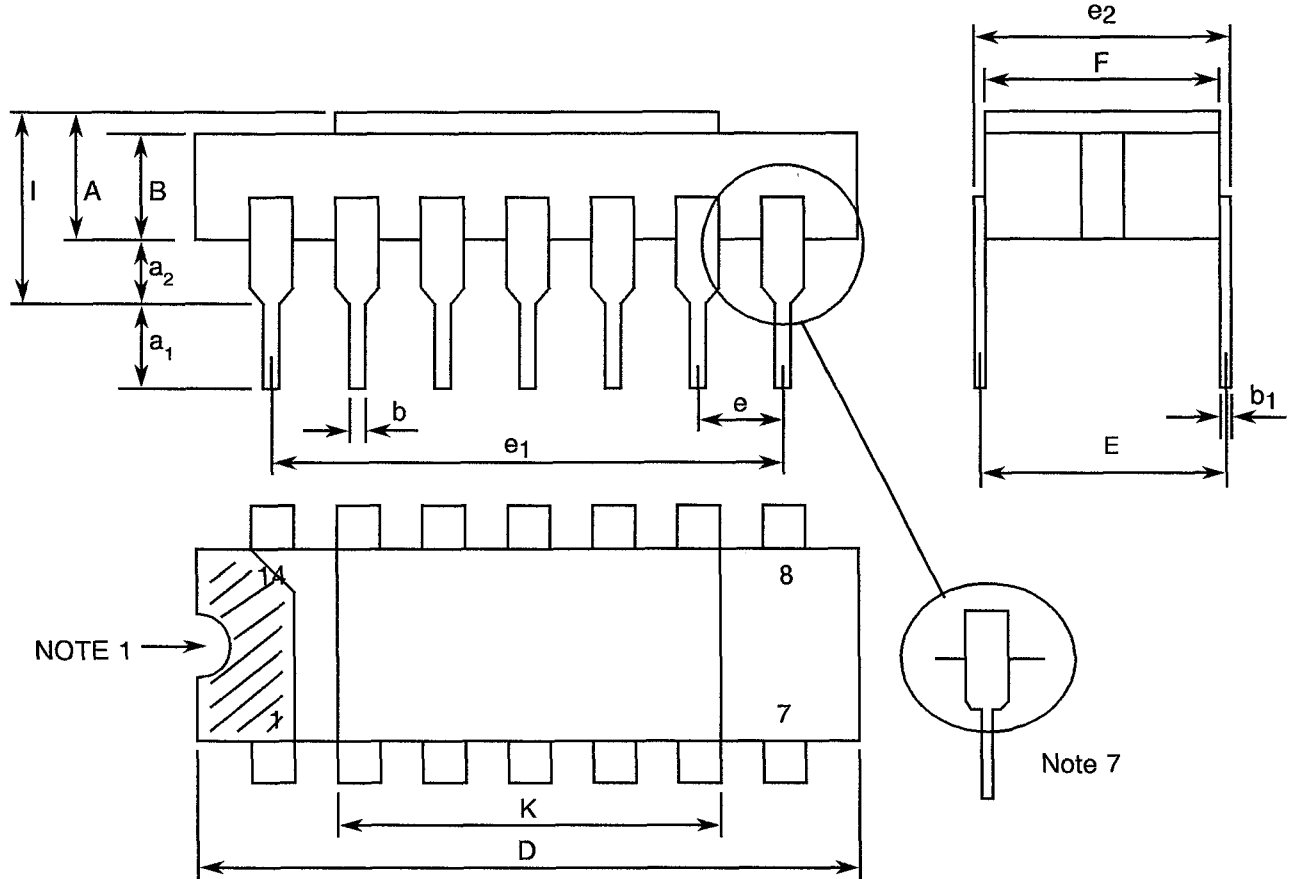

SYMBOL	MILLIMETRES		NOTES
	MIN	MAX	
A	2.10	2.54	
a ₁	3.0	3.7	
a ₂	0.63	1.14	2
B	1.82	2.23	
b	0.40	0.50	3
b ₁	0.20	0.30	3
D	18.79	19.20	
E	7.36	7.87	
e	2.29	2.79	4
e ₁	15.11	15.37	
e ₂	7.62	8.12	
F	7.11	7.75	
l	-	3.70	
K	10.90	12.10	

NOTES: See Page 10.



FIGURE 2 - PHYSICAL DIMENSIONS (CONTINUED)

FIGURE 2(c) - CHIP CARRIER - 20-TERMINAL

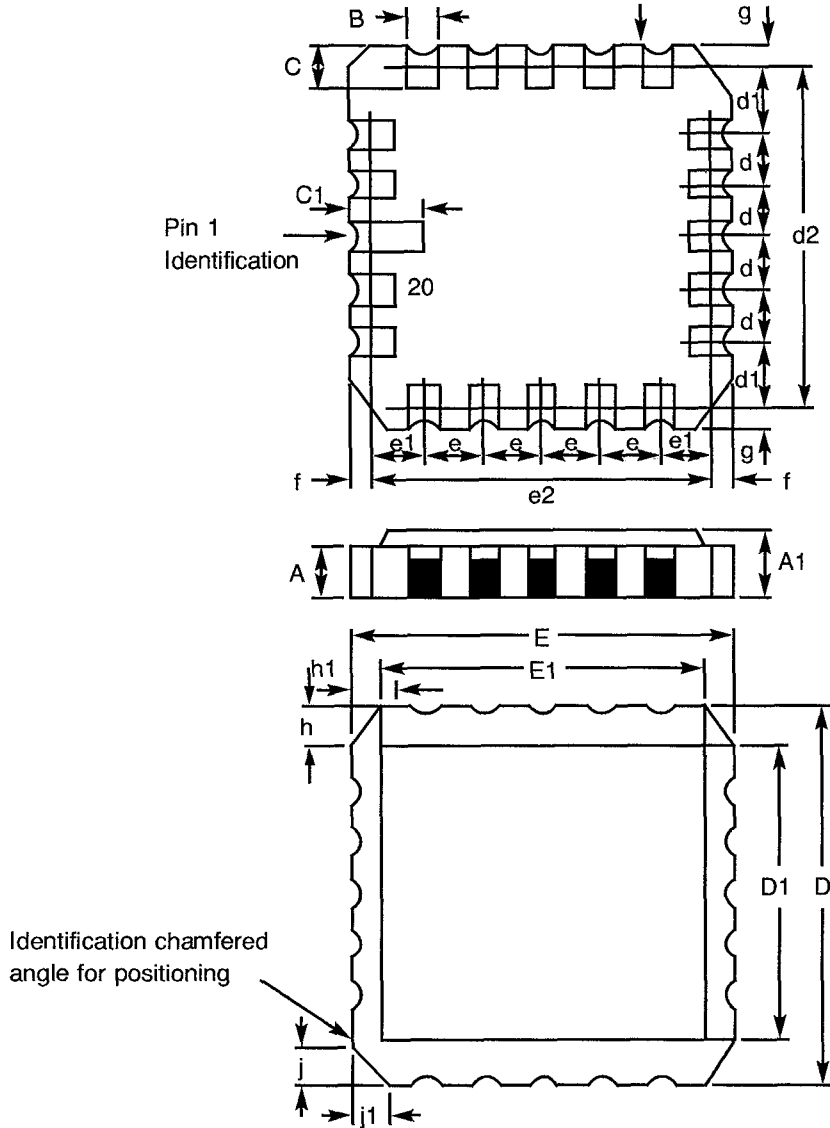

DIMENSIONS	MILLIMETRES		NOTES
	MIN	MAX	
A	1.14	1.95	
A1	1.63	2.36	
B	0.55	0.72	3
C	1.06	1.47	3
C ₁	1.91	2.41	
D	8.67	9.09	
D1	7.21	7.52	
d, d1	1.27	TYPICAL	4
d2	7.62	TYPICAL	
E	8.67	9.09	
E1	7.21	7.52	
e, e1	1.27	TYPICAL	4
e2	7.62	TYPICAL	
f, g	-	0.76	
h, h1	1.01	TYPICAL	6
j, j1	0.51	TYPICAL	5

NOTES: See Page 10.

**SCC**ESA/SCC Detail Specification
No. 9201/052

Rev. 'B'

PAGE 10

ISSUE 4

FIGURE 2 - PHYSICAL DIMENSIONS (CONTINUED)**NOTES TO FIGURES 2(a) TO 2(d) INCLUSIVE**

1. Index area; a notch, letter or dot shall be located adjacent to Pin 1 and shall be within the shaded area shown. For chip carrier packages the index shall be as defined in Figure 2(c).
2. The dimension shall be measured from the seating plane to the base plane.
3. All leads or terminals.
4. Twelve spaces.
5. Index corner only.
6. Three non-index corners.
7. For all pins, either pin shape may be supplied.



FIGURE 2 - PHYSICAL DIMENSIONS (CONTINUED)

FIGURE 2(d) - SMALL OUTLINE CERAMIC PACKAGE, 14-PIN

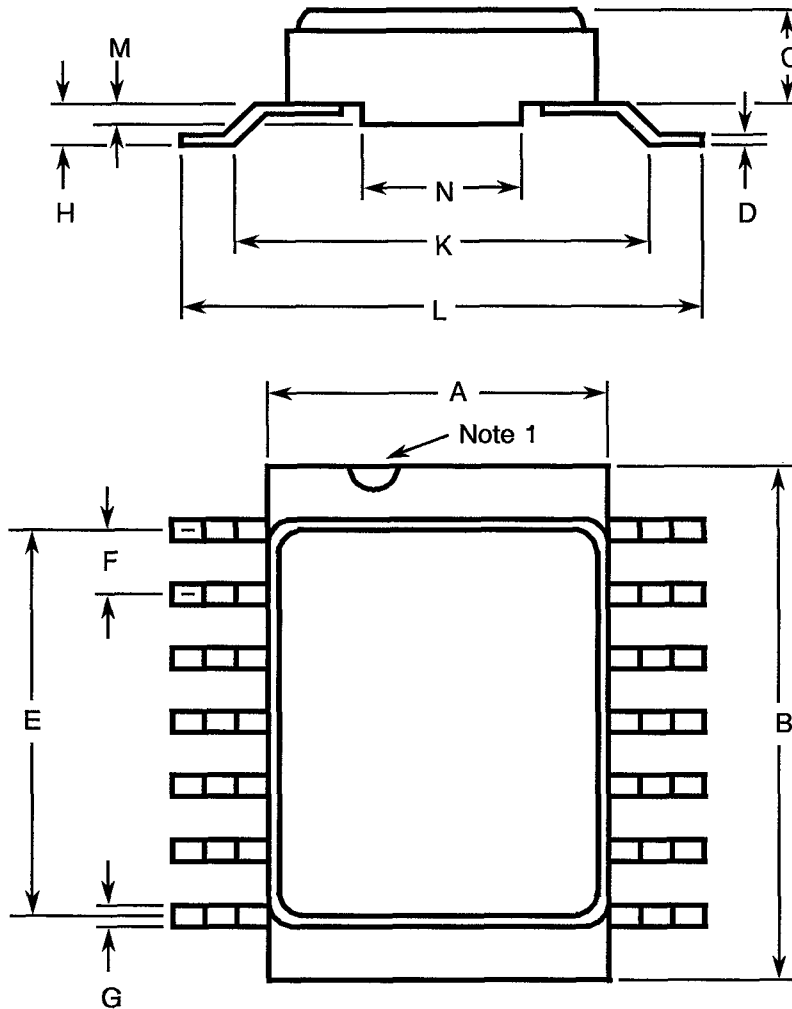

SYMBOL	MILLIMETRES		NOTES
	MIN.	MAX.	
A	6.75	7.06	
B	9.76	10.14	
C	1.49	1.95	
D	0.102	0.152	3
E	7.50	7.75	
F	1.27 TYPICAL		4
G	0.38	0.48	3
H	0.60	0.90	3
K	9.00 TYPICAL		
L	10	10.65	
M	0.33	0.43	
N	4.31 TYPICAL		

NOTES: See Page 10.



FIGURE 3(a) - PIN ASSIGNMENT

DUAL-IN-LINE, SO AND FLAT PACKAGES

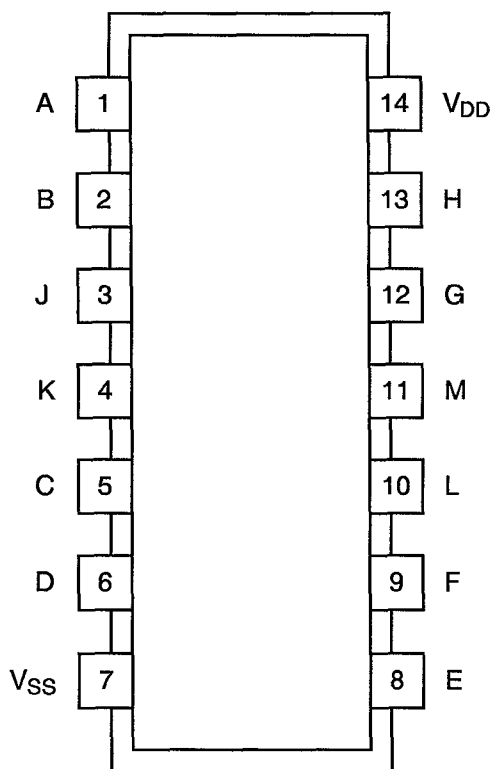

TOP VIEW

CHIP CARRIER PACKAGE

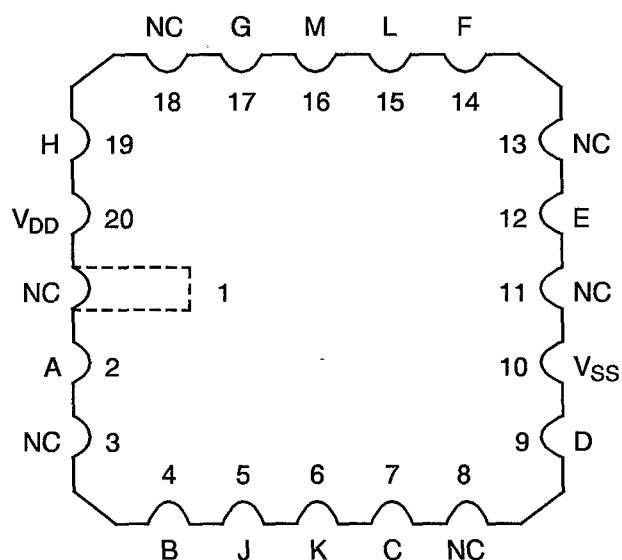

TOP VIEW

FLAT PACKAGE, SO AND DUAL-IN-LINE TO CHIP CARRIER PIN ASSIGNMENT

FLAT PACKAGE, SO AND DUAL-IN-LINE PIN OUTS	1	2	3	4	5	6	7	8	9	10	11	12	13	14
CHIP CARRIER PIN OUTS	2	4	5	6	7	9	10	12	14	15	16	17	19	20

FIGURE 3(b) - TRUTH TABLE(EACH GATE)

INPUT		OUTPUT
A	B	Y
L	L	L
H	L	L
L	H	L
H	H	H

NOTES

1. Positive Logic $Y = A.B$.
2. Logic Level Definitions: L = Low Level, H = High Level.



FIGURE 3(c) - CIRCUIT SCHEMATIC (EACH GATE)

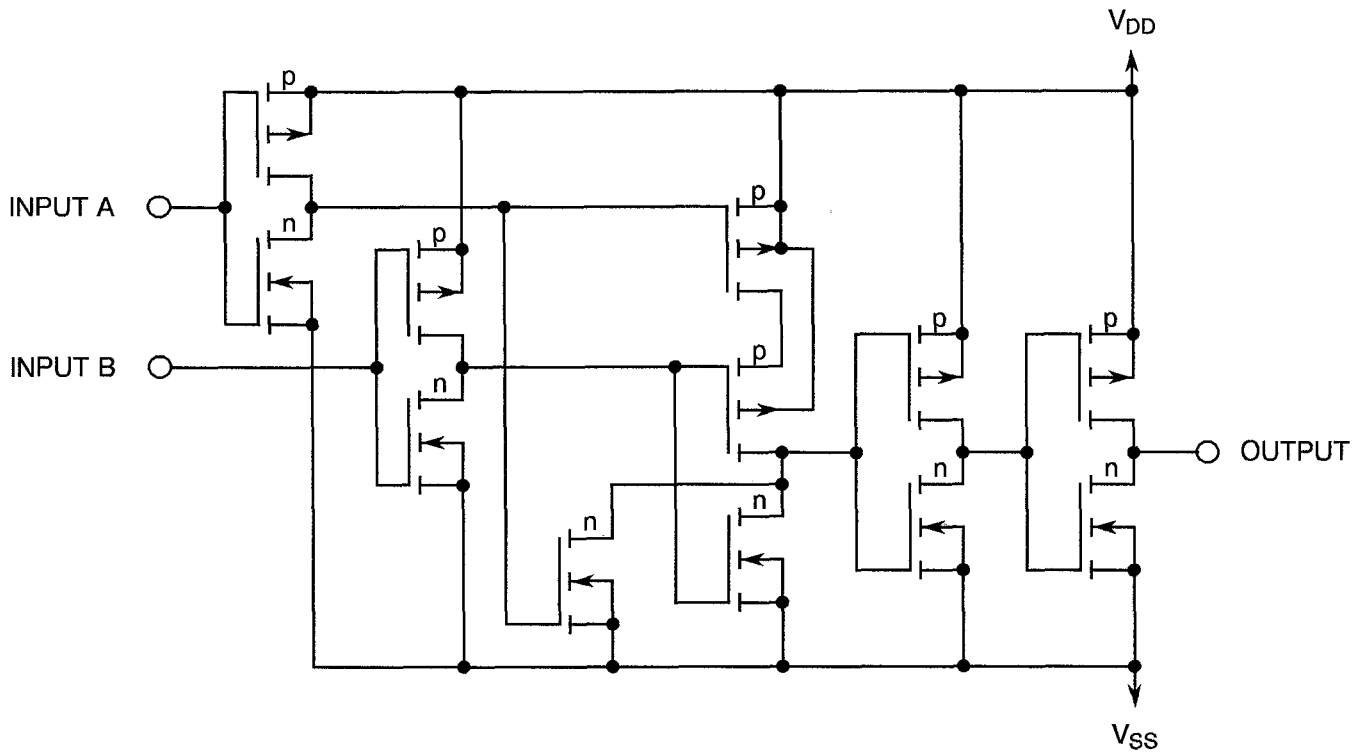
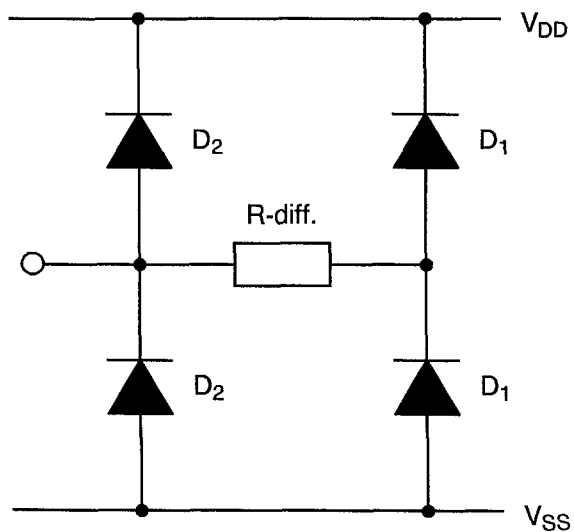

FIGURE 3(d) - FUNCTIONAL DIAGRAM (EACH GATE)



FIGURE 3(e) - INPUT PROTECTION NETWORK



**2. APPLICABLE DOCUMENTS**

The following documents form part of this specification and shall be read in conjunction with it:-

- (a) ESA/SCC Generic Specification No. 9000 for Integrated Circuits.
- (b) MIL-STD-883, Test Methods and Procedures for Micro-electronics.

3. TERMS, DEFINITIONS, ABBREVIATIONS, SYMBOLS AND UNITS

For the purpose of this specification, the terms, definitions, abbreviations, symbols and units specified in ESA/SCC Basic Specification No. 21300 shall apply. In addition, the following abbreviations are used:

- V_{IC} - Input Clamp Voltage
- P_{DSO} - Single Output Power Dissipation
- CKT - Circuit

4. REQUIREMENTS**4.1 GENERAL**

The complete requirements for procurement of the integrated circuits specified herein shall be as stated in this specification and ESA/SCC Generic Specification No. 9000 for Integrated Circuits. Deviations from the Generic Specification, applicable to this specification only, are listed in Para. 4.2.

Deviations from the applicable Generic Specification and this Detail Specification, formally agreed with specific Manufacturers on the basis that the alternative requirements are equivalent to the ESA/SCC requirement and do not affect the components' reliability, are listed in the appendices attached to this specification.

4.2 DEVIATIONS FROM GENERIC SPECIFICATION**4.2.1 Deviations from Special In-process Controls**

None.

4.2.2 Deviations from Final Production Tests (Chart II)

None.

4.2.3 Deviations from Burn-in Tests (Chart III)**4.2.3.1 Deviations from High Temperature Reverse Bias (H.T.R.B.)**

Prior to operating power burn-in, a high temperature reverse bias (H.T.R.B.) screen at +125°C shall be added for the N-Channel and then for the P-Channel in accordance with Tables 5(a) and 5(b) of this specification. Each exposure to H.T.R.B. shall be 72 hours and Table 4 Parameter Drift Values shall be applied at 0 and 144 hours.

4.2.4 Deviations from Qualification, Environmental and Endurance Tests (Chart IV)

None.



4.2.5 Deviations from Lot Acceptance Tests (Chart V)

None.

4.3 MECHANICAL REQUIREMENTS

4.3.1 Dimension Check

The dimensions of the integrated circuits specified herein shall be checked. They shall conform to those shown in Figure 2.

4.3.2 Weight

The maximum weight of the integrated circuits specified herein shall be 1.34 grammes for the dual-in-line package, 0.58 grammes for the flat and SO packages, and 0.52 grammes for the chip carrier package.

4.4 MATERIALS AND FINISHES

The materials and finishes shall be as specified herein. Where a definite material is not specified, a material which will enable the integrated circuits specified herein to meet the performance requirements of this specification shall be used. Acceptance or approval of any constituent material does not guarantee acceptance of the finished product.

4.4.1 Case

The case shall be hermetically sealed and have a metal body with hard glass seals or a ceramic body and the lids shall be welded, brazed or preform-soldered.

4.4.2 Lead Material and Finish

For dual-in-line and flat packages, the material shall be Type 'G' with either Type '4' or Type '2 or 8' finish in accordance with ESA/SCC Basic Specification No. 23500. For chip carrier packages the finish shall be Type '2' in accordance with ESA/SCC Basic Specification No. 23500. For SO ceramic packages, the material shall be Type 'G' with either Type '2' or Type '4' finish in accordance with ESA/SCC Basic Specification No. 23500. (See Table 1(a) for Type Variants).

4.5 MARKING

4.5.1 General

The marking of all components delivered to this specification shall be in accordance with the requirements of ESA/SCC Basic Specification No. 21700. Each component shall be marked in respect of:-

- (a) Lead Identification.
- (b) The SCC Component Number.
- (c) Traceability Information.

4.5.2 Lead Identification

For dual-in-line, flat and SO packages, an index shall be located at the top of the package in the position defined in Note 1 to Figure 2 or, alternatively, a tab may be used to identify Pin No. 1. The pin numbering must be read with the index or tab on the left-hand side. For chip carrier packages, the index shall be as defined by Figure 2(c).



4.5.3 The SCC Component Number

Each component shall bear the SCC Component Number which shall be constituted and marked as follows:

920105201B

Detail Specification Number _____

Type Variant, as applicable _____

Testing Level (B or C, as appropriate) _____

4.5.4 Traceability Information

Each component shall be marked in respect of traceability information in accordance with the requirements of ESA/SCC Basic Specification No. 21700.

4.6 ELECTRICAL MEASUREMENTS

4.6.1 Electrical Measurements at Room Temperature

The parameters to be measured in respect of electrical characteristics are scheduled in Table 2. Unless otherwise specified, the measurements shall be performed at $T_{amb} = +22 \pm 3$ °C.

4.6.2 Electrical Measurements at High and Low Temperatures

The parameters to be measured at high and low temperatures are scheduled in Table 3. The measurements shall be performed at $T_{amb} = +125(+0-5)$ °C and $-55(+5-0)$ °C respectively.

4.6.3 Circuits for Electrical Measurements

Circuits and functional test sequence for use in performing electrical measurements listed in Tables 2 and 3 of this specification are shown in Figure 4.

4.7 BURN-IN TESTS

4.7.1 Parameter Drift Values

The parameter drift values applicable to burn-in are specified in Table 4 of this specification. Unless otherwise stated, measurements shall be performed at $+22 \pm 3$ °C. The parameter drift values (Δ) applicable to the parameters scheduled, shall not be exceeded. In addition to these drift value requirements, the appropriate limit value specified for a given parameter in Table 2 shall not be exceeded.

4.7.2 Conditions for H.T.R.B. and Burn-in

The requirements for H.T.R.B. and Burn-in are specified in Section 7 of ESA/SCC Generic Specification No. 9000. The conditions for H.T.R.B. and Burn-in shall be as specified in Tables 5(a), 5(b) and 5(c) of this specification.

4.7.3 Electrical Circuits for H.T.R.B. and Burn-in

Circuits for use in performing the H.T.R.B. and Burn-in tests are shown in Figures 5(a), 5(b) and 5(c) of this specification.

**TABLE 2 - ELECTRICAL MEASUREMENTS AT ROOM TEMPERATURE - d.c. PARAMETERS**

NO.	CHARACTERISTICS	SYMBOL	TEST METHOD MIL-STD 883	TEST FIG.	TEST CONDITIONS (PINS UNDER TEST D/F = DIP AND FP C = CCP)	LIMITS		UNIT
						MIN	MAX	
1	Functional Test	-	-	4(a)	Verify Truth Table without Load. $V_{DD} = 3V_{dc}$, $V_{SS} = 0V_{dc}$ Notes 1 and 2	-	-	-
2	Functional Test	-	-	4(a)	Verify Truth Table without Load. $V_{DD} = 15V_{dc}$, $V_{SS} = 0V_{dc}$ Notes 1 and 2	-	-	-
3 to 6	Quiescent Current	I_{DD}	3005	4(b)	$V_{IL} = 0V_{dc}$, $V_{IH} = 15V_{dc}$ $V_{DD} = 15V_{dc}$, $V_{SS} = 0V_{dc}$ Note 3 (Pin D/F 14) (Pin C 20)	-	100	nA
7 to 14	Input Current Low Level	I_{IL}	3009	4(c)	V_{IN} (Under Test) = $0V_{dc}$ V_{IN} (Remaining Inputs) = $15V_{dc}$ $V_{DD} = 15V_{dc}$, $V_{SS} = 0V_{dc}$ (Pins D/F 1-2-5-6-8-9-12-13) (Pins C 2-4-7-9-12-14-17-19)	-	-50	nA
15 to 22	Input Current High Level	I_{IH}	3010	4(d)	V_{IN} (Under Test) = $15V_{dc}$ V_{IN} (Remaining Inputs) = $0V_{dc}$ $V_{DD} = 15V_{dc}$, $V_{SS} = 0V_{dc}$ (Pins D/F 1-2-5-6-8-9-12-13) (Pins C 2-4-7-9-12-14-17-19)	-	50	nA
23 to 30	Output Voltage Low Level	V_{OL}	3007	4(e)	Gate Under Test: $V_{IN1} = 15V_{dc}$, $V_{IN2} = 0V_{dc}$ ($V_{IN1} = 0V_{dc}$, $V_{IN2} = 15V_{dc}$) All Other Gates: $V_{IN} = 0V_{dc}$ $V_{OUT} = \text{Open}$ $V_{DD} = 15V_{dc}$, $V_{SS} = 0V_{dc}$ (Pins D/F 3-4-10-11) (Pins C 5-6-15-16)	-	0.05	V

NOTES: See Page 19.



TABLE 2 - ELECTRICAL MEASUREMENTS AT ROOM TEMPERATURE - d.c. PARAMETERS (CONT'D)

NO.	CHARACTERISTICS	SYMBOL	TEST METHOD MIL-STD 883	TEST FIG.	TEST CONDITIONS (PINS UNDER TEST D/F = DIP AND FP C = CCP)	LIMITS		UNIT
						MIN	MAX	
31 to 34	Output Voltage High Level	V_{OH}	3006	4(f)	Gate Under Test: $V_{IN} = 15V_{dc}$ All Other Gates: $V_{IN} = 0V_{dc}$ $V_{OUT} = \text{Open}$ $V_{DD} = 15V_{dc}$, $V_{SS} = 0V_{dc}$ (Pins D/F 3-4-10-11) (Pins C 5-6-15-16)	14.95	-	V
35 to 42	Output Drive Current N-Channel	I_{OL1}	-	4(g)	Gate Under Test: $V_{IN1} = 5V_{dc}$, $V_{IN2} = 0V_{dc}$ ($V_{IN1} = 0V_{dc}$, $V_{IN2} = 5V_{dc}$) $V_{OUT} = 0.4V_{dc}$ All Other Gates: $V_{IN} = 0V_{dc}$ $V_{DD} = 5V_{dc}$, $V_{SS} = 0V_{dc}$ Note 4 (Pins D/F 3-4-10-11) (Pins C 5-6-15-16)	0.51	-	mA
43 to 50	Output Drive Current N-Channel	I_{OL2}	-	4(g)	Gate Under Test: $V_{IN1} = 15V_{dc}$, $V_{IN2} = 0V_{dc}$ ($V_{IN1} = 0V_{dc}$, $V_{IN2} = 15V_{dc}$) $V_{OUT} = 1.5V_{dc}$ All Other Gates: $V_{IN} = 0V_{dc}$ $V_{DD} = 15V_{dc}$, $V_{SS} = 0V_{dc}$ Note 4 (Pins D/F 3-4-10-11) (Pins C 5-6-15-16)	3.4	-	mA
51 to 54	Output Drive Current P-Channel	I_{OH1}	-	4(h)	Gate Under Test: All Inputs: $V_{IL} = 5V_{dc}$ $V_{OUT} = 4.6V_{dc}$ All Other Gates: $V_{IN} = 0V_{dc}$ $V_{DD} = 5V_{dc}$, $V_{SS} = 0V_{dc}$ Note 4 (Pins D/F 3-4-10-11) (Pins C 5-6-15-16)	-0.51	-	mA

NOTES: See Page 19.

**TABLE 2 - ELECTRICAL MEASUREMENTS AT ROOM TEMPERATURE - d.c. PARAMETERS (CONT'D)**

NO.	CHARACTERISTICS	SYMBOL	TEST METHOD MIL-STD 883	TEST FIG.	TEST CONDITIONS (PINS UNDER TEST D/F = DIP AND FP C = CCP)	LIMITS		UNIT
						MIN	MAX	
55 to 58	Output Drive Current P-Channel	I_{OH2}	-	4(h)	Gate Under Test: All Inputs: $V_{IN} = 15Vdc$ $V_{OUT} = 13.5Vdc$ All Other Gates: $V_{IN} = 0Vdc$ $V_{DD} = 15Vdc, V_{SS} = 0Vdc$ Note 4 (Pins D/F 3-4-10-11) (Pins C 5-6-15-16)	-3.4	-	mA
59 to 66	Input Voltage Low Level (Noise Immunity)	V_{IL1}	-	4(i)	Gate Under Test: $V_{IN1} = 1.5Vdc,$ $V_{IN2} = 3.5Vdc$ ($V_{IN1} = 3.5Vdc,$ $V_{IN2} = 1.5Vdc$) All Other Gates: $V_{IN} = 5Vdc$ $V_{DD} = 5Vdc, V_{SS} = 0Vdc$ (Pins D/F 3-4-10-11) (Pins C 5-6-15-16)	-	0.5	V
67 to 74	Input Voltage Low Level (Noise Immunity)	V_{IL2}	-	4(i)	Gate Under Test: $V_{IN1} = 11Vdc, V_{IN2} = 4Vdc$ ($V_{IN1} = 4Vdc, V_{IN2} = 11Vdc$) All Other Gates: $V_{IN} = 15Vdc$ $V_{DD} = 15Vdc, V_{SS} = 0Vdc$ (Pins D/F 3-4-10-11) (Pins C 5-6-15-16)	-	1.5	V
75 to 78	Input Voltage High Level (Noise Immunity)	V_{IH1}	-	4(j)	Gate Under Test: All Inputs: $V_{IN} = 3.5Vdc$ All Other Gates: $V_{IN} = 0Vdc$ $V_{DD} = 5Vdc, V_{SS} = 0Vdc$ (Pins D/F 3-4-10-11) (Pins C 5-6-15-16)	4.5	-	V
79 to 82	Input Voltage High Level (Noise Immunity)	V_{IH2}	-	4(j)	Gate Under Test: All Inputs: $V_{IN} = 11Vdc$ All Other Gates: $V_{IN} = 0Vdc$ $V_{DD} = 15Vdc, V_{SS} = 0Vdc$ (Pins D/F 3-4-10-11) (Pins C 5-6-15-16)	13.5	-	V

NOTES: See Page 19.

**TABLE 2 - ELECTRICAL MEASUREMENTS AT ROOM TEMPERATURE - d.c. PARAMETERS (CONT'D)**

NO.	CHARACTERISTICS	SYMBOL	TEST METHOD MIL-STD 883	TEST FIG.	TEST CONDITIONS (PINS UNDER TEST D/F = DIP AND FP C = CCP)	LIMITS		UNIT
						MIN	MAX	
83	Threshold Voltage N-Channel	V_{THN}	-	4(k)	B Input at Ground All Other Inputs: $V_{IN} = 5V_{dc}$ $V_{DD} = 5V_{dc}$, $I_{SS} = -10\mu A$ (Pin D/F 7) (Pin C 10)	-0.7	-3.0	V
84	Threshold Voltage P-Channel	V_{THP}	-	4(l)	B Input at Ground A Input connected to V_{DD} All Other Inputs: $V_{IN} = -5V_{dc}$ $V_{SS} = -5V_{dc}$, $I_{DD} = 10\mu A$ (Pin D/F 14) (Pin C 20)	0.7	3.0	V
85 to 92	Input Clamp Voltage (to V_{SS})	V_{IC1}	-	4(m)	I_{IN} (Under Test) = $-100\mu A$ $V_{DD} = \text{Open}$, $V_{SS} = 0V_{dc}$ All Other Pins Open (Pins D/F 1-2-5-6-8-9-12-13) (Pins C 2-4-7-9-12-14-17-19)	-	-2.0	V
93 to 100	Input Clamp Voltage (to V_{DD})	V_{IC2}	-	4(n)	V_{IN} (Under Test) = $6V_{dc}$ $V_{SS} = \text{Open}$, $R = 30k\Omega$; (Pins D/F 1-2-5-6-8-9-12-13) (Pins C 2-4-7-9-12-14-17-19)	3.0	-	V

NOTES

- GO-NO-GO Test, each pattern of Test Table 4(a).
 $V_{OH} \geq V_{DD} - 0.5V_{dc}$ $V_{OL} \leq 0.5V_{dc}$
- Maximum time to output comparator strobe 300 μ sec.
- Test each pattern of Test Table 4(b).
- Interchange of forcing and measuring function is permitted.
- Measurement performed on a sample basis, LTPD 7 or less, with a Capacitance Bridge connected between each input under test and V_{SS} , only for Lots where LAT Level 2 is to be performed. (For LTPD sampling plan, see Annexe I of ESA/SCC 9000).
- Measurement performed on a sample basis, LTPD 7 or less, (see Annexe I of ESA/SCC 9000).

**TABLE 2 - ELECTRICAL MEASUREMENTS AT ROOM TEMPERATURE - a.c. PARAMETERS**

NO.	CHARACTERISTICS	SYMBOL	TEST METHOD MIL-STD 883	TEST FIG.	TEST CONDITIONS (PINS UNDER TEST D/F = DIP AND FP C = CCP)	LIMITS		UNIT
						MIN	MAX	
101 to 108	Input to Capacitance	C_{IN}	3012	4(o)	V_{IN} (Not Under Test) = 0Vdc $V_{DD} = V_{SS} = 0Vdc$ Note 5 (Pins D/F 1-2-5-6-8-9-12-13) (Pins C 2-4-7-9-12-14-17-19)	-	7.5	pF
109	Propagation Delay Low to High	t_{PLH}	3003	4(p)	V_{IN} (Under Test) = Pulse Generator V_{IN} (All Other Inputs) = 5Vdc $V_{DD} = 5Vdc, V_{SS} = 0Vdc$ Note 6 <u>Pins D/F</u> <u>Pins C</u> 2 to 3 4 to 5	-	200	ns
110	Propagation Delay High to Low	t_{PHL}	3003	4(p)	V_{IN} (Under Test) = Pulse Generator V_{IN} (All Other Inputs) = 5Vdc $V_{DD} = 5Vdc, V_{SS} = 0Vdc$ Note 6 <u>Pins D/F</u> <u>Pins C</u> 2 to 3 4 to 5	-	200	ns
111	Transition Time Low to High	t_{TLH}	3004	4(p)	V_{IN} (Under Test) = Pulse Generator V_{IN} (All Other Inputs) = 5Vdc $V_{DD} = 5Vdc, V_{SS} = 0Vdc$ Note 6 (Pin D/F 3) (Pin C 5)	-	150	ns
112	Transition Time High to Low	t_{THL}	3004	4(p)	V_{IN} (Under Test) = Pulse Generator V_{IN} (All Other Inputs) = 5Vdc $V_{DD} = 5Vdc, V_{SS} = 0Vdc$ Note 6 (Pin D/F 3) (Pin C 5)	-	150	ns

NOTES: See Page 19.

**TABLE 3(a) - ELECTRICAL MEASUREMENTS AT HIGH TEMPERATURE, + 125(+ 0-5) °C**

NO.	CHARACTERISTICS	SYMBOL	TEST METHOD MIL-STD 883	TEST FIG.	TEST CONDITIONS (PINS UNDER TEST D/F = DIP AND FP C = CCP)	LIMITS		UNIT
						MIN	MAX	
1	Functional Test	-	-	4(a)	Verify Truth Table without Load. $V_{DD} = 3V_{dc}$, $V_{SS} = 0V_{dc}$ Notes 1 and 2	-	-	-
2	Functional Test	-	-	4(a)	Verify Truth Table without Load. $V_{DD} = 15V_{dc}$, $V_{SS} = 0V_{dc}$ Notes 1 and 2	-	-	-
3 to 6	Quiescent Current	I_{DD}	3005	4(b)	$V_{IL} = 0V_{dc}$, $V_{IH} = 15V_{dc}$ $V_{DD} = 15V_{dc}$, $V_{SS} = 0V_{dc}$ Note 3 (Pin D/F 14) (Pin C 20)	-	1.0	μA
7 to 14	Input Current Low Level	I_{IL}	3009	4(c)	V_{IN} (Under Test) = $0V_{dc}$ V_{IN} (Remaining Inputs) = $15V_{dc}$ $V_{DD} = 15V_{dc}$, $V_{SS} = 0V_{dc}$ (Pins D/F 1-2-5-6-8-9-12-13) (Pins C 2-4-7-9-12-14-17-19)	-	-100	nA
15 to 22	Input Current High Level	I_{IH}	3010	4(d)	V_{IN} (Under Test) = $15V_{dc}$ V_{IN} (Remaining Inputs) = $0V_{dc}$ $V_{DD} = 15V_{dc}$, $V_{SS} = 0V_{dc}$ (Pins D/F 1-2-5-6-8-9-12-13) (Pins C 2-4-7-9-12-14-17-19)	-	100	nA
23 to 30	Output Voltage Low Level	V_{OL}	3007	4(e)	Gate Under Test: $V_{IN1} = 15V_{dc}$, $V_{IN2} = 0V_{dc}$ ($V_{IN1} = 0V_{dc}$, $V_{IN2} = 15V_{dc}$) All Other Gates: $V_{IN} = 0V_{dc}$ $V_{OUT} = \text{Open}$ $V_{DD} = 15V_{dc}$, $V_{SS} = 0V_{dc}$ (Pins D/F 3-4-10-11) (Pins C 5-6-15-16)	-	0.05	V

NOTES: See Page 19.

**TABLE 3(a) - ELECTRICAL MEASUREMENTS AT HIGH TEMPERATURE, + 125(+ 0-5) °C (CONT'D)**

NO.	CHARACTERISTICS	SYMBOL	TEST METHOD MIL-STD 883	TEST FIG.	TEST CONDITIONS (PINS UNDER TEST D/F = DIP AND FP C = CCP)	LIMITS		UNIT
						MIN	MAX	
31 to 34	Output Voltage High Level	V _{OH}	3006	4(f)	Gate Under Test: V _{IN} = 15Vdc All Other Gates: V _{IN} = 0Vdc V _{OUT} = Open V _{DD} = 15Vdc, V _{SS} = 0Vdc (Pins D/F 3-4-10-11) (Pins C 5-6-15-16)	14.95	-	V
35 to 42	Output Drive Current N-Channel	I _{OL1}	-	4(g)	Gate Under Test: V _{IN1} = 5Vdc, V _{IN2} = 0Vdc (V _{IN1} = 0Vdc, V _{IN2} = 5Vdc) V _{OUT} = 0.4Vdc All Other Gates: V _{IN} = 0Vdc V _{DD} = 5Vdc, V _{SS} = 0Vdc Note 4 (Pins D/F 3-4-10-11) (Pins C 5-6-15-16)	0.36	-	mA
43 to 50	Output Drive Current N-Channel	I _{OL2}	-	4(g)	Gate Under Test: V _{IN1} = 15Vdc, V _{IN2} = 0Vdc (V _{IN1} = 0Vdc, V _{IN2} = 15Vdc) V _{OUT} = 1.5Vdc All Other Gates: V _{IN} = 0Vdc V _{DD} = 15Vdc, V _{SS} = 0Vdc Note 4 (Pins D/F 3-4-10-11) (Pins C 5-6-15-16)	2.4	-	mA
51 to 54	Output Drive Current P-Channel	I _{OH1}	-	4(h)	Gate Under Test: All Inputs: V _{IL} = 5Vdc V _{OUT} = 4.6Vdc All Other Gates: V _{IN} = 0Vdc V _{DD} = 5Vdc, V _{SS} = 0Vdc Note 4 (Pins D/F 3-4-10-11) (Pins C 5-6-15-16)	-0.36	-	mA

NOTES: See Page 19.



TABLE 3(a) - ELECTRICAL MEASUREMENTS AT HIGH TEMPERATURE, + 125(+ 0-5) °C (CONT'D)

NO.	CHARACTERISTICS	SYMBOL	TEST METHOD MIL-STD 883	TEST FIG.	TEST CONDITIONS (PINS UNDER TEST D/F = DIP AND FP C = CCP)	LIMITS		UNIT
						MIN	MAX	
55 to 58	Output Drive Current P-Channel	I_{OH2}	-	4(h)	Gate Under Test: All Inputs: $V_{IN} = 15Vdc$ $V_{OUT} = 13.5Vdc$ All Other Gates: $V_{IN} = 0Vdc$ $V_{DD} = 15Vdc, V_{SS} = 0Vdc$ Note 4 (Pins D/F 3-4-10-11) (Pins C 5-6-15-16)	-2.4	-	mA
59 to 66	Input Voltage Low Level (Noise Immunity)	V_{IL1}	-	4(i)	Gate Under Test: $V_{IN1} = 1.5Vdc,$ $V_{IN2} = 3.5Vdc$ ($V_{IN1} = 3.5Vdc,$ $V_{IN2} = 1.5Vdc$) All Other Gates: $V_{IN} = 5Vdc$ $V_{DD} = 5Vdc, V_{SS} = 0Vdc$ (Pins D/F 3-4-10-11) (Pins C 5-6-15-16)	-	0.5	V
67 to 74	Input Voltage Low Level (Noise Immunity)	V_{IL2}	-	4(i)	Gate Under Test: $V_{IN1} = 11Vdc, V_{IN2} = 4Vdc$ ($V_{IN1} = 4Vdc, V_{IN2} = 11Vdc$) All Other Gates: $V_{IN} = 15Vdc$ $V_{DD} = 15Vdc, V_{SS} = 0Vdc$ (Pins D/F 3-4-10-11) (Pins C 5-6-15-16)	-	1.5	V
75 to 78	Input Voltage High Level (Noise Immunity)	V_{IH1}	-	4(j)	Gate Under Test: All Inputs: $V_{IN} = 3.5Vdc$ All Other Gates: $V_{IN} = 0Vdc$ $V_{DD} = 5Vdc, V_{SS} = 0Vdc$ (Pins D/F 3-4-10-11) (Pins C 5-6-15-16)	4.5	-	V
79 to 82	Input Voltage High Level (Noise Immunity)	V_{IH2}	-	4(j)	Gate Under Test: All Inputs: $V_{IN} = 11Vdc$ All Other Gates: $V_{IN} = 0Vdc$ $V_{DD} = 15Vdc, V_{SS} = 0Vdc$ (Pins D/F 3-4-10-11) (Pins C 5-6-15-16)	13.5	-	V

NOTES: See Page 19.

**TABLE 3(a) - ELECTRICAL MEASUREMENTS AT HIGH TEMPERATURE, +125(+0-5) °C (CONT'D)**

NO.	CHARACTERISTICS	SYMBOL	TEST METHOD MIL-STD 883	TEST FIG.	TEST CONDITIONS (PINS UNDER TEST D/F = DIP AND FP C = CCP)	LIMITS		UNIT
						MIN	MAX	
83	Threshold Voltage N-Channel	V_{THN}	-	4(k)	B Input at Ground All Other Inputs: $V_{IN} = 5V_{dc}$ $V_{DD} = 5V_{dc}$, $I_{SS} = -10\mu A$ (Pin D/F 7) (Pin C 10)	-0.3	-3.5	V
84	Threshold Voltage P-Channel	V_{THP}	-	4(l)	B Input at Ground A Input connected to V_{DD} All Other Inputs: $V_{IN} = -5V_{dc}$ $V_{SS} = -5V_{dc}$, $I_{DD} = 10\mu A$ (Pin D/F 14) (Pin C 20)	0.3	3.5	V

NOTES: See Page 19.



TABLE 3(b) - ELECTRICAL MEASUREMENTS AT LOW TEMPERATURE, -55(+5-0) °C

NO.	CHARACTERISTICS	SYMBOL	TEST METHOD MIL-STD 883	TEST FIG.	TEST CONDITIONS (PINS UNDER TEST D/F = DIP AND FP C = CCP)	LIMITS		UNIT
						MIN	MAX	
1	Functional Test	-	-	4(a)	Verify Truth Table without Load. $V_{DD} = 3V_{dc}$, $V_{SS} = 0V_{dc}$ Notes 1 and 2	-	-	-
2	Functional Test	-	-	4(a)	Verify Truth Table without Load. $V_{DD} = 15V_{dc}$, $V_{SS} = 0V_{dc}$ Notes 1 and 2	-	-	-
3 to 6	Quiescent Current	I_{DD}	3005	4(b)	$V_{IL} = 0V_{dc}$, $V_{IH} = 15V_{dc}$ $V_{DD} = 15V_{dc}$, $V_{SS} = 0V_{dc}$ Note 3 (Pin D/F 14) (Pin C 20)	-	100	nA
7 to 14	Input Current Low Level	I_{IL}	3009	4(c)	V_{IN} (Under Test) = $0V_{dc}$ V_{IN} (Remaining Inputs) = $15V_{dc}$ $V_{DD} = 15V_{dc}$, $V_{SS} = 0V_{dc}$ (Pins D/F 1-2-5-6-8-9-12-13) (Pins C 2-4-7-9-12-14-17-19)	-	-50	nA
15 to 22	Input Current High Level	I_{IH}	3010	4(d)	V_{IN} (Under Test) = $15V_{dc}$ V_{IN} (Remaining Inputs) = $0V_{dc}$ $V_{DD} = 15V_{dc}$, $V_{SS} = 0V_{dc}$ (Pins D/F 1-2-5-6-8-9-12-13) (Pins C 2-4-7-9-12-14-17-19)	-	50	nA
23 to 30	Output Voltage Low Level	V_{OL}	3007	4(e)	Gate Under Test: $V_{IN1} = 15V_{dc}$, $V_{IN2} = 0V_{dc}$ ($V_{IN1} = 0V_{dc}$, $V_{IN2} = 15V_{dc}$) All Other Gates: $V_{IN} = 0V_{dc}$ $V_{OUT} = \text{Open}$ $V_{DD} = 15V_{dc}$, $V_{SS} = 0V_{dc}$ (Pins D/F 3-4-10-11) (Pins C 5-6-15-16)	-	0.05	V

NOTES: See Page 19.



TABLE 3(b) - ELECTRICAL MEASUREMENTS AT LOW TEMPERATURE, -55(+5-0) °C (CONT'D)

NO.	CHARACTERISTICS	SYMBOL	TEST METHOD MIL-STD 883	TEST FIG.	TEST CONDITIONS (PINS UNDER TEST D/F = DIP AND FP C = CCP)	LIMITS		UNIT
						MIN	MAX	
31 to 34	Output Voltage High Level	V _{OH}	3006	4(f)	Gate Under Test: V _{IN} = 15Vdc All Other Gates: V _{IN} = 0Vdc V _{OUT} = Open V _{DD} = 15Vdc, V _{SS} = 0Vdc (Pins D/F 3-4-10-11) (Pins C 5-6-15-16)	14.95	-	V
35 to 42	Output Drive Current N-Channel	I _{OL1}	-	4(g)	Gate Under Test: V _{IN1} = 5Vdc, V _{IN2} = 0Vdc (V _{IN1} = 0Vdc, V _{IN2} = 5Vdc) V _{OUT} = 0.4Vdc All Other Gates: V _{IN} = 0Vdc V _{DD} = 5Vdc, V _{SS} = 0Vdc Note 4 (Pins D/F 3-4-10-11) (Pins C 5-6-15-16)	0.64	-	mA
43 to 50	Output Drive Current N-Channel	I _{OL2}	-	4(g)	Gate Under Test: V _{IN1} = 15Vdc, V _{IN2} = 0Vdc (V _{IN1} = 0Vdc, V _{IN2} = 15Vdc) V _{OUT} = 1.5Vdc All Other Gates: V _{IN} = 0Vdc V _{DD} = 15Vdc, V _{SS} = 0Vdc Note 4 (Pins D/F 3-4-10-11) (Pins C 5-6-15-16)	4.2	-	mA
51 to 54	Output Drive Current P-Channel	I _{OH1}	-	4(h)	Gate Under Test: All Inputs: V _{IL} = 5Vdc V _{OUT} = 4.6Vdc All Other Gates: V _{IN} = 0Vdc V _{DD} = 5Vdc, V _{SS} = 0Vdc Note 4 (Pins D/F 3-4-10-11) (Pins C 5-6-15-16)	-0.64	-	mA

NOTES: See Page 19.

**TABLE 3(b) - ELECTRICAL MEASUREMENTS AT LOW TEMPERATURE, -55(+5-0) °C (CONT'D)**

NO.	CHARACTERISTICS	SYMBOL	TEST METHOD MIL-STD 883	TEST FIG.	TEST CONDITIONS (PINS UNDER TEST D/F = DIP AND FP C = CCP)	LIMITS		UNIT
						MIN	MAX	
55 to 58	Output Drive Current P-Channel	I_{OH2}	-	4(h)	Gate Under Test: All Inputs: $V_{IN} = 15Vdc$ $V_{OUT} = 13.5Vdc$ All Other Gates: $V_{IN} = 0Vdc$ $V_{DD} = 15Vdc, V_{SS} = 0Vdc$ Note 4 (Pins D/F 3-4-10-11) (Pins C 5-6-15-16)	-4.2	-	mA
59 to 66	Input Voltage Low Level (Noise Immunity)	V_{IL1}	-	4(i)	Gate Under Test: $V_{IN1} = 1.5Vdc,$ $V_{IN2} = 3.5Vdc$ ($V_{IN1} = 3.5Vdc,$ $V_{IN2} = 1.5Vdc$) All Other Gates: $V_{IN} = 5Vdc$ $V_{DD} = 5Vdc, V_{SS} = 0Vdc$ (Pins D/F 3-4-10-11) (Pins C 5-6-15-16)	-	0.5	V
67 to 74	Input Voltage Low Level (Noise Immunity)	V_{IL2}	-	4(i)	Gate Under Test: $V_{IN1} = 11Vdc, V_{IN2} = 4Vdc$ ($V_{IN1} = 4Vdc, V_{IN2} = 11Vdc$) All Other Gates: $V_{IN} = 15Vdc$ $V_{DD} = 15Vdc, V_{SS} = 0Vdc$ (Pins D/F 3-4-10-11) (Pins C 5-6-15-16)	-	1.5	V
75 to 78	Input Voltage High Level (Noise Immunity)	V_{IH1}	-	4(j)	Gate Under Test: All Inputs: $V_{IN} = 3.5Vdc$ All Other Gates: $V_{IN} = 0Vdc$ $V_{DD} = 5Vdc, V_{SS} = 0Vdc$ (Pins D/F 3-4-10-11) (Pins C 5-6-15-16)	4.5	-	V
79 to 82	Input Voltage High Level (Noise Immunity)	V_{IH2}	-	4(j)	Gate Under Test: All Inputs: $V_{IN} = 11Vdc$ All Other Gates: $V_{IN} = 0Vdc$ $V_{DD} = 15Vdc, V_{SS} = 0Vdc$ (Pins D/F 3-4-10-11) (Pins C 5-6-15-16)	13.5	-	V

NOTES: See Page 19.

TABLE 3(b) - ELECTRICAL MEASUREMENTS AT LOW TEMPERATURE, -55(+ 5-0) °C (CONT'D)

NO.	CHARACTERISTICS	SYMBOL	TEST METHOD MIL-STD 883	TEST FIG.	TEST CONDITIONS (PINS UNDER TEST D/F = DIP AND FP C = CCP)	LIMITS		UNIT
						MIN	MAX	
83	Threshold Voltage N-Channel	V_{THN}	-	4(k)	B Input at Ground All Other Inputs: $V_{IN} = 5V_{dc}$ $V_{DD} = 5V_{dc}$, $I_{SS} = -10\mu A$ (Pin D/F 7) (Pin C 10)	-0.7	-3.5	V
84	Threshold Voltage P-Channel	V_{THP}	-	4(l)	B Input at Ground A Input connected to V_{DD} All Other Inputs: $V_{IN} = -5V_{dc}$ $V_{SS} = -5V_{dc}$, $I_{DD} = 10\mu A$ (Pin D/F 14) (Pin C 20)	0.7	3.5	V

NOTES: See Page 19.



FIGURE 4 - CIRCUITS FOR ELECTRICAL MEASUREMENTS

FIGURE 4(a) - FUNCTIONAL TEST TABLE

PATTERN NO.	PIN NUMBERS												D.C. SUPPLY	
	1	2	3	4	5	6	8	9	10	11	12	13	7	14
1	0	1	0	1	1	1	1	1	1	1	1	1	0	V _{DD}
2	1	1	1	0	0	1	1	1	1	1	1	1	↓	↓
3	1	1	1	1	1	1	0	1	0	1	1	1	↓	↓
4	1	1	1	1	1	1	1	1	1	0	0	1	↓	↓
5	1	0	0	1	1	1	1	1	1	1	1	1	↓	↓
6	1	1	1	0	1	0	1	1	1	1	1	1	↓	↓
7	1	1	1	1	1	1	1	0	0	1	1	1	↓	↓
8	1	1	1	1	1	1	1	1	1	0	1	0	↓	↓
9	0	0	0	0	0	0	0	0	0	0	0	0	↓	↓
10	1	1	1	1	1	1	1	1	1	1	1	1	↓	↓

NOTES

- Figure 4(a) illustrates one series of test patterns. Any other pattern series must be agreed with the Qualifying Space Agency and shall be included as an Appendix.
- Logic Level Definitions: 1 = V_{IH} = V_{DD}, 0 = V_{IL} = V_{SS}.

FIGURE 4(b) - QUIESCENT CURRENT TEST TABLE

PATTERN NO.	PIN NUMBERS											D.C. SUPPLY		
	INPUTS								OUTPUTS				7	14
	1	2	5	6	8	9	12	13	3	4	10	11		
1	1	0	1	0	1	0	1	0	X	X	X	X	V _{SS}	V _{DD}
2	0	1	0	1	0	1	0	1	X	X	X	X	↓	↓
3	1	1	1	1	1	1	1	1	X	X	X	X	↓	↓
4	0	0	0	0	0	0	0	0	X	X	X	X	↓	↓

NOTES

- Figure 4(b) illustrates one series of test patterns. Any other pattern series must be agreed with the Qualifying Space Agency and shall be included as an Appendix.
- Logic Level Definitions: 1 = V_{IH} = V_{DD}, 0 = V_{IL} = V_{SS}, X = Don't Care.



FIGURE 4 - CIRCUITS FOR ELECTRICAL MEASUREMENTS (CONTINUED)

FIGURE 4(c) - LOW LEVEL INPUT CURRENT

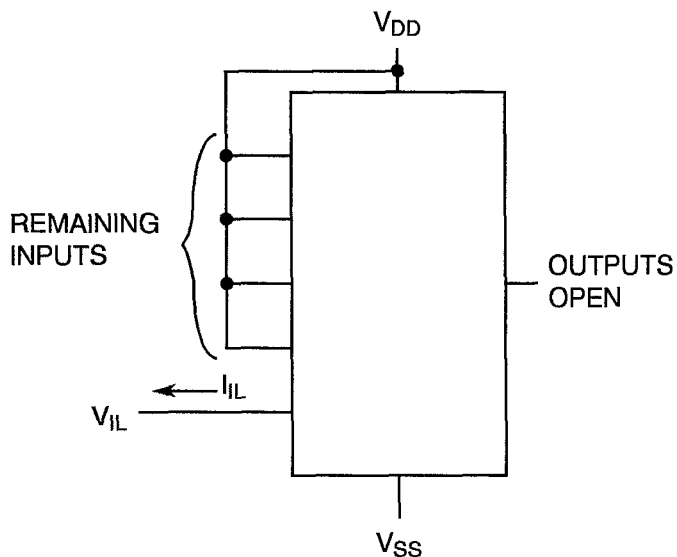

NOTES

1. Each input to be tested separately.

FIGURE 4(d) - HIGH LEVEL INPUT CURRENT

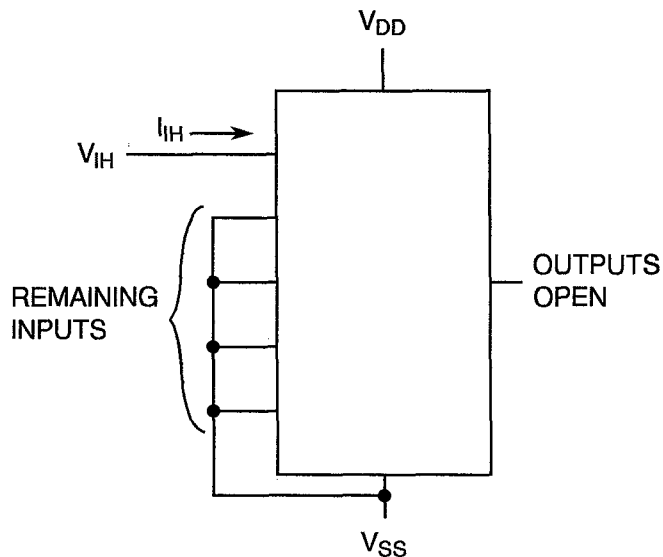

NOTES

1. Each input to be tested separately.

FIGURE 4(e) - LOW LEVEL OUTPUT VOLTAGE

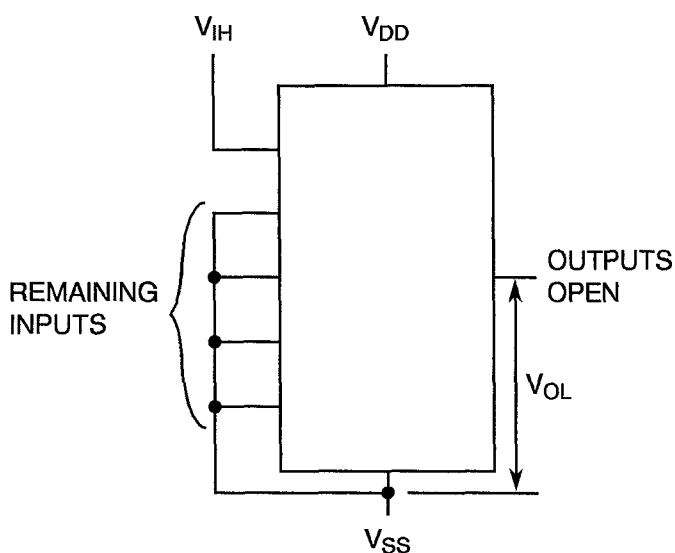

NOTES

1. Each output to be tested separately.

FIGURE 4(f) - HIGH LEVEL OUTPUT VOLTAGE

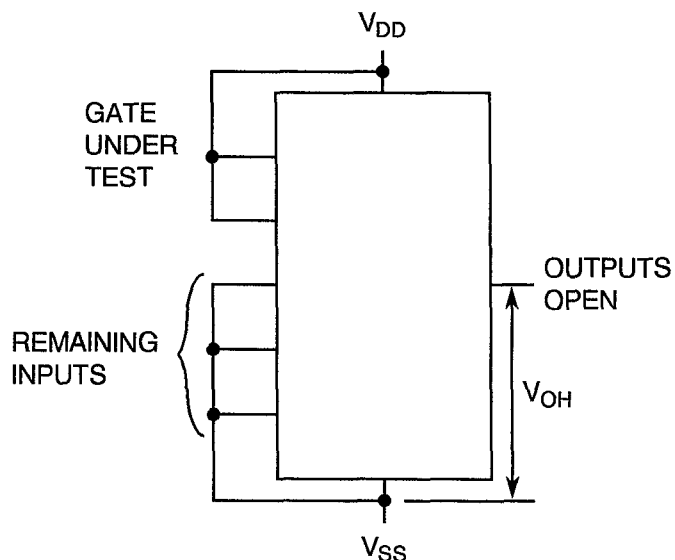

NOTES

1. Each output to be tested separately.



FIGURE 4 - CIRCUITS FOR ELECTRICAL MEASUREMENTS (CONTINUED)

FIGURE 4(g) - LOW LEVEL OUTPUT CURRENT

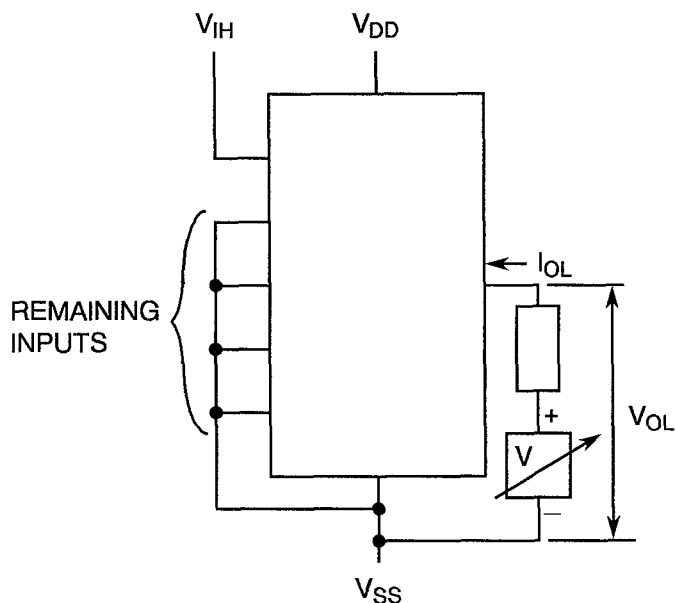

NOTES

- 1. Each output to be tested separately.

FIGURE 4(h) - HIGH LEVEL OUTPUT CURRENT

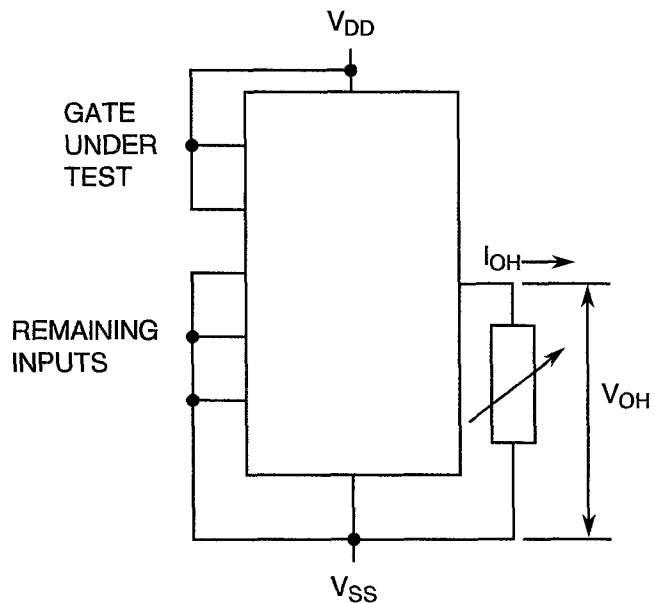

NOTES

- 1. Each output to be tested separately.

FIGURE 4(i) - LOW LEVEL INPUT VOLTAGE

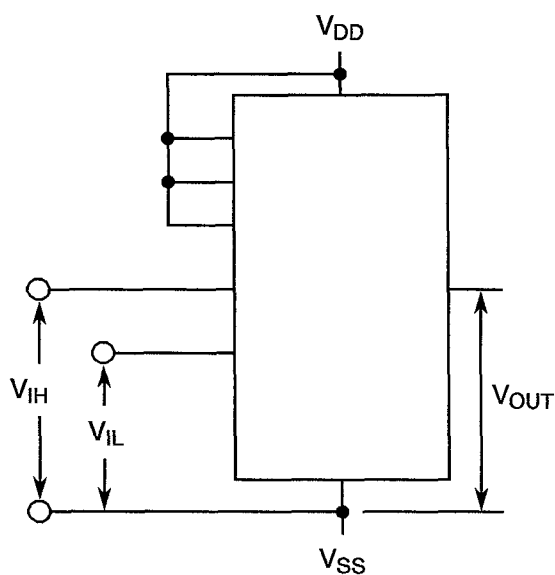

NOTES

- 1. Each output to be tested separately.

FIGURE 4(j) - HIGH LEVEL INPUT VOLTAGE

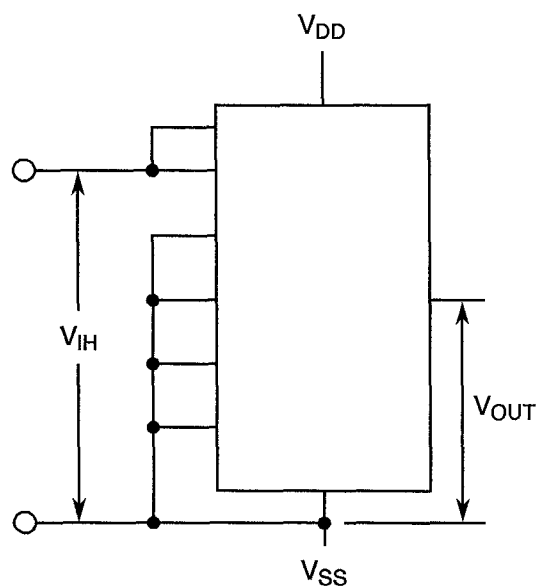

NOTES

- 1. Each output to be tested separately.



FIGURE 4 - CIRCUITS FOR ELECTRICAL MEASUREMENTS (CONTINUED)

FIGURE 4(k) - THRESHOLD VOLTAGE N-CHANNEL

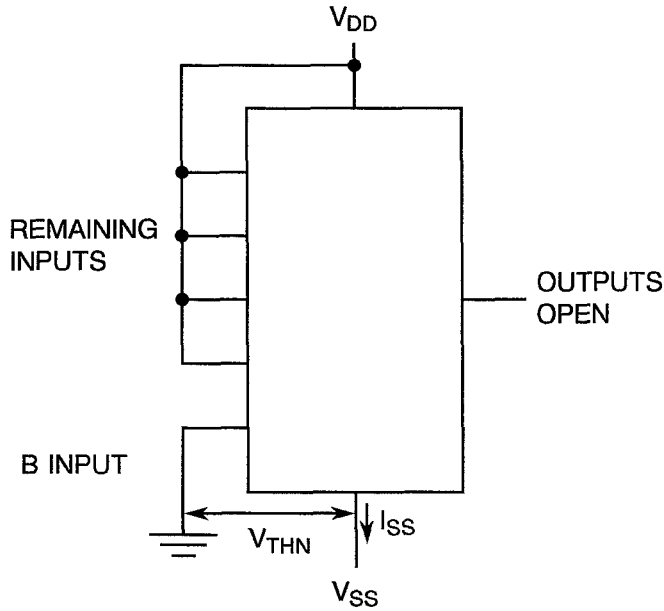

FIGURE 4(l) - THRESHOLD VOLTAGE P-CHANNEL

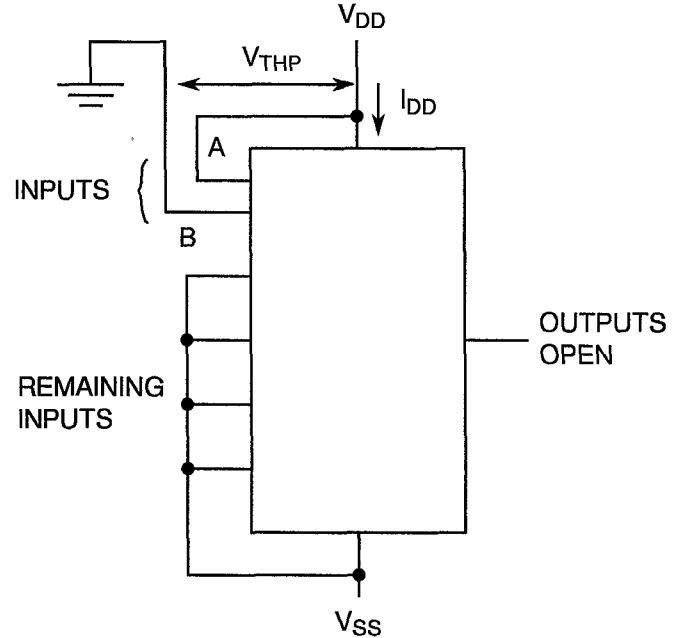
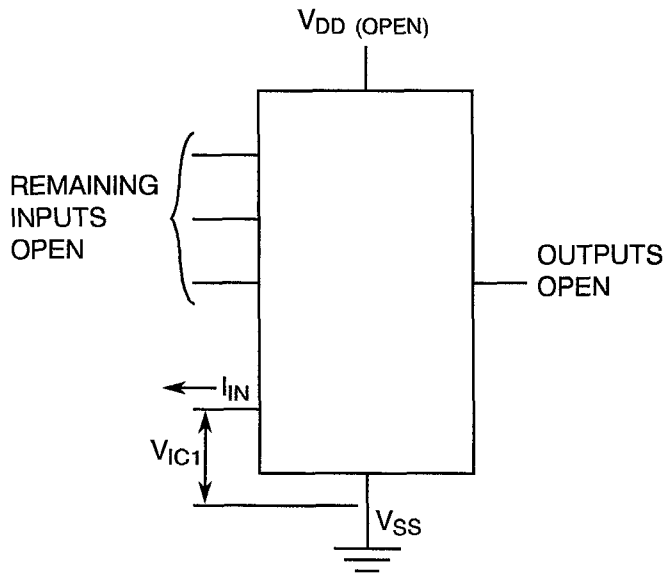

FIGURE 4(m) - INPUT CLAMP VOLTAGE (VSS)



NOTES

1. Each input to be tested separately.

FIGURE 4(n) - INPUT CLAMP VOLTAGE (VDD)

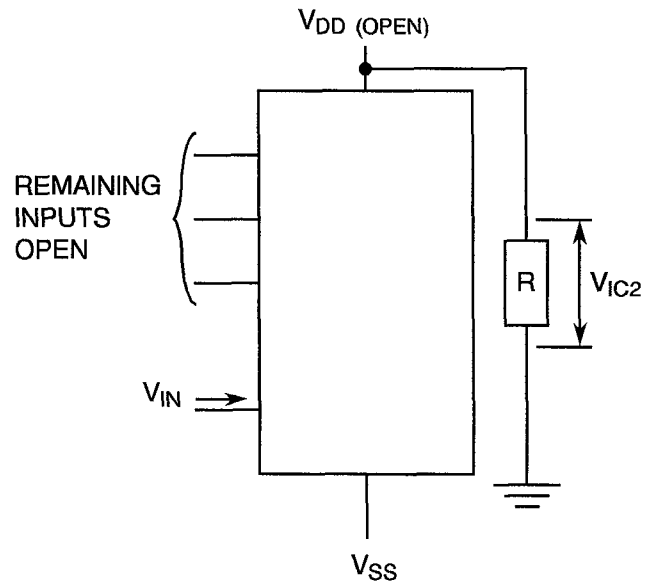

NOTES

1. Each input to be tested separately.



FIGURE 4 - CIRCUITS FOR ELECTRICAL MEASUREMENTS (CONTINUED)

FIGURE 4(o) - INPUT CAPACITANCE

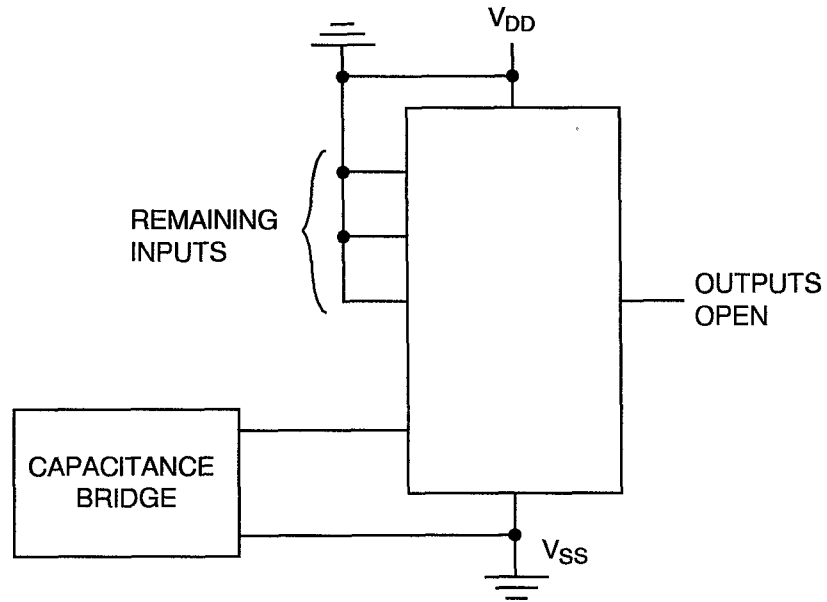

NOTES

1. Each input to be tested separately.
2. $f = 500\text{kHz}$ to 1MHz .



FIGURE 4 - CIRCUITS FOR ELECTRICAL MEASUREMENTS (CONTINUED)

FIGURE 4(p) - PROPAGATION DELAY AND TRANSITION TIME

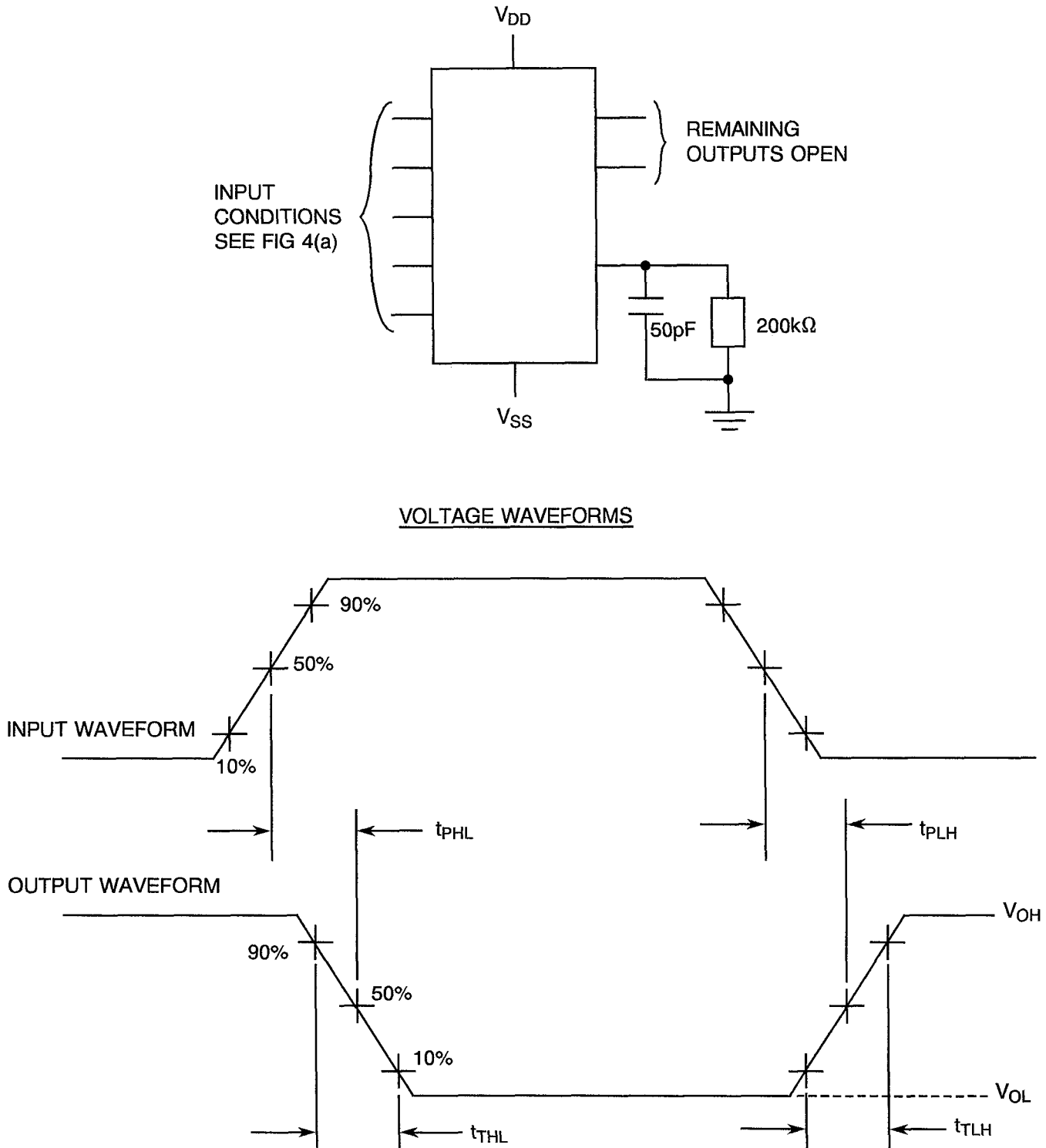

NOTES

1. Pulse Generator - $V_P = 0$ to V_{DD} , t_r and $t_f \leq 15$ ns, $f = 500$ kHz.

**TABLE 4 - PARAMETER DRIFT VALUES**

NO.	CHARACTERISTICS	SYMBOL	SPEC. AND/OR TEST METHOD	TEST CONDITIONS	CHANGE LIMITS (Δ)	UNIT
3 to 6	Quiescent Current	I_{DD}	As per Table 2	As per Table 2	± 50	nA
35 to 42	Output Drive Current N-Channel	I_{OL1}	As per Table 2	As per Table 2	± 15 (1)	%
51 to 54	Output Drive Current P-Channel	I_{OH1}	As per Table 2	As per Table 2	± 15 (1)	%
83	Threshold Voltage N-Channel	V_{THN}	As per Table 2	As per Table 2	± 0.3	V
84	Threshold Voltage P-Channel	V_{THP}	As per Table 2	As per Table 2	± 0.3	V

NOTES

1. Percentage of limit value if voltage is the measurement function.

**TABLE 5(a) - CONDITIONS FOR BURN-IN HIGH TEMPERATURE REVERSE BIAS, N-CHANNELS**

NO.	CHARACTERISTICS	SYMBOL	CONDITION	UNIT
1	Ambient Temperature	T_{amb}	+ 125(+ 0-5)	°C
2	Outputs - (Pins D/F 3-4-10-11) (Pins C 5-6-15-16)	V_{OUT}	Open	-
3	Inputs - (Pins D/F 2-6-8-12) (Pins C 4-9-12-17)	V_{IN}	V_{DD}	Vdc
4	Inputs - (Pins D/F 1-5-9-13) (Pins C 2-7-14-19)	V_{IN}	Ground	Vdc
5	Positive Supply Voltage (Pin D/F 14) (Pin C 20)	V_{DD}	15	Vdc
6	Negative Supply Voltage (Pin D/F 7) (Pin C 10)	V_{SS}	Ground	Vdc

NOTES

1. Input Load = Protection Resistor = 2k Ω minimum to 47k Ω maximum.

TABLE 5(b) - CONDITIONS FOR BURN-IN HIGH TEMPERATURE REVERSE BIAS, P-CHANNELS

NO.	CHARACTERISTICS	SYMBOL	CONDITION	UNIT
1	Ambient Temperature	T_{amb}	+ 125(+ 0-5)	°C
2	Outputs - (Pins D/F 3-4-10-11) (Pins C 5-6-15-16)	V_{OUT}	Open	-
3	Inputs - (Pins D/F 2-6-8-12) (Pins C 4-9-12-17)	V_{IN}	Ground	Vdc
4	Inputs - (Pins D/F 1-5-9-13) (Pins C 2-7-14-19)	V_{IN}	V_{DD}	Vdc
5	Positive Supply Voltage (Pin D/F 14) (Pin C 20)	V_{DD}	15	Vdc
6	Negative Supply Voltage (Pin D/F 7) (Pin C 10)	V_{SS}	Ground	Vdc

NOTES

1. Input Load = Protection Resistor = 2k Ω minimum to 47k Ω maximum.

**TABLE 5(c) - CONDITIONS FOR BURN-IN DYNAMIC**

NO.	CHARACTERISTICS	SYMBOL	CONDITIONS	UNIT
1	Ambient Temperature	T_{amb}	+ 125(+ 0-5)	°C
2	Outputs - (Pins D/F 3-4-10-11) (Pins C 5-6-15-16)	V_{OUT}	$V_{DD}/2$	Vdc
3	Inputs - (Pins D/F 1-5-8-12) (Pins C 2-7-12-17)	V_{IN}	V_{GEN}	Vac
4	Inputs - (Pins D/F 2-6-9-13) (Pins C 4-9-14-19)	V_{IN}	$V_{GEN}/2$	Vac
5	Pulse Voltage	V_{GEN}	0V to V_{DD}	Vac
6	Pulse Frequency Square Wave	f	$50k \leq f < 1M$ 50% Duty Cycle	Hz
7	Positive Supply Voltage (Pin D/F 14) (Pin C 20)	V_{DD}	15	Vdc
8	Negative Supply Voltage (Pin D/F 7) (Pin C 10)	V_{SS}	Ground	Vdc

NOTES

1. Input Load = Output Load = 2k Ω minimum to 47k Ω maximum.



FIGURE 5(a) - ELECTRICAL CIRCUIT FOR BURN-IN HIGH TEMPERATURE REVERSE BIAS, N-CHANNELS

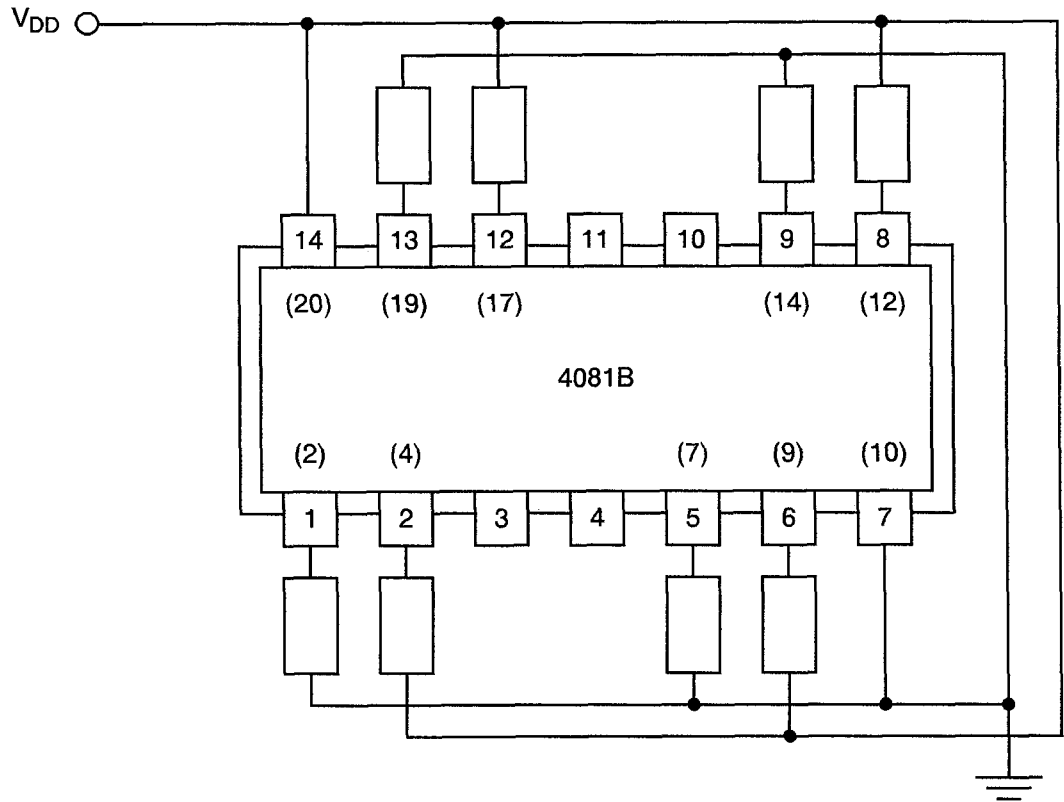

NOTES

- 1. Pin numbers in parenthesis are for the chip carrier package.

FIGURE 5(b) - ELECTRICAL CIRCUIT FOR BURN-IN HIGH TEMPERATURE REVERSE BIAS, P-CHANNELS

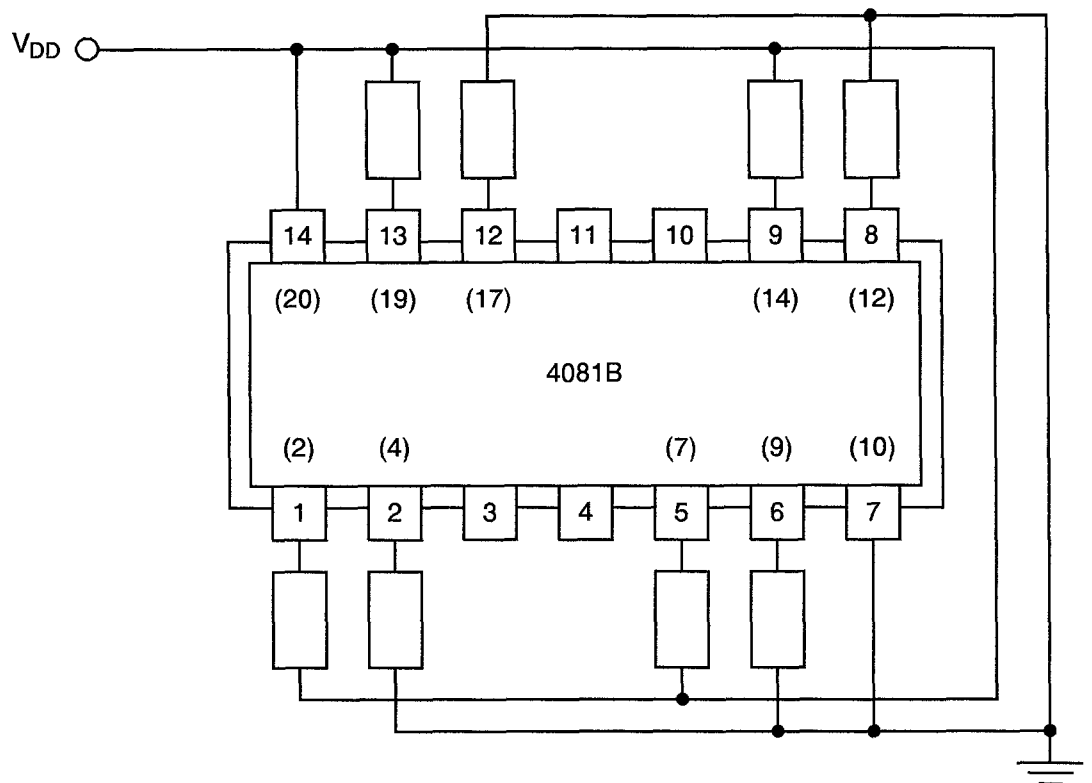

NOTES

- 1. Pin numbers in parenthesis are for the chip carrier package.



FIGURE 5(c) - ELECTRICAL CIRCUIT FOR BURN-IN DYNAMIC

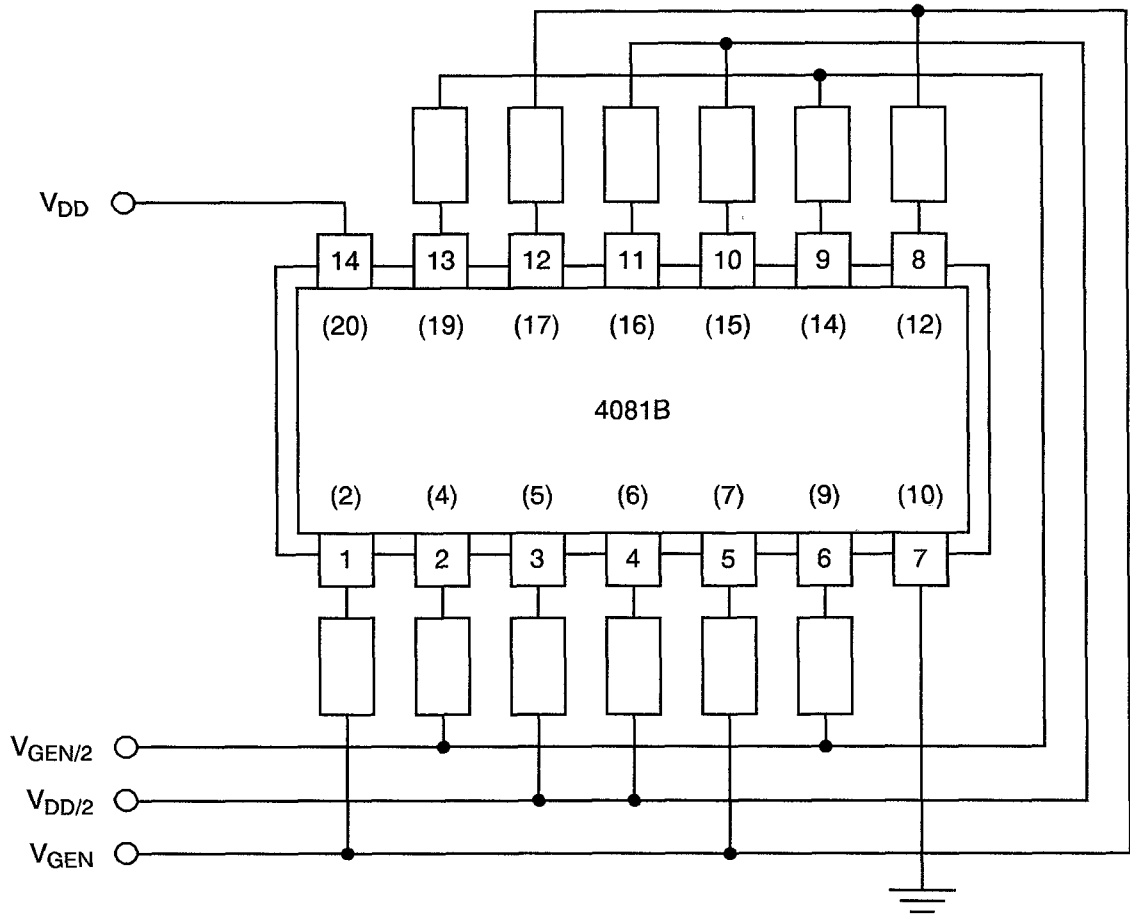

NOTES

1. Pin numbers in parenthesis are for the chip carrier package.



4.8 ENVIRONMENTAL AND ENDURANCE TESTS (CHARTS IV AND V OF ESA/SCC GENERIC SPECIFICATION NO. 9000)

4.8.1 Electrical Measurements on Completion of Environmental Tests

The parameters to be measured on completion of environmental tests are scheduled in Table 6. Unless otherwise stated, the measurements shall be performed at $T_{amb} = +22 \pm 3$ °C.

4.8.2 Electrical Measurements at Intermediate Points during Endurance Tests

The parameters to be measured at intermediate points during endurance tests are as scheduled in Table 6 of this specification.

4.8.3 Electrical Measurements on Completion of Endurance Tests

The parameters to be measured on completion of endurance testing are as scheduled in Table 6 of this specification. Unless otherwise stated, the measurements shall be performed at $T_{amb} = +22 \pm 3$ °C.

4.8.4 Conditions for Operating Life Test

The requirements for operating life testing are specified in Section 9 of ESA/SCC Generic Specification No. 9000. The conditions for operating life testing shall be as specified in Table 5(c) of this specification.

4.8.5 Electrical Circuits for Operating Life Tests

Circuits for use in performing the operating life tests are shown in Figure 5(c) of this specification.

4.8.6 Conditions for High Temperature Storage Test

The requirements for the high temperature storage test are specified in ESA/SCC Generic Specification No. 9000. The temperature to be applied shall be the maximum storage temperature specified in Table 1(b) of this specification.

**TABLE 6 - ELECTRICAL MEASUREMENTS ON COMPLETION OF ENVIRONMENTAL TESTS AND AT INTERMEDIATE POINTS AND ON COMPLETION OF ENDURANCE TESTING**

NO.	CHARACTERISTICS	SYMBOL	SPEC. AND/OR TEST METHOD	TEST CONDITIONS	CHANGE LIMITS (Δ)			UNIT
						MIN	MAX	
1	Functional Test	-	As per Table 2	As per Table 2	-	-	-	-
3 to 6	Quiescent Current	I_{DD}	As per Table 2	As per Table 2	± 50	-	-	nA
7 to 14	Input Current Low Level	I_{IL}	As per Table 2	As per Table 2	-	-	-50	nA
15 to 22	Input Current High Level	I_{IH}	As per Table 2	As per Table 2	-	-	50	nA
23 to 30	Output Voltage Low Level	V_{OL}	As per Table 2	As per Table 2	-	-	0.05	V
31 to 34	Output Voltage High Level	V_{OH}	As per Table 2	As per Table 2	-	14.95	-	V
35 to 42	Output Drive Current N-Channel	I_{OL1}	As per Table 2	As per Table 2	± 15 (1)	-	-	%
43 to 50	Output Drive Current N-Channel	I_{OL2}	As per Table 2	As per Table 2	± 15 (1)	-	-	%
51 to 54	Output Drive Current P-Channel	I_{OH1}	As per Table 2	As per Table 2	± 15 (1)	-	-	%
55 to 58	Output Drive Current P-Channel	I_{OH2}	As per Table 2	As per Table 2	± 15 (1)	-	-	%
59 to 66	Input Voltage Low Level (Noise Immunity)	V_{IL1}	As per Table 2	As per Table 2	-	-	0.5	V
75 to 78	Input Voltage High Level (Noise Immunity)	V_{IH1}	As per Table 2	As per Table 2	-	4.5	-	V
83	Threshold Voltage N-Channel	V_{THN}	As per Table 2	As per Table 2	± 0.3	-	-	V
84	Threshold Voltage P-Channel	V_{THP}	As per Table 2	As per Table 2	± 0.3	-	-	V

NOTES

1. Percentage of limit value if voltage is the measurement function.



SCC

ESA/SCC Detail Specification
No. 9201/052

Rev. 'C'

PAGE 42
ISSUE 4

APPENDIX 'A'

Page 1 of 1

AGREED DEVIATIONS FOR STMICROELECTRONICS (F)

ITEMS AFFECTED	DESCRIPTION OF DEVIATION
Para. 4.2.3	Para. 9.23, High Temperature Reverse Bias Burn-in: The temperature limits of MIL-STD-883, Para. 4.5.8(c) may be used. Para. 9.24, Power Burn-in: The temperature limits of MIL-STD-883, Para. 4.5.8(c) may be used.
Para. 4.2.4	Para. 9.21.1, Operating Life during Qualification Testing: The temperature limits of MIL-STD-883, Para. 4.5.8(c) may be used.
Para. 4.2.5	Para. 9.21.2, Operating Life during Lot Acceptance Testing: The temperature limits of MIL-STD-883, Para. 4.5.8(c) may be used.