



**TRANSISTORS, LOW POWER, NPN,
BASED ON TYPE 2N3700
ESCC Detail Specification No. 5201/004**

**ISSUE 1
October 2002**



	ESCC Detail Specification		PAGE ii ISSUE 1
---	---------------------------	--	--------------------

LEGAL DISCLAIMER AND COPYRIGHT

European Space Agency, Copyright © 2002. All rights reserved.

The European Space Agency disclaims any liability or responsibility, to any person or entity, with respect to any loss or damage caused, or alleged to be caused, directly or indirectly by the use and application of this ESCC publication.

This publication, without the prior permission of the European Space Agency and provided that it is not used for a commercial purpose, may be:

- copied in whole in any medium without alteration or modification.
- copied in part, in any medium, provided that the ESCC document identification, comprising the ESCC symbol, document number and document issue, is removed.



**europaean space agency
agence spatiale européenne**

Pages 1 to 19

TRANSISTORS, LOW POWER, NPN,

BASED ON TYPE 2N3700

ESA/SCC Detail Specification No. 5201/004

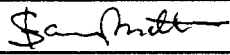
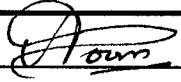

**space components
coordination group**

Issue/Rev.	Date	Approved by	
		SCCG Chairman	ESA Director General or his Deputy
Issue 5	October 1999		



DOCUMENTATION CHANGE NOTICE

Rev. Letter	Rev. Date	Reference	CHANGE Item	Approved DCR No.
		This issue supersedes Issue 4 and incorporates all modifications defined in Revisions 'A', 'B', 'C' and 'D' to Issue 4 and the changes agreed in the following DCRS:-		
		Cover page		None
		DCN		None
		Para. 1.2	: Text deleted and new text added	221529
		Para. 1.3	: In the text, "Table 1" changed to "Table 1(b)"	221529
		Para. 2	: Item (c) deleted.	221529
		Table 1(a)	: Lead Material column heading amended	221529
			: Variants 04 and 05 added	221529
		Table 1(b)	: Nos. 1 to 3, "Breakdown" deleted from Characteristics and "(BR)" from Symbol	221529
			: Nos. 5, 6 and 9, Variant references added to Characteristics	221529
			: Note references amended, Note 1 renumbered as 2 and new Notes 1, 3 and 4 added	221529
		Figure 2	: Existing drawing deleted, new one added and labelled as "Figure 2(a)"	221529
			: New Figure 2(b) added	221529
		Figure 3	: Note 1 amended	221529
		Para. 4.2.3	: Deviation (a) amended	221529
		Para. 4.3.2	: Text amended	221529
		Para. 4.3.3	: Second sentence modified	221529
		Para. 4.4.1	: Paragraph modified to include Variants 01 to 03 and Variants 04 to 05	221529
		Para. 4.4.2	: Existing text deleted and new text added	221529
		Para. 4.5.1	: Existing text deleted and new text added	221529
		Para. 4.5.5	: Paragraph deleted in toto	221529
		Para. 4.6.1	: "Unless otherwise specified .." added to the beginning of the second sentence	221529
		Para. 4.7.2	: Existing Para. 4.7.2 renumbered to Para. 4.7.3 and amended	221529
			: New Para. 4.7.2 entry added	221529
			: Existing Para. 4.7.3 deleted in toto	221529
		Para. 4.7.4	: New Para. 4.7.4 entry added	221529
		Para. 4.7.5	: New Para. 4.7.5 entry added	221529
		Table 2 a.c.	: Note reference added to Conditions column heading	221529
		Figure 4	: Entry added	221529
		Table 5	: Existing Table 5 renumbered as "5(b)" and Title amended	221529
			: No. 2, "(Note 1)" added to Conditions	221529
			: New Note 1 added	221529
			: New Table 5(a) added	221529
		Figure 5	: Existing Figure 5 renumbered as "5(b)" and Title amended	221529
			: New Figure 5(a) added	221529
		Para. 4.8.1	: "Unless otherwise stated," added to the beginning of the second sentence	221529
		Para. 4.8.2	: "of this specification" added to the end of the first sentence and second sentence added	221529
		Para. 4.8.3	: Second sentence amended to read " ... 5(b) for power burn-in"	221529
		Para. 4.8.4	: Sentence amended to read " ... 5(b) for power burn-in"	221529



TABLE OF CONTENTS

	<u>Page</u>
1. <u>GENERAL</u>	5
1.1 Scope	5
1.2 Component Type Variants	5
1.3 Maximum Ratings	5
1.4 Parameter Derating Information	5
1.5 Physical Dimensions	5
1.6 Functional Diagram	5
1.7 High Temperature Test Precautions	5
2. <u>APPLICABLE DOCUMENTS</u>	5
3. <u>TERMS, DEFINITIONS, ABBREVIATIONS, SYMBOLS AND UNITS</u>	5
4. <u>REQUIREMENTS</u>	10
4.1 General	10
4.2 Deviations from Generic Specification	10
4.2.1 Deviations from Special In-process Controls	10
4.2.2 Deviations from Final Production Tests	10
4.2.3 Deviations from Burn-in and Electrical Measurements	10
4.2.4 Deviations from Qualification Tests	10
4.2.5 Deviations from Lot Acceptance Tests	10
4.3 Mechanical Requirements	10
4.3.1 Dimension Check	10
4.3.2 Weight	10
4.3.3 Terminal Strength	10
4.4 Materials and Finishes	11
4.4.1 Case	11
4.4.2 Lead Material and Finish	11
4.5 Marking	11
4.5.1 General	11
4.5.2 Lead Identification	11
4.5.3 The SCC Component Number	11
4.5.4 Traceability Information	11
4.6 Electrical Measurements	12
4.6.1 Electrical Measurements at Room Temperature	12
4.6.2 Electrical Measurements at High and Low Temperatures	12
4.6.3 Circuits for Electrical Measurements	12
4.7 Burn-in Tests	12
4.7.1 Parameter Drift Values	12
4.7.2 Conditions for High Temperature Reverse Bias Burn-in	12
4.7.3 Conditions for Power Burn-in	12
4.7.4 Electrical Circuits for High Temperature Reverse Bias Burn-in	12
4.7.5 Electrical Circuits for Power Burn-in	12
4.8 Environmental and Endurance Tests	17
4.8.1 Electrical Measurements on Completion of Environmental Tests	17
4.8.2 Electrical Measurements at Intermediate Points and on Completion of Endurance Tests	17
4.8.3 Conditions for Operating Life Tests	17
4.8.4 Electrical Circuits for Operating Life Tests	17
4.8.5 Conditions for High Temperature Storage Test	17

**SCC**ESA/SCC Detail Specification
No. 5201/004

PAGE 4

ISSUE 5

Page**TABLES**

1(a)	Type Variants	6
1(b)	Maximum Ratings	6
2	Electrical Measurements at Room Temperature - d.c. Parameters	13
	Electrical Measurements at Room Temperature - a.c. Parameters	14
3	Electrical Measurements at High and Low Temperatures	14
4	Parameter Drift Values	15
5(a)	Conditions for High Temperature Reverse Bias Burn-in	15
5(b)	Conditions for Power Burn-in and Operating Life Tests	15
6	Electrical Measurements at Intermediate Points and on Completion of Endurance Testing	18

FIGURES

1	Parameter Derating Information	7
2	Physical Dimensions	8
3	Functional Diagram	9
4	Circuits for Electrical Measurements	14
5(a)	Electrical Circuit for High Temperature Reverse Bias Burn-in	16
5(b)	Electrical Circuit for Power Burn-in and Operating Life Tests	16

APPENDICES (Applicable to specific Manufacturers only)

'A'	Agreed Deviations for AEG - Telefunken (D)	19
-----	--	----

**1. GENERAL****1.1 SCOPE**

This specification details the ratings, physical and electrical characteristics, test and inspection data for Transistors, Low Power, NPN based on Type 2N3700. It shall be read in conjunction with ESA/SCC Generic Specification No. 5000, the requirements of which are supplemented herein.

1.2 COMPONENT TYPE VARIANTS

Variants of the basic transistors specified herein, which are also covered by this specification, are given in Table 1(a).

1.3 MAXIMUM RATINGS

The maximum ratings, which shall not be exceeded at any time during use or storage, applicable to the transistors specified herein, are scheduled in Table 1(b).

1.4 PARAMETER DERATING INFORMATION

The derating information applicable to the transistors specified herein is shown in Figure 1.

1.5 PHYSICAL DIMENSIONS

The physical dimensions of the transistors specified herein are shown in Figure 2.

1.6 FUNCTIONAL DIAGRAM

The functional diagram, showing lead identification, of the transistors specified herein, is shown in Figure 3.

1.7 HIGH TEMPERATURE TEST PRECAUTIONS

For tin-lead plated or solder-dipped lead finish, all tests to be performed at a temperature that exceeds +125°C shall be carried out in 100% inert atmosphere.

2. APPLICABLE DOCUMENTS

The following documents form part of this specification and shall be read in conjunction with it:-

- (a) ESA/SCC Generic Specification No. 5000 for Discrete Semiconductors.
- (b) MIL-STD-750, Test Methods and Procedures for Semiconductor Devices.

3. TERMS, DEFINITIONS, ABBREVIATIONS, SYMBOLS AND UNITS

For the purpose of this specification, the terms, definitions, abbreviations, symbols and units specified in ESA/SCC Basic Specification No. 21300 shall apply.

**TABLE 1(a) - TYPE VARIANTS**

VARIANT	BASED ON TYPE	CASE	FIGURE	LEAD MATERIAL AND/OR FINISH
01	2N3700	TO18	2(a)	D2
02	2N3700	TO18	2(a)	D3 or D4
03	2N3700	TO18	2(a)	D7
04	2N3700	CHIP CARRIER	2(b)	2
05	2N3700	CHIP CARRIER	2(b)	4

TABLE 1(b) - MAXIMUM RATINGS

No.	CHARACTERISTICS	SYMBOL	MAXIMUM RATING	UNIT	REMARKS
1	Collector Base Voltage	V_{CBO}	140	V	
2	Collector Emitter Voltage	V_{CEO}	80	V	
3	Emitter Base Voltage	V_{EBO}	7.0	V	
4	Collector Current	I_C	1.0	A	
5	Power Dissipation 1 All Variants Variants 04 and 05	P_{tot1}	0.5 0.76 (1)	W	$T_{amb} \leq +25^\circ\text{C}$ Note 2
6	Power Dissipation 2 Variants 01 to 03	P_{tot2}	1.8	W	$T_{case} \leq +25^\circ\text{C}$ Note 2
7	Operating Temperature Range	T_{op}	-65 to +200	$^\circ\text{C}$	T_{amb}
8	Storage Temperature Range	T_{stg}	-65 to +200	$^\circ\text{C}$	
9	Soldering Temperature Variants 01 to 03 Variants 04 to 05	T_{sol}	+260 +245	$^\circ\text{C}$	Note 3 Note 4

NOTES

- When mounted on a 15x15x0.6 mm ceramic substrate.
- For derating at T_{amb} or $T_{case} > +25^\circ\text{C}$, see Figure 1.
- Duration 10 seconds maximum at a distance of not less than 1.5mm from the device body and the same lead shall not be resoldered until 3 minutes have elapsed.
- Duration 5 seconds maximum and the same terminal shall not be resoldered until 3 minutes have elapsed.



FIGURE 1 - PARAMETER DERATING INFORMATION

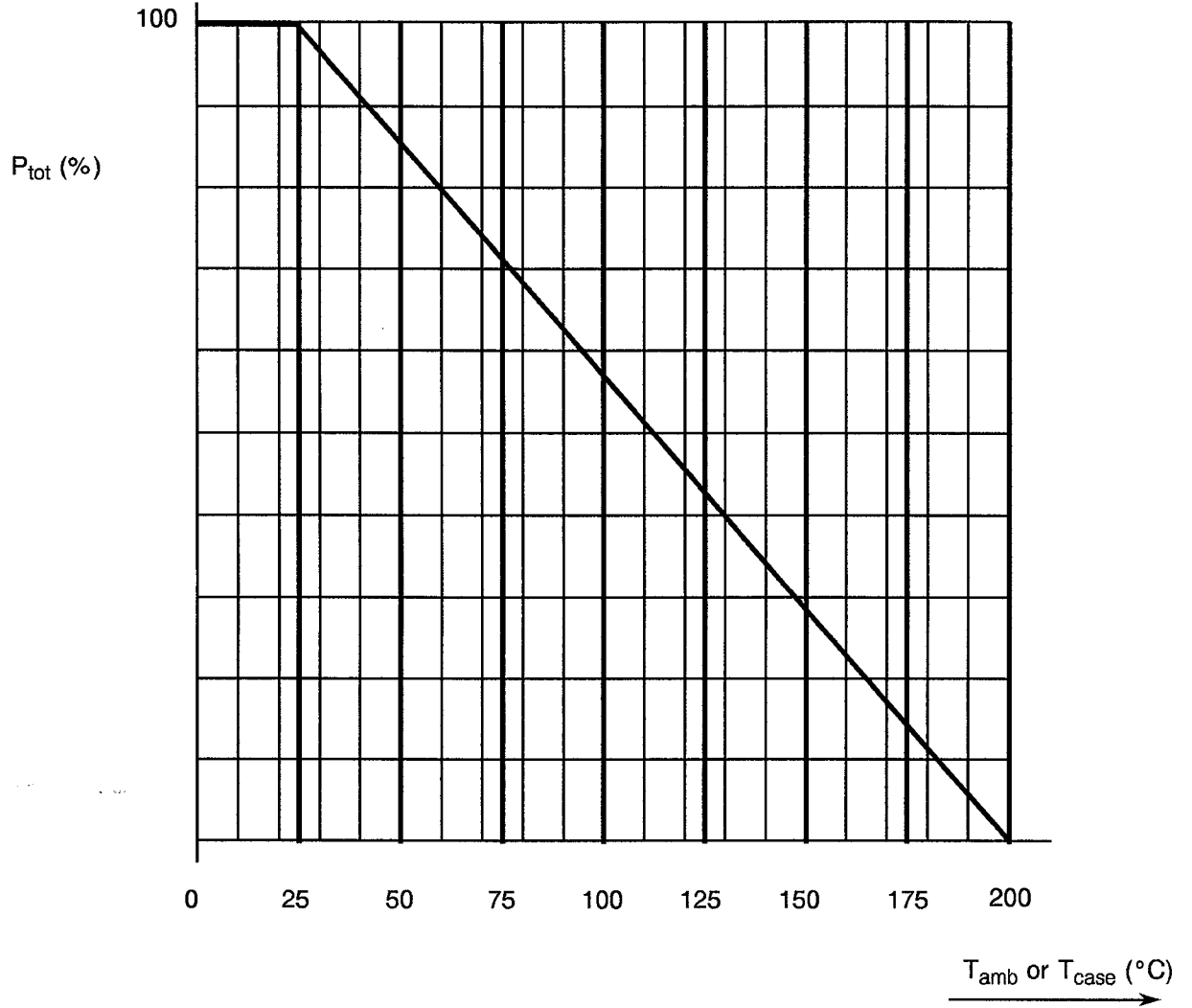

Power Dissipation versus Temperature



FIGURE 2 - PHYSICAL DIMENSIONS

FIGURE 2(a) - VARIANTS 01 TO 03

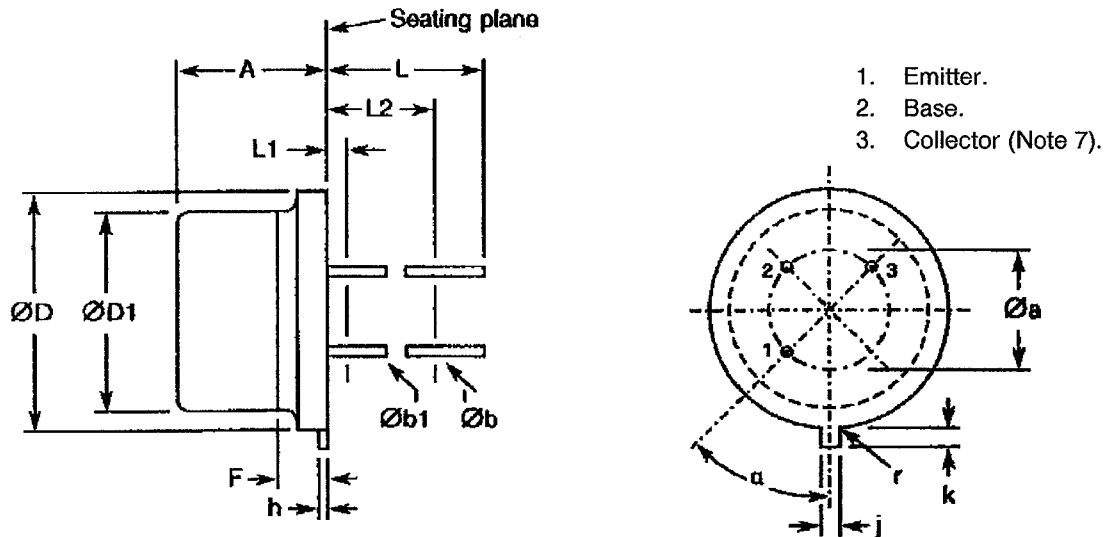

SYMBOL	MILLIMETRES		NOTES
	MIN.	MAX.	
A	4.32	5.33	
Øa	2.54 T.P.		4
Øb	0.41	0.53	5, 6
Øb1	0.41	0.48	5, 6
ØD	5.31	5.84	
ØD1	4.52	4.95	
F	-	0.76	3
h	0.23	1.04	
j	0.91	1.17	1
k	0.71	1.22	1, 2
L	12.70	19.05	5, 6
L1	-	1.27	5, 6
L2	6.35	-	5, 6
r	-	0.25	8
α	45° T.P.		4

NOTES

- Beyond r (radius) maximum, j shall be held for a minimum length of 0.28mm.
- k measured from maximum ØD.
- Body contour optional within zone defined by ØD, ØD1 and F.
- Leads at gauge plane 1.37 + 0.03 - 0.00 mm below seating plane shall be within 0.18mm radius of True Position (T.P.) at maximum material condition (MMC) relative to tab at MMC. The device may be measured by direct methods or by gauging procedure.
- Øb1 applies between L1 and L2. Øb applies between L2 and L minimum. Diameter is uncontrolled in L1 and beyond L minimum.
- All three leads.
- The collector shall be internally connected to the case.
- r (radius) applies to both inside corners of tab.



FIGURE 2 - PHYSICAL DIMENSIONS (CONTINUED)

FIGURE 2(b) - VARIANTS 04 TO 05

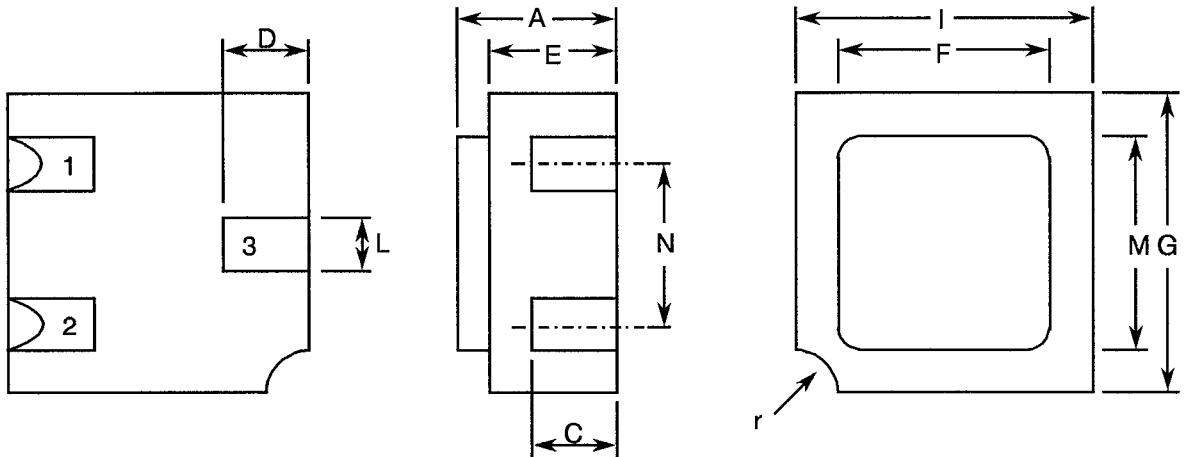

SYMBOL	MILLIMETRES		NOTES
	MIN	MAX	
A	1.15	1.50	
C	0.45	0.56	1
D	0.60	0.91	1
E	0.91	1.12	
F	1.90	2.15	
G	2.90	3.25	
I	2.40	2.85	
L	0.40	0.60	1
M	2.40	2.65	
N	1.80	2.00	
r	0.3 TYP.		

NOTES

1. The three pads have the same dimensions.

FIGURE 3 - FUNCTIONAL DIAGRAM

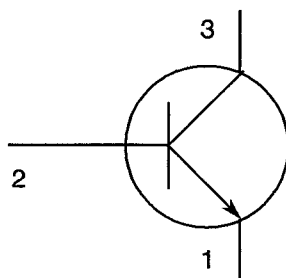

1. Emitter
2. Base
3. Collector

NOTES

1. For Variants 01 to 03, the collector is internally connected to the case.



4. REQUIREMENTS

4.1 GENERAL

The complete requirements for procurement of the transistors specified herein shall be as stated in this specification and ESA/SCC Generic Specification No. 5000 for Discrete Semiconductors. Deviations from the Generic Specification, applicable to this specification only, are listed in Para. 4.2.

Deviations from the applicable Generic Specification and this Detail Specification, formally agreed with specific Manufacturers on the basis that the alternative requirements are equivalent to the ESA/SCC requirements and do not affect the components' reliability, are listed in the appendices attached to this specification.

4.2 DEVIATIONS FROM GENERIC SPECIFICATION

4.2.1 Deviations from Special In-process Controls

None.

4.2.2 Deviations from Final Production Tests (Chart II)

None.

4.2.3 Deviations from Burn-in and Electrical Measurements (Chart III)

(a) Para. 7.1.1(a), High Temperature Reverse Bias Burn-in and subsequent electrical measurements related to this test shall be omitted.

4.2.4 Deviations from Qualification Tests (Chart IV)

None.

4.2.5 Deviations from Lot Acceptance Tests (Chart V)

None.

4.3 MECHANICAL REQUIREMENTS

4.3.1 Dimension Check

The dimensions of the transistors specified herein shall be checked. They shall conform to those shown in Figure 2.

4.3.2 Weight

The maximum weight of the transistors specified herein shall be 0.4 grammes for Variants 01 to 03 and 0.06 grammes for Variants 04 and 05.

4.3.3 Terminal Strength

The requirements for terminal strength testing are specified in Section 9 of ESA/SCC Generic Specification No. 5000. For Variants 01 to 03, the test conditions shall be as follows:-

Test Condition : 'E', Lead Fatigue.



4.4 MATERIALS AND FINISHES

The materials and finishes shall be as specified herein. Where a definite material is not specified, a material which will enable the transistors specified herein to meet the performance requirements of this specification shall be used. Acceptance or approval of any constituent material does not guarantee acceptance of the finished product.

4.4.1 Case

For Variants 01 to 03 the case shall be hermetically sealed and have a metal body with hard glass seals and the lid shall be welded, brazed, preform soldered or glass frit sealed.

For Variants 04 to 05 the case shall be hermetically sealed and have a ceramic body with a kovar lid.

4.4.2 Lead Material and Finish

For Variants 01 to 03, the lead material shall be Type 'D' with either Type '2', Type '3 or 4', or Type '7' finish in accordance with the requirements of ESA/SCC Basic Specification No. 23500. (See Table 1(a) for Type Variants).

For Variants 04 to 05, the terminal finish shall be Type '2' or Type '4' in accordance with the requirements of the ESA/SCC Basic Specification No. 23500. (See Table 1(a) for Type Variants).

4.5 MARKING

4.5.1 General

The marking of all components delivered to this specification shall be in accordance with with the requirements of ESA/SCC Basic Specification No. 21700 and the following paragraphs. When the component is too small to accommodate all of the marking specified, as much as space permits shall be marked and the marking information, in full, shall accompany the component in its primary package.

The information to be marked and the order of precedence, shall be as follows:-

- (a) Lead Identification.
- (b) The SCC Component Number.
- (c) Traceability Information.

4.5.2 Lead Identification

Lead identification shall be as shown in Figures 2 and 3.

4.5.3 The SCC Component Number

Each component shall bear the SCC Component Number which shall be constituted and marked as follows:

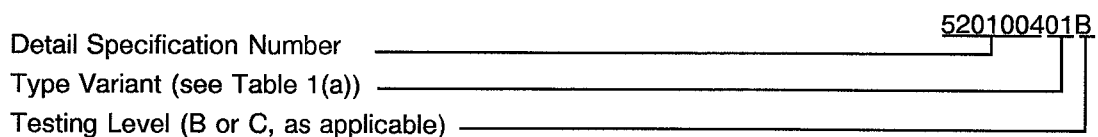

4.5.4 Traceability Information

Each component shall be marked in respect of traceability information in accordance with the requirements of ESA/SCC Basic Specification No. 21700.



4.6 ELECTRICAL MEASUREMENTS

4.6.1 Electrical Measurements at Room Temperature

The parameters to be measured at room temperature are scheduled in Table 2. Unless otherwise specified, the measurements shall be performed at $T_{amb} = +22 \pm 3$ °C.

4.6.2 Electrical Measurements at High and Low Temperatures

The parameters to be measured at high and low temperatures are scheduled in Table 3.

4.6.3 Circuits for Electrical Measurements

Circuits for use in performing the electrical measurements listed in Tables 2 and 3 of this specification are shown in Figure 4.

4.7 BURN-IN TESTS

4.7.1 Parameter Drift Values

The parameter drift values applicable to burn-in are specified in Table 4 of this specification. Unless otherwise stated, the measurements shall be performed at $T_{amb} = +22 \pm 3$ °C. The parameter drift values (Δ) applicable to the parameters scheduled, shall not be exceeded. In addition to these drift value requirements, the appropriate limit value specified for a given parameter in Table 2 shall not be exceeded.

4.7.2 Conditions for High Temperature Reverse Bias Burn-in (Table 5(a))

Not applicable.

4.7.3 Conditions for Power Burn-in

The requirements for power burn-in are specified in Section 7 of ESA/SCC Generic Specification No. 5000. The conditions for power burn-in shall be as specified in Table 5(b) of this specification.

4.7.4 Electrical Circuits for High Temperature Reverse Bias Burn-in (Figure 5(a))

Not applicable.

4.7.5 Electrical Circuits for Power Burn-in

Circuits for use in performing the power burn-in tests are shown in Figure 5(b) of this specification.

**TABLE 2 - ELECTRICAL MEASUREMENTS AT ROOM TEMPERATURE - d.c. PARAMETERS**

No.	CHARACTERISTICS	SYMBOL	MIL-STD-750 TEST METHOD	TEST CONDITION	LIMITS		UNIT
					MIN.	MAX.	
1	Collector-Emitter Breakdown Voltage	$V_{(BR)CEO}$	3011	$I_C = 30mA$ $I_B = 0$ Note 1	80	-	V
2	Collector-Base Breakdown Voltage	$V_{(BR)CBO}$	3001	$I_C = 100\mu A$ $I_E = 0$	140	-	V
3	Emitter-Base Breakdown Voltage	$V_{(BR)EBO}$	3026	$I_E = 100\mu A$ $I_C = 0$	7.0	-	V
4	Collector-Base Cut-off Current	I_{CBO}	3036	$V_{CE} = 90V$ $I_E = 0$	-	10	nA
5	Emitter-Base Cut-off Current	I_{EBO}	3061	$V_{EB} = 5.0V$ $I_C = 0$	-	10	nA
6	D.C. Forward Current Transfer Ratio 1	h_{FE1}	3076	$I_C = 10mA$ $V_{CE} = 10V$ Note 1	90	-	-
7	D.C. Forward Current Transfer Ratio 2	h_{FE2}	3076	$I_C = 150mA$ $V_{CE} = 10V$ Note 1	100	300	-
8	D.C. Forward Current Transfer Ratio 3	h_{FE3}	3076	$I_C = 500mA$ $V_{CE} = 10V$ Note 1	50	-	-
9	Collector-Emitter Saturation Voltage 1	$V_{CE(SAT1)}$	3071	$I_C = 150mA$ $I_B = 15mA$ Note 1	-	0.2	V
10	Collector-Emitter Saturation Voltage 2	$V_{CE(SAT2)}$	3071	$I_C = 500mA$ $I_B = 50mA$ Note 1	-	0.5	V
11	Base-Emitter Saturation Voltage	$V_{BE(SAT)}$	3066	$I_C = 150mA$ $I_B = 15mA$ Note 1	-	1.1	V

NOTES1. Pulsed measurement: Pulse length $\leq 300\mu s$; Duty Cycle $\leq 2.0\%$.

**TABLE 2 - ELECTRICAL MEASUREMENTS AT ROOM TEMPERATURE - a.c. PARAMETERS**

No.	CHARACTERISTICS	SYMBOL	MIL-STD-750 TEST METHOD	TEST CONDITION (NOTE 1)	LIMITS		UNIT
					MIN.	MAX.	
11	Input Capacitance	C_{ibo}	3240	$I_C = 0$ $V_{EB} = 0.5V$ $f = 1.0MHz$	-	60	pF
10	Output Capacitance	C_{obo}	3236	$V_{CB} = 10V$ $I_E = 0$ $f = 1.0MHz$	-	12	pF
12	A.C. Forward Current Transfer Ratio	h_{fe}	3206	$I_C = 50mA$ $V_{CE} = 10V$ $f = 20MHz$	5.0	-	-

NOTES

1. Tests performed on a sample basis, LTPD 7 or less.

TABLE 3 - ELECTRICAL MEASUREMENTS AT HIGH AND LOW TEMPERATURES

No.	CHARACTERISTICS	SYMBOL	MIL-STD-750 TEST METHOD	TEST CONDITION	LIMITS		UNIT
					MIN.	MAX.	
4	Collector-Base Cut-off Current	I_{CBO}	3036	$T_{amb} = +150^{\circ}C$ $V_{CB} = 90V$ $I_E = 0V$	-	10	μA
7	D.C. Forward Current Transfer Ratio 2	h_{FE2}	3076	$T_{amb} = -55^{\circ}C$ $I_C = 150mA$ $V_{CE} = 10V$ Note 1	40	-	-

NOTES

1. Pulsed measurement: Pulse length $\leq 300\mu s$; Duty Cycle $\leq 2.0\%$.

FIGURE 4 - CIRCUITS FOR ELECTRICAL MEASUREMENTS

Not applicable.

TABLE 4 - PARAMETER DRIFT VALUES

No.	CHARACTERISTICS	SYMBOL	SPEC. AND/OR TEST METHOD	TEST CONDITION	CHANGE LIMITS (Δ)	UNIT
4	Collector-Base Cut-off Current	I_{CBO}	As per Table 2	As per Table 2	± 1.0 or (1) ± 100	nA %
7	D.C. Forward Current Gain Ratio 2	h_{FE2}	As per Table 2	As per Table 2	± 15	%
9	Collector-Emitter Saturation Voltage 1	$V_{CE(SAT1)}$	As per Table 2	As per Table 2	± 20 or (1) ± 15	mV %

NOTES

1. Whichever is greater.

TABLE 5(a) - CONDITIONS FOR HIGH TEMPERATURE REVERSE BIAS BURN-IN

Not applicable.

TABLE 5(b) - CONDITIONS FOR POWER BURN-IN AND OPERATING LIFE TESTS

No.	CHARACTERISTIC	SYMBOL	CONDITION	UNIT
1	Ambient Temperature	T_{amb}	+ 20 to + 50	$^{\circ}C$
2	Power Dissipation	P_{tot}	Max. rating at T_{amb} according to derating curve (Note 1)	W
3	Collector-Base Voltage	V_{CB}	50	V

NOTES

1. See Item 5 of Table 1(b) and Figure 1.



FIGURE 5(a) - ELECTRICAL CIRCUIT FOR HIGH TEMPERATURE REVERSE BIAS BURN-IN

Not applicable.

FIGURE 5(b) - ELECTRICAL CIRCUIT FOR POWER BURN-IN AND OPERATING LIFE TESTS

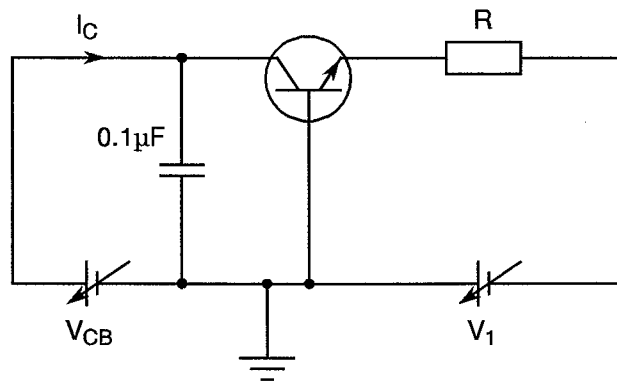

NOTES

1. V_{CB} set for 50V.
 V_1 adjusted so that I_C = current required to achieve $P_{tot} = \text{max.}$ at T_{amb} .
R chosen according to availability of V_1 , as long as: $V_1 + V_{CB} < V_{CEO}$.



4.8 ENVIRONMENTAL AND ENDURANCE TESTS (CHARTS IV AND V OF ESA/SCC GENERIC SPECIFICATION NO. 5000)

4.8.1 Electrical Measurements on Completion of Environmental Tests

The parameters to be measured on completion of environmental tests are scheduled in Table 2. Unless otherwise stated, the measurements shall be performed at $T_{amb} = +22 \pm 3$ °C.

4.8.2 Electrical Measurements at Intermediate Points and on Completion of Endurance Tests

The parameters to be measured at intermediate points and on completion of endurance testing are scheduled in Table 6 of this specification. Unless otherwise stated, the measurements shall be performed at $T_{amb} = +22 \pm 3$ °C.

4.8.3 Conditions for Operating Life Tests (Part of Endurance Testing)

The requirements for operating life testing are specified in Section 9 of ESA/SCC Generic Specification No. 5000. The conditions for operating life testing shall be the same as stated in Table 5(b) for power burn-in.

4.8.4 Electrical Circuits for Operating Life Tests

The circuit to be used for performance of the operating life test shall be the same as shown in Figure 5(b) for power burn-in.

4.8.5 Conditions for High Temperature Storage Test (Part of Endurance Testing)

The requirements for the high temperature storage test are specified in ESA/SCC Generic Specification No. 5000. The temperature to be applied shall be the maximum storage temperature specified in Table 1(b) of this specification.



TABLE 6 - ELECTRICAL MEASUREMENTS AT INTERMEDIATE POINTS AND ON COMPLETION OF ENDURANCE TESTING

No.	CHARACTERISTICS	SYMBOL	SPEC. AND/OR TEST METHOD	TEST CONDITION	LIMITS		UNIT
					MIN.	MAX.	
4	Collector-Base Cut-off Current	I_{CBO}	As per Table 2	As per Table 2	-	10	nA
7	D.C. Forward Current Transfer Ratio 2	h_{FE2}	As per Table 2	As per Table 2	100	300	-
9	Collector-Emitter Saturation Voltage 1	$V_{CE(SAT1)}$	As per Table 2	As per Table 2	-	0.2	V



APPENDIX 'A'

AGREED DEVIATIONS FOR AEG - TELEFUNKEN (D)

ITEMS AFFECTED	DESCRIPTION OF DEVIATIONS
Table 2 - a.c. Parameters	Test 3, a.c. Forward Current Transfer Ratio: In "Test Conditions" column, the frequency shall be $f = 30\text{MHz}$.