



Pages 1 to 16

ACCESSORIES FOR RECTANGULAR

CONNECTORS

3401/001, 3401/002 AND

CONNECTOR SAVERS 3401/020

ESCC Detail Specification No. 3401/022

ISSUE 2

May 2005



Document Custodian: European Space Agency - see <https://escies.org>

	ESCC Detail Specification No. 3401/022		PAGE i ISSUE 2
---	---	--	-------------------

LEGAL DISCLAIMER AND COPYRIGHT

European Space Agency, Copyright © 2005. All rights reserved.

The European Space Agency disclaims any liability or responsibility, to any person or entity, with respect to any loss or damage caused, or alleged to be caused, directly or indirectly by the use and application of this ESCC publication.

This publication, without the prior permission of the European Space Agency and provided that it is not used for a commercial purpose, may be:

- copied in whole in any medium without alteration or modification.
- copied in part, in any medium, provided that the ESCC document identification, comprising the ESCC symbol, document number and document issue, is removed.

DOCUMENTATION CHANGE NOTICE

(Refer to <https://escies.org> for ESCC DCR content)

DCR No.	CHANGE DESCRIPTION
174	Specification upissued to incorporate technical and editorial changes per DCR.



TABLE OF CONTENTS

	<u>Page</u>
1. <u>GENERAL</u>	4
1.1 Scope	4
1.2 Component Type Variants	4
1.3 Maximum Ratings	4
1.4 Parameter Derating Information	4
1.5 Physical Dimensions	4
2. <u>APPLICABLE DOCUMENTS</u>	4
3. <u>TERMS, DEFINITIONS, ABBREVIATIONS, SYMBOLS AND UNITS</u>	4
4. <u>REQUIREMENTS</u>	14
4.1 General	14
4.2 Deviations from Generic Specification	14
4.2.1 Deviations from Special In-process Controls	14
4.2.2 Deviations from Final Production Tests	14
4.2.3 Deviations from Burn-in and Electrical Measurements	14
4.2.4 Deviations from Qualification Tests	14
4.2.5 Deviations from Lot Acceptance Tests	14
4.3 Mechanical Requirements	14
4.3.1 Dimension Check	14
4.3.2 Weight	14
4.3.3 Torque Value	14
4.4 Materials and Finishes	15
4.4.1 Screw Lock Assemblies	15
4.4.2 Dust Caps	15
4.4.3 Magnetism Level	15
4.5 Marking	15
4.5.1 General	15
4.5.2 The ESCC Component Number	15
4.5.3 Characteristics	16
4.5.4 Traceability Information	16
4.6 Electrical Measurements	16
4.7 Burn-in and Electrical Measurements	16
4.8 Environmental and Endurance Tests	16

TABLES

1(a) Type Variants	5
1(b) Maximum Ratings	7

FIGURES

1 Paramter Derating Information	N/A
2 Physical Dimensions	8
2(a) Screw Lock Assemblies	8
2(b) Dust Caps	9
2(c) Potting Shells	10
2(d) Back-shells	10
2(e) Cable Clamps	11

APPENDICES (Applicable to specific Manufacturers only)

None.

1. GENERAL

1.1 SCOPE

This specification details the ratings, physical and electrical characteristics, test and inspection data for Accessories for Rectangular, Connectors and Connector Savers (D*M and D*MA). It shall be read in conjunction with ESCC Generic Specification No. 3401, the requirements of which are supplemented herein and ESCC Detail Specifications Nos. 3401/001, 3401/002 and 3401/020.

1.2 COMPONENT TYPE VARIANTS

The type variants of accessories covered by this specification are given in Table 1(a).

1.3 MAXIMUM RATINGS

The maximum ratings, which shall not be exceeded at any time during use or storage, applicable to the accessories specified herein, are given in Table 1(b).

1.4 PARAMETER DERATING INFORMATION

Not applicable.

1.5 PHYSICAL DIMENSIONS

The physical dimensions of the accessories specified herein are shown in Figure 2.

2. APPLICABLE DOCUMENTS

The following documents form part of this specification and shall be read in conjunction with it:-

- (a) ESCC Generic Specification No. 3401 for Connectors, Electrical, Circular and Rectangular.
- (b) ESCC Detail Specification No. 3401/001, Connectors, Electrical, Rectangular, Miniature, Non-removable Solder and Wire-Wrap-Type Contacts and, Removable Coaxial and Power, Crimp-Type and Solder-Type Contacts, based on Type D*M.
- (c) ESCC Detail Specification No. 3401/002, Connectors, Electrical, Rectangular, Miniature, Removable Crimp Type Contacts and, Removable Coaxial and Power Crimp-Type and Solder-Type Contacts, based on type D*MA.
- (d) ESCC Detail Specification 3401/020, Connector Savers, Electrical, Rectangular, Miniature, Removable Contacts, based on type D*BMA.
- (e) QQ-BB-613, Brass Material.
- (f) QQ-S-764/766 and QQ-P-35, Stainless steel material.
- (g) MIL-G-45204, Gold Plating, Electro-deposited.
- (h) MIL-C-14550, Copper Plating, Electro-deposited.

3. TERMS, DEFINITIONS, ABBREVIATIONS, SYMBOLS AND UNITS

For the purpose of this specification, the terms, definitions, abbreviations, symbols and units specified in ESCC Basic Specification No. 21300 shall apply.



TABLE 1(a) - TYPE VARIANTS

VARIANT	DESCRIPTION	WEIGHT (g)
01	Screw Lock Assembly Brass (Female)	1.9
02	Screw Lock Assembly Brass (Male/slotted head screw) Without Back Shell	0.85
03	Screw Lock Assembly Brass (Male/slotted head screw) Without Back Shell	0.85
04	Screw Lock Assembly Brass (Male/slotted head screw) Without Back Shell	1.0
05	Screw Lock Assembly Brass (Male/slotted head screw) Without Back Shell	1.0
06	Screw Lock Assembly Brass (Female) for Savers	2.0
07	Dust Cap (Female) Size E	N/A
08	Dust Cap (Male) Size E	N/A
09	Dust Cap (Female) Size A	N/A
10	Dust Cap (Male) Size A	N/A
11	Dust Cap (Female) Size B	N/A
12	Dust Cap (Male) Size B	N/A
13	Dust Cap (Female) Size C	N/A
14	Dust Cap (Male) Size C	N/A
15	Dust Cap (Female) Size D	N/A
16	Dust Cap (Male) Size D	N/A
17	Potting Shell Size A	N/A
18	Potting Shell Size B	N/A
19	Potting Shell Size C	N/A
20	Potting Shell Size D	N/A
21	Back-Shell for Strapped Connections Size A	5.0
22	Back-Shell for Strapped Connections Size B	6.0
23	Back-Shell for Strapped Connections Size C	8.0
24	Back-Shell for Strapped Connections Size D	8.0
25	Cable Clamp, Straight Size A	6.0
26	Cable Clamp, Straight Size B	7.0
27	Cable Clamp, Straight Size C	10
28	Cable Clamp, Straight Size D	10
29	Cable Clamp, Round Size E	9.0
30	Cable Clamp, Round Size A	11
31	Cable Clamp, Round Size B	12
32	Cable Clamp, Round Size C	15
33	Cable Clamp, Round Size D	16



TABLE 1(a) - TYPE VARIANTS (CONTINUED)

VARIANT	DESCRIPTION	WEIGHT (g)
34	Deep Straight Clamp	Size E 10
35	Deep Straight Clamp	Size A 12
36	Deep Straight Clamp	Size B 17
37	Deep Straight Clamp	Size C 24
38	Deep Straight Clamp	Size D 27
39	Right Angle Clamp	Size E 12
40	Right Angle Clamp	Size A 14
41	Right Angle Clamp	Size B 17.5
42	Right Angle Clamp	Size C 24
43	Right Angle Clamp	Size D 27
44	Screw Lock Assembly Brass (Male/slotted head screw)	With Back Shell 0.85
45	Screw Lock Assembly Brass (Male/slotted head screw)	With Back Shell 0.85
46	Screw Lock Assembly Brass (Male/slotted head screw)	With Back Shell 1.0
47	Screw Lock Assembly Brass (Male/slotted head screw)	With Back Shell 1.0
48	Screw Lock Assembly Stainless Steel (Female)	1.80
49	Screw Lock Assembly Stainless Steel (Male/slotted head screw)	Without Back Shell 0.8
50	Screw Lock Assembly Stainless Steel (Male/slotted head screw)	Without Back Shell 0.8
51	Screw Lock Assembly Stainless Steel (Male/slotted head screw)	Without Back Shell 1.0
52	Screw Lock Assembly Stainless Steel (Male/slotted head screw)	Without Back Shell 1.0
53	Screw Lock Assembly Stainless Steel (Female) for Savers	1.9
54	Screw Lock Assembly Stainless Steel (Male/slotted head screw)	With Back Shell 0.8
55	Screw Lock Assembly Stainless Steel (Male/slotted head screw)	With Back Shell 0.8
56	Screw Lock Assembly Stainless Steel (Male/slotted head screw)	With Back Shell 1.0
57	Screw Lock Assembly Stainless Steel (Male/slotted head screw)	With Back Shell 1.0
58	Screw Lock Assembly Brass (Female) for Feedthrough	2.0
59	Screw Lock Assembly Stainless Steel (Female) for Feedthrough	1.86
60	60° Angled Clamp	Size E 9.0
61	60° Angled Clamp	Size A 11
62	60° Angled Clamp	Size B 12
63	60° Angled Clamp	Size C 15
64	60° Angled Clamp	Size D 16

TABLE 1(a) - TYPE VARIANTS (CONTINUED)

VARIANT	DESCRIPTION	WEIGHT (g)
65	Screw Lock Assembly Brass (Male/hex. hole head screw) Without Back Shell	0.85
66	Screw Lock Assembly Brass (Male/hex. hole head screw) Without Back Shell	0.85
67	Screw Lock Assembly Brass (Male/hex. hole head screw) Without Back Shell	1.0
68	Screw Lock Assembly Brass (Male/hex. hole head screw) Without Back Shell	1.0
69	Screw Lock Assembly Brass (Male/hex. hole head screw) With Back Shell	0.85
70	Screw Lock Assembly Brass (Male/hex. hole head screw) With Back Shell	0.85
71	Screw Lock Assembly Brass (Male/hex. hole head screw) With Back Shell	1.0
72	Screw Lock Assembly Brass (Male/hex. hole head screw) With Back Shell	1.0
73	Screw Lock Assembly Stainless Steel (Male/hex. hole head screw) Without Back Shell	0.8
74	Screw Lock Assembly Stainless Steel (Male/hex. hole head screw) Without Back Shell	0.8
75	Screw Lock Assembly Stainless Steel (Male/hex. hole head screw) Without Back Shell	1.0
76	Screw Lock Assembly Stainless Steel (Male/hex. hole head screw) Without Back Shell	1.0
77	Screw Lock Assembly Stainless Steel (Male/hex. hole head screw) With Back Shell	0.8
78	Screw Lock Assembly Stainless Steel (Male/hex. hole head screw) With Back Shell	0.8
79	Screw Lock Assembly Stainless Steel (Male/hex. hole head screw) With Back Shell	1.0
80	Screw Lock Assembly Stainless Steel (Male/hex. hole head screw) With Back Shell	1.0

TABLE 1(b) - MAXIMUM RATINGS

No.	CHARACTERISTIC	SYMBOL	MAXIMUM RATING	UNIT	REMARKS
1	Operating Temperature Range	T_{op}	-55 to +125 (1)	°C	T_{amb}
2	Storage Temperature Range	T_{stg}	-55 to +125 (1)	°C	
3	Torque Value for Screws	T_{qe}	BRASS S.S. 5.5 6.6 3.3 4.4	cm.daN cm.daN	For Female (2) For Male

NOTES

1. Except for dust cap: +100°C.
2. Except for Variants 6, 53, 58 and 59 which shall be tightened to the torque specified for the Male.

FIGURE 1 - PARAMETER DERATING INFORMATION

Not applicable.

FIGURE 2 - PHYSICAL DIMENSIONS

FIGURE 2(a) - SCREW LOCK ASSEMBLIES

(All dimensions in millimetres)

MATED SPACING BETWEEN SHELL FRONT SURFACES

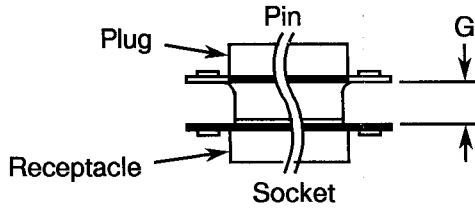

	MIN.	MAX.	NOTES
G	6.35	7.11	1
	6.12	6.88	2
H	4.37	5.13	-
	7.54	8.30	3
	14.35	14.65	4
J	15.49	16.25	5
	4.60	5.10	-
K	3.18	-	-
L	0.66	0.86	6

FEMALE

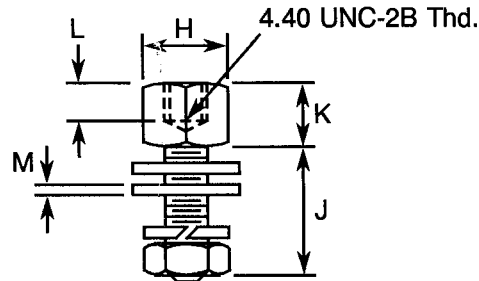

NOTES

1. For shell sizes E and A.
2. For shell sizes B, C and D.
3. Variants 01 and 48 (standard). To be used with all sizes of shells, P or S, with or without backshell.
4. Variants 06 and 53 (for savers). To be used with all sizes of shells.
5. Variants 58 and 59 (for feedthrough). To be used with all sizes of shells.
6. The spacing between the reference planes of 2 mated connectors shall be adjusted by the use of 0, 1 or 2 washers so that this spacing equals to dimension G.

MALE

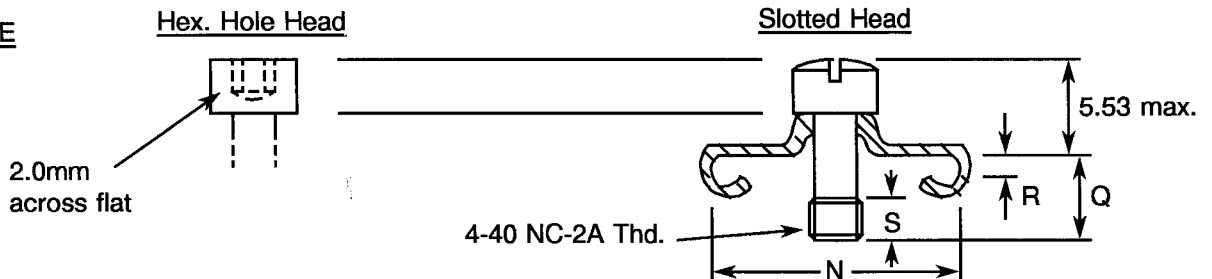

VARIANT		USE WITH SHELL SIZE	N		Q		R		S
BRASS	S.S.		MIN.	MAX.	MIN.	MAX.	MIN.	MAX.	MIN.
		<u>Without Back Shell</u>							
02-65	49-73	DA DE : (P or S) DB, DC : S	12.96	13.72	3.22	3.98	0.75	0.95	2.80
03-66	50-74	DB DC : P	12.96	13.72	3.22	3.98	0.95	1.15	2.80
04-67	51-75	DD : S	15.75	16.26	4.02	4.78	0.75	0.95	2.80
05-68	52-76	DD : P	15.75	16.26	4.02	4.78	0.95	1.15	2.80
		<u>With Back Shell</u>							
44-69	54-77	DA DE : (P or S) DB, DC : S	12.96	13.72	4.02	4.78	1.75	1.95	2.80
45-70	55-78	DB DC : P	12.96	13.72	4.02	4.78	2.00	2.20	2.80
46-71	56-79	DD : S	15.75	16.26	4.02	4.78	1.75	1.95	2.80
47-72	57-80	DD : P	15.75	16.26	4.02	4.78	2.00	2.20	2.80

FIGURE 2 - PHYSICAL DIMENSIONS (CONTINUED)

FIGURE 2(b) - DUST CAPS

(All dimensions in millimetres)

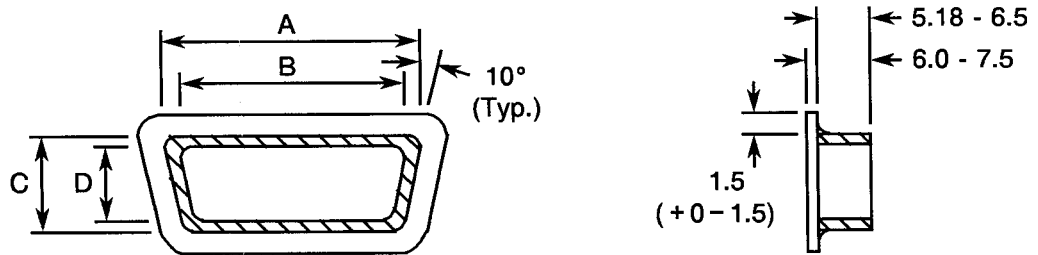

VARIANT	A		B		C		D	
	MIN.	MAX.	MIN.	MAX.	MIN.	MAX.	MIN.	MAX.
07	17.3	17.9	15.6	16.2	8.9	9.5	7.2	7.8
08	18.7	19.3	17.0	17.6	10.2	10.8	8.5	9.1
09	25.7	26.3	24.0	24.6	8.9	9.5	7.2	7.8
10	27.1	27.7	25.4	26.0	10.2	10.8	8.5	9.1
11	39.4	40.0	37.7	38.3	8.9	9.5	7.2	7.8
12	41.2	41.8	39.5	40.1	10.2	10.8	8.9	9.6
13	55.8	56.4	54.1	54.7	8.9	9.5	7.2	7.8
14	57.6	58.2	56.0	56.6	10.2	10.8	8.9	9.6
15	53.4	54.0	51.7	52.3	11.7	12.3	10.0	10.6
16	55.0	55.6	53.3	53.9	13.3	13.9	11.6	12.2

FIGURE 2 - PHYSICAL DIMENSIONS (CONTINUED)

FIGURE 2(c) - POTTING SHELLS

(All dimensions in millimetres)

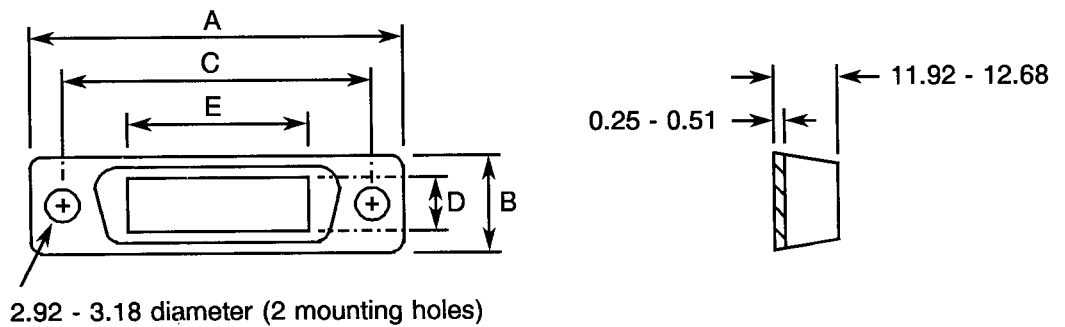

NOTES

1. Weight : Not applicable because not on board.

VARIANT	A		B		C		D		E	
	MIN.	MAX.	MIN.	MAX.	MIN.	MAX.	MIN.	MAX.	MIN.	MAX.
17	38.51	39.27	12.32	13.08	33.07	33.58	7.1	8.1	14.4	15.44
18	52.4	53.16	12.32	13.08	46.79	47.29	7.1	8.1	28.0	29.08
19	68.66	69.42	12.32	13.08	63.25	63.75	7.1	8.1	43.94	45.0
20	66.29	67.05	15.09	15.85	60.86	61.37	9.4	10.4	43.94	45.0

FIGURE 2(d) - BACK-SHELLS (FOR STRAPPED CONNECTIONS)

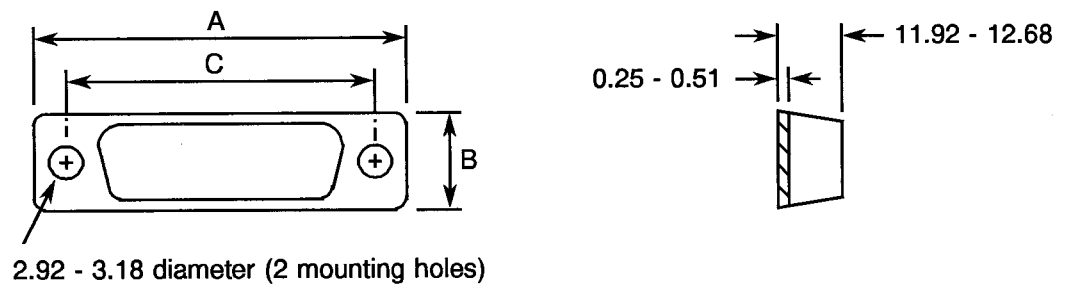

VARIANT	A		B		C	
	MIN.	MAX.	MIN.	MAX.	MIN.	MAX.
21	38.35	39.12	12.19	14.48	33.02	33.27
22	52.4	53.16	12.32	13.08	46.79	47.29
23	68.66	69.42	12.32	13.08	63.25	63.75
24	66.29	67.05	15.09	15.85	60.86	61.37

FIGURE 2 - PHYSICAL DIMENSIONS (CONTINUED)

FIGURE 2(e) - CABLE CLAMPS

(All dimensions in millimetres)

STRAIGHT CLAMP

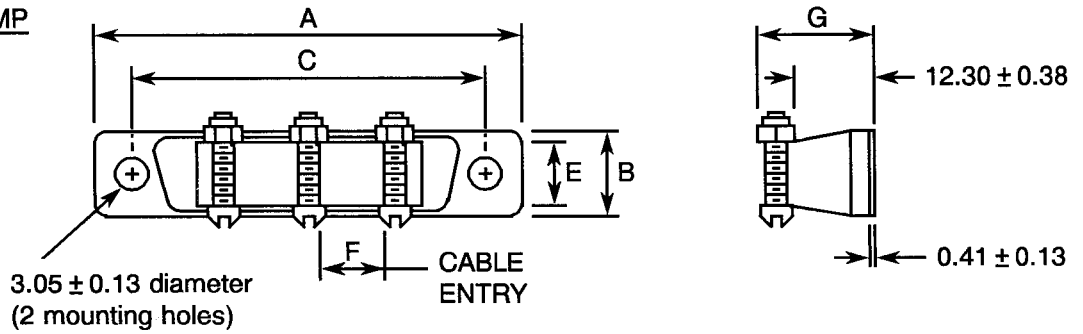

VARIANT	NO. OF CABLE-LOCKING SCREWS REQ'ED	A		B		C		E		F		G	
		MIN.	MAX.	MIN.	MAX.	MIN.	MAX.	MIN.	MAX.	MIN.	MAX.	MIN.	MAX.
25	2	38.51	39.27	12.32	13.08	33.17	33.45	7.12	7.88	7.52	8.28	15.7	16.7
26	2	52.4	53.16	12.32	13.08	46.87	47.17	7.12	7.88	19.82	20.58	15.7	16.7
27	3	68.66	69.42	12.32	13.08	63.37	63.63	7.12	7.88	17.07	17.83	15.7	16.7
28	3	66.29	67.05	15.09	15.85	60.97	61.23	9.52	10.28	17.07	17.83	17.3	18.3

ROUND CLAMP

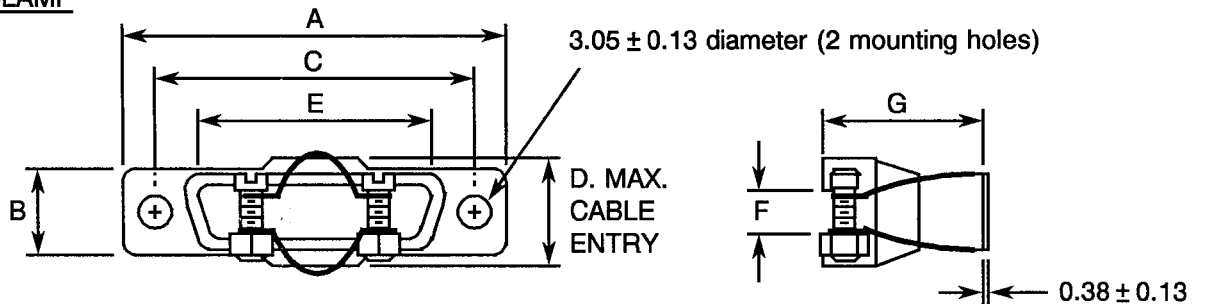

VARIANT	A		B		C		D		E		F		G	
	MIN.	MAX.	MIN.	MAX.	MIN.	MAX.	MIN.	MAX.	MIN.	MAX.	MIN.	MAX.	MIN.	MAX.
29	30.32	31.08	12.32	13.08	24.87	25.13	-	10.3	16.42	19.78	2.82	3.58	25.4	27.0
30	38.52	39.28	12.32	13.08	33.17	33.45	-	10.3	24.62	28.28	2.82	3.58	25.4	27.0
31	52.42	53.18	12.32	13.08	46.87	47.17	-	15.1	38.12	40.58	4.32	5.08	26.2	27.8
32	68.62	69.38	12.32	13.08	63.37	63.63	-	18.2	54.72	57.78	5.92	6.73	26.2	27.8
33	66.32	67.08	15.09	15.85	60.97	61.23	-	20.6	52.82	54.88	7.52	8.28	26.2	27.8

FIGURE 2 - PHYSICAL DIMENSIONS (CONTINUED)

FIGURE 2(e) - CABLE CLAMPS (CONTINUED)

(All dimensions in millimetres)

DEEP STRAIGHT CLAMP

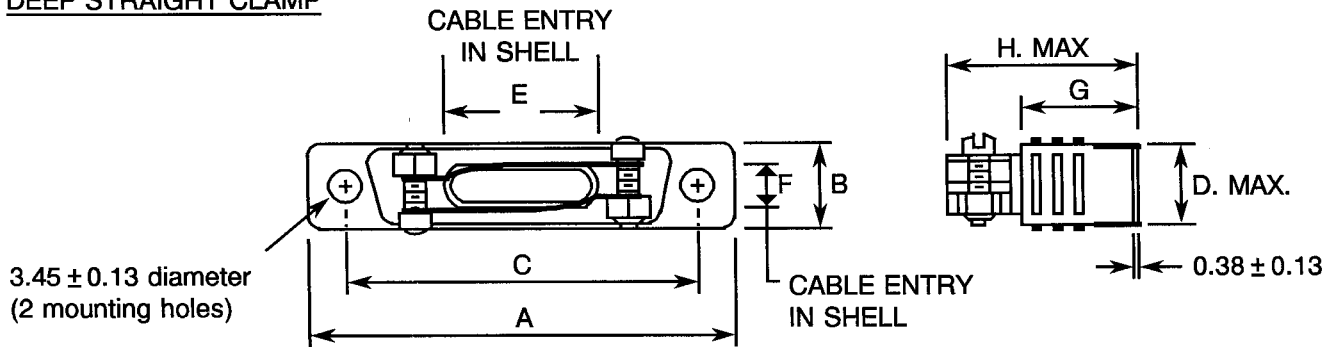

VARIANT	A		B		C		D	E		F		G		H
	MIN.	MAX.	MIN.	MAX.	MIN.	MAX.		MIN.	MAX.	MIN.	MAX.	MIN.	MAX.	
34	30.22	30.98	11.9	13.1	24.75	25.25	14.7	9.12	9.88	9.12	9.88	18.62	19.38	31.7
35	38.52	39.28	11.9	13.1	33.07	33.57	14.7	17.72	18.48	7.52	8.28	18.62	19.38	31.7
36	52.42	53.18	11.9	13.1	46.79	47.29	14.7	25.02	25.78	7.52	8.28	25.02	25.78	39.7
37	68.62	69.38	11.9	13.1	63.25	63.75	14.7	34.52	35.28	7.52	8.28	25.02	25.78	39.7
38	66.32	67.08	14.7	15.9	60.86	61.36	17.4	35.32	36.08	9.92	10.68	28.22	28.98	42.9

RIGHT ANGLE CLAMP

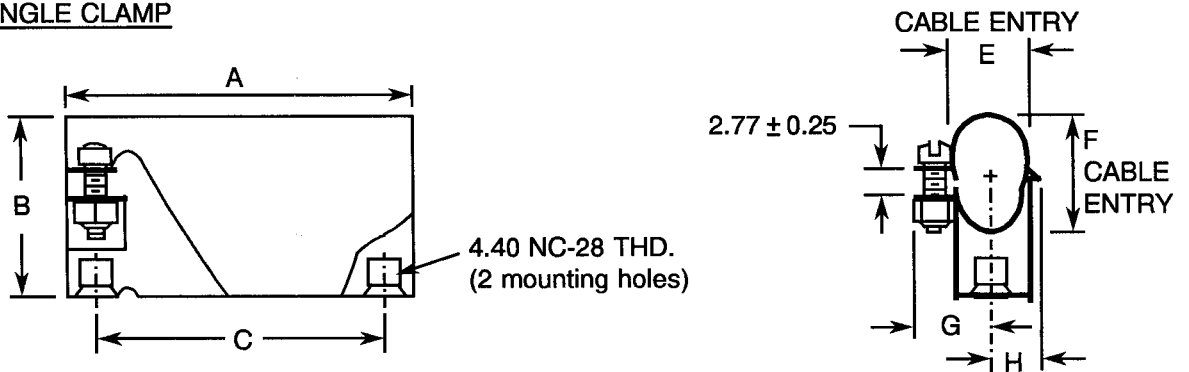

VARIANT	A		B		C		E		F		G		H	
	MIN.	MAX.	MIN.	MAX.	MIN.	MAX.	MIN.	MAX.	MIN.	MAX.	MIN.	MAX.	MIN.	MAX.
39	30.22	30.98	17.4	19.0	24.87	25.13	10.3	11.9	10.3	11.9	11.1	12.7	6.3	7.9
40	38.52	39.28	17.4	19.0	33.17	33.4	10.3	11.9	10.3	11.9	11.1	12.7	6.3	7.9
41	52.42	53.18	23.8	25.4	46.87	47.1	10.3	11.9	15.1	16.7	11.1	12.7	6.3	7.9
42	68.62	69.38	29.3	30.9	63.37	63.63	10.3	11.9	19.8	21.4	11.1	12.7	6.3	7.9
43	66.32	67.08	30.9	32.5	60.97	61.23	13.5	15.1	22.3	23.9	12.7	14.3	6.9	9.5

FIGURE 2 - PHYSICAL DIMENSIONS (CONTINUED)

FIGURE 2(e) - CABLE CLAMPS (CONTINUED)

(All dimensions in millimetres)

60° ANGLED CLAMP

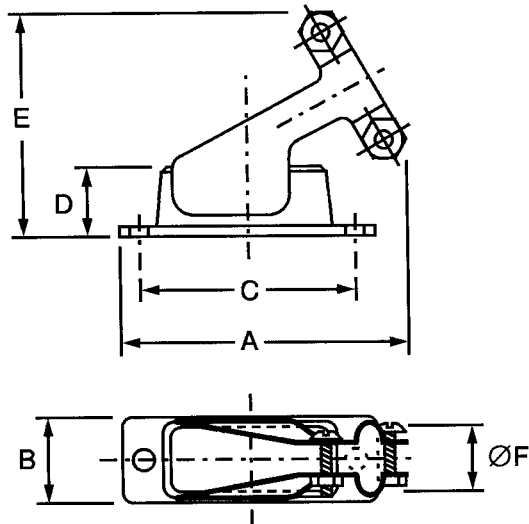

VARIANT	A	B	C	D	E	ØF
60	39.00	12.70	24.99	12.30	30.60	10.00
61	43.10	12.70	32.32	12.30	32.50	10.00
62	55.40	12.70	47.04	12.30	34.50	15.00
63	75.30	12.70	63.50	12.30	37.50	18.00
64	72.80	15.40	61.11	12.30	37.60	20.00

	<p style="text-align: center;">ESCC Detail Specification No. 3401/022</p>	<p>PAGE 14 ISSUE 2</p>
---	---	----------------------------

4. REQUIREMENTS

4.1 GENERAL

The complete requirements for procurement of the accessories specified herein are stated in this specification and ESCC Generic Specification No. 3401 for Connectors, Electrical, Circular and Rectangular. Deviations from the Generic Specification, applicable to this specification only, are listed in Para. 4.2

Deviations from the applicable Generic Specification and this Detail Specification, formally agreed with specific Manufacturers on the basis that the alternative requirements are equivalent to the ESCC requirements and do not affect the components' reliability, are listed in the appendices attached to this specification.

4.2 DEVIATIONS FROM GENERIC SPECIFICATION

4.2.1 Deviations from Special In-process Controls

- (a) Para. 5.2.2, Gold Plating Porosity: Not applicable.
- (b) Para. 5.2.3, Plating Thickness: Not applicable.

4.2.2 Deviations from Final Production Tests (Chart II)

Only the following tests shall be performed:-

- (a) Para. 4.4, Marking.
- (b) Para. 9.6, Dimension Check.
- (c) Para. 9.7, External Visual Inspection. The magnification shall be X3.

4.2.3 Deviations from Burn-in and Electrical Measurements (Chart III)

Not applicable.

4.2.4 Deviations from Qualification Tests (Chart IV)

Not applicable.

4.2.5 Deviations from Lot Acceptance Tests (Chart V)

Not applicable.

4.3 MECHANICAL REQUIREMENTS

4.3.1 Dimension Check

The dimensions of the accessories specified herein shall be verified in accordance with the requirements set out in Para. 9.6 of ESCC Generic Specification No. 3401 and shall conform to those shown in Figure 2 of this specification.

4.3.2 Weight

The maximum weight of the accessories specified herein shall be as shown in Table 1(a) of this specification.

4.3.3 Torque Value

The torque value to be used for tightening of the screws of the accessories specified herein shall be as mentioned in Table 1(b) of this specification.

	<p style="text-align: center;">ESCC Detail Specification No. 3401/022</p>		<p>PAGE 15 ISSUE 2</p>
---	---	--	----------------------------

4.4 MATERIALS AND FINISHES

The materials and finishes shall be as specified herein. Where a definite material is not specified, a material which will enable the accessories specified herein to meet the performance requirements of this specification shall be used. Acceptance or approval of any constituent material does not guarantee acceptance of the finished product.

4.4.1 Screw-Lock Assemblies (Male and Female)

Potting shells and back-shells:-

Material : Brass in accordance with QQ-B-613, Composition II.

Stainless steel in accordance with QQ-S-764/766 for screw Lock Variants 48 to 57.

Finish : Gold (0.7µm minimum) over copper (1µm minimum) in accordance with MIL-C-14450 and MIL-G-45204.

Passivated in accordance with QQ-P-35 for screw Lock Variants 48 to 57.

4.4.2 Dust Caps

Material : Red, black or white polyethelene.

4.4.3 Magnetism Level

The allowable value of magnetism shall not exceed that specified for the relevant level (see Para. 4.5.3.1).

4.5 MARKING

4.5.1 General

The marking of all components delivered to this specification shall be in accordance with the requirements of ESCC Basic Specification No. 21700 and the following paragraphs. When the component is too small to accomodate all of the marking as specified, as much as space permits shall be marked and the marking information, in full, shall accompany the component in its primary package.

The information to be marked and the order of precedence, shall be as follows:-

- (a) The ESCC Component Number.
- (b) Characteristics.
- (c) Traceability Information.

4.5.2 The ESCC Component Number

Each component shall bear the ESCC Component Number which shall be constituted and marked as follows:

	340102201B
Detail Specification Number _____	
Type Variant (see Table 1(a)) _____	
Testing Level _____	

4.5.3 Characteristics

The characteristics to be marked in the following order of precedence are:-

(a) Magnetism Level.

4.5.3.1 Magnetism Level (For Variants 01 to 06, 17 to 47, 58 and 60 to 72)

The following codes shall be used for magnetism level:-

CODE	DEFINITION
NMA	Magnetism Level: \leq 2000 gamma
NMB	Magnetism Level: \leq 200 gamma
NMC	Magnetism Level: \leq 20 gamma
NMD	Magnetism Level: \leq 2 gamma

4.5.4 Traceability Information

Traceability information shall be marked in accordance with the requirements of ESCC Basic Specification No. 21700.

4.6 ELECTRICAL MEASUREMENTS (TABLES 2 AND 3)

Not applicable.

4.7 BURN-IN AND ELECTRICAL MEASUREMENTS (TABLES 4 AND 5)

Not applicable.

4.8 ENVIRONMENTAL AND ENDURANCE TESTS (TABLE 6)

Not applicable.