



Page 1 of 20

**TRANSISTORS, MATCHED DUAL, PNP**

**BASED ON TYPE 2N3810**

**ESCC Detail Specification No. 5207/005**

Issue 8	October 2020
---------	--------------



Document Custodian: European Space Agency – see <https://escies.org>

**LEGAL DISCLAIMER AND COPYRIGHT**

European Space Agency, Copyright © 2020. All rights reserved.

The European Space Agency disclaims any liability or responsibility, to any person or entity, with respect to any loss or damage caused, or alleged to be caused, directly or indirectly by the use and application of this ESCC publication.

This publication, without the prior permission of the European Space Agency and provided that it is not used for a commercial purpose, may be:

- copied in whole, in any medium, without alteration or modification.
- copied in part, in any medium, provided that the ESCC document identification, comprising the ESCC symbol, document number and document issue, is removed.

**DOCUMENTATION CHANGE NOTICE**

(Refer to <https://escies.org> for ESCC DCR content)

DCR No.	CHANGE DESCRIPTION
1365, 1376	Specification updated to incorporate changes per DCR.

**TABLE OF CONTENTS**

1	GENERAL	5
1.1	SCOPE	5
1.2	APPLICABLE DOCUMENTS	5
1.3	TERMS, DEFINITIONS, ABBREVIATIONS, SYMBOLS AND UNITS	5
1.4	THE ESCC COMPONENT NUMBER AND COMPONENT TYPE VARIANTS	5
1.4.1	The ESCC Component Number	5
1.4.2	Component Type Variants	6
1.5	MAXIMUM RATINGS	7
1.6	PHYSICAL DIMENSIONS AND TERMINAL IDENTIFICATION	8
1.6.1	Metal Can Package (TO-78) - 6 lead	8
1.6.2	Chip Carrier Package (CCP) - 6 terminal	9
1.6.3	Flat package (FP) – 8 Pin	10
1.6.4	Die (Variant 12)	11
1.7	FUNCTIONAL DIAGRAM	12
1.8	MATERIALS AND FINISHES	12
1.8.1	Materials and Finishes of Packaged Components	12
1.8.2	Materials and Finishes of Die Components	12
2	REQUIREMENTS	12
2.1	GENERAL	12
2.1.1	Deviations from the Generic Specification	13
2.1.1.1	Deviation from Production Control – Chart F2	13
2.2	MARKING	13
2.3	TERMINAL STRENGTH	13
2.4	ELECTRICAL MEASUREMENTS AT ROOM, HIGH AND LOW TEMPERATURES	13
2.4.1	Room Temperature Electrical Measurements	13
2.4.2	High and Low Temperatures Electrical Measurements	16
2.5	PARAMETER DRIFT VALUES	16
2.6	INTERMEDIATE AND END-POINT ELECTRICAL MEASUREMENTS	17
2.7	HIGH TEMPERATURE REVERSE BIAS BURN-IN CONDITIONS	17
2.8	POWER BURN-IN CONDITIONS	17
2.9	OPERATING LIFE CONDITIONS	18
2.10	TOTAL DOSE RADIATION TESTING	18
2.10.1	Bias Conditions and Total Dose Level for Total dose Radiation Testing	18
2.10.2	Electrical Measurements for Radiation Testing	19
	APPENDIX 'A'	20

## 1 GENERAL

### 1.1 SCOPE

This specification details the ratings, physical and electrical characteristics and test and inspection data for the component type variants and/or the range of components specified below. It supplements the requirements of, and shall be read in conjunction with, the ESCC Generic Specification listed under Applicable Documents.

### 1.2 APPLICABLE DOCUMENTS

The following documents form part of this specification and shall be read in conjunction with it:

- (a) ESCC Generic Specification No. [5000](#)
- (b) [MIL-STD-750](#), Test Methods and Procedures for Semiconductor Devices

### 1.3 TERMS, DEFINITIONS, ABBREVIATIONS, SYMBOLS AND UNITS

For the purpose of this specification, the terms, definitions, abbreviations, symbols and units specified in ESCC Basic Specification No. [21300](#) shall apply.

### 1.4 THE ESCC COMPONENT NUMBER AND COMPONENT TYPE VARIANTS

#### 1.4.1 The ESCC Component Number

The ESCC Component Number shall be constituted as follows:

Example: 520700501R

- Detail Specification Reference: 5207005
- Component Type Variant Number: 01 (as required)
- Total Dose Radiation Level Letter: R (as required)

#### 1.4.2 Component Type Variants

The component type variants applicable to this specification are as follows:

Variant Number	Based on Type	Case	Lead/Terminal Material and/or Finish (Note 1)	Weight max g	Total Dose Radiation Level Letter (Note 2)
01	2N3810	TO-78	D2	0.95	R [100krad(Si)]
02	2N3810	TO-78	D3 or D4	0.95	R [100krad(Si)]
05	2N3810	TO-78	D7	0.95	R [100krad(Si)]
07	2N3810	CCP	2	0.2	R [100krad(Si)]
09	2N3810	CCP	4	0.2	R [100krad(Si)]
10	2N3810	FP	G2	0.7	R [100krad(Si)]
11	2N3810	FP	G4	0.7	R [100krad(Si)]
12	2N3810	Die (Note 3)	N/A	N/A	R [100krad(Si)]

**NOTES:**

1. The lead/terminal material and/or finish shall be in accordance with the requirements of ESCC Basic Specification No. [23500](#).
2. Total dose radiation level letters are defined in ESCC Basic Specification No. [22900](#). If an alternative radiation test level is specified in the Purchase Order, the letter shall be changed accordingly.
3. Variant 12 is a single transistor die; this Variant shall be ordered, tested and delivered in matched pairs. See Para. 1.6.4.

1.5 MAXIMUM RATINGS

The maximum ratings shall not be exceeded at any time during use or storage.

Maximum ratings shall only be exceeded during testing to the extent specified in this specification and when stipulated in Test Methods and Procedures of the ESCC Generic Specification.

Characteristics	Symbols	Maximum Ratings	Unit	Remarks
Collector-Base Voltage	$V_{CBO}$	-60	V	Over entire operating temperature range
Collector-Emitter Voltage	$V_{CEO}$	-60	V	
Emitter-Base Voltage	$V_{EBO}$	-5	V	
Collector Current	$I_C$	50	mA	Continuous
Power Dissipation (One Section) For TO-78, CCP and FP For TO-78	$P_{totO1}$ $P_{totO2}$	0.5 0.5	W W	At $T_{amb} \leq +25^\circ\text{C}$ At $T_{case} \leq +25^\circ\text{C}$
Power Dissipation (Both Sections) For TO-78, CCP and FP For TO-78	$P_{totB1}$ $P_{totB2}$	0.6 0.6	W W	At $T_{amb} \leq +25^\circ\text{C}$ At $T_{case} \leq +25^\circ\text{C}$
Thermal Resistance, Junction-to-Ambient	$R_{th(j-a)}$	350 291.7	$^\circ\text{C/W}$	For one section For both sections
Thermal Resistance, Junction-to-Case	$R_{th(j-c)}$	350 291.7	$^\circ\text{C/W}$	For one section For both sections Note 1
Operating Temperature Range	$T_{op}$	-55 to +200	$^\circ\text{C}$	Note 2
Storage Temperature Range	$T_{stg}$	-65 to +200	$^\circ\text{C}$	Note 2
Soldering Temperature For FP For TO-78 For CCP	$T_{sol}$	+265 +260 +245	$^\circ\text{C}$	Note 3 Note 3 Note 4

**NOTES:**

1. Thermal Resistance, Junction-to-Case only applies to TO-78 packaged Variants.
2. For Variants with tin-lead plating or hot solder dip lead finish all testing, and any handling, performed at  $T_{amb} > +125^\circ\text{C}$  shall be carried out in a 100% inert atmosphere.
3. Duration 10 seconds maximum at a distance of not less than 1.5mm from the device body and the same lead shall not be resoldered until 3 minutes have elapsed.
4. Duration 5 seconds maximum and the same terminal shall not be resoldered until 3 minutes have elapsed.

1.6 PHYSICAL DIMENSIONS AND TERMINAL IDENTIFICATION

1.6.1 Metal Can Package (TO-78) - 6 lead

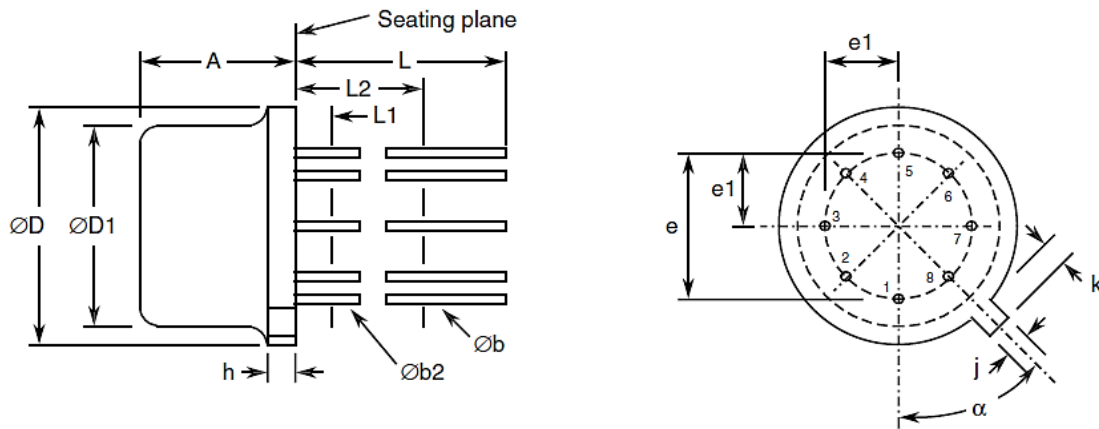

Symbols	Dimensions mm		Notes
	Min	Max	
A	4.19	4.7	
$\varnothing b$	0.406	0.533	2, 3
$\varnothing b2$	0.406	0.483	2, 3
$\varnothing D$	8.51	9.4	
$\varnothing D1$	7.75	8.51	
e	5.08 BSC		4
e1	2.54 BSC		4
h	-	1.02	
j	0.711	0.864	
k	0.737	1.14	5
L	12.7	-	2
L1	-	1.27	3
L2	6.35	-	3
$\alpha$	45° BSC		1, 4, 6

**NOTES:**

- Terminal identification is specified by reference to the tab position where lead 1 = collector 1, lead 2 = base 1, lead 3 = emitter 1, lead 5 = emitter 2, lead 6 = base 2 and lead 7 = collector 2. Lead numbers 4 and 8 are not present on the actual package; they are shown in the drawing for information only.
- Applies to all leads.
- $\varnothing b2$  applies between L1 and L2.  $\varnothing b$  applies between L2 and 12.7mm from the seating plane. Diameter is uncontrolled within L1 and beyond 12.7mm from the seating plane.
- Leads having maximum diameter 0.483mm measured in the gauging plane 1.37 (+0.025, -0) mm below the seating plane of the device shall be within 0.178mm of their true position relative to a maximum-width-tab.
- Measured from the maximum diameter of the actual device.



6. Tab centreline.

1.6.2 Chip Carrier Package (CCP) - 6 terminal

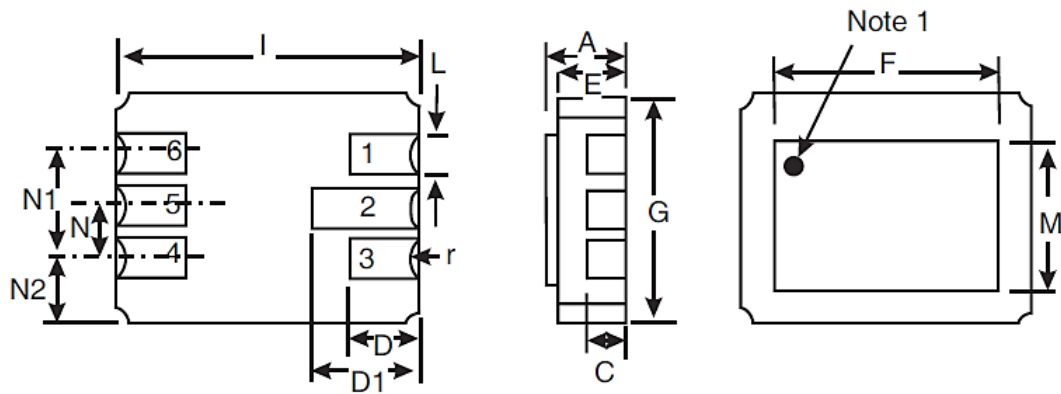

Symbols	Dimensions mm		Notes
	Min	Max	
A	1.53	1.96	
C	0.89 TYPICAL		2
D	1.52	1.78	
D1	2.08	2.49	
E	1.24	1.55	
F	5.76	5.92	
G	4.19	4.45	
I	6.1	6.35	
L	0.55	0.71	2
M	3.86	4.01	
N	1.14	1.4	
N1	2.41	2.67	
N2	0.89 TYPICAL		
r	0.23 TYPICAL		2

**NOTES:**

- Terminal identification is specified, when viewing the top side of the package, by reference to a black ink dot adjacent to terminal 1 = base 2. Terminal 2 = collector 2, terminal 3 = emitter 2, terminal 4 = emitter 1, terminal 5 = collector 1 and terminal 6 = base 1.
- Applies to all terminals.

1.6.3 Flat package (FP) – 8 Pin

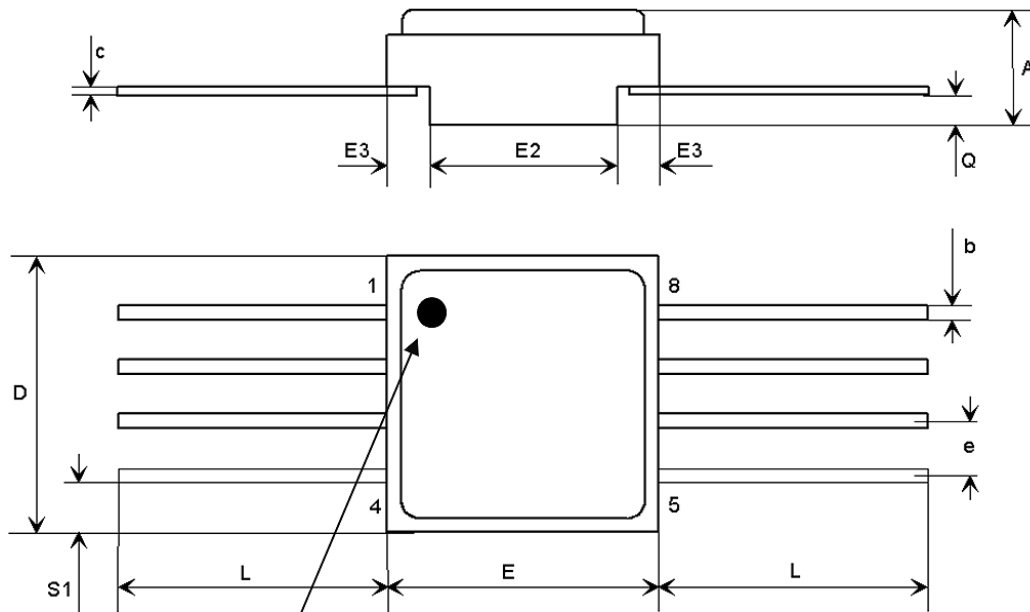

Note 1

Symbols	Dimensions mm		Notes
	Min	Max	
A	2.24	2.64	
b	0.38	0.48	2
c	0.10	0.16	2
D	6.35	6.61	
E	6.35	6.61	
E2	4.32	4.58	
E3	0.88	1.14	
e	1.27 TYPICAL		4
L	3 TYPICAL		2
Q	0.66	0.92	
S1	0.92	1.32	3

**NOTES:**

- Terminal identification is specified, when viewing the top side of the package, by reference to a black ink dot adjacent to terminal 1 = collector 1, terminal 2 = base 1, terminal 3 = emitter 1, terminal 6 = emitter 2 terminal 7 = base 2, terminal 8 = collector 2, terminals 4 and 5 are connected to seal ring and lid.
- Applies to all pins.
- 4 places.
- 6 places.

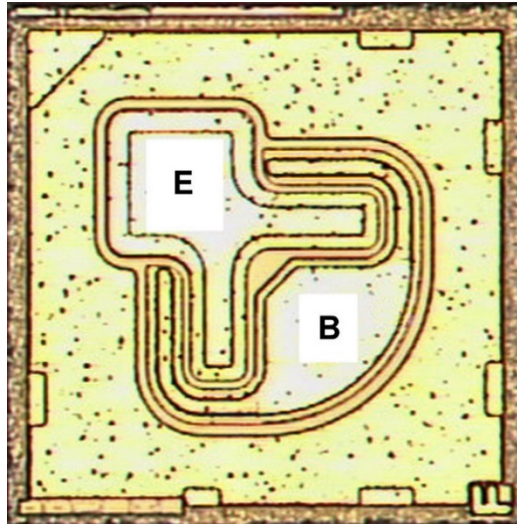
1.6.4 Die (Variant 12)Single Transistor Die Shown**NOTES:**

1. Variant 12 shall be ordered, tested and delivered in matched pairs. For delivery, each matched pair shall be identifiable by their location within the primary package.
2. Die materials and dimensions:
  - Die substrate: Silicon
  - Die length: 660  $\mu\text{m}$
  - Die width: 660  $\mu\text{m}$
  - Die thickness: 230  $\pm 25\mu\text{m}$
  - Top Glassivation:
    - P-Vapox with thickness 720  $\pm 80\text{nm}$  and
    - Nitride with thickness 540  $\pm 60\text{nm}$
  - Top metallisation: Al/Si (1%) with thickness: 1.9  $\pm 0.1\mu\text{m}$  (Typ.)
  - Backside metallisation: Au with thickness: 1.485  $\pm 0.165\mu\text{m}$
  - Emitter pad dimensions: 90  $\times$  90  $\mu\text{m}$
  - Base pad dimensions: 109  $\times$  109  $\mu\text{m}$
3. Terminal identification: B = Base, E = Emitter
4. Bias details: backside contact = Collector

1.7 FUNCTIONAL DIAGRAM

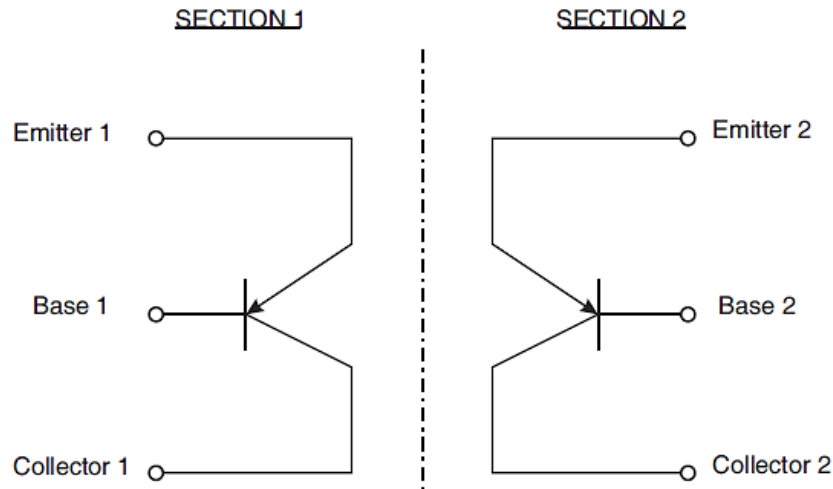

**NOTES:**

1. For TO-78 (Variants 01, 02, 05), the case is not connected to any lead.
2. For CCP (Variants 07, 09), the lid is not connected to any terminal.
3. For FP (Variants 10, 11), the seal ring and the lid are connected to terminals 4 and 5.
4. For Die (Variant 12), each Section as shown is a single die of each matched pair.

1.8 MATERIALS AND FINISHES

1.8.1 Materials and Finishes of Packaged Components

For Variants 01, 02, 05, 07, 09, 10 and 11, the materials and finishes shall be as follows:

- (a) Case  
For the metal can package the case shall be hermetically sealed and have a metal body with hard glass seals.  
For the chip carrier package and the flat package, the case shall be hermetically sealed and have a ceramic body with a Kovar lid.
- (b) Leads/Terminals  
As specified in Para. 1.4.2, Component Type Variants.

1.8.2 Materials and Finishes of Die Components

For Variant 12, the materials and finishes shall be as specified in Para. 1.6.4.

**2 REQUIREMENTS**

2.1 GENERAL

The complete requirements for procurement of the components specified herein are as stated in this specification and the ESCC Generic Specification. Permitted deviations from the Generic Specification, applicable to this specification only, are listed below.

Permitted deviations from the Generic Specification and this Detail Specification, formally agreed with specific Manufacturers on the basis that the alternative requirements are equivalent to the ESCC requirement and do not affect the component's reliability, are listed in the appendices attached to this specification.

2.1.1 Deviations from the Generic Specification

2.1.1.1 *Deviation from Production Control – Chart F2*

Special in-process controls – assembly of the packaged test subplot: For Variant 12, each packaged test subplot sample shall contain two dice in a matched pair.

For procurement, the quantity of matched pairs of dice to be assembled, n, shall be selected at the Manufacturer’s discretion from one of the four specified sampling plans (a), (b), (c) or (d).

For qualification and maintenance of qualification, the quantity of matched pairs of dice to be assembled, n, shall be selected at the Manufacturer’s discretion from one of the specified sampling plans (c) or (d).

2.2 MARKING

The marking shall be in accordance with the requirements of ESCC Basic Specification No. 21700 and as follows.

The information to be marked on the component or its primary package shall be:

- (a) Terminal identification (see Para. 1.6; applies to CCP and FP packages only).
- (b) The ESCC qualified components symbol (for ESCC qualified components only).
- (c) The ESCC Component Number (see Para. 1.4.1).
- (d) Traceability information.

2.3 TERMINAL STRENGTH

The test conditions for terminal strength, tested as specified in the ESCC Generic Specification, shall be as follows:

- For TO-78, Test Condition: E, lead fatigue.
- For FP, Test Condition: E, lead fatigue. The applied weight shall be 3 ounces (85g), with three bends of 15°.

2.4 ELECTRICAL MEASUREMENTS AT ROOM, HIGH AND LOW TEMPERATURES

Electrical measurements shall be performed at room, high and low temperatures.

2.4.1 Room Temperature Electrical Measurements

The measurements shall be performed at  $T_{amb} = +22 \pm 3^{\circ}C$ .

Characteristics	Symbols	MIL-STD-750 Test Method	Test Conditions	Limits		Units
				Min	Max	
Collector-Base Breakdown Voltage	$V_{(BR)CBO}$	3001	$I_C = -10\mu A$ , Bias condition D	-60	-	V
Collector-Emitter Breakdown Voltage	$V_{(BR)CEO}$	3011	$I_C = -10mA$ , Bias condition D, Note 1	-60	-	V
Emitter-Base Breakdown Voltage	$V_{(BR)EBO}$	3026	$I_E = -10\mu A$ , Bias condition D	-5	-	V
Collector-Base Cut-off Current	$I_{CBO}$	3036	$V_{CB} = -50V$ , Bias condition D	-	-10	nA

Characteristics	Symbols	MIL-STD-750 Test Method	Test Conditions	Limits		Units
				Min	Max	
Emitter-Base Cut-off Current	$I_{EBO}$	3061	$V_{EB} = -4V$ , Bias condition D	-	-20	nA
Collector-Emitter Saturation Voltage	$V_{CE(sat)1}$	3071	$I_C = -100\mu A$ $I_B = -10\mu A$ Note 1	-	-200	mV
	$V_{CE(sat)2}$	3071	$I_C = -1mA$ $I_B = -100\mu A$ Note 1	-	-250	mV
Base-Emitter Saturation Voltage	$V_{BE(sat)1}$	3066	$I_C = -100\mu A$ $I_B = -10\mu A$ Test Condition A Note 1	-	-700	mV
	$V_{BE(sat)2}$	3066	$I_C = -1mA$ $I_B = -100\mu A$ Test Condition A Note 1	-	-800	mV
Forward-Current Transfer Ratio	$h_{FE1}$	3076	$V_{CE} = -5V$ ; $I_C = -10\mu A$	100	-	-
	$h_{FE2}$	3076	$V_{CE} = -5V$ ; $I_C = -100\mu A$	150	450	-
	$h_{FE3}$	3076	$V_{CE} = -5V$ ; $I_C = -500\mu A$	150	450	-
	$h_{FE4}$	3076	$V_{CE} = -5V$ ; $I_C = -1mA$	150	450	-
	$h_{FE5}$	3076	$V_{CE} = -5V$ ; $I_C = -10mA$	125	-	-
Forward-Current Transfer Ratio Comparison	$h_{FE2-1}/$ $h_{FE2-2}$	3076	$V_{CE} = -5V$ ; $I_C = -100\mu A$	0.9	1.1	-
Base-Emitter Voltage Differential	$ V_{BE1}-$ $V_{BE2} 1$	3066	$I_C = -10\mu A$ $V_{CE} = -5V$ Test Condition B Note 2	-	5	mV
	$ V_{BE1}-$ $V_{BE2} 2$	3066	$I_C = -100\mu A$ $V_{CE} = -5V$ Test Condition B Note 2	-	3	mV
	$ V_{BE1}-$ $V_{BE2} 3$	3066	$I_C = -10mA$ $V_{CE} = -5V$ Test Condition B Note 2	-	5	mV
Leakage Current Between Sections	$I_{LS(e-e)}$	-	-50V to Emitter 2 0V to Emitter 1	-	5	$\mu A$
	$I_{LS(b-b)}$	-	-50V to Base 2 0V to Base 1	-	5	$\mu A$
	$I_{LS(c-c)}$	-	-50V to Collector 2 0V to Collector 1	-	5	$\mu A$
Current Gain Bandwidth Product	$f_T$	3206	$V_{CE} = -5V$ , $I_C = -1mA$ $f = 100MHz$ Notes 3, 4	80	500	MHz

Characteristics	Symbols	MIL-STD-750 Test Method	Test Conditions	Limits		Units
				Min	Max	
Small-Signal Short-Circuit Forward-Current Transfer Ratio	$h_{fe}$	3206	$I_C = -1\text{mA}$ , $V_{CE} = -10\text{V}$ $f = 1\text{kHz}$ Notes 3, 4	150	600	-
Spot Noise Figure	NF1	3246	$V_{CE} = -5\text{V}$ $I_C = -200\mu\text{A}$ $R_s = 2\text{k}\Omega$ $f = 100\text{Hz}$ $\text{BW} = 20\text{Hz}$ Notes 3, 4	-	7	dB
	NF2	3246	$V_{CE} = -5\text{V}$ $I_C = -200\mu\text{A}$ $R_s = 2\text{k}\Omega$ $f = 1\text{kHz}$ $\text{BW} = 200\text{Hz}$ Notes 3, 4	-	3	dB
Wide-Band Noise Figure	$\text{NF}_w$	3246	$V_{CE} = -5\text{V}$ $I_C = -200\mu\text{A}$ $R_s = 2\text{k}\Omega$ $10\text{Hz} \leq f \leq 15.7\text{kHz}$ Notes 3, 4	-	3.5	dB
Output Capacitance	$C_{obo}$	3236	$V_{CB} = -5\text{V}$ , $I_E = 0\text{A}$ $100\text{kHz} \leq f \leq 1\text{MHz}$ Notes 3, 4	-	6	pF
Input Capacitance	$C_{ibo}$	3240	$V_{EB} = -500\text{mV}$ , $I_C = 0\text{A}$ $100\text{kHz} \leq f \leq 1\text{MHz}$ Notes 3, 4	-	15	pF
Small-Signal Input Impedance	$h_{ie}$	3201	$V_{CE} = -10\text{V}$ $I_C = -1\text{mA}$ $f = 1\text{kHz}$ Notes 3, 4	3	30	k $\Omega$

**NOTES:**

1. Pulsed measurement: Pulse Width  $\leq 300\mu\text{s}$ , Duty Cycle  $\leq 2\%$ .
2. Any device whose measurement values exceed the specified limits shall be removed from the lot, but only count for PDA when such values exceed twice the specified limits (i.e.  $> 10\text{mV}$  or  $> 6\text{mV}$ ).
3. For Variants 01, 02, 05, 07, 09, 10 and 11, all AC characteristics read and record measurements shall be performed on a sample of 32 components with 0 failures allowed. Alternatively a 100% inspection may be performed.
4. For Variant 12, all AC characteristics read and record measurements shall be performed on either a sample of 32 matched pairs (64 dice) or 100% of the Packaged Test Sublot, whichever is less, with 0 failures allowed.

2.4.2 High and Low Temperatures Electrical Measurements

Characteristics	Symbols	MIL-STD-750 Test Method	Test Conditions Note 1	Limits		Units
				Min	Max	
Collector-Base Cut-off Current	I <sub>CBO</sub>	3036	T <sub>amb</sub> = +150 (+0 -5)°C V <sub>CB</sub> = -50V, Bias Condition D	-	-10	μA
Forward-Current Transfer Ratio 2	h <sub>FE2</sub>	3076	T <sub>amb</sub> = -55 (+5 -0)°C V <sub>CE</sub> = -5V I <sub>C</sub> = -100μA	60	-	-
Forward-Current Transfer Ratio Comparison	h <sub>FE2-1</sub> /h <sub>FE2-2</sub>	3076	T <sub>amb</sub> = -55 to +125°C V <sub>CE</sub> = -5V, I <sub>C</sub> = -100μA	0.85	1.18	-
Base-Emitter Voltage Differential Change	$ \Delta(V_{BE1} - V_{BE2})\Delta T_{amb} 1$	3066	T <sub>amb</sub> = -55 (+5 -0)°C to +25 ±3°C V <sub>CE</sub> = -5V I <sub>C</sub> = -100μA Test condition B	-	800	μV
	$ \Delta(V_{BE1} - V_{BE2})\Delta T_{amb} 2$	3066	T <sub>amb</sub> = +25 ±3°C to +125 (+0 -5) °C V <sub>CE</sub> = -5V I <sub>C</sub> = -100μA Test condition B	-	1000	μV

**NOTES:**

1. Measurements shall be performed on a sample basis as specified in the Generic Specification.

2.5 PARAMETER DRIFT VALUES

Unless otherwise specified, the measurements shall be performed at T<sub>amb</sub> = +22 ±3°C.

The test methods and test conditions shall be as per the corresponding test defined in Para. 2.4.1, Room Temperature Electrical Measurements.

The drift values (Δ) shall not be exceeded for each characteristic specified. The corresponding absolute limit values for each characteristic shall not be exceeded.

Characteristics	Symbols	Limits			Units
		Drift Value Δ	Absolute		
			Min	Max	
Collector-Base Cut-off Current	I <sub>CBO</sub>	±2 or (1) ±100%	-	-10	nA
Collector-Emitter Saturation Voltage 2	V <sub>CE(sat)2</sub>	±15 or (1) ±10%	-	-250	mV
Forward-Current Transfer Ratio 2	h <sub>FE2</sub>	±15%	150	450	-

**NOTES:**

1. Whichever is the greater referred to the initial value.



2.6 INTERMEDIATE AND END-POINT ELECTRICAL MEASUREMENTS

Unless otherwise specified, the measurements shall be performed at  $T_{amb} = +22 \pm 3^{\circ}\text{C}$ .

The test methods and test conditions shall be as per the corresponding test defined in either Para. 2.4.1, Room Temperature Electrical Measurements or Para. 2.4.2, High and Low Temperatures Electrical Measurements, as applicable.

The limit values for each characteristic shall not be exceeded.

Characteristics	Symbols	Limits		Units
		Min	Max	
Collector-Base Cut-off Current	$I_{CBO}$	-	-20	nA
Collector-Emitter Saturation Voltage 2	$V_{CE(sat)2}$	-	-250	mV
Forward-Current Transfer Ratio 2	$h_{FE2}$	150	450	-
Forward-Current Transfer Ratio Comparison	$h_{FE2-1}/h_{FE2-2}$	0.85	1.18	-
Base-Emitter Voltage Differential 2	$ V_{BE1}-V_{BE2} 2$	-	6	mV
Base-Emitter Voltage Differential Change (Note 1)	$ \Delta(V_{BE1}-V_{BE2})\Delta T_{amb} 1$	-	1	mV
	$ \Delta(V_{BE1}-V_{BE2})\Delta T_{amb} 2$	-	1.2	mV

**NOTES:**

1. Measured after Operating Life test only.

2.7 HIGH TEMPERATURE REVERSE BIAS BURN-IN CONDITIONS

Characteristics	Symbols	Test Conditions	Units
Ambient Temperature	$T_{amb}$	+150 (+0 -5)	$^{\circ}\text{C}$
Collector-Base Voltage (Note 1)	$V_{CB}$	-45	V
Duration	t	72 Minimum	hrs

**NOTES:**

1. On completion of High Temperature Reverse Bias Burn-in, the collector-base voltage shall continue to be applied until  $T_{case} < +30^{\circ}\text{C}$ .

2.8 POWER BURN-IN CONDITIONS

Characteristics	Symbols	Test Conditions	Units
Ambient Temperature	$T_{amb}$	+25 to +50	$^{\circ}\text{C}$
Power Dissipation (Both Sections)	$P_{totB}$	As per Para. 1.5, Maximum Ratings. Derate $P_{totB1}$ at the chosen $T_{amb}$ using the specified $R_{th(j-a)}$ .	W
Collector-Base Voltage	$V_{CB}$	-45	V

**2.9 OPERATING LIFE CONDITIONS**

The conditions shall be as specified in Para. 2.8, Power Burn-in Conditions.

**2.10 TOTAL DOSE RADIATION TESTING**

All lots shall be irradiated in accordance with ESCC Basic Specification No. [22900](#), low dose rate (window 2: 36rad(Si) to 360rad(Si) per hour).

**2.10.1 Bias Conditions and Total Dose Level for Total dose Radiation Testing**

The following bias conditions shall be used for Total Dose Radiation Testing:

Characteristics	Symbols	Test Conditions	Units
Ambient Temperature	$T_{amb}$	+20 ±5	°C
Bias Condition 1: Collector-Emitter Voltage	$V_{CES}$	≥ 80% $V_{(BR)CEO}$	V
Bias Condition 2: Collector-Emitter Voltage	$V_{CES}$	0	V

The total dose level applied shall be as specified in Para. 1.4.2 or in the Purchase Order.

2.10.2 Electrical Measurements for Radiation Testing

Prior to irradiation testing the devices shall have successfully met Room Temperature Electrical Measurements specified in Para. 2.4.1.

Unless otherwise stated the measurements shall be performed at  $T_{amb} = +22 \pm 3^{\circ}C$ .

Unless otherwise specified the test methods and test conditions shall be as per the corresponding test defined in Para. 2.4.1, Room Temperature Electrical Measurements.

The parameters to be measured during and on completion of irradiation testing are shown below.

Characteristics	Symbols	MIL-STD-750 Test Method	Test Conditions	Limits		Units
				Min	Max	
Collector-Base Breakdown Voltage	$V_{(BR)CBO}$	Para. 2.4.1	Para. 2.4.1	-60	-	V
Collector-Emitter Breakdown Voltage	$V_{(BR)CEO}$	Para. 2.4.1	Para. 2.4.1	-60	-	V
Emitter-Base Breakdown Voltage	$V_{(BR)EBO}$	Para. 2.4.1	Para. 2.4.1	-5	-	V
Collector-Base Cut-off Current	$I_{CBO}$	Para. 2.4.1	Para. 2.4.1	-	-10	nA
Emitter-Base Cut-off Current	$I_{EBO}$	Para. 2.4.1	Para. 2.4.1	-	-20	nA
Collector-Emitter Saturation Voltage	$V_{CE(sat)1}$	Para. 2.4.1	Para. 2.4.1	-	-200	mV
	$V_{CE(sat)2}$			-	-250	mV
Base-Emitter Saturation Voltage	$V_{BE(sat)1}$	Para. 2.4.1	Para. 2.4.1	-	-700	mV
	$V_{BE(sat)2}$			-	-800	mV
Forward-Current Transfer Ratio (post irradiation gain calculation) (Note 1)	$[h_{FE1}]$	3076	$V_{CE} = -5V, I_C = -10\mu A$	[50]	-	-
	$[h_{FE2}]$		$V_{CE} = -5V, I_C = -100\mu A$	[75]	450	-
	$[h_{FE3}]$		$V_{CE} = -5V, I_C = -500\mu A$	[75]	450	-
	$[h_{FE4}]$		$V_{CE} = -5V, I_C = -1mA$	[75]	450	-
	$[h_{FE5}]$		$V_{CE} = -5V, I_C = -10mA$	[65]	-	-

**NOTES:**

1. The post-irradiation gain calculation of  $[h_{FE}]$ , made using  $h_{FE}$  measurements from prior to and on completion of irradiation testing and after each annealing step if any, shall be as specified in [MIL-STD-750 Method 1019](#).

**APPENDIX 'A'**  
**AGREED DEVIATIONS FOR STMICROELECTRONICS (F)**

ITEMS AFFECTED	DESCRIPTION OF DEVIATIONS
Para. 2.1.1, Deviations from the Generic Specification: Para. 8, Test Methods and Procedures	For qualification and qualification maintenance, or procurement of qualified or unqualified components, the following replacement test method specifications shall be used instead of the following ESCC Basic Specifications: <ul style="list-style-type: none"> <li>• No. 20400, Internal Visual Inspection: replaced by <a href="#">MIL-STD-750 Test Method 2072</a>.</li> <li>• No. 20500, External Visual Inspection: replaced by <a href="#">MIL-STD-750 Test Method 2071</a>.</li> <li>• No. 20900, Radiographic Inspection of Electronic Components: replaced by <a href="#">MIL-STD-750 Test Method 2076</a>.</li> </ul>
Para. 2.1.1.1, Deviations from the Generic Specification: Production Control - Chart F2	Special In-Process Controls - Internal Visual Inspection. For CCP packages the criteria specified for voids in the fillet and minimum die mounting material around the visible die perimeter for die mounting defects may be omitted providing that a radiographic inspection to verify the die-attach process is performed on a sample basis in accordance with STMicroelectronics procedure 0076637.
Para. 2.1.1, Deviations from the Generic Specification: Screening Tests - Chart F3	Solderability is not applicable unless specifically stipulated in the Purchase Order.
Para. 2.4.1, Room Temperature Electrical Measurements	All AC characteristics (Para. 2.4.1, Notes 2 and 3) may be considered guaranteed but not tested if successful pilot lot testing has been performed on the wafer lot which includes AC characteristic measurements per the Detail Specification.  A summary of the pilot lot testing shall be provided if required by the Purchase Order.
Para. 2.4.2, High and Low Temperatures Electrical Measurements	All characteristics specified may be considered guaranteed but not tested if successful pilot lot testing has been performed on the wafer lot which includes characteristic measurements at high and low temperatures per the Detail Specification.  A summary of the pilot lot testing shall be provided if required by the Purchase Order.