



**RELAY, ELECTROMAGNETIC, LATCHING,
28VDC, 10A, 2PDT**

ESCC Detail Specification No. 3602/001

Issue 5	June 2021
---------	-----------



LEGAL DISCLAIMER AND COPYRIGHT

European Space Agency, Copyright © 2021. All rights reserved.

The European Space Agency disclaims any liability or responsibility, to any person or entity, with respect to any loss or damage caused, or alleged to be caused, directly or indirectly by the use and application of this ESCC publication.

This publication, without the prior permission of the European Space Agency and provided that it is not used for a commercial purpose, may be:

- copied in whole, in any medium, without alteration or modification.
- copied in part, in any medium, provided that the ESCC document identification, comprising the ESCC symbol, document number and document issue, is removed.

DOCUMENTATION CHANGE NOTICE

(Refer to <https://escies.org> for ESCC DCR content)

DCR No.	CHANGE DESCRIPTION
1424	Specification updated to incorporate changes per DCR.

TABLE OF CONTENTS

1	GENERAL	5
1.1	SCOPE	5
1.2	APPLICABLE DOCUMENTS	5
1.3	TERMS, DEFINITIONS, ABBREVIATIONS, SYMBOLS AND UNITS	5
1.4	THE ESCC COMPONENT NUMBER AND COMPONENT TYPE VARIANTS	5
1.4.1	The ESCC Component Number	5
1.4.1.1	Characteristics and/or Ratings Codes	5
1.4.2	Component Type Variants and Range of Components	6
1.5	MAXIMUM RATINGS	7
1.6	PHYSICAL DIMENSIONS AND TERMINAL IDENTIFICATION	8
1.6.1	Raised Vertical Flange Mount and Solder Pin Terminals (Variant 03)	8
1.6.2	Raised Vertical Flange Mount and Solder Hook Terminals (Variant 04)	9
1.6.3	Horizontal Flange Mount and Solder Pin Terminals (Variant 05)	10
1.6.4	Horizontal Flange Mount and Solder Hook Terminals (Variant 06)	11
1.6.5	Raised Vertical Flange Mount and Solder Pin Terminals with Polarizing Pin (Variant 08)	12
1.6.6	Horizontal Flange Mount and Solder Pin Terminals with Polarizing Pin (Variant 09)	13
1.7	FUNCTIONAL DIAGRAM	14
1.8	MATERIALS AND FINISHES	14
1.8.1	Case	14
1.8.2	Terminals	14
2	REQUIREMENTS	14
2.1	GENERAL	14
2.1.1	Deviations from the Generic Specification	14
2.2	MARKING	15
2.3	TERMINAL STRENGTH	15
2.4	ELECTRICAL MEASUREMENTS AT ROOM, HIGH AND LOW TEMPERATURES	15
2.4.1	Room Temperature Electrical Measurements	15
2.4.2	High and Low Temperatures Electrical Measurements	16
2.4.3	Notes to Electrical Measurements Tables	16
2.5	PARAMETER DRIFT VALUES	17
2.6	INTERMEDIATE AND END-POINT ELECTRICAL MEASUREMENTS	17
2.7	RUN-IN CONDITIONS	21
	APPENDIX A	22

1 GENERAL

1.1 SCOPE

This specification details the ratings, physical and electrical characteristics, and test and inspection data for the component type variants and/or the range of components specified below. It supplements the requirements of, and shall be read in conjunction with, the ESCC Generic Specification listed under Applicable Documents.

1.2 APPLICABLE DOCUMENTS

The following documents form part of this specification and shall be read in conjunction with it:

- (a) ESCC Generic Specification No. [3602](#).

1.3 TERMS, DEFINITIONS, ABBREVIATIONS, SYMBOLS AND UNITS

For the purpose of this specification, the terms, definitions, abbreviations, symbols and units specified in ESCC Basic Specification No. [21300](#) shall apply.

1.4 THE ESCC COMPONENT NUMBER AND COMPONENT TYPE VARIANTS

1.4.1 The ESCC Component Number

The ESCC Component Number shall be constituted as follows:

Example: 36020010328V

- Detail Specification Reference: 3602001
- Component Type Variant Number: 03 (as required)
- Characteristic code: Rated Coil Voltage (28Vdc): 28V (as required)

1.4.1.1 *Characteristics and/or Ratings Codes*

Characteristics and/or ratings to be codified as part of the ESCC Component Number shall be as follows:

- (a) Rated Coil Voltage expressed by means of the following codes:

Rated Coil Voltage (Vdc)	Code
28	28V
12	12V

1.4.2 Component Type Variants and Range of Components

The component type variants and range of components applicable to this specification are as follows:

Variant Number	Case and Terminal Description (Note 1)	Rated Coil Voltage (Vdc)	Weight max (g)
03	Raised Vertical Flange Mount Solder Pin Terminals	28, 12	46
04	Raised Vertical Flange Mount Solder Hook Terminals	28, 12	46
05	Horizontal Flange Mount Solder Pin Terminals	28, 12	46
06	Horizontal Flange Mount Solder Hook Terminals	28, 12	46
08	Raised Vertical Flange Mount Solder Pin Terminals with Polarizing Pin	28, 12	46
09	Horizontal Flange Mount Solder Pin Terminals with Polarizing Pin	28, 12	46

NOTES:

1. See Para. 1.6.

1.5 MAXIMUM RATINGS

The maximum ratings shall not be exceeded at any time during use or storage.

Maximum ratings shall only be exceeded during testing to the extent specified in this specification and when stipulated in Test Methods and Procedures of the ESCC Generic Specification.

Characteristics	Symbols	Maximum Ratings	Units	Remarks
Coil Voltage Range	V_{CR}	26.5 to 32 11 to 14.5	Vdc	Rated Coil Voltage: 28Vdc Rated Coil Voltage: 12Vdc
Rated Resistive Load Contact Current	I_{CR}	10	A	28Vdc resistive Note 1
Rated Inductive Load Contact Current	I_{CL}	8	A	28Vdc inductive Note 1
Overload Current	$I_{OVERLOAD}$	40	A	28Vdc resistive
Operating Temperature Range	T_{op}	-65 to +125	°C	T_{amb}
Storage Temperature Range	T_{stg}	-65 to +125	°C	T_{amb}
Soldering Temperature	T_{sol}	+260	°C	Note 2

NOTES:

1. Relays should not be used in change-over mode where the potential difference between stationary contacts is greater than 10V and the switched current is greater than 100mA.
2. Duration 10 seconds maximum at a distance not less than 3mm from the device body. The same terminal shall not be resoldered until 3 minutes have elapsed.

1.6 PHYSICAL DIMENSIONS AND TERMINAL IDENTIFICATION

1.6.1 Raised Vertical Flange Mount and Solder Pin Terminals (Variant 03)

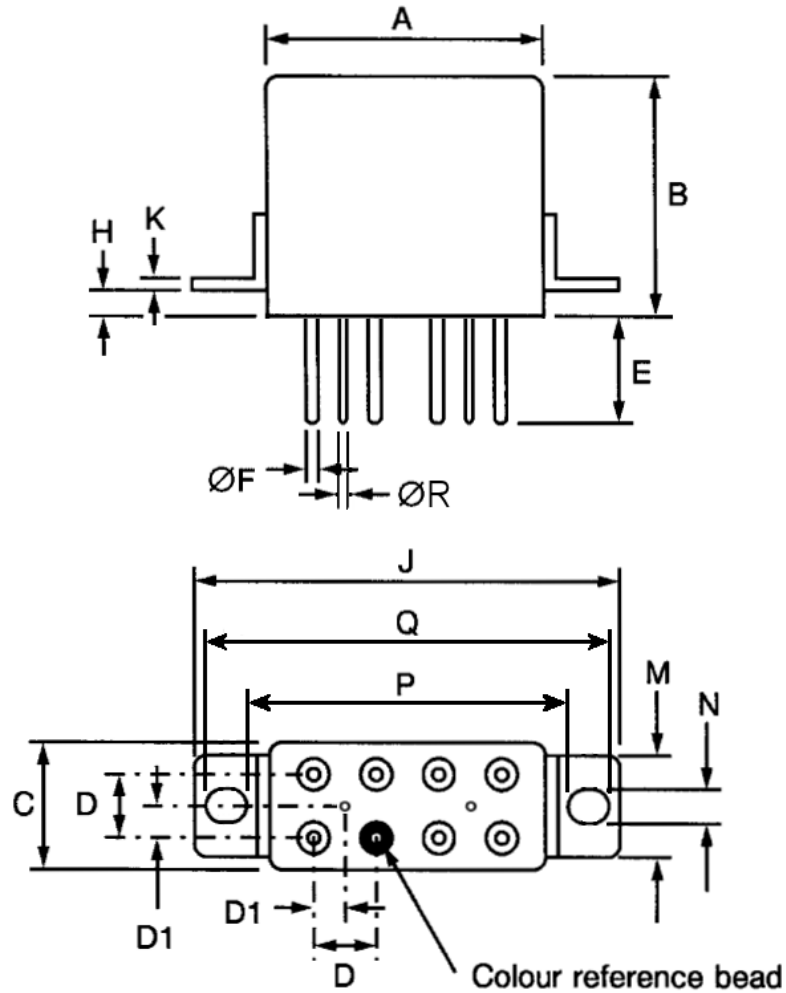

Symbols	Dimensions (mm)		Symbols	Dimensions (mm)	
	Min	Max		Min	Max
A	-	26	J	-	43.6
B	-	25.7	K	0.9	1.1
C	-	13.3	M	-	12.3
D	4.88	5.28	N	3.7	3.9
D1	2.44	2.64	P	31.15	32.15
E	6.7	7.1	Q	40	41
$\text{Ø}F$	1.55	1.62	$\text{Ø}R$	0.73	0.81
H	3.8	4.2			

NOTES:

- Terminal identification is specified by reference to the colour reference bead. See Para. 1.7.

1.6.2 Raised Vertical Flange Mount and Solder Hook Terminals (Variant 04)

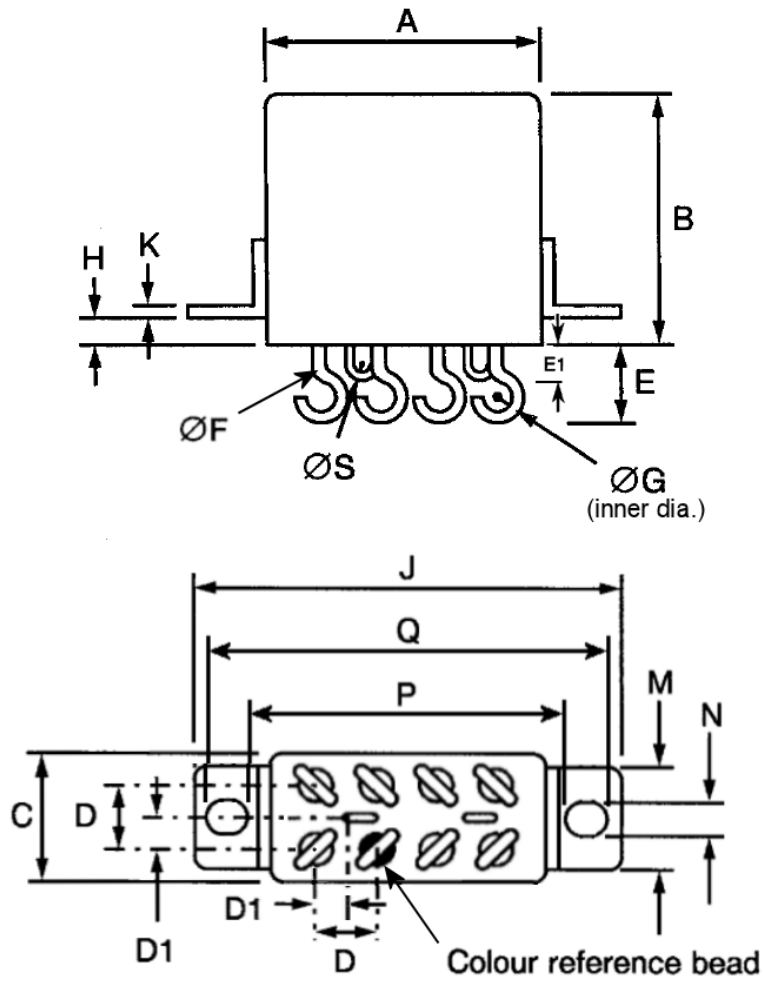

Symbols	Dimensions (mm)		Symbols	Dimensions (mm)	
	Min	Max		Min	Max
A	-	26	H	3.8	4.2
B	-	25.7	J	-	43.6
C	-	13.3	K	0.9	1.1
D	4.88	5.28	M	-	12.3
D1	2.44	2.64	N	3.7	3.9
E	-	8	P	31.15	32.15
E1	-	4.5	Q	40	41
ØF	1.54	1.62	ØS	0.73	0.81
ØG	1.75	2.25			

NOTES:

- Terminal identification is specified by reference to the colour reference bead. See Para. 1.7.

1.6.3 Horizontal Flange Mount and Solder Pin Terminals (Variant 05)

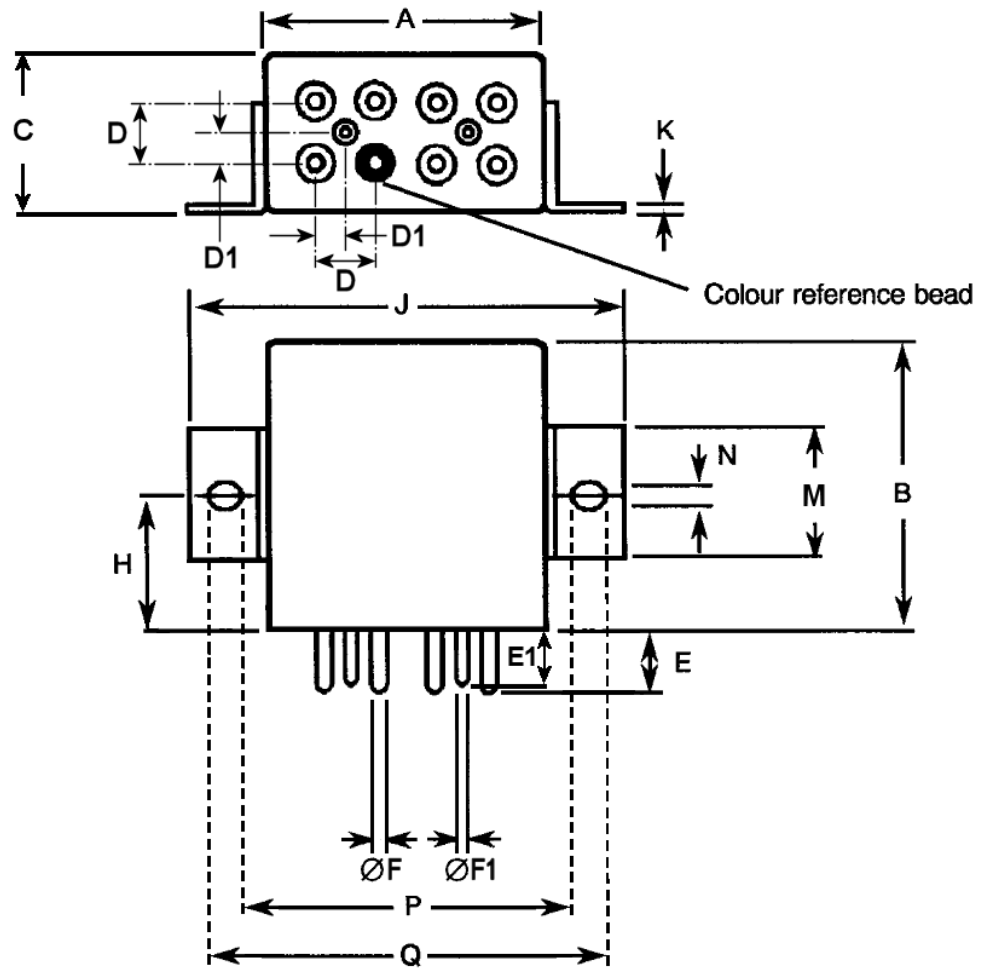

Symbols	Dimensions (mm)		Symbols	Dimensions (mm)	
	Min	Max		Min	Max
A	-	26	ØF1	0.73	0.81
B	-	25.7	H	12.5	12.9
C	-	13.3	J	-	43.6
D	4.88	5.28	K	0.9	1.1
D1	2.44	2.64	M	-	12.3
E	6.7	7.1	N	3.7	3.9
E1	6.1	6.6	P	31.15	32.15
ØF	1.55	1.62	Q	40	41

NOTES:

- Terminal identification is specified by reference to the colour reference bead. See Para. 1.7.

1.6.4 Horizontal Flange Mount and Solder Hook Terminals (Variant 06)

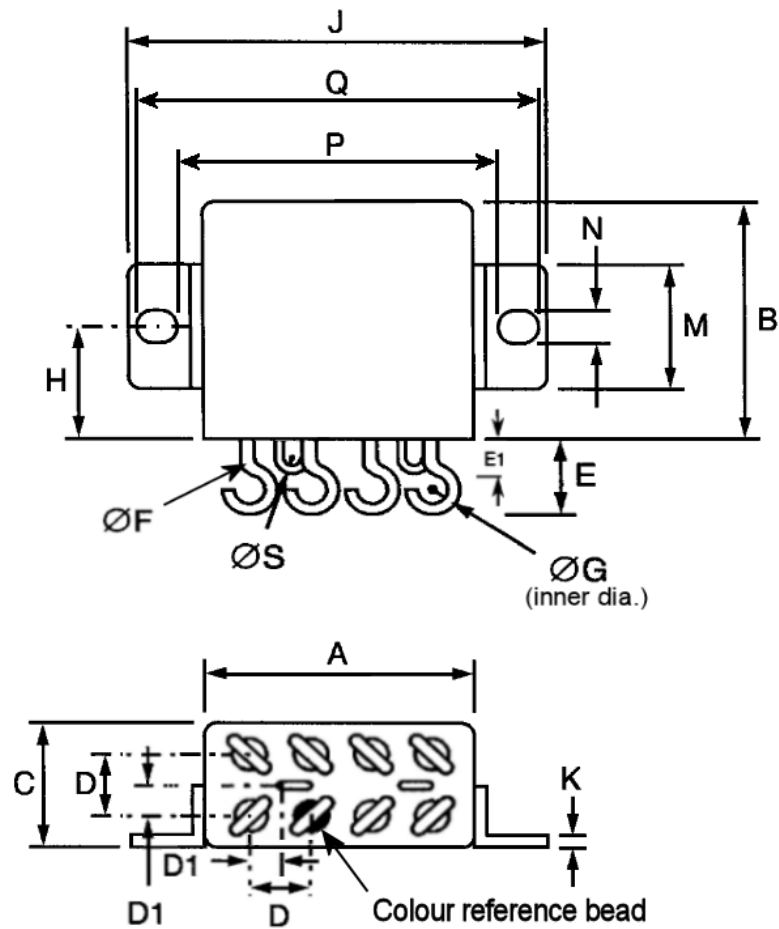

Symbols	Dimensions (mm)		Symbols	Dimensions (mm)	
	Min	Max		Min	Max
A	-	26	H	12.5	12.9
B	-	25.7	J	-	43.6
C	-	13.3	K	0.9	1.1
D	4.88	5.28	M	-	12.3
D1	2.44	2.64	N	3.7	3.9
E	-	8	P	31.15	32.15
E1	-	4.5	Q	40	41
ØF	1.54	1.62	ØS	0.73	0.81
ØG	1.75	2.25			

NOTES:

- Terminal identification is specified by reference to the colour reference bead. See Para. 1.7.

1.6.5 Raised Vertical Flange Mount and Solder Pin Terminals with Polarizing Pin (Variant 08)

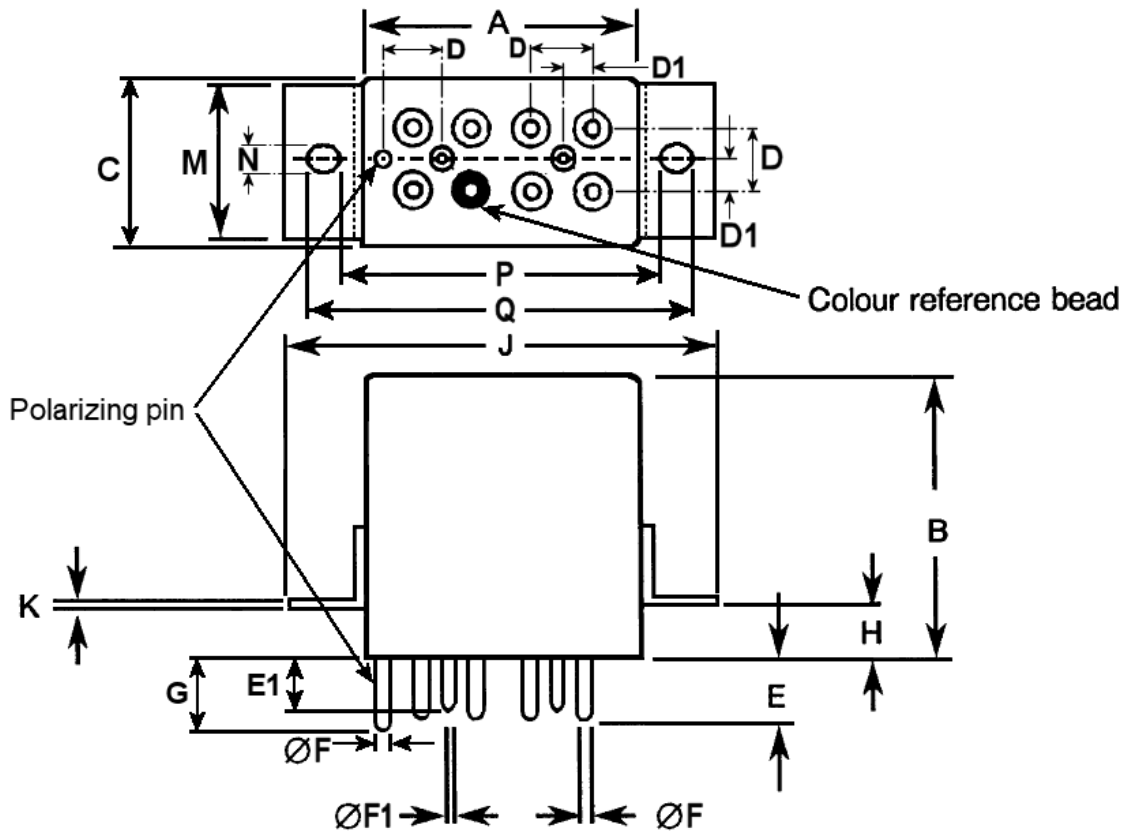

Symbols	Dimensions (mm)		Symbols	Dimensions (mm)	
	Min	Max		Min	Max
A	-	26	G	7.4	8
B	-	25.7	H	3.8	4.2
C	-	13.3	J	-	43.6
D	4.88	5.28	K	0.9	1.1
D1	2.44	2.64	M	-	12.3
E	6.7	7.1	N	3.7	3.9
E1	6.1	6.6	P	31.15	32.15
ØF	1.55	1.62	Q	40	41
ØF1	0.73	0.81			

NOTES:

- Terminal identification is specified by reference to the colour reference bead. See Para. 1.7.

1.6.6 Horizontal Flange Mount and Solder Pin Terminals with Polarizing Pin (Variant 09)

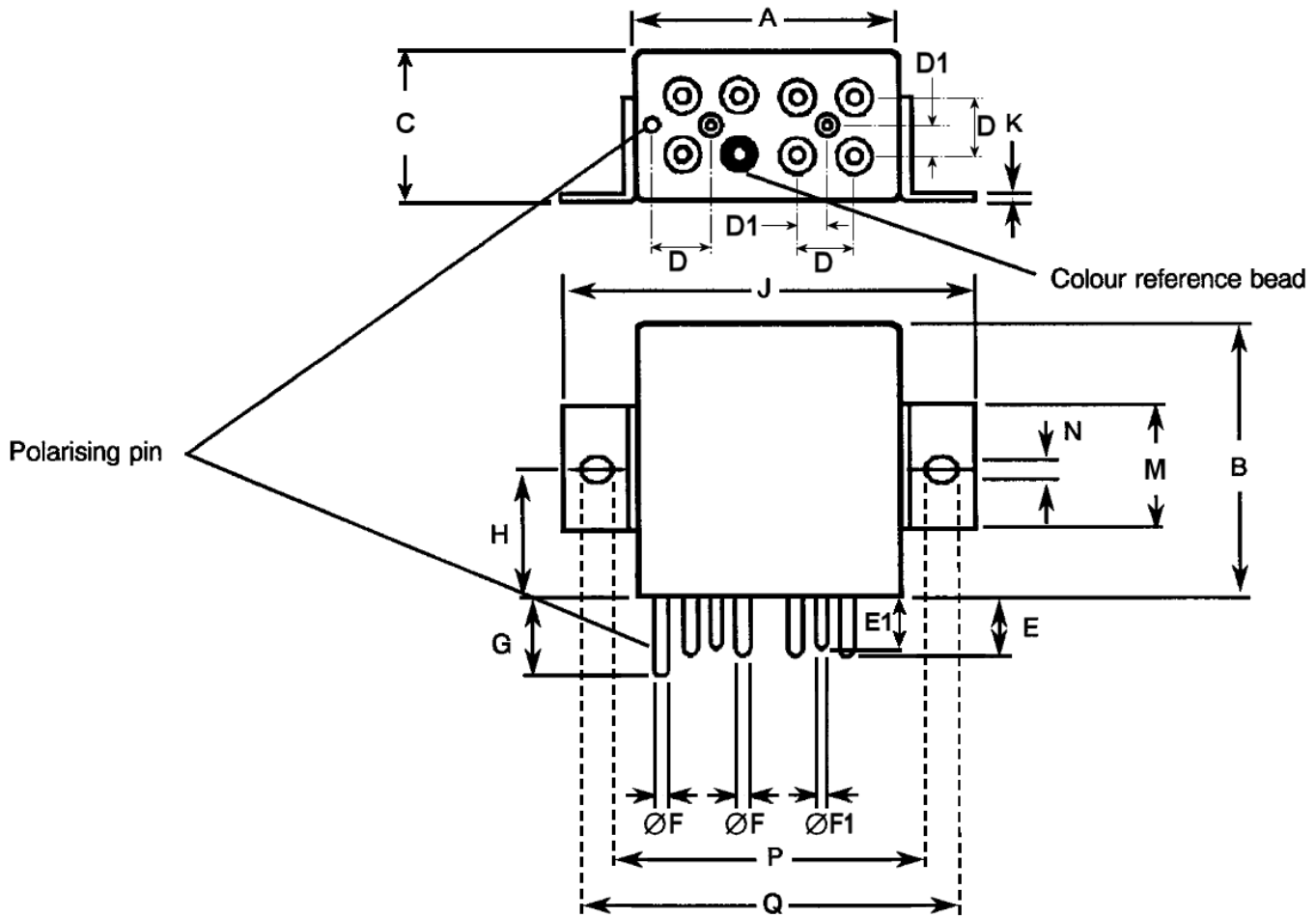

Symbols	Dimensions (mm)		Symbols	Dimensions (mm)	
	Min	Max		Min	Max
A	-	26	G	7.4	8
B	-	25.7	H	12.5	12.9
C	-	13.3	J	-	43.6
D	4.88	5.28	K	0.9	1.1
D1	2.44	2.64	M	-	12.3
E	6.7	7.1	N	3.7	3.9
E1	6.1	6.6	P	31.15	32.15
ØF	1.55	1.62	Q	40	41
ØF1	0.73	0.81			

NOTES:

1. Terminal identification is specified by reference to the colour reference bead. See Para. 1.7.

1.7 FUNCTIONAL DIAGRAM

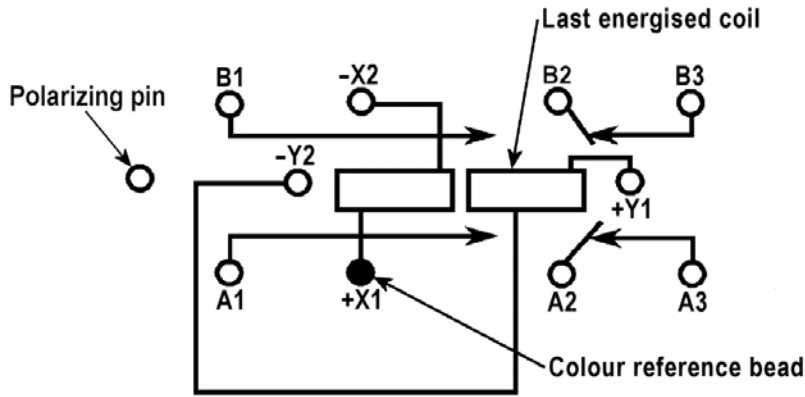

NOTES:

1. As viewed from the terminal side.
2. Individual terminal designations are for reference purposes only.
3. The polarizing pin is connected to the case (Variants 08, 09 only).

1.8 MATERIALS AND FINISHES

1.8.1 Case

Copper nickel, tin-lead alloy plated, hermetically sealed.

1.8.2 Terminals

The lead material and finish shall be type H3, H4 or H19 in accordance with the requirements of ESCC Basic Specification No. [23500](#).

2 REQUIREMENTS

2.1 GENERAL

The complete requirements for procurement of the components specified herein are as stated in this specification and the ESCC Generic Specification. Permitted deviations from the Generic Specification, applicable to this specification only, are listed below.

Permitted deviations from the Generic Specification and this Detail Specification, formally agreed with specific Manufacturers on the basis that the alternative requirements are equivalent to the ESCC requirement and do not affect the component's reliability, are listed in the appendices attached to this specification.

2.1.1 Deviations from the Generic Specification

None

2.2 MARKING

The marking shall be in accordance with the requirements of ESCC Basic Specification No. 21700 and as follows.

The information to be marked on the component shall be:

- (a) The ESCC qualified components symbol (for ESCC qualified components only).
- (b) The ESCC Component Number (see Para. 1.4.1).
- (c) Traceability information.

2.3 TERMINAL STRENGTH

The terminals of all Variants are defined as rigid.

The test conditions for Terminal Strength, tested as specified in the ESCC Generic Specification, shall be as follows:

- (a) Pull Test: Applied Force:
 - 50N for 1.6mm diameter terminals
 - 15N for 0.8mm diameter terminals

2.4 ELECTRICAL MEASUREMENTS AT ROOM, HIGH AND LOW TEMPERATURES

Electrical measurements shall be performed at room, high and low temperatures. Consolidated notes are given in Para. 2.4.3.

2.4.1 Room Temperature Electrical Measurements

The measurements shall be performed at $T_{amb} = +22 \pm 3^{\circ}C$.

Characteristics	Symbols	Test Method and Conditions	Rated Coil Voltage (Vdc)	Limits		Units
				Min	Max	
Latch Voltage	U _L	ESCC No. 3602 Note 1	28 12	8 3.6	14 6.6	V
Reset Voltage	U _R	ESCC No. 3602 Note 1	28 12	8 3.6	14 6.6	V
Latch Time	t _L	ESCC No. 3602	All	-	15	ms
Reset Time	t _R	ESCC No. 3602	All	-	15	ms
Bounce Time	t _B	ESCC No. 3602	All	-	1	ms
Insulation Resistance	R _I	ESCC No. 3602 V _{TEST} = 500Vdc	All	100	-	MΩ
Voltage Proof (Test Voltage)	VP	ESCC No. 3602 Maximum Leakage Current I _{LVP} = 1mA	All	1250 1000 (2) 350 (3)	- - -	Vrms
Voltage Proof Leakage Current	I _{LVP}	ESCC No. 3602 Note 4	All	-	1	mA
Contact Voltage Drop	V _D	ESCC No. 3602 100mA ≤ I _{TEST} ≤ 10A	All	-	0.015 x I _{TEST}	V

Characteristics	Symbols	Test Method and Conditions	Rated Coil Voltage (Vdc)	Limits		Units
				Min	Max	
Coil Resistance	R _B	ESCC No. 3602 Both coils	28	270	330	Ω
			12	54	66	

2.4.2 High and Low Temperatures Electrical Measurements

Characteristics	Symbols	Test Method and Conditions	Rated Coil Voltage (Vdc)	Limits		Units
				Min	Max	
Latch Voltage	U _L	ESCC No. 3602 T _{amb} = +125 (+0 -5)°C and -65 (+5 -0)°C Note 1	28	-	18	V
			12	-	9	
Reset Voltage	U _R	ESCC No. 3602 T _{amb} = +125 (+0 -5)°C and -65 (+5 -0)°C Note 1	28	-	18	V
			12	-	9	
Latch Time	t _L	ESCC No. 3602 T _{amb} = +125 (+0 -5)°C and -65 (+5 -0)°C	All	-	15	ms
Reset Time	t _R	ESCC No. 3602 T _{amb} = +125 (+0 -5)°C and -65 (+5 -0)°C	All	-	15	ms
Bounce Time	t _B	ESCC No. 3602 T _{amb} = +125 (+0 -5)°C and -65 (+5 -0)°C	All	-	1	ms
Insulation Resistance	R _I	ESCC No. 3602 T _{amb} = +125(+0 -5)°C V _{TEST} = 500Vdc	All	50	-	MΩ
Contact Voltage Drop	V _D	ESCC No. 3602 T _{amb} = +125 (+0 -5)°C and -65 (+5 -0)°C 100mA ≤ I _{TEST} ≤ 10A	All	-	0.015 x I _{TEST}	V

2.4.3 Notes to Electrical Measurements Tables

1. The coil voltage rise time shall be less than 0.1t_L or 0.1t_R. The coil voltage shall be maintained for a minimum duration of 10t_L or 10t_R.
2. Between coil and case.
3. Between between latch and reset coils.
4. Measured during Voltage Proof test.

2.5 PARAMETER DRIFT VALUES

Parameter Drift Values shall be measured as specified in the ESCC Generic Specification.

Unless otherwise specified, the measurements shall be performed at $T_{amb} = +22 \pm 3^{\circ}\text{C}$.

The test methods and test conditions shall be as per the corresponding test defined in Para. 2.4.1 Room Temperature Electrical Measurements.

The corresponding absolute limit values for each characteristic shall not be exceeded.

Characteristics	Symbols	Limits			Units
		Drift Value Δ	Absolute		
			Min	Max	
Latch Voltage	U_L	Note 1	Note 2	Note 2	V
Reset Voltage	U_R	Note 1	Note 2	Note 2	V

NOTES:

1. Drift Value (Δ) limits are not specified. Drift Values shall be recorded for information purposes only.
2. The limit specified in Para. 2.4.1 shall apply.

2.6 INTERMEDIATE AND END-POINT ELECTRICAL MEASUREMENTS

Unless otherwise specified, the measurements shall be performed at $T_{amb} = +22 \pm 3^{\circ}\text{C}$.

Unless otherwise specified the test methods and test conditions shall be as per the corresponding test defined in Para. 2.4.1 Room Temperature Electrical Measurements.

Test Reference per ESCC No. 3602	Characteristics	Symbols	Limits		Units
			Min	Max	
Thermal Shock	<u>During 5th Cycle</u>				
	Latch Voltage	U_L	Note 2		V
	Reset Voltage	U_R	Note 2		V
	Latch Time	t_L	Note 2		ms
	Reset Time	t_R	Note 2		ms
	<u>Final Measurements</u>				
	Voltage Proof	VP	Note 3		Vrms
Voltage Proof Leakage Current	I_{LVP}	Note 3		mA	
Low Level Sine Vibration	<u>Final Measurements</u>				
	Latch Voltage	U_L	Note 3		V
	Latch Voltage Drift	$\Delta U_L / U_L$	Note 1		%
	Reset Voltage	U_R	Note 3		V
	Reset Voltage Drift	$\Delta U_R / U_R$	Note 1		%

Test Reference per ESCC No. 3602	Characteristics	Symbols	Limits		Units
			Min	Max	
High Level Sine Vibration	<u>Final Measurements</u>				
	Latch Voltage	U_L	Note 3	V	
	Latch Voltage Drift	$\Delta U_L/U_L$	Note 1	%	
	Reset Voltage	U_R	Note 3	V	
Low Level Mechanical Shock	<u>Final Measurements</u>				
	Contact Voltage Drop	V_D	Note 3	V	
	Latch Voltage	U_L	Note 3	V	
	Latch Voltage Drift	$\Delta U_L/U_L$	Note 1	%	
	Reset Voltage	U_R	Note 3	V	
	Reset Voltage Drift	$\Delta U_R/U_R$	Note 1	%	
High Level Mechanical Shock	Voltage Proof	V_P	Note 3	Vrms	
	Voltage Proof Leakage Current	I_{LVP}	Note 3	mA	
	<u>Final Measurements</u>				
	Contact Voltage Drop	V_D	Note 3	V	
Resistance to Soldering Heat	Latch Voltage	U_L	Note 3	V	
	Latch Voltage Drift	$\Delta U_L/U_L$	Note 1	%	
	Reset Voltage	U_R	Note 3	V	
	Reset Voltage Drift	$\Delta U_R/U_R$	Note 1	%	
	Voltage Proof	V_P	Note 3	Vrms	
	Voltage Proof Leakage Current	I_{LVP}	Note 3	mA	
Resistance to Soldering Heat	<u>Final Measurements</u>				
	Insulation Resistance	R_I	Note 3	MΩ	
	Contact Voltage Drop	V_D	Note 3	V	
	Latch Voltage	U_L	Note 3	V	
	Reset Voltage	U_R	Note 3	V	
Coil Resistance		R_B	Note 3	Ω	

Test Reference per ESCC No. 3602	Characteristics	Symbols	Limits		Units
			Min	Max	
Inductive Life	<u>During Monitoring</u>				
	Contact Voltage Drop	V_D	-	2.8	V
	<u>Final Measurements</u>				
	Contact Voltage Drop	V_D	-	$0.0175 \times I_{TEST}$	V
	Insulation Resistance	R_I	50	-	MΩ
	Voltage Proof	V_P	1000 350 (4)	- -	Vrms
	Voltage Proof Leakage Current	I_{LVP}		Note 3	mA
	Latch Voltage	U_L		Note 3	V
	Latch Voltage Drift	$\Delta U_L/U_L$		Note 1	%
	Reset Voltage	U_R		Note 3	V
	Reset Voltage Drift	$\Delta U_R/U_R$		Note 1	%
	Latch Time	t_L		Note 3	ms
	Reset Time	t_R		Note 3	ms
	Bounce Time	t_B		Note 3	ms
	Coil Resistance	R_B		Note 3	Ω
Resistive Life	<u>During Monitoring</u>				
	Contact Voltage Drop	V_D	-	2.8	V
	<u>Final Measurements</u>				
	Contact Voltage Drop	V_D	-	$0.0175 \times I_{TEST}$	V
	Insulation Resistance	R_I	50	-	MΩ
	Voltage Proof	V_P	1000 350 (4)	- -	Vrms
	Voltage Proof Leakage Current	I_{LVP}		Note 3	mA
	Latch Voltage	U_L		Note 3	V
	Latch Voltage Drift	$\Delta U_L/U_L$		Note 1	%
	Reset Voltage	U_R		Note 3	V
	Reset Voltage Drift	$\Delta U_R/U_R$		Note 1	%
	Latch Time	t_L		Note 3	ms
	Reset Time	t_R		Note 3	ms
	Bounce Time	t_B		Note 3	ms
	Coil Resistance	R_B		Note 3	Ω

Test Reference per ESCC No. 3602	Characteristics	Symbols	Limits		Units
			Min	Max	
Coil Life	<u>During Step 1 of each Cycle</u>				
	Contact Voltage Drop	V _D		Note 3	V
	Coil Resistance	R _B		Note 3	Ω
	<u>During Step 3 of 1st Cycle</u>				
	Contact Voltage Drop	V _D		Note 2	V
	Latch Time	t _E		Note 2	ms
	Reset Time	t _D		Note 2	ms
	<u>During Steps 4 & 5 of 4th Cycle</u>				
	Latch Voltage	U _L		Note 2	V
	Reset Voltage	U _R		Note 2	V
	<u>Final Measurements</u>				
	Voltage Proof	VP		Note 3	Vrms
	Voltage Proof Leakage Current	I _{LVP}		Note 3	mA
	Insulation Resistance	R _I		Note 3	MΩ
	Contact Voltage Drop	V _D		Note 3	V
	Coil Resistance	R _B		Note 3	Ω
	Latch Time	t _L		Note 3	ms
	Reset Time	t _R		Note 3	ms
Bounce Time	t _B		Note 3	ms	
Intermediate Current	<u>During Monitoring</u>				
	Contact Voltage Drop:	V _D			mV
	Pole 1; Group 1, 2, 3 (10A)		-	175	
	Pole 2; Group 1 (0.5A)		-	30	
	Pole 2; Group 2 (0.3A)		-	18	
	Pole 2; Group 3 (0.1A)		-	6	
	<u>Final Measurements</u>				
	Insulation Resistance	R _I	50	-	MΩ
	Voltage Proof	VP		Note 3	Vrms
	Voltage Proof Leakage Current	I _{LVP}		Note 3	mA
	Latch Voltage	U _L		Note 3	V
	Latch Voltage Drift	ΔU _L /U _L		Note 1	%
	Reset Voltage	U _R		Note 3	V
	Reset Voltage Drift	ΔU _R /U _R		Note 1	%
	Latch Time	t _L		Note 3	ms
	Reset Time	t _R		Note 3	ms
Bounce Time	t _B		Note 3	ms	
Coil Resistance	R _B		Note 3	Ω	
Contact Voltage Drop	V _D	-	0.0175 x I _{TEST}	V	

Test Reference per ESCC No. 3602	Characteristics	Symbols	Limits		Units
			Min	Max	
Mechanical Life	<u>Final Measurements</u>				
	Contact Voltage Drop	V_D	-	$0.0175 \times I_{TEST}$	V
	Latch Voltage	U_L		Note 3	V
	Latch Voltage Drift	$\Delta U_L / U_L$		Note 1	%
	Reset Voltage	U_R		Note 3	V
	Reset Voltage Drift	$\Delta U_R / U_R$		Note 1	%
	Latch Time	t_L		Note 3	ms
	Reset Time	t_R		Note 3	ms
	Bounce Time	t_B		Note 3	ms
	Coil Resistance	R_B		Note 3	Ω
Overload	<u>During Monitoring</u>				
	Contact Voltage Drop	V_D	-	2.8	V
	<u>Final Measurements</u>				
	Contact Voltage Drop	V_D	-	$0.0175 \times I_{TEST}$	V
	Insulation Resistance	R_I	50	-	M Ω
	Voltage Proof	V_P	1000 350 (4)	- -	Vrms
	Voltage Proof Leakage Current	I_{LVP}		Note 3	mA
	Latch Voltage	U_L		Note 3	V
	Latch Voltage Drift	$\Delta U_L / U_L$		Note 1	%
	Reset Voltage	U_R		Note 3	V
	Reset Voltage Drift	$\Delta U_R / U_R$		Note 1	%
	Latch Time	t_L		Note 3	ms
	Reset Time	t_R		Note 3	ms
	Bounce Time	t_B		Note 3	ms
	Coil Resistance	R_B		Note 3	Ω

NOTES:

- Parameter Drift shall be calculated referenced to the measurement immediately prior to the test in question. An additional initial measurement may be performed prior to the test in question if considered necessary. Drift limits are not specified. Drift Values shall be recorded for information purposes only.
- The limits specified in Para. 2.4.2, as applicable to the same test temperature, shall apply.
- The limits specified in Para. 2.4.1 shall apply.
- Between between latch and reset coils.

2.7 RUN-IN CONDITIONS

The test conditions for Run-in, tested as specified in the ESCC Generic Specification, shall be as follows:

- Test Temperature: +22 ±3°C.

APPENDIX A
AGREED DEVIATIONS FOR REL STPI (F)

ITEMS AFFECTED	DESCRIPTION OF DEVIATIONS
Para. 2.1.1, Deviations from the Generic Specification: Qualification and Periodic Tests - Chart F4	Chart F4: Coil Life subgroup test sequence (under Endurance Subgroup 1): Coil Life and the subsequent tests shall only be performed for Qualification. They are not required for Periodic Testing except in the case of any significant change to the design.