



**CONTACTS, POWER, CRIMP-TYPE, SOLDER-TYPE
AND PCB-TYPE FOR 3401/001 CONNECTORS AND
MALE/FEMALE-TYPE FOR 3401/080 CONNECTOR
SAVERS**

ESCC Detail Specification No. 3401/040

Issue 6	April 2014
---------	------------



Document Custodian: European Space Agency – see <https://escies.org>

LEGAL DISCLAIMER AND COPYRIGHT

European Space Agency, Copyright © 2014. All rights reserved.

The European Space Agency disclaims any liability or responsibility, to any person or entity, with respect to any loss or damage caused, or alleged to be caused, directly or indirectly by the use and application of this ESCC publication.

This publication, without the prior permission of the European Space Agency and provided that it is not used for a commercial purpose, may be:

- copied in whole, in any medium, without alteration or modification.
- copied in part, in any medium, provided that the ESCC document identification, comprising the ESCC symbol, document number and document issue, is removed.

DOCUMENTATION CHANGE NOTICE

(Refer to <https://escies.org> for ESCC DCR content)

DCR No.	CHANGE DESCRIPTION
849	Specification upissued to incorporate editorial changes per DCR.

TABLE OF CONTENTS

1	GENERAL	6
1.1	SCOPE	6
1.2	TYPE VARIANTS	6
1.3	MAXIMUM RATINGS	6
1.4	PARAMETER DERATING INFORMATION (FIGURE 1)	6
1.5	PHYSICAL DIMENSIONS	6
2	APPLICABLE DOCUMENTS	14
3	TERMS, DEFINITIONS, ABBREVIATIONS, SYMBOLS AND UNITS	14
4	REQUIREMENTS	14
4.1	GENERAL	14
4.2	DEVIATIONS FROM GENERIC SPECIFICATION	14
4.2.1	Deviations from Special In-Process Controls	14
4.2.2	Deviations from Final Production Tests (Chart II)	14
4.2.3	Deviations from Burn-in and Electrical Measurements (Chart III)	14
4.2.4	Deviations from Qualification Tests (Chart IV)	14
4.2.5	Deviations from Lot Acceptance Tests (Chart V)	14
4.3	MECHANICAL REQUIREMENTS	15
4.3.1	Dimension Check	15
4.3.2	Weight	15
4.3.3	Contact Capability (Variants 02, 04, 06, 08, 10, 12, 14, 16, 17)	15
4.3.4	Contact Retention (in Insert)	15
4.3.5	Mating and Unmating Forces	15
4.3.6	Insert Retention (in Shell)	15
4.3.7	Jackscrew Retention	15
4.3.8	Contact Insertion and Withdrawal Forces	15
4.3.9	Engagement and Separation Forces (Variants 02, 04, 06, 08, 10, 12, 14, 16, 17)	15
4.3.10	Oversize Pin Exclusion	15
4.3.11	Probe Damage	16
4.3.12	Solderability	16
4.3.13	Joint Strength (Variants 07 to 12)	16
4.4	MATERIALS AND FINISHES	16
4.4.1	Contact Body	16
4.4.2	Magnetism Level	16
4.5	MARKING	16
4.5.1	General	16

4.5.2	The ESCC Component Number	17
4.5.3	Traceability Information	17
4.6	ELECTRICAL MEASUREMENTS	17
4.6.1	Electrical Measurements at Room Temperature	17
4.6.2	Electrical Measurements at High and Low Temperatures (Table 3)	17
4.6.3	Circuits for Electrical Measurements	17
4.7	SCREENING TESTS (TABLES 4 AND 5)	17
4.8	ENVIRONMENTAL AND ENDURANCE TESTS	17
4.8.1	Measurements and Inspections on Completion of Environmental Tests	17
4.8.2	Measurements and Inspections at Intermediate Points During Endurance Tests	18
4.8.3	Measurements and Inspections on Completion of Endurance Tests	18
4.8.4	Conditions for Operating Life Test (Part of Endurance Testing)	18
4.8.5	Electrical Circuit for Operating Life Test	18
4.8.6	Conditions for High Temperature Storage Test (Part of Endurance Testing)	18

1 GENERAL

1.1 SCOPE

This specification details the ratings, physical and electrical characteristics, test and inspection data for Contacts, Power, Crimp-type, Solder-type and PCB-type for 3401/001 Connectors and Male/Female-type for 3401/080 Connector Savers.

The specification shall be read in conjunction with:

- ESCC Generic Specification No. 3401, Connectors, Electrical, Non-Filtered, Circular and Rectangular.
- ESCC Detail Specification No. 3401/001, Connectors, Electrical, Rectangular, Non-removable Solder bucket, PCB and Wire-wrap Contacts and Removable Coaxial and Power Contacts, Based on Type D*M.
- ESCC Detail Specification No. 3401/080, Connector Savers, Electrical Rectangular, Miniature, Non-Removable Signal Contacts, and Removable Coaxial and Power Contacts.

the requirements of which are supplemented herein.

These contacts are not mounted in the connectors and are therefore delivered separately.

1.2 TYPE VARIANTS

Variants of the basic type contacts specified herein, which are covered by this specification, together with their mechanical characteristics, are given in Table 1(a).

1.3 MAXIMUM RATINGS

The maximum ratings, which shall not be exceeded at any time during use or storage, applicable to the contacts specified herein, are scheduled in Table 1(b).

1.4 PARAMETER DERATING INFORMATION (FIGURE 1)

The derating information applicable to the contacts specified herein is shown in Figure 1.

1.5 PHYSICAL DIMENSIONS

The physical dimensions of the contacts specified herein are shown in Figure 2.

TABLE 1(a) - TYPE VARIANTS

Variant	Type	Max. Weight (g)	Accepted Cable (AWG)	Rear End
01	Male	2.2	8	Solder Bucket
02	Female	1.9	8	Solder Bucket
03	Male	2.15	12	Solder Bucket
04	Female	1.19	12	Solder Bucket
05	Male	2.05	16	Solder Bucket
06	Female	1.75	16	Solder Bucket
07	Male	2.8	8	Crimp Barrel
08	Female	2.45	8	Crimp Barrel
09	Male	2.25	10	Crimp Barrel
10	Female	2	10	Crimp Barrel
11	Male	2	12-14	Crimp Barrel
12	Female	1.65	12-14	Crimp Barrel
13	Male	2.75	N.A.	Straight PCB
14	Female	1.75	N.A.	Straight PCB
15	Male	2.65	N.A.	90° PCB (Note 1)
16	Female	2.45	N.A.	90° PCB (Note 1)
17	Male/Female	2.15	N.A.	N.A.

NOTES:

1. Applicable to shell sizes E, A, B and C only.

TABLE 1(b) - MAXIMUM RATINGS

No.	Characteristics	Symbol	Maximum Rating	Unit	Remarks
1	Rated Current	I_{CR}	40	A	Note 1 Note 2
2	Operating Temperature Range	T_{op}	-55 to +125	°C	T_{amb}
3	Storage Temperature Range	T_{stg}	-55 to +125	°C	
4	Soldering Temperature	T_{sol}	+260	°C	Note 3

NOTES:

1. This is limited either by the current carrying capability of the cable to which the contact is fitted or the derating.
2. At $T_{amb} \leq +60$ °C. For derating at $T_{amb} > +60$ °C, see Figure 1.
3. 10 seconds maximum.

FIGURE 1 - PARAMETER DERATING INFORMATION

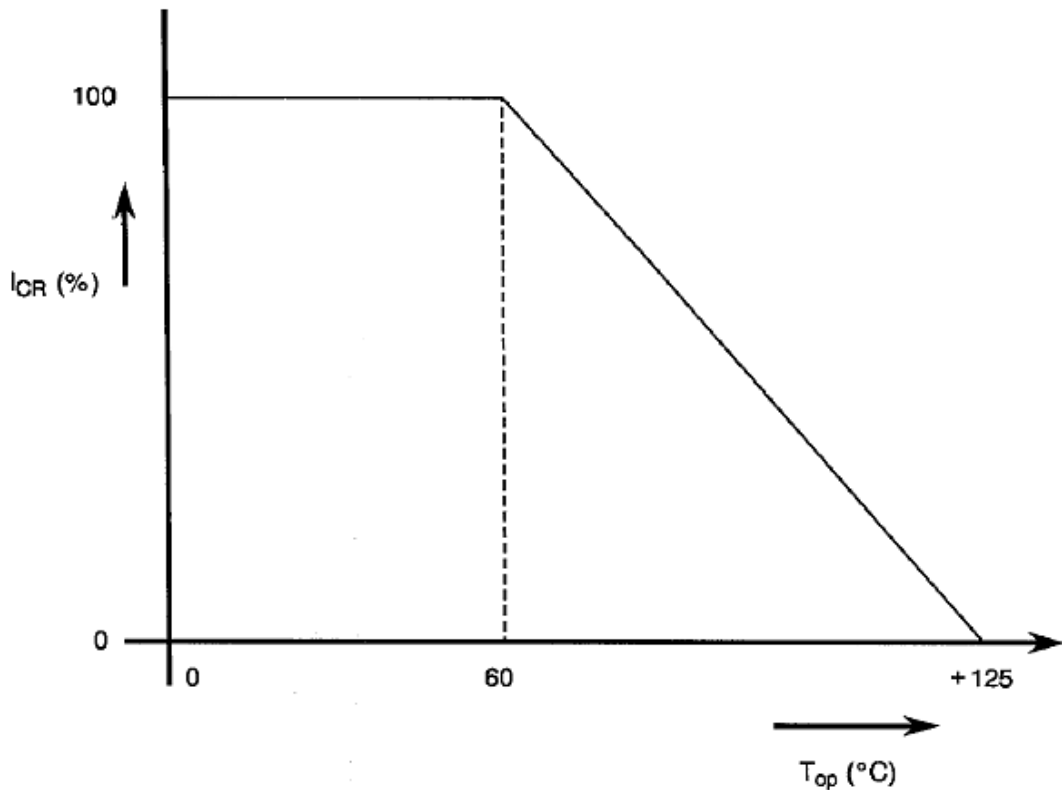

Rated Contact Current versus Temperature

FIGURE 2 - PHYSICAL DIMENSIONS

FIGURE 2(a) - SOLDER TYPE

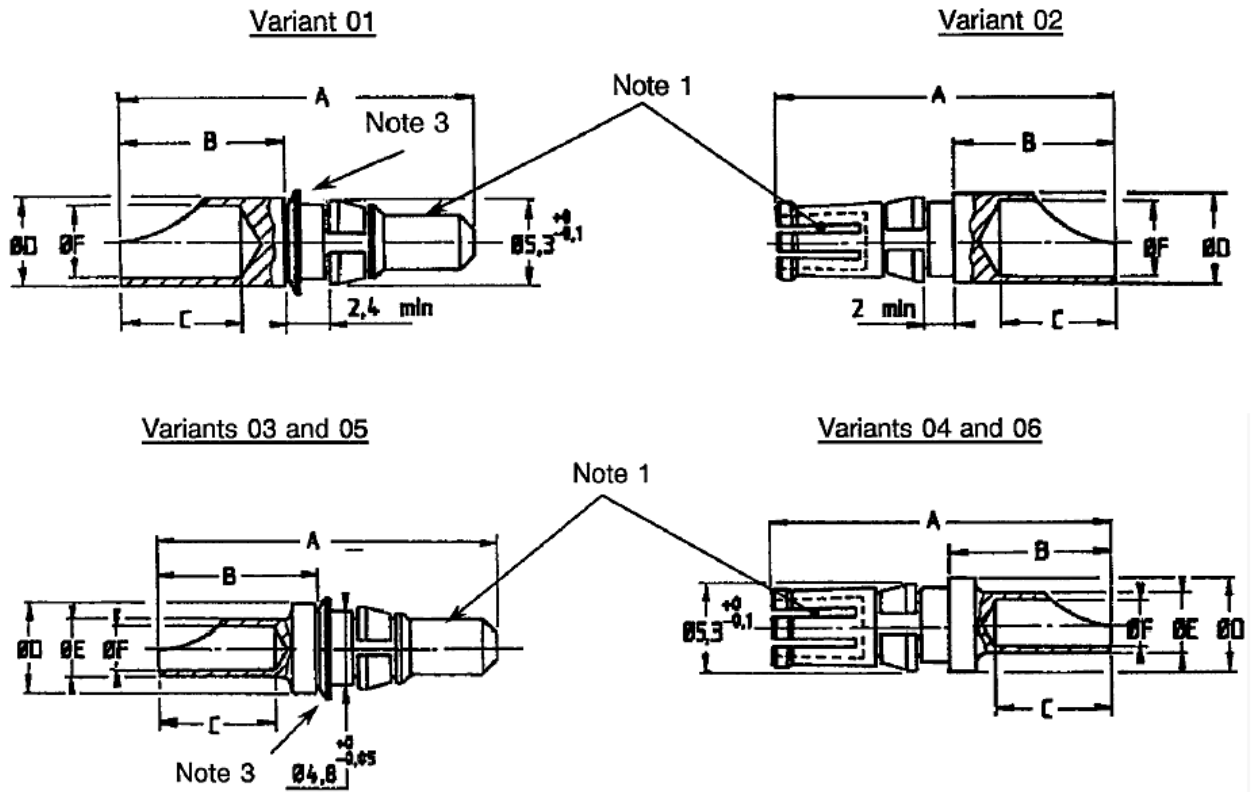

Variant (Note 2)	Type	AWG	A max.	B max.	C max.	ØD max.	ØE max.	ØF max.
01	Male	8	22.1	10.8	8.13	5.66	-	4.9
02	Female	8	21.8	10.8	8.13	5.66	-	4.9
03	Male	12	22.1	10.8	8.13	5.66	3.76	3
04	Female	12	21.8	10.8	8.13	5.66	3.76	3
05	Male	16	22.1	10.8	8.13	5.66	2.67	1.9
06	Female	16	21.8	10.8	8.13	5.66	2.67	1.9

NOTES:

1. Measurement point for plating thickness.
2. All dimensions are in millimetres.
3. Washer is optional.

FIGURE 2(b) - CRIMP TYPE

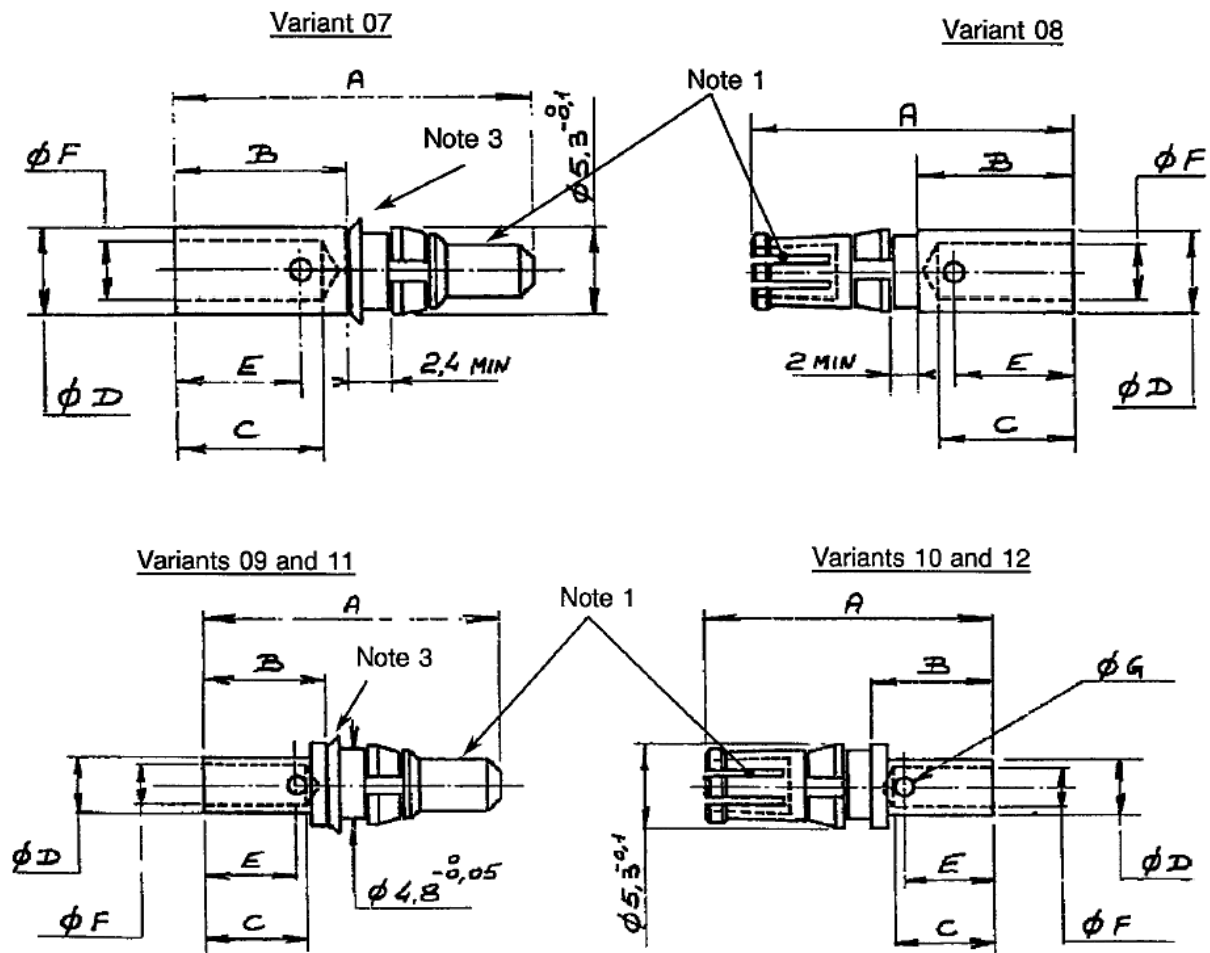

Variant (Note 2)	Type	AWG	A max.	B max.	C min.	ØD max.	E ref.	ØF min.	ØG ref.
07	Male	8	24.7	12.9	11.1	5.8	10	4.2	1.7
08	Female	8	24.6	12.9	11.1	5.8	10	4.2	1.7
09	Male	10	21.6	10	8.4	4.7	7.5	3.25	1.3
10	Female	10	21.5	10	8.4	4.7	7.5	3.25	1.3
11	Male	12/14	19.3	7.7	6.35	3.8	6	2.5	1
12	Female	12/14	19.2	7.7	6.35	3.8	6	2.5	1

NOTES:

1. Measurement point for plating thickness.
2. All dimensions are in millimetres.
3. Washer is optional.

FIGURE 2(c) - STRAIGHT AND 90° PCB TYPES

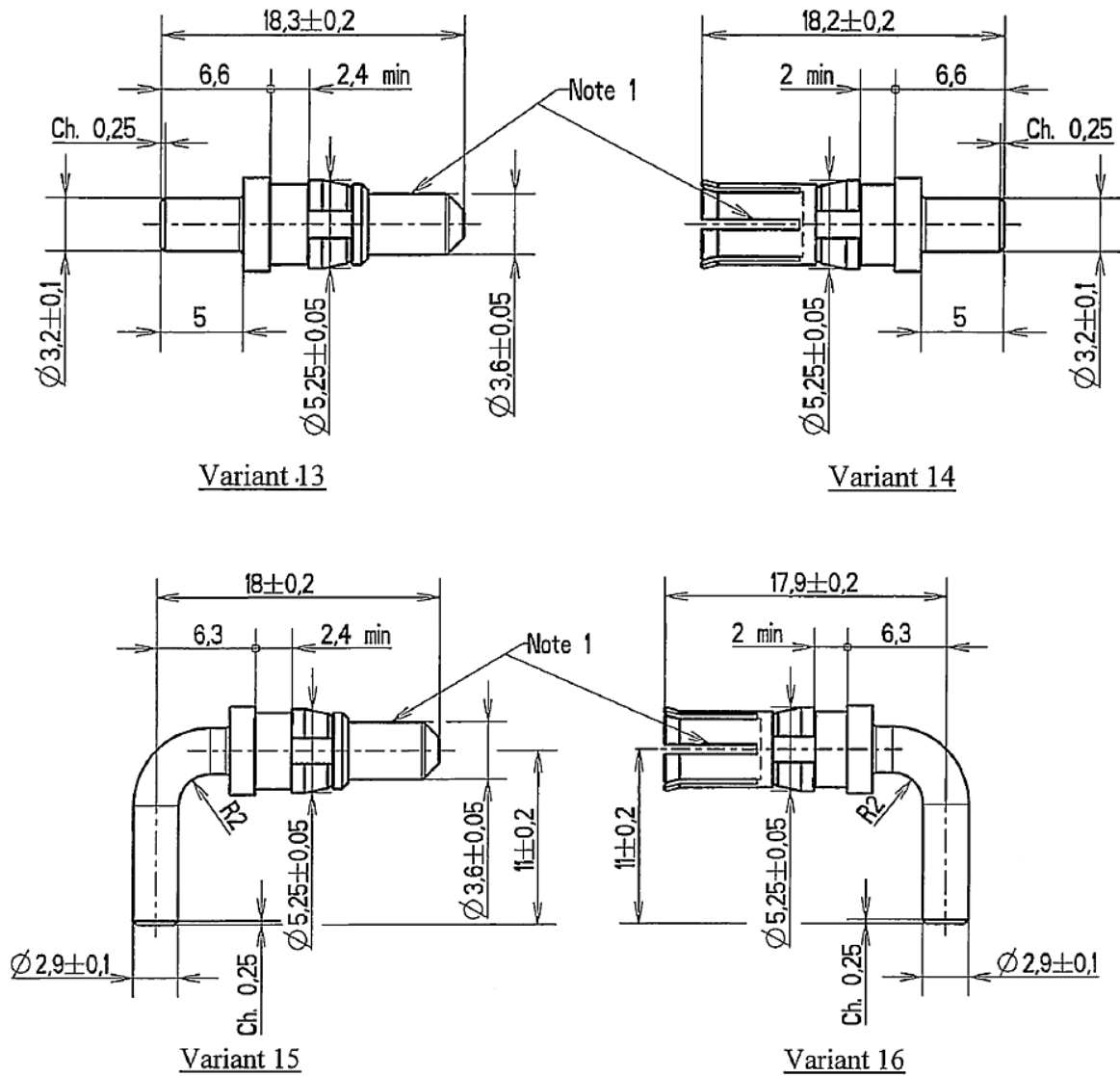

NOTES:

1. Measurement point for plating thickness.
2. All dimensions are in millimetres.
3. Variants 15 and 16 are applicable to shell sizes E, A, B and C only.

FIGURE 2(d) - SAVERS TYPE

Variant 17

Note 1

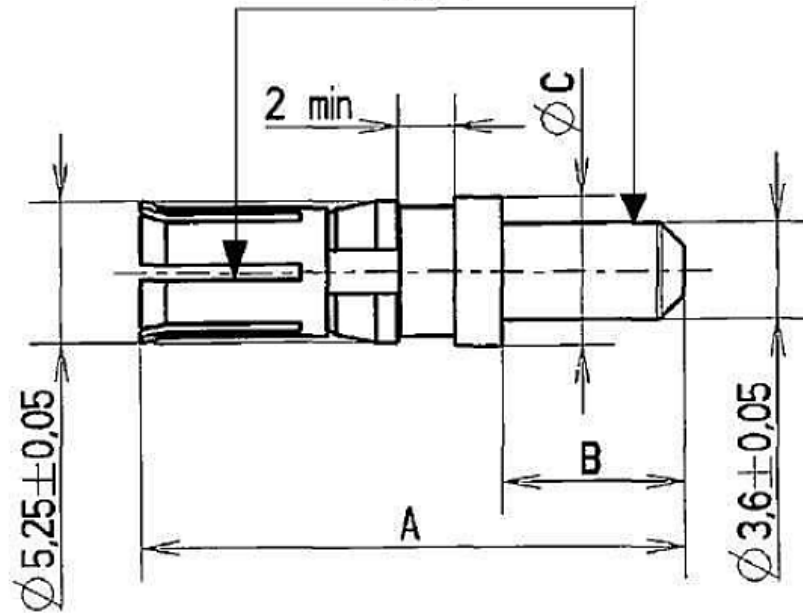

Variant (Note 2)	Type	A Max.	B Min.	ØC Max.
17	Saver	20.2	6.5	5.66

NOTES:

1. Measurement point for plating thickness.
2. All dimensions are in millimetres.

FIGURE 2(e) - PROTRUSION AND RECESS

MAXIMUM PROTRUSION OF CONTACTS RELATIVE TO REAR OF SHELL FLANGE

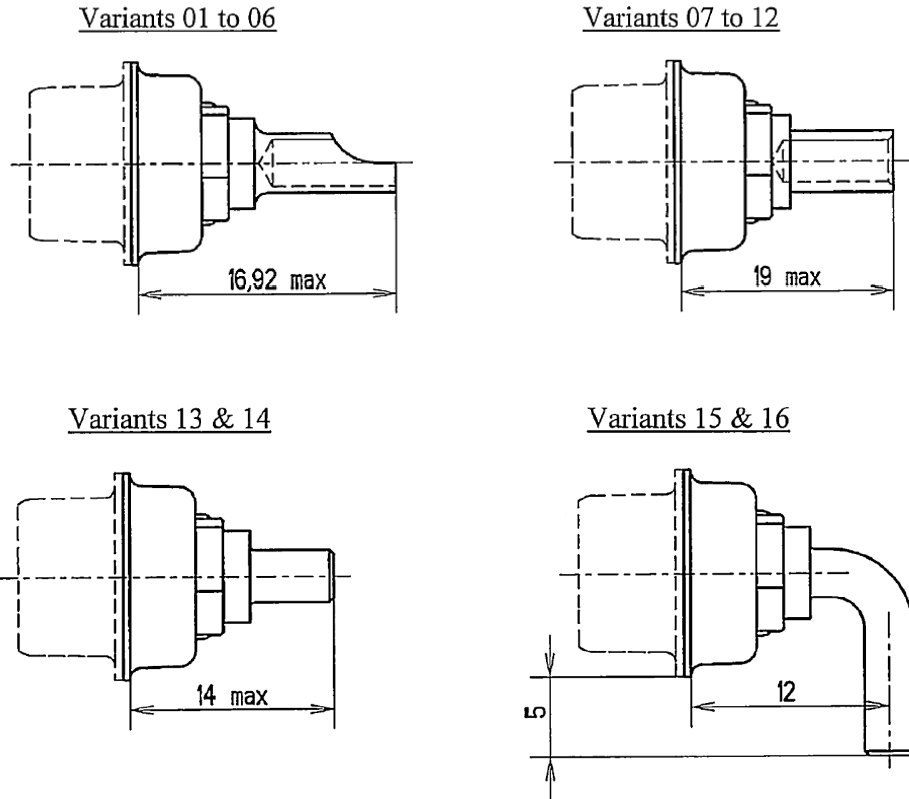

MAXIMUM RECESS OF CONTACTS RELATIVE TO FRONT OF SHELL

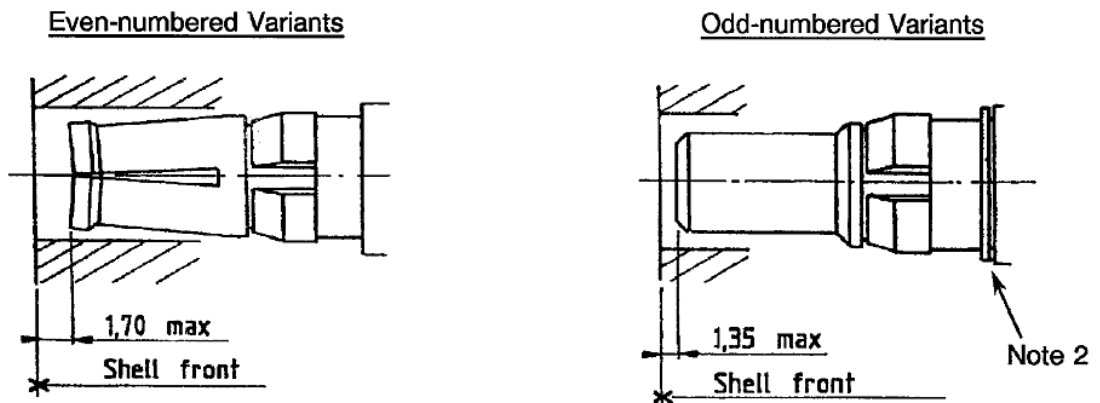

NOTES:

1. All dimensions are in millimetres.
2. The washer is optional (no change of the insert: the assembling dimension is compensated on the contact).

2 **APPLICABLE DOCUMENTS**

The following documents form part of this specification and shall be read in conjunction with it:

- (a) ESCC Generic Specification No. 3401 for Connectors, Electrical, Non-Filtered, Circular and Rectangular.
- (b) ESCC Detail Specification No. 3401/001, Connectors, Electrical, Rectangular, Non-removable Solder Bucket, PCB and Wire-wrap Contacts and Removable Coaxial and Power Contacts, Based on Type D*M.
- (c) ESCC Detail Specification No. 3401/080, Connector Savers, Electrical, Rectangular, Miniature, Non-Removable Signal Contacts, And Removable Coaxial and Power Contacts.

3 **TERMS, DEFINITIONS, ABBREVIATIONS, SYMBOLS AND UNITS**

For the purpose of this specification, the terms, definitions, abbreviations, symbols and units specified in ESCC Basic Specification No. 21300 shall apply.

4 **REQUIREMENTS**

4.1 **GENERAL**

The complete requirements for procurement of the contacts specified herein are stated in this specification and ESCC Generic Specification No. 3401. Deviations from the Generic Specification, applicable to this specification only, are detailed in Para. 4.2.

Deviations from the applicable Generic Specification and this Detail Specification, formally agreed with specific Manufacturers on the basis that the alternative requirements are equivalent to the ESCC requirements and do not affect the components' reliability, are listed in the appendices attached to this specification.

4.2 **DEVIATIONS FROM GENERIC SPECIFICATION**

4.2.1 **Deviations from Special In-Process Controls**

None.

4.2.2 **Deviations from Final Production Tests (Chart II)**

None.

4.2.3 **Deviations from Burn-in and Electrical Measurements (Chart III)**

Chart III is not applicable.

4.2.4 **Deviations from Qualification Tests (Chart IV)**

- (a) Para. 9.29, Oversize Pin Exclusion: Not applicable.
- (b) Para. 9.30, Probe Damage: Not applicable.
- (c) Para. 9.31, Solderability: Not applicable to Variants 07 to 12 and 17.
- (d) Para. 9.15, Joint Strength: The test shall be performed as specified in Para. 4.3.13.

4.2.5 **Deviations from Lot Acceptance Tests (Chart V)**

The deviations as listed in Para. 4.2.4 shall apply.

4.3 MECHANICAL REQUIREMENTS

4.3.1 Dimension Check

The dimensions of the contacts specified herein shall be verified in accordance with the requirements set out in Para. 9.6 of ESCC Generic Specification No. 3401 and they shall conform to those shown in Figure 2 of this specification. Overall dimensions are specified with compatible inserts in ESCC Detail Specification No. 3401/001 and 3401/080.

4.3.2 Weight

The maximum weight of the contacts specified herein shall be as given in Table 1(a).

4.3.3 Contact Capability (Variants 02, 04, 06, 08, 10, 12, 14, 16, 17)

For the purpose of this test, the pick-up and drop weights shall be as follows.

	Pick-Up Weight	Drop Weight
Weight (g)	85	567
Pin diameter (mm)	3.581 (+0.0025, -0)	3.632 (+0, -0.0025)
Insertion Depth (mm)	3.17	3.17

4.3.4 Contact Retention (in Insert)

Contact retention within the insert shall be 40.86N. There shall be no displacement of the contact in excess of 0.3mm.

4.3.5 Mating and Unmating Forces

As specified in ESCC Detail Specification No. 3401/001.

4.3.6 Insert Retention (in Shell)

As specified in ESCC Detail Specification No. 3401/001.

4.3.7 Jackscrew Retention

Not applicable.

4.3.8 Contact Insertion and Withdrawal Forces

The contact insertion and withdrawal forces shall be 65N maximum.

4.3.9 Engagement and Separation Forces (Variants 02, 04, 06, 08, 10, 12, 14, 16, 17)

The engagement and separation forces of the female contacts shall be as specified hereunder.

	Maximum Diameter Test Pin 3.632 (+0, -0.0025) mm	Minimum Diameter Test Pin 3.581 (+0.0025, -0) mm
Engagement Force (N)	6.87 max	0.83 min
Separation Force (N)	5.56 max	0.83 min

4.3.10 Oversize Pin Exclusion

Not applicable.

4.3.11 Probe Damage

Not applicable.

4.3.12 Solderability

Not applicable to Variants 07 to 12 and 17. For all other Variants soldering iron bit size 7.5mm shall be used.

4.3.13 Joint Strength (Variants 07 to 12)

The contacts shall be crimped to stranded wire of the appropriate size as shown below. The contact and the wire shall be separated from each other, using a tensile strength machine. The values of the force at separation of the contact and wire and the method of failure shall be recorded and shall be in accordance with the following values:

Variant	Wire Size (AWG)	Minimum Value of Tensile Strength (N)
07, 08	8	> 500
09, 10	10	> 500
11, 12	12 - 14	> 500

i.e. "pull-out", "break in crimp", "break in wire".

4.4 MATERIALS AND FINISHES

The materials and finishes shall be as specified herein. Where a definite material is not specified, a material which will enable the contacts specified herein to meet the performance requirements of this specification shall be used. Acceptance or approval of any constituent material does not guarantee acceptance of the finished product.

4.4.1 Contact Body

The contacts shall be made of copper base alloy selected from raw materials with a minimum of impurities. Gold plating thickness shall be 1.27µm minimum over 1µm minimum of copper.

4.4.2 Magnetism Level

As specified in ESCC Detail Specification No. 3401/001.

4.5 MARKING

4.5.1 General

The marking of all components delivered to this specification shall be in accordance with the requirements of ESCC Basic Specification No. 21700 and the following paragraphs. These components being too small to accommodate the marking specified hereafter, the full marking information shall accompany the component in its primary package.

Such marking shall comprise:

- (a) The ESCC Component Number.
- (b) Traceability Information.
- (c) Quantity of Components.

4.5.2 The ESCC Component Number

The ESCC Component Number shall be constituted and marked as follows:

Example: 340104001B

- Detail Specification Number: 3401040
- Type Variant (See Table 1(a)): 01
- Testing Level: B

4.5.3 Traceability Information

Traceability information shall be marked in accordance with ESCC Basic Specification No. 21700.

4.6 ELECTRICAL MEASUREMENTS

4.6.1 Electrical Measurements at Room Temperature

The parameters to be measured in respect of electrical characteristics are scheduled in Table 2. Unless otherwise specified these measurements shall be performed at $T_{amb} = +22 \pm 3 \text{ }^\circ\text{C}$.

4.6.2 Electrical Measurements at High and Low Temperatures (Table 3)

Not applicable.

4.6.3 Circuits for Electrical Measurements

Not applicable

4.7 SCREENING TESTS (TABLES 4 AND 5)

Not applicable.

TABLE 2 - ELECTRICAL MEASUREMENTS AT ROOM TEMPERATURE

No.	Characteristics	Symbol	ESCC 3401 Test Method	Test Conditions	Limits		Unit
					Min	Max	
1	Low Level Contact Resistance	R_{CL}	Para. 9.1.1.3	Para. 9.1.1.3	-	2.5	m Ω
2	Rated Current Contact Resistance	R_{CR}	Para. 9.1.1.3	Para. 9.1.1.3	-	2	m Ω

TABLES 3, 4 AND 5

Not applicable.

4.8 ENVIRONMENTAL AND ENDURANCE TESTS

4.8.1 Measurements and Inspections on Completion of Environmental Tests

The parameters to be measured and inspections to be performed on completion of environmental tests are scheduled in Table 6. Unless otherwise specified, the measurements shall be performed at $T_{amb} = +22 \pm 3 \text{ }^\circ\text{C}$.

4.8.2 Measurements and Inspections at Intermediate Points During Endurance Tests
Not applicable.

4.8.3 Measurements and Inspections on Completion of Endurance Tests
The parameters to be measured and inspections to be performed on completion of endurance tests shall be those specified in Table 6. Unless otherwise specified, these measurements shall be performed at $T_{amb} = +22 \pm 3 \text{ }^\circ\text{C}$.

4.8.4 Conditions for Operating Life Test (Part of Endurance Testing)
Not applicable.

4.8.5 Electrical Circuit for Operating Life Test
Not applicable.

4.8.6 Conditions for High Temperature Storage Test (Part of Endurance Testing)
The requirements for the high temperature storage test are specified in Section 9 of ESCC Generic Specification No. 3401. The conditions for high temperature storage testing shall be the maximum storage temperature specified in Table 1(b) of this specification.

TABLE 6 - MEASUREMENTS AND INSPECTIONS ON COMPLETION OF ENVIRONMENTAL AND ENDURANCE TESTING

No.	ESCC Generic Spec. No. 3401		Measurements and Inspections		Symbol	Limits		Unit
	Environmental and Endurance Tests (1)	Test Methods and Conditions	Identification	Conditions		Min	Max	
01	Wiring	Para. 9.10	Visual Examination Low Level Contact Resistance	- Table 2 Item 1	- R_{CL}	- -	- 2.5	- $m\Omega$
02	Vibration	Para. 9.11	ESCC 3401/001	-	-	-	-	-
03	Shock or Bump	Para. 9.12	ESCC 3401/001	-	-	-	-	-
04	Climatic Sequence	Para. 9.13	ESCC 3401/001	-	-	-	-	-
05	Seal Test	Para. 9.9	Not applicable	-	-	-	-	-
06	Plating Thickness	Para. 9.14 & Para. 4.4.1 of this Spec.	Thickness	Para. 4.4.1 of this spec.	-	Para. 4.4.1 of this spec.		-
07	Joint Strength	Para. 9.15 & Para. 4.3.13 of this Spec.	Visual Examination Low Level Contact Resistance	- Table 2 Item 1	- R_{CL}	- -	- 2.5	- $m\Omega$
08	Rapid Change of Temperature	Para. 9.16	ESCC 3401/001	-	-	-	-	-

No.	ESCC Generic Spec. No. 3401		Measurements and Inspections		Symbol	Limits		Unit
	Environmental and Endurance Tests (1)	Test Methods and Conditions	Identification	Conditions		Min	Max	
09	Contact Retention (in Insert)	Para. 9.17 & Para. 4.3.4 of this spec. Force: 40.86N	Contact Displacement	Para. 4.3.4 of this spec.	-	Para. 4.3.4 of this spec.		-
10	Endurance	Para. 9.18	Initial Measurement	Table 2 Item 1	R _{CL}	-	2.5	mΩ
			Low Level Contact Resistance					
			Final Inspection	Table 2 Item 1	ΔR _{CL}	-	0.5	mΩ
			Visual Examination					
Final Measurement								
			Low Level Contact Resistance Drift					
11	Permanence of Marking	Para. 9.19	As applicable	-	-	-	-	-
12	Mating/Unmating Forces	Para. 9.20	ESCC 3401/001	-	-	-	-	-
13	High Temperature Storage	Para. 9.21	Initial	Table 2 Item 1	R _{CL}	-	2.5	mΩ
			Low Level Contact Resistance					
			Final Inspection	Table 2 Item 1	ΔR _{CL}	-	0.5	mΩ
			Visual Examination					
			Final Measurement	Table 2 Item 2	R _{CR}	-	2	mΩ
Low Level Contact Resistance Drift								
Rated Current Contact Resistance	Para. 4.3.4 of this spec.	-	Para. 4.3.4 of this spec.		-			
14	Corrosion	Para. 9.22	ESCC 3401/001	-	-	-	-	-
15	Insert Retention (in Shell)	Para. 9.23	ESCC 3401/001	-	-	-	-	-
16	Jackscrew Retention	Para. 9.24	Not applicable	-	-	-	-	-
17	High Temperature Measurements	Para. 9.25	ESCC 3401/001	-	-	-	-	-
18	Overload Test	Para. 9.26	Rated Current Contact Resistance	Table 2 item 2	R _{CR}	-	2	mΩ

No.	ESCC Generic Spec. No. 3401		Measurements and Inspections		Symbol	Limits		Unit
	Environmental and Endurance Tests (1)	Test Methods and Conditions	Identification	Conditions		Min	Max	
19	Maintenance Aging	Para. 9.27	Final Measurements Contact Retention (in Insert) Contact Insertion & Withdrawal Forces	Para. 4.3.4 of this spec. Para. 4.3.8 of this spec.	- -	Para. 4.3.4 of this spec. Para. 4.3.8 of this spec.	- -	- -
20	Engagement and Separation Forces	Para. 9.28 & para. 4.3.9 of this spec.	Force	-	-	Para. 4.3.9 of this spec.	-	-
21	Oversize Pin Exclusion	Para. 9.29 & para. 4.3.10 of this spec.	Not applicable	-	-	-	-	-
22	Probe Damage	Para. 9.30 & para. 4.3.11 of this spec.	Not applicable	-	-	-	-	-
23	Solderability	Para. 9.31 & para. 4.3.12 of this spec.	Visual Examination	-	-	-	-	-

NOTES:

1. The tests in this table refer to either Chart IV or V and shall be used as applicable.