



**RELAY, ELECTROMAGNETIC, LATCHING,
28VDC, 15A, 4PDT**

ESCC Detail Specification No. 3602/004

| | |
|---------|-----------|
| Issue 5 | June 2021 |
|---------|-----------|



LEGAL DISCLAIMER AND COPYRIGHT

European Space Agency, Copyright © 2021. All rights reserved.

The European Space Agency disclaims any liability or responsibility, to any person or entity, with respect to any loss or damage caused, or alleged to be caused, directly or indirectly by the use and application of this ESCC publication.

This publication, without the prior permission of the European Space Agency and provided that it is not used for a commercial purpose, may be:

- copied in whole, in any medium, without alteration or modification.
- copied in part, in any medium, provided that the ESCC document identification, comprising the ESCC symbol, document number and document issue, is removed.

DOCUMENTATION CHANGE NOTICE

(Refer to <https://escies.org> for ESCC DCR content)

| DCR No. | CHANGE DESCRIPTION |
|---------|---|
| 1424 | Specification updated to incorporate changes per DCR. |

TABLE OF CONTENTS

| | | |
|---------|--|----|
| 1 | GENERAL | 5 |
| 1.1 | SCOPE | 5 |
| 1.2 | APPLICABLE DOCUMENTS | 5 |
| 1.3 | TERMS, DEFINITIONS, ABBREVIATIONS, SYMBOLS AND UNITS | 5 |
| 1.4 | THE ESCC COMPONENT NUMBER AND COMPONENT TYPE VARIANTS | 5 |
| 1.4.1 | The ESCC Component Number | 5 |
| 1.4.1.1 | Characteristics and/or Ratings Codes | 5 |
| 1.4.2 | Component Type Variants and Range of Components | 6 |
| 1.5 | MAXIMUM RATINGS | 7 |
| 1.6 | PHYSICAL DIMENSIONS AND TERMINAL IDENTIFICATION | 8 |
| 1.6.1 | Raised Vertical Flange Mount and Solder Pin Terminals (Variants 04, 14) | 8 |
| 1.6.2 | Raised Vertical Flange Mount and Solder Hook Terminals (Variants 06, 16) | 9 |
| 1.6.3 | Horizontal Flange Mount and Solder Hook Terminals (Variants 09, 19) | 10 |
| 1.7 | FUNCTIONAL DIAGRAM | 11 |
| 1.8 | MATERIALS AND FINISHES | 11 |
| 1.8.1 | Case | 11 |
| 1.8.2 | Terminals | 11 |
| 2 | REQUIREMENTS | 11 |
| 2.1 | GENERAL | 11 |
| 2.1.1 | Deviations from the Generic Specification | 11 |
| 2.1.1.1 | Deviations from Qualification and Periodic Tests – Chart F4 | 11 |
| 2.2 | MARKING | 12 |
| 2.3 | TERMINAL STRENGTH | 12 |
| 2.4 | ELECTRICAL MEASUREMENTS AT ROOM, HIGH AND LOW TEMPERATURES | 12 |
| 2.4.1 | Room Temperature Electrical Measurements | 12 |
| 2.4.2 | High and Low Temperatures Electrical Measurements | 13 |
| 2.4.3 | Notes to Electrical Measurements Tables | 13 |
| 2.5 | PARAMETER DRIFT VALUES | 14 |
| 2.6 | INTERMEDIATE AND END-POINT ELECTRICAL MEASUREMENTS | 14 |
| 2.7 | RUN-IN CONDITIONS | 20 |
| | APPENDIX A | 21 |
| | APPENDIX B | 22 |

1 GENERAL

1.1 SCOPE

This specification details the ratings, physical and electrical characteristics, and test and inspection data for the component type variants and/or the range of components specified below. It supplements the requirements of, and shall be read in conjunction with, the ESCC Generic Specification listed under Applicable Documents.

1.2 APPLICABLE DOCUMENTS

The following documents form part of this specification and shall be read in conjunction with it:

- (a) ESCC Generic Specification No. [3602](#).

1.3 TERMS, DEFINITIONS, ABBREVIATIONS, SYMBOLS AND UNITS

For the purpose of this specification, the terms, definitions, abbreviations, symbols and units specified in ESCC Basic Specification No. [21300](#) shall apply.

1.4 THE ESCC COMPONENT NUMBER AND COMPONENT TYPE VARIANTS

1.4.1 The ESCC Component Number

The ESCC Component Number shall be constituted as follows:

Example: 36020040428V

- Detail Specification Reference: 3602004
- Component Type Variant Number: 04 (as required)
- Characteristic code: Rated Coil Voltage (28Vdc): 28V (as required)

1.4.1.1 *Characteristics and/or Ratings Codes*

Characteristics and/or ratings to be codified as part of the ESCC Component Number shall be as follows:

- (a) Rated Coil Voltage expressed by means of the following codes:

| Rated Coil Voltage (Vdc) | Code |
|--------------------------|------|
| 28 | 28V |
| 12 | 12V |

1.4.2 Component Type Variants and Range of Components

The component type variants and range of components applicable to this specification are as follows:

| Variant Number | Case and Terminal Description (Note 1) | Rated Coil Voltage (Vdc) | Coil Resistance (Ω) | Weight max (g) |
|----------------|--|--------------------------|---------------------|----------------|
| 04 | Raised Vertical Flange Mount Solder Pin Terminals | 28 | 300 | 80 |
| | | 12 | 60 | |
| 06 | Raised Vertical Flange Mount Solder Hook Terminals | 28 | 300 | 80 |
| | | 12 | 60 | |
| 09 | Horizontal Flange Mount Solder Hook Terminals | 28 | 300 | 80 |
| | | 12 | 60 | |
| 14 | Raised Vertical Flange Mount Solder Pin Terminals | 28 | 450 | 80 |
| | | 12 | 111.5 | |
| 16 | Raised Vertical Flange Mount Solder Hook Terminals | 28 | 450 | 80 |
| | | 12 | 111.5 | |
| 19 | Horizontal Flange Mount Solder Hook Terminals | 28 | 450 | 80 |
| | | 12 | 111.5 | |

NOTES:

1. See Para. 1.6.

1.5 MAXIMUM RATINGS

The maximum ratings shall not be exceeded at any time during use or storage.

Maximum ratings shall only be exceeded during testing to the extent specified in this specification and when stipulated in Test Methods and Procedures of the ESCC Generic Specification.

| Characteristics | Symbols | Maximum Ratings | Units | Remarks |
|--------------------------------------|----------------|--------------------------|-------|--|
| Coil Voltage Range | V_{CR} | 26.5 to 32 11 to 14.5 | Vdc | Rated Coil Voltage: 28Vdc Rated Coil Voltage: 12Vdc |
| Rated Resistive Load Contact Current | I_{CR} | 15 | A | 28Vdc resistive Note 1 |
| Rated Inductive Load Contact Current | I_{CL} | 8 | A | 28Vdc inductive Note 1 |
| Overload Current | $I_{OVERLOAD}$ | 40 | A | 28Vdc resistive |
| Operating Temperature Range | T_{op} | -65 to +125 | °C | T_{amb} |
| Storage Temperature Range | T_{stg} | -65 to +125 | °C | T_{amb} |
| Soldering Temperature | T_{sol} | +260 | °C | Note 2 |

NOTES:

1. Relays should not be used in change-over mode where the potential difference between stationary contacts is greater than 10V and the switched current is greater than 100mA.
2. Duration 10 seconds maximum at a distance not less than 3mm from the device body. The same terminal shall not be resoldered until 3 minutes have elapsed.

1.6 PHYSICAL DIMENSIONS AND TERMINAL IDENTIFICATION

1.6.1 Raised Vertical Flange Mount and Solder Pin Terminals (Variants 04, 14)

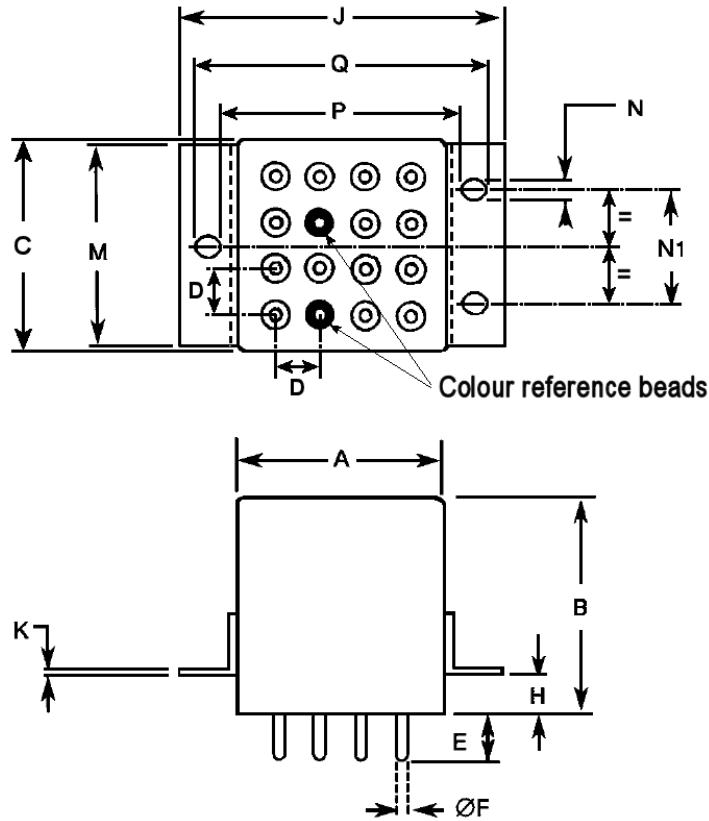

| Symbols | Dimensions (mm) | |
|---------|-----------------|-------|
| | Min | Max |
| A | - | 26 |
| B | - | 26 |
| C | - | 26 |
| D | 4.88 | 5.28 |
| E | 6.7 | 7.1 |
| ØF | 1.55 | 1.62 |
| H | 3.8 | 4.2 |
| J | - | 43.6 |
| K | 0.9 | 1.1 |
| M | 23.6 | 24 |
| N | 3.7 | 3.9 |
| N1 | 15.65 | 16.15 |
| P | 31.15 | 32.15 |
| Q | 40 | 41 |

NOTES:

- Terminal identification is specified by reference to the colour reference beads. See Para. 1.7.

1.6.2 Raised Vertical Flange Mount and Solder Hook Terminals (Variants 06, 16)

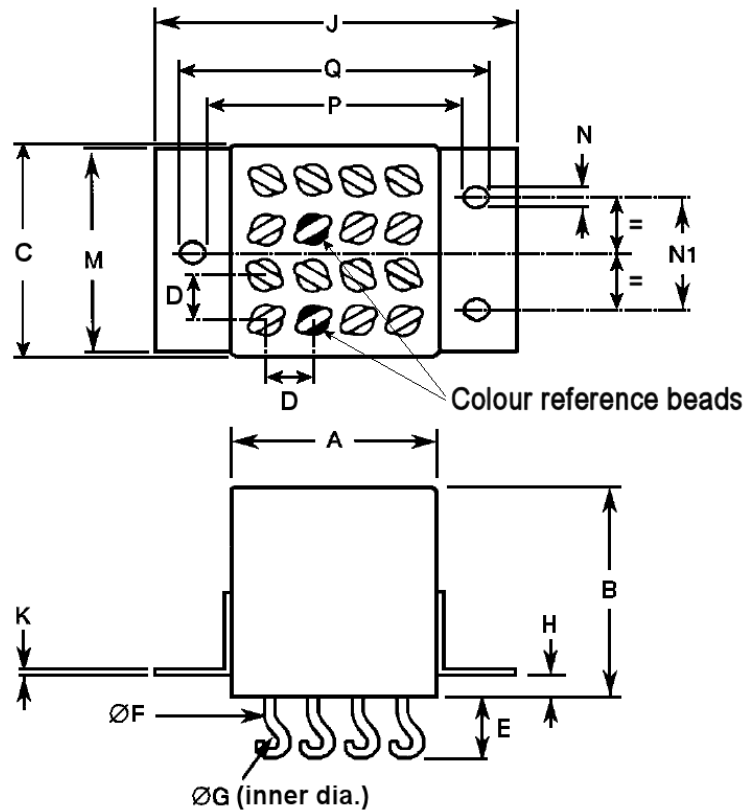

| Symbols | Dimensions (mm) | |
|---------|-----------------|-------|
| | Min | Max |
| A | - | 26 |
| B | - | 26 |
| C | - | 26 |
| D | 4.88 | 5.28 |
| E | - | 8 |
| ØF | 1.52 | 1.63 |
| ØG | 1.75 | 2.25 |
| H | 3.8 | 4.2 |
| J | - | 43.6 |
| K | 0.9 | 1.1 |
| M | 23.6 | 24 |
| N | 3.7 | 3.9 |
| N1 | 15.65 | 16.15 |
| P | 31.15 | 32.15 |
| Q | 40 | 41 |

NOTES:

- Terminal identification is specified by reference to the colour reference beads. See Para. 1.7.

1.6.3 Horizontal Flange Mount and Solder Hook Terminals (Variants 09, 19)

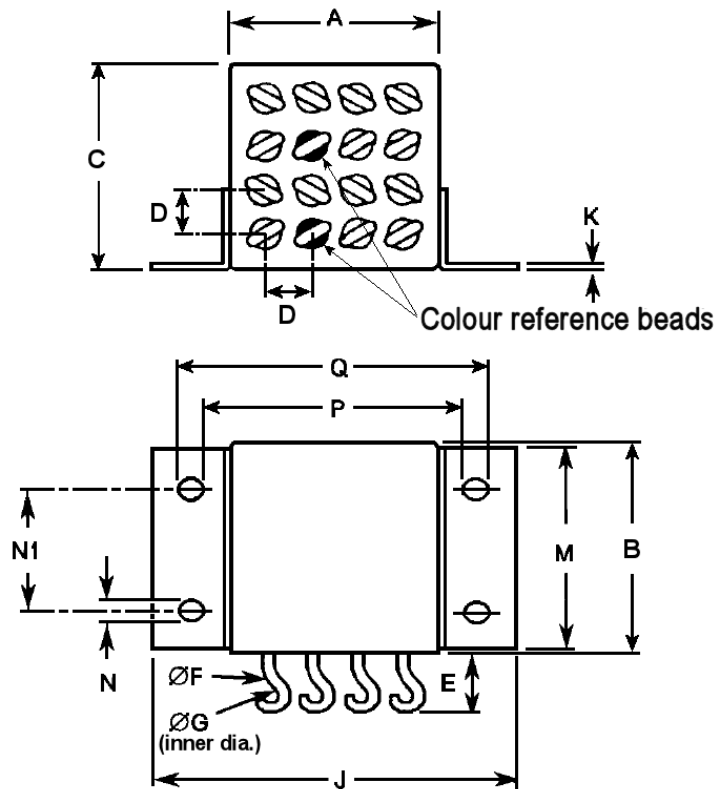

| Symbols | Dimensions (mm) | |
|---------|-----------------|-------|
| | Min | Max |
| A | - | 26 |
| B | - | 26 |
| C | - | 26 |
| D | 4.88 | 5.28 |
| E | - | 8 |
| ØF | 1.52 | 1.63 |
| ØG | 1.75 | 2.25 |
| J | - | 43.6 |
| K | 0.9 | 1.1 |
| M | 23.6 | 24 |
| N | 3.7 | 3.9 |
| N1 | 15.65 | 16.15 |
| P | 31.15 | 32.15 |
| Q | 40 | 41 |

NOTES:

- Terminal identification is specified by reference to the colour reference beads. See Para. 1.7.

1.7 FUNCTIONAL DIAGRAM

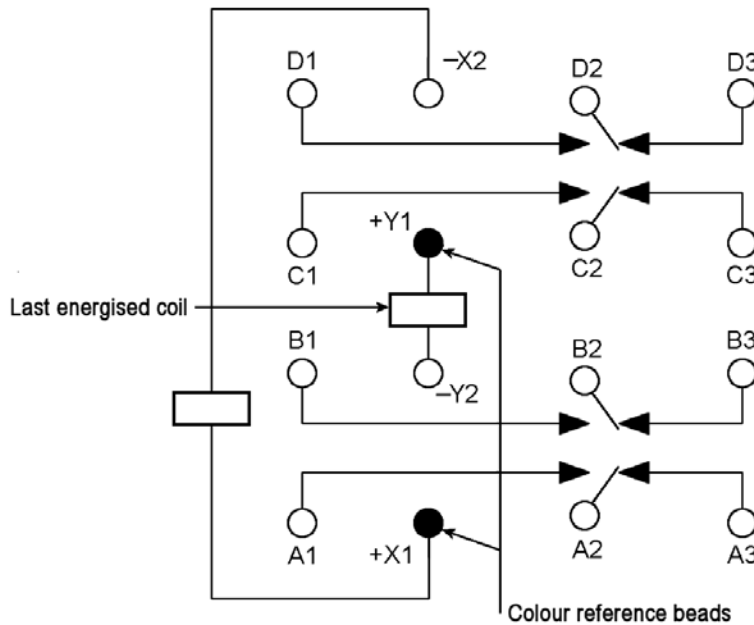

NOTES:

1. As viewed from the terminal side.
2. Individual terminal designations are for reference purposes only.

1.8 MATERIALS AND FINISHES

1.8.1 Case

Copper nickel, tin-lead alloy plated, hermetically sealed.

1.8.2 Terminals

The lead material and finish shall be type H3, H4 or H19 in accordance with the requirements of ESCC Basic Specification No. [23500](#).

2 REQUIREMENTS

2.1 GENERAL

The complete requirements for procurement of the components specified herein are as stated in this specification and the ESCC Generic Specification. Permitted deviations from the Generic Specification, applicable to this specification only, are listed below.

Permitted deviations from the Generic Specification and this Detail Specification, formally agreed with specific Manufacturers on the basis that the alternative requirements are equivalent to the ESCC requirement and do not affect the component's reliability, are listed in the appendices attached to this specification.

2.1.1 Deviations from the Generic Specification

2.1.1.1 *Deviations from Qualification and Periodic Tests – Chart F4*

- (a) High Level Mechanical Shock. The mechanical shock test condition peak value shall be 500g.

2.2 MARKING

The marking shall be in accordance with the requirements of ESCC Basic Specification No. 21700 and as follows.

The information to be marked on the component shall be:

- (a) The ESCC qualified components symbol (for ESCC qualified components only).
- (b) The ESCC Component Number (see Para. 1.4.1).
- (c) Traceability information.

2.3 TERMINAL STRENGTH

The terminals of all Variants are defined as rigid.

The test conditions for Terminal Strength, tested as specified in the ESCC Generic Specification, shall be as follows:

- (a) Pull Test :
 - Applied Force: 50N

2.4 ELECTRICAL MEASUREMENTS AT ROOM, HIGH AND LOW TEMPERATURES

Electrical measurements shall be performed at room, high and low temperatures. Consolidated notes are given in Para. 2.4.3.

2.4.1 Room Temperature Electrical Measurements

The measurements shall be performed at $T_{amb} = +22 \pm 3^{\circ}C$.

| Characteristics | Symbols | Test Method and Conditions | Rated Coil Voltage (Vdc) | Limits | | Units |
|-------------------------------|-----------|--|--------------------------|---------------|------------------------|-------|
| | | | | Min | Max | |
| Latch Voltage | U_L | ESCC No. 3602 Note 1 | 28 12 | 8 3.6 | 14 6.6 | V |
| Reset Voltage | U_R | ESCC No. 3602 Note 1 | 28 12 | 8 3.6 | 14 6.6 | V |
| Latch Time | t_L | ESCC No. 3602 | All | - | 15 | ms |
| Reset Time | t_R | ESCC No. 3602 | All | - | 15 | ms |
| Bounce Time | t_B | ESCC No. 3602 | All | - | 1 | ms |
| Insulation Resistance | R_I | ESCC No. 3602 $V_{TEST} = 500V_{dc}$ | All | 100 | - | MΩ |
| Voltage Proof (Test Voltage) | VP | ESCC No. 3602 Maximum Leakage Current $I_{LVP} = 1mA$ | All | 1250 | - | Vrms |
| | | | | 1000 (Note 2) | - | |
| | | | | 350 (Note 3) | - | |
| Voltage Proof Leakage Current | I_{LVP} | ESCC No. 3602 Note 4 | All | - | 1 | mA |
| Contact Voltage Drop | V_D | ESCC No. 3602 $100mA \leq I_{TEST} \leq 15A$ | All | - | $0.01 \times I_{TEST}$ | V |

| Characteristics | Symbols | Test Method and Conditions | Rated Coil Voltage (Vdc) | Limits | | Units |
|-----------------|----------------|---|--------------------------|--------|-----|-------|
| | | | | Min | Max | |
| Coil Resistance | R _B | ESCC No. 3602 Both coils | | | | Ω |
| | | Variants 04, 06, 09 | 28 | 270 | 330 | |
| | | Variants 04, 06, 09 | 12 | 54 | 66 | |
| | | Variants 14, 16, 19 | 28 | 405 | 495 | |
| | | Variants 14, 16, 19 | 12 | 100 | 123 | |

2.4.2 High and Low Temperatures Electrical Measurements

| Characteristics | Symbols | Test Method and Conditions | Rated Coil Voltage (Vdc) | Limits | | Units |
|-----------------------|----------------|--|--------------------------|--------|--------------------------|-------|
| | | | | Min | Max | |
| Latch Voltage | U _L | ESCC No. 3602 T _{amb} = +125 (+0 -5)°C and -65 (+5 -0)°C Note 1 | 28 | - | 18 | V |
| | | | 12 | - | 9 | |
| Reset Voltage | U _R | ESCC No. 3602 T _{amb} = +125 (+0 -5)°C and -65 (+5 -0)°C Note 1 | 28 | - | 18 | V |
| | | | 12 | - | 9 | |
| Latch Time | t _L | ESCC No. 3602 T _{amb} = +125 (+0 -5)°C and -65 (+5 -0)°C | All | - | 15 | ms |
| Reset Time | t _R | ESCC No. 3602 T _{amb} = +125 (+0 -5)°C and -65 (+5 -0)°C | All | - | 15 | ms |
| Bounce Time | t _B | ESCC No. 3602 T _{amb} = +125 (+0 -5)°C and -65 (+5 -0)°C | All | - | 1 | ms |
| Insulation Resistance | R _I | ESCC No. 3602 T _{amb} = +125 (+0 -5)°C V _{TEST} = 500Vdc | All | 50 | - | MΩ |
| Contact Voltage Drop | V _D | ESCC No. 3602 T _{amb} = +125 (+0 -5)°C and -65 (+5 -0)°C 100mA ≤ I _{TEST} ≤ 15A | All | - | 0.01 x I _{TEST} | V |

2.4.3 Notes to Electrical Measurements Tables

1. The coil voltage rise time shall be less than 0.1t_L or 0.1t_R. The coil voltage shall be maintained for a minimum duration of 10t_L or 10t_R.
2. Between coil and case.
3. Between latch and reset coils.
4. Measured during Voltage Proof test.

2.5 PARAMETER DRIFT VALUES

Parameter Drift Values shall be measured as specified in the ESCC Generic Specification.

Unless otherwise specified, the measurements shall be performed at $T_{amb} = +22 \pm 3^{\circ}C$.

The test methods and test conditions shall be as per the corresponding test defined in Para. 2.4.1 Room Temperature Electrical Measurements.

The corresponding absolute limit values for each characteristic shall not be exceeded.

| Characteristics | Symbols | Limits | | | Units |
|-----------------|---------|-------------------------|----------|--------|-------|
| | | Drift Value Δ | Absolute | | |
| | | | Min | Max | |
| Latch Voltage | U_L | Note 1 | Note 2 | Note 2 | V |
| Reset Voltage | U_R | Note 1 | Note 2 | Note 2 | V |

NOTES:

1. Drift Value (Δ) limits are not specified. Drift Values shall be recorded for information purposes only.
2. The limit specified in Para. 2.4.1 shall apply.

2.6 INTERMEDIATE AND END-POINT ELECTRICAL MEASUREMENTS

Unless otherwise specified, the measurements shall be performed at $T_{amb} = +22 \pm 3^{\circ}C$.

Unless otherwise specified the test methods and test conditions shall be as per the corresponding test defined in Para. 2.4.1 Room Temperature Electrical Measurements.

| Test Reference per ESCC No. 3602 | Characteristics | Symbols | Limits | | Units |
|---|---------------------------|---------|--------|-----|-------|
| | | | Min | Max | |
| Thermal Shock | <u>During 5th Cycle</u> | | | | |
| | Latch Voltage | U_L | Note 2 | | V |
| | Reset Voltage | U_R | Note 2 | | V |
| | Latch Time | t_L | Note 2 | | ms |
| | Reset Time | t_R | Note 2 | | ms |
| | <u>Final Measurements</u> | | | | |
| | Voltage Proof | VP | Note 3 | | Vrms |
| Voltage Proof Leakage Current | I_{LVP} | Note 3 | | mA | |

| Test Reference per ESCC No. 3602 | Characteristics | Symbols | Limits | | Units |
|-------------------------------------|-------------------------------|------------------|--------|------------|-------|
| | | | Min | Max | |
| Low Level Sine Vibration | <u>Final Measurements</u> | | | | |
| | Latch Voltage | U_L | Note 3 | V | |
| | Latch Voltage Drift | $\Delta U_L/U_L$ | Note 1 | % | |
| | Reset Voltage | U_R | Note 3 | V | |
| | Reset Voltage Drift | $\Delta U_R/U_R$ | Note 1 | % | |
| High Level Sine Vibration | <u>Final Measurements</u> | | | | |
| | Latch Voltage | U_L | Note 3 | V | |
| | Latch Voltage Drift | $\Delta U_L/U_L$ | Note 1 | % | |
| | Reset Voltage | U_R | Note 3 | V | |
| | Reset Voltage Drift | $\Delta U_R/U_R$ | Note 1 | % | |
| Low Level Mechanical Shock | <u>Final Measurements</u> | | | | |
| | Contact Voltage Drop | V_D | Note 3 | V | |
| | Latch Voltage | U_L | Note 3 | V | |
| | Latch Voltage Drift | $\Delta U_L/U_L$ | Note 1 | % | |
| | Reset Voltage | U_R | Note 3 | V | |
| | Reset Voltage Drift | $\Delta U_R/U_R$ | Note 1 | % | |
| | Voltage Proof | VP | Note 3 | Vrms | |
| | Voltage Proof Leakage Current | I_{LVP} | Note 3 | mA | |
| High Level Mechanical Shock | <u>Final Measurements</u> | | | | |
| | Contact Voltage Drop | V_D | Note 3 | V | |
| | Latch Voltage | U_L | Note 3 | V | |
| | Latch Voltage Drift | $\Delta U_L/U_L$ | Note 1 | % | |
| | Reset Voltage | U_R | Note 3 | V | |
| | Reset Voltage Drift | $\Delta U_R/U_R$ | Note 1 | % | |
| | Voltage Proof | VP | Note 3 | Vrms | |
| | Voltage Proof Leakage Current | I_{LVP} | Note 3 | mA | |
| Resistance to Soldering Heat | <u>Final Measurements</u> | | | | |
| | Insulation Resistance | R_I | Note 3 | M Ω | |
| | Contact Voltage Drop | V_D | Note 3 | V | |
| | Latch Voltage | U_L | Note 3 | V | |
| | Reset Voltage | U_R | Note 3 | V | |
| | Coil Resistance | R_B | Note 3 | Ω | |

| Test Reference per ESCC No. 3602 | Characteristics | Symbols | Limits | | Units |
|-------------------------------------|-------------------------------|--------------------|--------|-------------------------|-----------|
| | | | Min | Max | |
| Inductive Life | <u>During Monitoring</u> | | | | |
| | Contact Voltage Drop | V_D | - | 2.8 | V |
| | <u>Final Measurements</u> | | | | |
| | Contact Voltage Drop | V_D | - | $0.015 \times I_{TEST}$ | V |
| | Insulation Resistance | R_I | 50 | - | $M\Omega$ |
| | Voltage Proof: | V_P | | | Vrms |
| | Between latch and reset coils | | 350 | - | |
| | All other points | | 1000 | - | |
| | Voltage Proof Leakage Current | I_{LVP} | | Note 3 | mA |
| | Latch Voltage | U_L | | Note 3 | V |
| | Latch Voltage Drift | $\Delta U_L / U_L$ | | Note 1 | % |
| | Reset Voltage | U_R | | Note 3 | V |
| | Reset Voltage Drift | $\Delta U_R / U_R$ | | Note 1 | % |
| | Latch Time | t_L | | Note 3 | ms |
| | Reset Time | t_R | | Note 3 | ms |
| Bounce Time | t_B | | Note 3 | ms | |
| Coil Resistance | R_B | | Note 3 | Ω | |

| Test Reference per ESCC No. 3602 | Characteristics | Symbols | Limits | | Units |
|-------------------------------------|-------------------------------|--------------------|--------|-------------------------|-----------|
| | | | Min | Max | |
| Resistive Life | <u>During Monitoring</u> | | | | |
| | Contact Voltage Drop | V_D | - | 2.8 | V |
| | <u>Final Measurements</u> | | | | |
| | Contact Voltage Drop | V_D | - | $0.015 \times I_{TEST}$ | V |
| | Insulation Resistance | R_I | 50 | - | $M\Omega$ |
| | Voltage Proof: | V_P | | | Vrms |
| | Between latch and reset coils | | 350 | - | |
| | All other points | | 1000 | - | |
| | Voltage Proof Leakage Current | I_{LVP} | | Note 3 | mA |
| | Latch Voltage | U_L | | Note 3 | V |
| | Latch Voltage Drift | $\Delta U_L / U_L$ | | Note 1 | % |
| | Reset Voltage | U_R | | Note 3 | V |
| | Reset Voltage Drift | $\Delta U_R / U_R$ | | Note 1 | % |
| | Latch Time | t_L | | Note 3 | ms |
| | Reset Time | t_R | | Note 3 | ms |
| | Bounce Time | t_B | | Note 3 | ms |
| Coil Resistance | R_B | | Note 3 | Ω | |

| Test Reference per ESCC No. 3602 | Characteristics | Symbols | Limits | | Units |
|-------------------------------------|--|------------------|--------|-----|-------|
| | | | Min | Max | |
| Coil Life | <u>During Step 1 of each Cycle</u> | | | | |
| | Contact Voltage Drop | V _D | Note 3 | | V |
| | Coil Resistance | R _B | Note 3 | | Ω |
| | <u>During Step 3 of 1st Cycle</u> | | | | |
| | Contact Voltage Drop | V _D | Note 2 | | V |
| | Latch Time | t _E | Note 2 | | ms |
| | Reset Time | t _D | Note 2 | | ms |
| | <u>During Steps 4 & 5 of 4th Cycle</u> | | | | |
| | Latch Voltage | U _L | Note 2 | | V |
| | Reset Voltage | U _R | Note 2 | | V |
| | <u>Final Measurements</u> | | | | |
| | Voltage Proof | VP | Note 3 | | Vrms |
| | Voltage Proof Leakage Current | I _{LVP} | Note 3 | | mA |
| | Insulation Resistance | R _I | Note 3 | | MΩ |
| | Contact Voltage Drop | V _D | Note 3 | | V |
| | Coil Resistance | R _B | Note 3 | | Ω |
| | Latch Time | t _L | Note 3 | | ms |
| | Reset Time | t _R | Note 3 | | ms |
| Bounce Time | t _B | Note 3 | | ms | |

| Test Reference per ESCC No. 3602 | Characteristics | Symbols | Limits | | Units |
|-------------------------------------|-------------------------------|------------------|-------------------------|-------------------------|-------|
| | | | Min | Max | |
| Intermediate Current | <u>During Monitoring</u> | | | | |
| | Contact Voltage Drop: | V_D | | | mV |
| | Pole 1 (15A) | | - | 175 | |
| | Pole 2 (0.5A) | | - | 30 | |
| | Pole 3 (0.3A) | | - | 18 | |
| | Pole 4 (0.1A) | | - | 6 | |
| | <u>Final Measurements</u> | | | | |
| | Insulation Resistance | R_I | 50 | - | MΩ |
| | Voltage Proof: | V_P | | | Vrms |
| | Between latch and reset coils | | 350 | - | |
| | All other points | | 1000 | - | |
| | Voltage Proof Leakage Current | I_{LVP} | | Note 3 | mA |
| | Latch Voltage | U_L | | Note 3 | V |
| | Latch Voltage Drift | $\Delta U_L/U_L$ | | Note 1 | % |
| | Reset Voltage | U_R | | Note 3 | V |
| | Reset Voltage Drift | $\Delta U_R/U_R$ | | Note 1 | % |
| | Latch Time | t_L | | Note 3 | ms |
| Reset Time | t_R | | Note 3 | ms | |
| Bounce Time | t_B | | Note 3 | ms | |
| Coil Resistance | R_B | | Note 3 | Ω | |
| Contact Voltage Drop | V_D | - | $0.015 \times I_{TEST}$ | V | |
| Mechanical Life | <u>Final Measurements</u> | | | | |
| | Contact Voltage Drop | V_D | - | $0.015 \times I_{TEST}$ | V |
| | Latch Voltage | U_L | | Note 3 | V |
| | Latch Voltage Drift | $\Delta U_L/U_L$ | | Note 1 | % |
| | Reset Voltage | U_R | | Note 3 | V |
| | Reset Voltage Drift | $\Delta U_R/U_R$ | | Note 1 | % |
| | Latch Time | t_L | | Note 3 | ms |
| | Reset Time | t_R | | Note 3 | ms |
| | Bounce Time | t_B | | Note 3 | ms |
| Coil Resistance | R_B | | Note 3 | Ω | |

| Test Reference per ESCC No. 3602 | Characteristics | Symbols | Limits | | Units |
|-------------------------------------|-------------------------------|------------------|--------|-------------------------|-----------|
| | | | Min | Max | |
| Overload | <u>During Monitoring</u> | | | | |
| | Contact Voltage Drop | V_D | - | 2.8 | V |
| | <u>Final Measurements</u> | | | | |
| | Contact Voltage Drop | V_D | - | $0.015 \times I_{TEST}$ | V |
| | Insulation Resistance | R_I | 50 | - | $M\Omega$ |
| | Voltage Proof: | V_P | | | Vrms |
| | Between latch and reset coils | | 350 | - | |
| | All other points | | 1000 | - | |
| | Voltage Proof Leakage Current | I_{LVP} | | Note 3 | mA |
| | Latch Voltage | U_L | | Note 3 | V |
| | Latch Voltage Drift | $\Delta U_L/U_L$ | | Note 1 | % |
| | Reset Voltage | U_R | | Note 3 | V |
| | Reset Voltage Drift | $\Delta U_R/U_R$ | | Note 1 | % |
| | Latch Time | t_L | | Note 3 | ms |
| | Reset Time | t_R | | Note 3 | ms |
| Bounce Time | t_B | | Note 3 | ms | |
| Coil Resistance | R_B | | Note 3 | Ω | |

NOTES:

1. Parameter Drift shall be calculated referenced to the measurement immediately prior to the test in question. An additional initial measurement may be performed prior to the test in question if considered necessary. Drift limits are not specified. Drift Values shall be recorded for information purposes only.
2. The limits specified in Para. 2.4.2, as applicable to the same test temperature, shall apply.
3. The limits specified in Para. 2.4.1 shall apply.

2.7 RUN-IN CONDITIONS

The test conditions for Run-in, tested as specified in the ESCC Generic Specification, shall be as follows:

- (a) Test Temperature: $+22 \pm 3^\circ\text{C}$.

APPENDIX A**AGREED DEVIATIONS FOR LEACH INTERNATIONAL EUROPE (F)**

| ITEMS AFFECTED | DESCRIPTION OF DEVIATIONS |
|---|--|
| Para. 1.8.2 Materials and Finishes: Terminals | Terminal material shall be Iron-Cobolt. |
| Para. 2.1.1.1 Deviations from Qualification and Periodic Tests – Chart F4 | High Level Sine Vibration: Not Applicable |
| | High Level Mechanical Shock: Not Applicable |
| | Chart F4: Coil Life subgroup test sequence (under Endurance Subgroup 1): Coil Life and the subsequent tests shall only be performed for Qualification. They are not required for Periodic Testing except in the case of any significant change to the design. |

APPENDIX B
AGREED DEVIATIONS FOR REL STPI (F)

| ITEMS AFFECTED | DESCRIPTION OF DEVIATIONS |
|---|--|
| Para. 2.1.1.1 Deviations from Qualification and Periodic Tests – Chart F4 | Chart F4: Coil Life subgroup test sequence (under Endurance Subgroup 1): Coil Life and the subsequent tests shall only be performed for Qualification. They are not required for Periodic Testing except in the case of any significant change to the design. |