



**RELAY, ELECTROMAGNETIC, LATCHING,
50VDC, 50A, 1PDT**

ESCC Detail Specification No. 3602/014

| | |
|---------|-----------|
| Issue 4 | July 2020 |
|---------|-----------|



LEGAL DISCLAIMER AND COPYRIGHT

European Space Agency, Copyright © 2020. All rights reserved.

The European Space Agency disclaims any liability or responsibility, to any person or entity, with respect to any loss or damage caused, or alleged to be caused, directly or indirectly by the use and application of this ESCC publication.

This publication, without the prior permission of the European Space Agency and provided that it is not used for a commercial purpose, may be:

- copied in whole, in any medium, without alteration or modification.
- copied in part, in any medium, provided that the ESCC document identification, comprising the ESCC symbol, document number and document issue, is removed.

DOCUMENTATION CHANGE NOTICE

(Refer to <https://escies.org> for ESCC DCR content)

| DCR No. | CHANGE DESCRIPTION |
|---------|---|
| 1341 | Specification updated to incorporate changes per DCR. |

TABLE OF CONTENTS

| | | |
|---------|---|----|
| 1 | GENERAL | 5 |
| 1.1 | SCOPE | 5 |
| 1.2 | APPLICABLE DOCUMENTS | 5 |
| 1.3 | TERMS, DEFINITIONS, ABBREVIATIONS, SYMBOLS AND UNITS | 5 |
| 1.4 | THE ESCC COMPONENT NUMBER AND COMPONENT TYPE VARIANTS | 5 |
| 1.4.1 | The ESCC Component Number | 5 |
| 1.4.1.1 | Characteristics and/or Ratings Codes | 5 |
| 1.4.2 | Component Type Variants and Range of Components | 6 |
| 1.5 | MAXIMUM RATINGS | 6 |
| 1.6 | PHYSICAL DIMENSIONS AND TERMINAL IDENTIFICATION | 7 |
| 1.6.1 | Vertical Stud Mount (Variant 01) | 7 |
| 1.6.2 | Horizontal Flange Mount (Variant 04) | 8 |
| 1.7 | FUNCTIONAL DIAGRAM | 9 |
| 1.8 | MATERIALS AND FINISHES | 9 |
| 1.8.1 | Case | 9 |
| 1.8.2 | Terminals | 9 |
| 1.8.3 | Mounting Studs (Variant 01) | 9 |
| 2 | REQUIREMENTS | 9 |
| 2.1 | GENERAL | 9 |
| 2.1.1 | Deviations from the Generic Specification | 9 |
| 2.1.1.1 | Deviations from Special In-Process Controls - Chart F2 | 9 |
| 2.1.1.2 | Deviations from Screening Tests - Chart F3 | 10 |
| 2.1.1.3 | Deviations from Qualification and Periodic Tests - Chart F4 | 10 |
| 2.2 | MARKING | 10 |
| 2.3 | TERMINAL STRENGTH | 10 |
| 2.4 | ELECTRICAL MEASUREMENTS AT ROOM, HIGH AND LOW TEMPERATURES | 11 |
| 2.4.1 | Room Temperature Electrical Measurements | 11 |
| 2.4.2 | High and Low Temperatures Electrical Measurements | 12 |
| 2.4.3 | Notes to Electrical Measurements Tables | 12 |
| 2.5 | PARAMETER DRIFT VALUES | 13 |
| 2.6 | INTERMEDIATE AND END-POINT ELECTRICAL MEASUREMENTS | 13 |
| 2.7 | RUN-IN CONDITIONS | 21 |
| | APPENDIX A | 22 |

1 GENERAL

1.1 SCOPE

This specification details the ratings, physical and electrical characteristics, and test and inspection data for the component type variants and/or the range of components specified below. It supplements the requirements of, and shall be read in conjunction with, the ESCC Generic Specification listed under Applicable Documents.

1.2 APPLICABLE DOCUMENTS

The following documents form part of this specification and shall be read in conjunction with it:

- (a) ESCC Generic Specification No. [3602](#).

1.3 TERMS, DEFINITIONS, ABBREVIATIONS, SYMBOLS AND UNITS

For the purpose of this specification, the terms, definitions, abbreviations, symbols and units specified in ESCC Basic Specification No. [21300](#) shall apply.

1.4 THE ESCC COMPONENT NUMBER AND COMPONENT TYPE VARIANTS

1.4.1 The ESCC Component Number

The ESCC Component Number shall be constituted as follows:

Example: 36020140128V

- Detail Specification Reference: 3602014
- Component Type Variant Number: 01 (as required)
- Characteristic code: Rated Coil Voltage (28Vdc): 28V (as required)

1.4.1.1 *Characteristics and/or Ratings Codes*

Characteristics and/or ratings to be codified as part of the ESCC Component Number shall be as follows:

- (a) Rated Coil Voltage expressed by means of the following codes:

| Rated Coil Voltage (Vdc) | Code |
|--------------------------|------|
| 48 | 48V |
| 28 | 28V |
| 12 | 12V |

1.4.2 Component Type Variants and Range of Components

The component type variants and range of components applicable to this specification are as follows:

| Variant Number | Case Description (Note 1) | Rated Coil Voltage (Vdc) | Weight max (g) |
|----------------|---------------------------|--------------------------|----------------|
| 01 | Vertical 4 Stud Mount | 48, 28, 12 | 150 |
| 04 | Horizontal Flange Mount | 48, 28, 12 | 165 |

NOTES:

1. See Para. 1.6.

1.5 MAXIMUM RATINGS

The maximum ratings shall not be exceeded at any time during use or storage.

Maximum ratings shall only be exceeded during testing to the extent specified in this specification and when stipulated in Test Methods and Procedures of the ESCC Generic Specification.

| Characteristics | Symbols | Maximum Ratings | Units | Remarks |
|--------------------------------------|----------------|--------------------------------------|-------|---|
| Coil Voltage Range | V_{CR} | 45.5 to 55 26.5 to 32 11 to 14 | Vdc | Rated Coil Voltage: 48Vdc Rated Coil Voltage: 28Vdc Rated Coil Voltage: 12Vdc |
| Rated Resistive Load Contact Current | I_{CR} | 50 2 | A | Note 1 Main Contacts; 50Vdc resistive Auxiliary Contacts; 28Vdc resistive |
| Rated Inductive Load Contact Current | I_{CL} | 20 | A | Main Contacts; 50Vdc inductive Note 1 |
| Overload Current | $I_{OVERLOAD}$ | 100 | A | Main Contacts; 50Vdc resistive |
| Terminal Nut Torque | - | 1 0.5 | mN | Main Contact Terminal Studs Mounting Studs (Variant 01) |
| Operating Temperature Range | T_{op} | -65 to +125 | °C | T_{amb} |
| Storage Temperature Range | T_{stg} | -65 to +125 | °C | T_{amb} |
| Soldering Temperature | T_{sol} | +260 | °C | Auxiliary Contact Solder Hook Terminals; Note 2 |

NOTES:

1. Relays should not be used in change-over mode where the potential difference between stationary contacts is greater than 10V and the switched current is greater than 100mA.
2. Duration 10 seconds maximum at a distance not less than 3mm from the device body. The same terminal shall not be resoldered until 3 minutes have elapsed.

1.6 PHYSICAL DIMENSIONS AND TERMINAL IDENTIFICATION

1.6.1 Vertical Stud Mount (Variant 01)

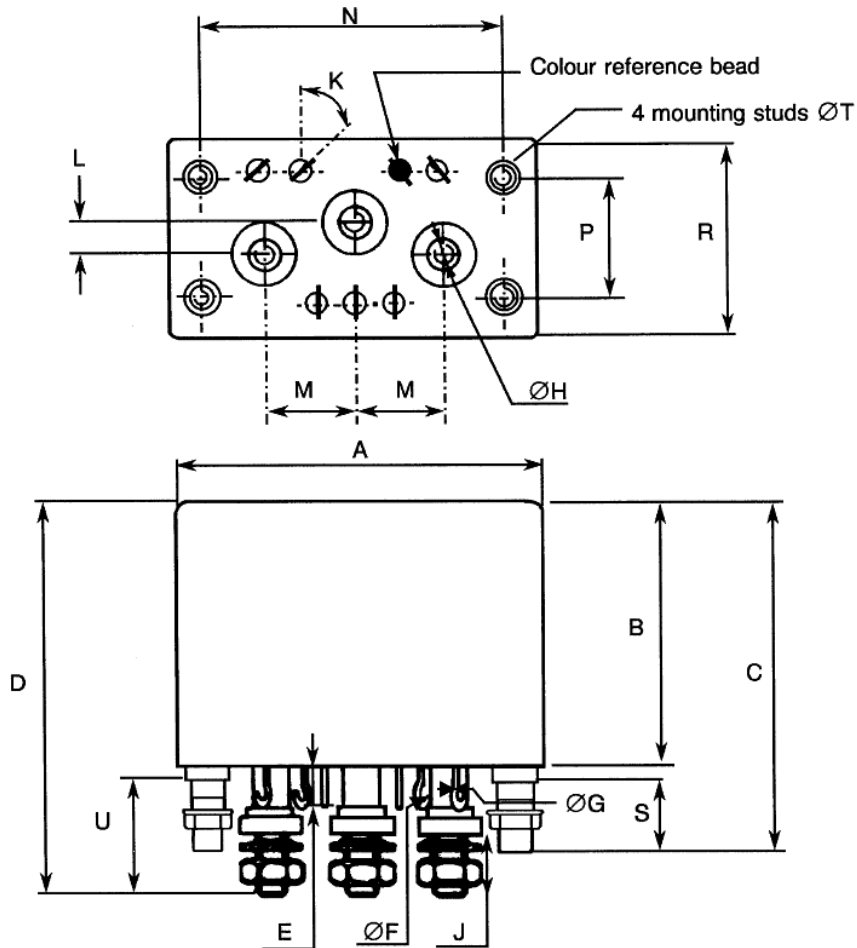

| Symbols | Dimensions (mm) | |
|---------|-----------------|------|
| | Min | Max |
| A | - | 47.8 |
| B | - | 34.6 |
| C | - | 44.7 |
| D | - | 51.6 |
| E | 4.5 | 5.7 |
| ØF | 1.3 | 1.7 |

| Symbols | Dimensions (mm) | |
|---------|-----------------|------|
| | Min | Max |
| ØG | 0.71 | 0.84 |
| ØH | M4 | |
| J | 8.4 | 9.4 |
| K | 40° | 50° |
| L | 3.8 | 4.4 |
| M | 10.9 | 11.5 |

| Symbols | Dimensions (mm) | |
|---------|-----------------|-------|
| | Min | Max |
| N | 37.85 | 38.35 |
| P | 14.8 | 15.35 |
| R | - | 26.2 |
| S | 8.2 | 8.8 |
| ØT | M3 | |
| U | 15 | 16.5 |

NOTES:

- Terminal identification is specified by reference to the colour reference bead and the terminals' configuration. See Para. 1.7.

1.6.2 Horizontal Flange Mount (Variant 04)

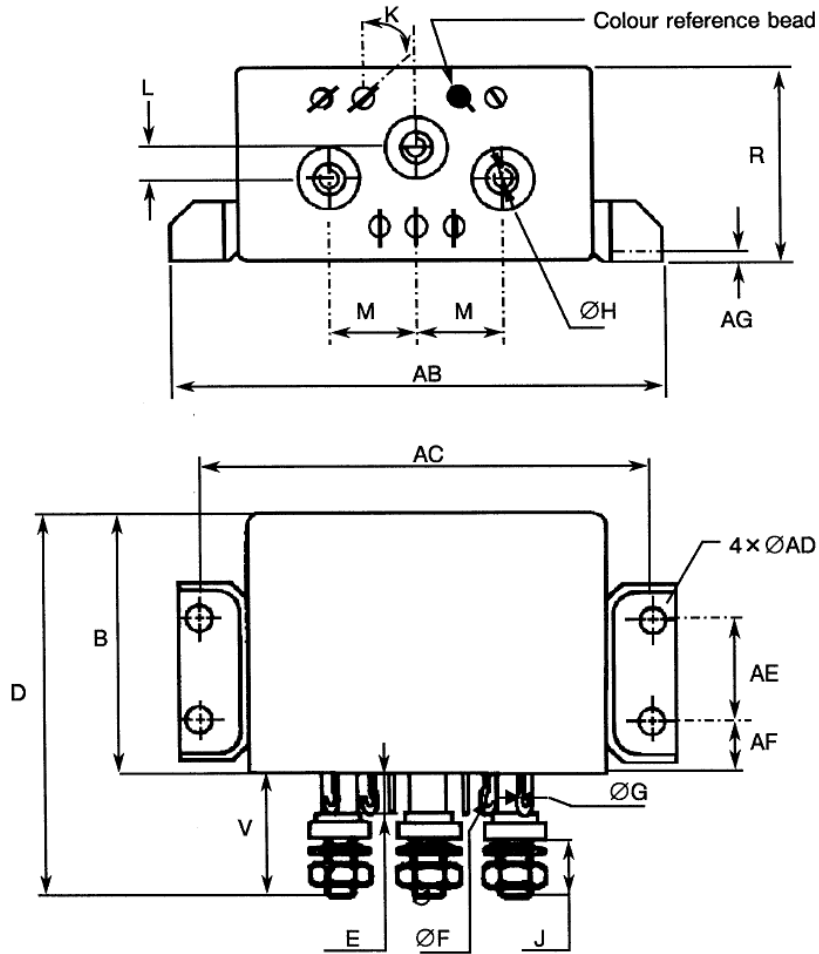

| Symbols | Dimensions (mm) | |
|---------|-----------------|------|
| | Min | Max |
| B | - | 34.6 |
| D | - | 51.6 |
| E | 4.5 | 5.7 |
| ØF | 1.3 | 1.7 |
| ØG | 0.71 | 0.84 |
| ØH | M4 | |

| Symbols | Dimensions (mm) | |
|---------|-----------------|------|
| | Min | Max |
| J | 8.4 | 9.4 |
| K | 40° | 50° |
| L | 3.8 | 4.4 |
| M | 10.9 | 11.5 |
| R | - | 26.2 |
| V | 16.5 | 17.5 |

| Symbols | Dimensions (mm) | |
|---------|-----------------|------|
| | Min | Max |
| AB | - | 70 |
| AC | 60.2 | 60.4 |
| ØAD | 3.1 | 3.5 |
| AE | 15.8 | 16 |
| AF | 6.9 | 7.1 |
| AG | 1.95 | 2.05 |

NOTES:

- Terminal identification is specified by reference to the colour reference bead and the terminals' configuration. See Para. 1.7.

1.7 FUNCTIONAL DIAGRAM

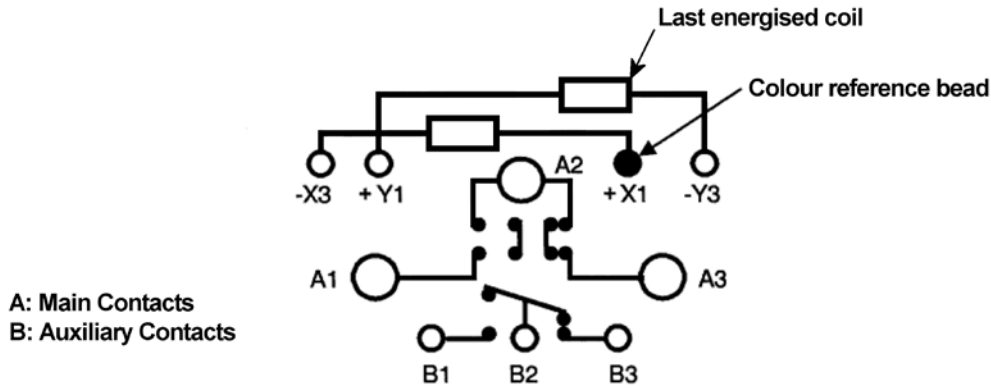

NOTES:

1. As viewed from the terminal side.
2. Individual terminal designations are for reference purposes only.

1.8 MATERIALS AND FINISHES

1.8.1 Case

Copper nickel, tin-lead alloy plated, hermetically sealed.

1.8.2 Terminals

Main contact studs terminal material and finish shall be type H10, and the auxiliary and coil contacts terminal material and finish shall be type F3 or F19, all in accordance with the requirements of ESCC Basic Specification No. [23500](#).

Main contact studs shall be equipped with stainless steel nuts and silver plated beryllium copper washers.

1.8.3 Mounting Studs (Variant 01)

Fe-Ni alloy.

2 REQUIREMENTS

2.1 GENERAL

The complete requirements for procurement of the components specified herein are as stated in this specification and the ESCC Generic Specification. Permitted deviations from the Generic Specification, applicable to this specification only, are listed below.

Permitted deviations from the Generic Specification and this Detail Specification, formally agreed with specific Manufacturers on the basis that the alternative requirements are equivalent to the ESCC requirement and do not affect the component's reliability, are listed in the appendices attached to this specification.

2.1.1 Deviations from the Generic Specification

2.1.1.1 Deviations from Special In-Process Controls - Chart F2

- (a) Seal, Fine Leak: Duration of Pressurisation shall be 5 hours minimum at a pressure of 200kPa.

2.1.1.2 Deviations from Screening Tests - Chart F3

- (a) Vibration Scan : [MIL-STD-202, Test Method 214](#), Test Condition II-E with the following details:
- Method of Mounting: The relays shall be mounted rigidly by normal mounting means.
 - Duration: 1 minute in the latch position and 1 minute in the reset position. Rated Coil Voltage shall be applied only for contact switch over.
 - Vibration direction: In each of three mutually perpendicular directions.
 - Contact Chatter Monitoring: Closed and open contacts shall be monitored per [MIL-STD-202, Test Method 310](#), Test-circuit B, Test Condition A.
- (b) Seal, Fine Leak: Duration of Pressurisation shall be 5 hours minimum at a pressure of 200kPa.

2.1.1.3 Deviations from Qualification and Periodic Tests - Chart F4

- (a) Seal, Fine Leak: Duration of Pressurisation shall be 5 hours minimum at a pressure of 200kPa.
- (b) Low Level Life (& Inductive Life) : Low Level Life shall be performed on auxiliary contacts at the same time and on the same samples being subjected to Inductive Life, with the following details:
- Test Temperature shall be $T_{amb} = +125 (+0 -3)^{\circ}C$.
 - Number of Cycles of Operation of auxiliary contacts shall be 5000.
 - The cycling rate specified for Inductive Life shall be applied.
- (c) Resistive Life: Number of Cycles of Operation shall be 20000 minimum.
- (d) Mechanical Life: Number of Cycles of Operation shall be 90000 minimum.

2.2 MARKING

The marking shall be in accordance with the requirements of ESCC Basic Specification No. [21700](#) and as follows.

The information to be marked on the component shall be:

- (a) The ESCC qualified components symbol (for ESCC qualified components only).
- (b) The ESCC Component Number (see Para. 1.4.1).
- (c) Traceability information.

2.3 TERMINAL STRENGTH

The test conditions for Terminal Strength, tested as specified in the ESCC Generic Specification, shall be as follows:

- (a) Pull Test: Applied Force:
- 15N for auxiliary contact solder hook terminals
 - 160N for main contact terminal studs
 - 50N for mounting studs (Variant 01)
- (b) Torque Test per [MIL-STD-202, Test Method 211](#), Test Condition E with the following details:
- Applied Torque:
- 1.5Nm for main contact terminal studs
 - 0.65Nm for mounting studs (Variant 01)

2.4 ELECTRICAL MEASUREMENTS AT ROOM, HIGH AND LOW TEMPERATURES

Electrical measurements shall be performed at room, high and low temperatures. Consolidated notes are given in Para. 2.4.3.

2.4.1 Room Temperature Electrical Measurements

The measurements shall be performed at $T_{amb} = +22 \pm 3^{\circ}\text{C}$.

| Characteristics | Symbols | Test Method and Conditions | Rated Coil Voltage (Vdc) | Limits | | Units |
|-------------------------------|------------------|--|--------------------------|---------------------------------------|--|-------|
| | | | | Min | Max | |
| Latch Voltage | U _L | ESCC No. 3602 Note 1 | 48 28 12 | 14.3 9.1 3.6 | 24 14 6 | V |
| Reset Voltage | U _R | ESCC No. 3602 Note 1 | 48 28 12 | 14.3 9.1 3.6 | 24 14 6 | V |
| Latch Time | t _L | ESCC No. 3602 | All | - | 20 | ms |
| Reset Time | t _R | ESCC No. 3602 | All | - | 20 | ms |
| Bounce Time | t _B | ESCC No. 3602 | All | - | 2 | ms |
| Insulation Resistance | R _I | ESCC No. 3602 V _{TEST} = 100Vdc | All | 100 | - | MΩ |
| Voltage Proof (Test Voltage) | VP | ESCC No. 3602 Maximum Leakage Current I _{LVP} = 1mA | All | 1250 1000 (Note 2) 500 (Note 3) | - - - | Vrms |
| Voltage Proof Leakage Current | I _{LVP} | ESCC No. 3602 Note 4 | All | - | 1 | mA |
| Contact Voltage Drop | V _D | ESCC No. 3602 Main Contacts: 100mA ≤ I _{TEST} ≤ 10A Auxiliary Contacts: I _{TEST} = 100mA max | All | - - | 0.0025 x I _{TEST} 0.05 x I _{TEST} | V |
| Coil Resistance | R _B | ESCC No. 3602 Both coils | 48 28 12 | 382 130 24 | 486 160 30 | Ω |

2.4.2 High and Low Temperatures Electrical Measurements

| Characteristics | Symbols | Test Method and Conditions | Rated Coil Voltage (Vdc) | Limits | | Units |
|-----------------------|----------------|---|--------------------------|-------------|--|-------|
| | | | | Min | Max | |
| Latch Voltage | U _L | ESCC No. 3602 T _{amb} = +125 (+0 -5)°C and -65 (+5 -0)°C Note 1 | 48 28 12 | - - - | 36 18 9 | V |
| Reset Voltage | U _R | ESCC No. 3602 T _{amb} = +125 (+0 -5)°C and -65 (+5 -0)°C Note 1 | 48 28 12 | - - - | 36 18 9 | V |
| Latch Time | t _L | ESCC No. 3602 T _{amb} = +125 (+0 -5)°C and -65 (+5 -0)°C | All | - | 20 | ms |
| Reset Time | t _R | ESCC No. 3602 T _{amb} = +125 (+0 -5)°C and -65 (+5 -0)°C | All | - | 20 | ms |
| Bounce Time | t _B | ESCC No. 3602 T _{amb} = +125 (+0 -5)°C and -65 (+5 -0)°C | All | - | 2 | ms |
| Insulation Resistance | R _I | ESCC No. 3602 T _{amb} = +125 (+0 -5)°C V _{TEST} = 100Vdc | All | 50 | - | MΩ |
| Contact Voltage Drop | V _D | ESCC No. 3602 T _{amb} = +125 (+0 -5)°C and -65 (+5 -0)°C Main Contacts: 100mA ≤ I _{TEST} ≤ 10A Auxiliary Contacts: I _{TEST} = 100mA max | All | - - | 0.0025 x I _{TEST} 0.05 x I _{TEST} | V |

2.4.3 Notes to Electrical Measurements Tables

1. The coil voltage rise time shall be less than 0.1t_L or 0.1t_R. The coil voltage shall be maintained for a minimum duration of 10t_L or 10t_R.
2. Between coil and case, between open main contacts, between latch and reset coils.
3. Between open auxiliary contacts.
4. Measured during Voltage Proof test.

2.5 PARAMETER DRIFT VALUES

Parameter Drift Values shall be measured as specified in the ESCC Generic Specification.

Unless otherwise specified, the measurements shall be performed at $T_{amb} = +22 \pm 3^{\circ}C$.

The test methods and test conditions shall be as per the corresponding test defined in Para. 2.4.1 Room Temperature Electrical Measurements.

The corresponding absolute limit values for each characteristic shall not be exceeded.

| Characteristics | Symbols | Limits | | | Units |
|-----------------|---------|-------------------------|----------|--------|-------|
| | | Drift Value Δ | Absolute | | |
| | | | Min | Max | |
| Latch Voltage | U_L | Note 1 | Note 2 | Note 2 | V |
| Reset Voltage | U_R | Note 1 | Note 2 | Note 2 | V |

NOTES:

1. Drift Value (Δ) limits are not specified. Drift Values shall be recorded for information purposes only.
2. The limit specified in Para. 2.4.1 shall apply.

2.6 INTERMEDIATE AND END-POINT ELECTRICAL MEASUREMENTS

Unless otherwise specified, the measurements shall be performed at $T_{amb} = +22 \pm 3^{\circ}C$.

Unless otherwise specified the test methods and test conditions shall be as per the corresponding test defined in Para. 2.4.1 Room Temperature Electrical Measurements.

| Test Reference per ESCC No. 3602 | Characteristics (Note 1) | Symbols | Limits | | Units |
|---|-----------------------------|---------|--------|-----|-------|
| | | | Min | Max | |
| Thermal Shock | <u>During 5th Cycle</u> | | | | |
| | Latch Voltage | U_L | Note 2 | | V |
| | Reset Voltage | U_R | Note 2 | | V |
| | Latch Time | t_L | Note 2 | | ms |
| | Reset Time | t_R | Note 2 | | ms |
| | <u>Final Measurements</u> | | | | |
| | Voltage Proof | VP | Note 3 | | Vrms |
| Voltage Proof Leakage Current | I_{LVP} | Note 3 | | mA | |

| Test Reference per ESCC No. 3602 | Characteristics (Note 1) | Symbols | Limits | | Units |
|-------------------------------------|--|------------------|--------|-----|-------|
| | | | Min | Max | |
| Low Level Sine Vibration | <u>Final Measurements</u> | | | | |
| | Latch Voltage | U_L | Note 3 | | V |
| | Latch Voltage Drift | $\Delta U_L/U_L$ | Note 1 | | % |
| | Reset Voltage | U_R | Note 3 | | V |
| | Reset Voltage Drift | $\Delta U_R/U_R$ | Note 1 | | % |
| High Level Sine Vibration | <u>Final Measurements</u> | | | | |
| | Latch Voltage | U_L | Note 3 | | V |
| | Latch Voltage Drift | $\Delta U_L/U_L$ | Note 1 | | % |
| | Reset Voltage | U_R | Note 3 | | V |
| | Reset Voltage Drift | $\Delta U_R/U_R$ | Note 1 | | % |
| Low Level Mechanical Shock | <u>Final Measurements</u> | | | | |
| | Contact Voltage Drop: main contacts | V_D | Note 3 | | V |
| | auxiliary contacts | | Note 3 | | |
| | Latch Voltage | U_L | Note 3 | | V |
| | Latch Voltage Drift | $\Delta U_L/U_L$ | Note 1 | | % |
| | Reset Voltage | U_R | Note 3 | | V |
| | Reset Voltage Drift | $\Delta U_R/U_R$ | Note 1 | | % |
| | Voltage Proof | V_P | Note 3 | | Vrms |
| Voltage Proof Leakage Current | I_{LVP} | Note 3 | | mA | |
| High Level Mechanical Shock | <u>Final Measurements</u> | | | | |
| | Contact Voltage Drop: main contacts | V_D | Note 3 | | V |
| | auxiliary contacts | | Note 3 | | |
| | Latch Voltage | U_L | Note 3 | | V |
| | Latch Voltage Drift | $\Delta U_L/U_L$ | Note 1 | | % |
| | Reset Voltage | U_R | Note 3 | | V |
| | Reset Voltage Drift | $\Delta U_R/U_R$ | Note 1 | | % |
| | Voltage Proof | V_P | Note 3 | | Vrms |
| Voltage Proof Leakage Current | I_{LVP} | Note 3 | | mA | |

| Test Reference per ESCC No. 3602 | Characteristics (Note 1) | Symbols | Limits | | Units |
|---|--|--------------------|------------|-----------------------|-------|
| | | | Min | Max | |
| Resistance to Soldering Heat | <u>Final Measurements</u> | | | | |
| | Insulation Resistance | R_I | Note 3 | | MΩ |
| | Contact Voltage Drop: main contacts | V_D | Note 3 | | V |
| | auxiliary contacts | | Note 3 | | |
| | Latch Voltage | U_L | Note 3 | | V |
| | Reset Voltage | U_R | Note 3 | | V |
| | Coil Resistance | R_B | Note 3 | | Ω |
| Low Level Life (on Auxiliary Contacts only) | <u>Final Measurements</u> | | | | |
| | Contact Voltage Drop: main contacts | V_D | Note 3 | | V |
| | auxiliary contacts | | - | $0.1 \times I_{TEST}$ | |
| | Insulation Resistance | R_I | 50 | - | MΩ |
| | Voltage Proof: between auxiliary contacts | V_P | 500 | - | Vrms |
| | all other points | | 1000 | - | |
| | Voltage Proof Leakage Current | I_{LVP} | Note 3 | | mA |
| | Latch Voltage | U_L | Note 3 | | V |
| | Latch Voltage Drift | $\Delta U_L / U_L$ | Note 1 | | % |
| | Reset Voltage | U_R | Note 3 | | V |
| | Reset Voltage Drift | $\Delta U_R / U_R$ | Note 1 | | % |
| | Latch Time | t_L | Note 3 | | ms |
| | Reset Time | t_R | Note 3 | | ms |
| | Bounce Time | t_B | Note 3 | | ms |
| Coil Resistance | R_B | Note 3 | | Ω | |

| Test Reference per ESCC No. 3602 | Characteristics (Note 1) | Symbols | Limits | | Units |
|--|--|--------------------|--------|-------------------------|-----------|
| | | | Min | Max | |
| Inductive Life (on Main Contacts only) | <u>During Monitoring</u> | | | | |
| | Contact Voltage Drop: main contacts | V_D | - | 5 | V |
| | <u>Final Measurements</u> | | | | |
| | Contact Voltage Drop: main contacts | V_D | - | $0.003 \times I_{TEST}$ | V |
| | auxiliary contacts | | | Note 3 | |
| | Insulation Resistance | R_i | 50 | - | $M\Omega$ |
| | Voltage Proof: | V_P | | | Vrms |
| | between auxiliary contacts | | 500 | - | |
| | all other points | | 1000 | - | |
| | Voltage Proof Leakage Current | I_{LVP} | | Note 3 | mA |
| | Latch Voltage | U_L | | Note 3 | V |
| | Latch Voltage Drift | $\Delta U_L / U_L$ | | Note 1 | % |
| | Reset Voltage | U_R | | Note 3 | V |
| | Reset Voltage Drift | $\Delta U_R / U_R$ | | Note 1 | % |
| | Latch Time | t_L | | Note 3 | ms |
| Reset Time | t_R | | Note 3 | ms | |
| Bounce Time | t_B | | Note 3 | ms | |
| Coil Resistance | R_B | | Note 3 | Ω | |

| Test Reference per ESCC No. 3602 | Characteristics (Note 1) | Symbols | Limits | | Units |
|-------------------------------------|-------------------------------|--------------------|--------|-------------------------|------------------|
| | | | Min | Max | |
| Resistive Life | <u>During Monitoring</u> | | | | |
| | Contact Voltage Drop: | V_D | - | 5 | V |
| | main contacts | | - | 2.8 | |
| | auxiliary contacts | | | | |
| | <u>Final Measurements</u> | | | | |
| | Contact Voltage Drop: | V_D | - | $0.003 \times I_{TEST}$ | V |
| | main contacts | | - | $0.1 \times I_{TEST}$ | |
| | auxiliary contacts | | | | |
| | Insulation Resistance | R_I | 50 | - | M Ω |
| | Voltage Proof: | V_P | | | V _{rms} |
| | between auxiliary contacts | | 500 | - | |
| | all other points | | 1000 | - | |
| | Voltage Proof Leakage Current | I_{LVP} | | Note 3 | mA |
| | Latch Voltage | U_L | | Note 3 | V |
| | Latch Voltage Drift | $\Delta U_L / U_L$ | | Note 1 | % |
| | Reset Voltage | U_R | | Note 3 | V |
| Reset Voltage Drift | $\Delta U_R / U_R$ | | Note 1 | % | |
| Latch Time | t_L | | Note 3 | ms | |
| Reset Time | t_R | | Note 3 | ms | |
| Bounce Time | t_B | | Note 3 | ms | |
| Coil Resistance | R_B | | Note 3 | Ω | |

| Test Reference per ESCC No. 3602 | Characteristics (Note 1) | Symbols | Limits | | Units |
|-------------------------------------|--|------------------|------------------|-----|------------------|
| | | | Min | Max | |
| Coil Life | <u>During Step 1 of each Cycle</u> | | | | |
| | Contact Voltage Drop: main contacts auxiliary contacts | V _D | Note 3 Note 3 | | V |
| | Coil Resistance | R _B | Note 3 | | Ω |
| | <u>During Step 3 of 1st Cycle</u> | | | | |
| | Contact Voltage Drop | V _D | Note 2 | | V |
| | Latch Time | t _E | Note 2 | | ms |
| | Reset Time | t _D | Note 2 | | ms |
| | <u>During Steps 4 & 5 of 4th Cycle</u> | | | | |
| | Latch Voltage | U _L | Note 2 | | V |
| | Reset Voltage | U _R | Note 2 | | V |
| | <u>Final Measurements</u> | | | | |
| | Voltage Proof | VP | Note 3 | | V _{rms} |
| | Voltage Proof Leakage Current | I _{LVP} | Note 3 | | mA |
| | Insulation Resistance | R _I | Note 3 | | MΩ |
| | Contact Voltage Drop: main contacts auxiliary contacts | V _D | Note 3 Note 3 | | V |
| | Coil Resistance | R _B | Note 3 | | Ω |
| | Latch Time | t _L | Note 3 | | ms |
| | Reset Time | t _R | Note 3 | | ms |
| | Bounce Time | t _B | Note 3 | | ms |

| Test Reference per ESCC No. 3602 | Characteristics (Note 1) | Symbols | Limits | | Units |
|-------------------------------------|-------------------------------|------------------|-------------------------|----------|------------|
| | | | Min | Max | |
| Intermediate Current | <u>During Monitoring</u> | | | | |
| | Contact Voltage Drop: | V_D | | | mV |
| | main contacts | | - | 200 | |
| | auxiliary contacts | | - | 300 | |
| | <u>Final Measurements</u> | | | | |
| | Insulation Resistance | R_I | 50 | - | M Ω |
| | Voltage Proof: | V_P | | | Vrms |
| | between auxiliary contacts | | 500 | - | |
| | all other points | | 1000 | - | |
| | Voltage Proof Leakage Current | I_{LVP} | | Note 3 | mA |
| | Latch Voltage | U_L | | Note 3 | V |
| | Latch Voltage Drift | $\Delta U_L/U_L$ | | Note 1 | % |
| | Reset Voltage | U_R | | Note 3 | V |
| | Reset Voltage Drift | $\Delta U_R/U_R$ | | Note 1 | % |
| | Latch Time | t_L | | Note 3 | ms |
| | Reset Time | t_R | | Note 3 | ms |
| | Bounce Time | t_B | | Note 3 | ms |
| Coil Resistance | R_B | | Note 3 | Ω | |
| Contact Voltage Drop: | V_D | | | V | |
| main contacts | | - | $0.003 \times I_{TEST}$ | | |
| auxiliary contacts | | - | $0.1 \times I_{TEST}$ | | |

| Test Reference per ESCC No. 3602 | Characteristics (Note 1) | Symbols | Limits | | Units |
|-------------------------------------|--|--------------------|--------|-------------------------|------------|
| | | | Min | Max | |
| Mechanical Life | <u>Final Measurements</u> | | | | |
| | Contact Voltage Drop: main contacts | V_D | - | $0.003 \times I_{TEST}$ | V |
| | auxiliary contacts | | - | $0.1 \times I_{TEST}$ | |
| | Latch Voltage | U_L | Note 3 | | V |
| | Latch Voltage Drift | $\Delta U_L / U_L$ | Note 1 | | % |
| | Reset Voltage | U_R | Note 3 | | V |
| | Reset Voltage Drift | $\Delta U_R / U_R$ | Note 1 | | % |
| | Latch Time | t_L | Note 3 | | ms |
| | Reset Time | t_R | Note 3 | | ms |
| | Bounce Time | t_B | Note 3 | | ms |
| Coil Resistance | R_B | Note 3 | | Ω | |
| Overload | <u>During Monitoring</u> | | | | |
| | Contact Voltage Drop: main contacts | V_D | - | 5 | V |
| | auxiliary contacts | | - | 1.4 | |
| | <u>Final Measurements</u> | | | | |
| | Contact Voltage Drop: main contacts | V_D | - | $0.003 \times I_{TEST}$ | V |
| | auxiliary contacts | | - | $0.1 \times I_{TEST}$ | |
| | Insulation Resistance | R_I | 50 | - | M Ω |
| | Voltage Proof: between auxiliary contacts | V_P | 500 | - | Vrms |
| | all other points | | 1000 | - | |
| | Voltage Proof Leakage Current | I_{LVP} | Note 3 | | mA |
| | Latch Voltage | U_L | Note 3 | | V |
| | Latch Voltage Drift | $\Delta U_L / U_L$ | Note 1 | | % |
| | Reset Voltage | U_R | Note 3 | | V |
| | Reset Voltage Drift | $\Delta U_R / U_R$ | Note 1 | | % |
| | Latch Time | t_L | Note 3 | | ms |
| Reset Time | t_R | Note 3 | | ms | |
| Bounce Time | t_B | Note 3 | | ms | |
| Coil Resistance | R_B | Note 3 | | Ω | |

NOTES:

1. Parameter Drift shall be calculated referenced to the measurement immediately prior to the test in question. An additional initial measurement may be performed prior to the test in question if considered necessary. Drift limits are not specified. Drift Values shall be recorded for information purposes only.
2. The limits specified in Para. 2.4.2, as applicable to the same test temperature, shall apply.
3. The limits specified in Para. 2.4.1 shall apply.

2.7 RUN-IN CONDITIONS

The test conditions for Run-in, tested as specified in the ESCC Generic Specification, shall be as follows:

- (a) Test Temperature: $+22 \pm 3^{\circ}\text{C}$.

APPENDIX A
AGREED DEVIATIONS FOR REL STPI (F)

| ITEMS AFFECTED | DESCRIPTION OF DEVIATIONS |
|---|--|
| Para. 2.1.1.3 Deviations from Qualification and Periodic Tests - Chart F4 | High Level Sine Vibration: Not Applicable |
| | High Level Mechanical Shock: Not Applicable |
| | Chart F4: Coil Life subgroup test sequence (under Endurance Subgroup 1): Coil Life and the subsequent tests shall only be performed for Qualification. They are not required for Periodic Testing except in the case of any significant change to the design. |