



**EXTERNAL VISUAL INSPECTION OF
ELECTROMAGNETIC RELAYS**

ESCC Basic Specification No. 2053600

Issue 2	February 2014
---------	---------------



LEGAL DISCLAIMER AND COPYRIGHT

European Space Agency, Copyright © 2014. All rights reserved.

The European Space Agency disclaims any liability or responsibility, to any person or entity, with respect to any loss or damage caused, or alleged to be caused, directly or indirectly by the use and application of this ESCC publication.

This publication, without the prior permission of the European Space Agency and provided that it is not used for a commercial purpose, may be:

- copied in whole, in any medium, without alteration or modification.
- copied in part, in any medium, provided that the ESCC document identification, comprising the ESCC symbol, document number and document issue, is removed.

DOCUMENTATION CHANGE NOTICE

(Refer to <https://escies.org> for ESCC DCR content)

DCR No.	CHANGE DESCRIPTION
838	Specification upissued to incorporate editorial changes per DCR.

**TABLE OF CONTENTS**

1	SCOPE	5
2	GENERAL REQUIREMENTS	5
2.1	APPLICABILITY	5
2.2	PROCEDURE	5
3	EQUIPMENT REQUIRED	5
3.1	MAGNIFICATION	5
3.2	MOUNTING FIXTURES	5
4	DETAILED REQUIREMENTS	5
4.1	REJECT CRITERIA	5
4.2	LEADS	5
4.2.1	Lead Condition	5
4.2.2	Lead Configuration	6
4.3	TERMINALS	6
4.4	GLASS SEALS	6
4.5	HEADERS	6
4.6	CASE OR PACKAGE SEALING	6
4.7	CASE CONCENTRICITY	6
5	FIGURES	7
5.1	FIGURE 1: LEAD ECCENTRICITY	7
5.2	FIGURE 2: LEAD TILT	7
5.3	FIGURE 3: CASE CONCENTRICITY	8

1 **SCOPE**

This Specification to be read in conjunction with ESCC Basic Specification No. [20500](#), External Visual Inspection, contains additional specific requirements for Electromagnetic Relays.

2 **GENERAL REQUIREMENTS**

2.1 **APPLICABILITY**

The following criteria may not be varied or modified after commencing an inspection stage. Any ambiguity or proposed minor deviation shall be referred to the ESCC Executive for resolution and approval.

2.2 **PROCEDURE**

All items shall be examined in such a manner that a minimum of handling and movement of the component is involved.

3 **EQUIPMENT REQUIRED**

3.1 **MAGNIFICATION**

All items shall be examined using a binocular or stereoscopic microscope with a minimum range of magnification X8 to X20. Minimum magnification shall be X8. maximum magnification shall be X20.

3.2 **MOUNTING FIXTURES**

Suitable fixtures may be used to assist in the inspection process, provided that they do not themselves cause damage to the device. Care shall be taken that adequate provision is made to avoid accidental damage.

4 **DETAILED REQUIREMENTS**

4.1 **REJECT CRITERIA**

A component shall be rejected if it exhibits one or more of the defects listed in any of the following paragraphs. Where applicable, drawings have been included to provide additional explanatory material, but they shall be considered as examples only.

4.2 **LEADS**

4.2.1 **Lead Condition**

- (a) Exposed base material, in excess of lead diameter or thickness, caused by chipped glass meniscus.
- (b) Exposed base material anywhere on the lead within a distance of 20mm of the case, other than that caused by (a).
- (c) Exposed base material in excess of 5% of the surface area anywhere on the lead, beyond a distance of 20mm from the case.
- (d) Non-conductive material on the lead, beyond a distance of 1.5mm from the case.
- (e) Reduction of lead diameter, width or thickness by more than 10% within 20mm of the case.
- (f) Nicks, fractures, non-uniformity or discolouration of coating or abrasions exposing base material.

4.2.2 Lead Configuration

- (a) Straight round leads twisted more than 1 revolution per 30mm of length.
- (b) Leads kinked or bent and re-bent within 20mm of the case.
- (c) Lead deviating from the specified direction by more than 1mm per any 5mm of length.
- (d) Eccentricity of lead passing through centre of glass-to-metal seal greater than 10% of the seal diameter (see Figure 1 Para. 5.1).
- (e) Lead tilted by more than five degrees (5°) (see Figure 2 Para. 5.2).

4.3 TERMINALS

- (a) At least 95% of the terminals shall be covered by a protective plating as defined in the Detail Specification.
- (b) Terminals shall be perpendicular to headers (gauge).

4.4 GLASS SEALS

- (a) Filling, in glass-filled cases, protruding above the level of the case flange.
- (b) Single bubbles in a glass seal, the diameter of the minor ones of which exceeds one eighth of the seal diameter, or a collection of smaller bubbles which cannot be separated from each other or whose spatial distribution cannot be determined.
- (c) Foreign material embedded in the glass seal.
- (d) Surface chips, the diameter of which exceeds in any one place 20% of the glass seal diameter or whose depth is greater than one quarter of the header thickness.
- (e) Cracks of any shape, length or position.
- (f) Incomplete wetting of terminal by glass.

4.5 HEADERS

- (a) At least 98% of the headers shall be covered by a protective plating as defined in the Detail Specification.
- (b) Header/can junctions shall be free from voids or pits.
- (c) Tinning shall be smooth and bright.

4.6 CASE OR PACKAGE SEALING

- (a) Lack of solder continuity around the complete perimeter of the case or solder protruding beyond the edge of the case.
- (b) Weld spatters, lack of uniformity or continuity of weld.
- (c) Reduction of design sealing area by more than 20% due to undercutting of sealing material or misalignment of case parts.

4.7 CASE CONCENTRICITY

- (a) Minimum case perimeter to header perimeter clearance, in plan view, less than 70% of the maximum clearance (see Figure 3 Para. 5.3).

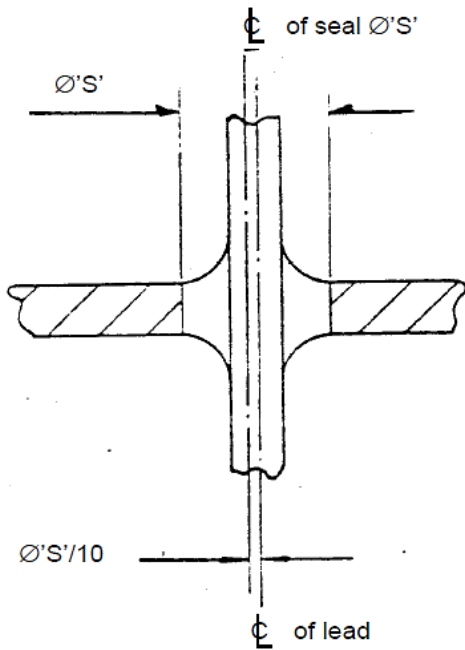
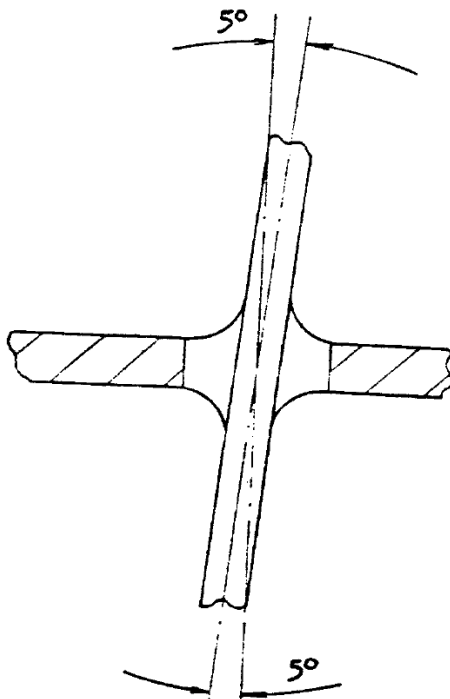
5 FIGURES**5.1 FIGURE 1: LEAD ECCENTRICITY****5.2 FIGURE 2: LEAD TILT**

5.3 FIGURE 3: CASE CONCENTRICITY

