



**CONNECTOR SAVERS, ELECTRICAL,
RECTANGULAR, MINIATURE, REMOVABLE
CONTACTS**

BASED ON TYPE D*BMA

ESCC Detail Specification No. 3401/020

Issue 8	September 2015
---------	----------------



LEGAL DISCLAIMER AND COPYRIGHT

European Space Agency, Copyright © 2015. All rights reserved.

The European Space Agency disclaims any liability or responsibility, to any person or entity, with respect to any loss or damage caused, or alleged to be caused, directly or indirectly by the use and application of this ESCC publication.

This publication, without the prior permission of the European Space Agency and provided that it is not used for a commercial purpose, may be:

- copied in whole, in any medium, without alteration or modification.
- copied in part, in any medium, provided that the ESCC document identification, comprising the ESCC symbol, document number and document issue, is removed.

DOCUMENTATION CHANGE NOTICE

(Refer to <https://escies.org> for ESCC DCR content)

DCR No.	CHANGE DESCRIPTION
937	Specification upissued to incorporate technical changes per DCR.

TABLE OF CONTENTS

1	GENERAL	6
1.1	SCOPE	6
1.2	RANGE OF COMPONENTS AND COMPONENT TYPE VARIANTS	6
1.3	MAXIMUM RATINGS	6
1.4	PARAMETER DERATING INFORMATION	6
1.5	PHYSICAL DIMENSIONS	6
2	APPLICABLE DOCUMENTS	6
3	TERMS, DEFINITIONS, ABBREVIATIONS, SYMBOLS AND UNITS	7
4	REQUIREMENTS	11
4.1	GENERAL	11
4.2	DEVIATIONS FROM GENERIC SPECIFICATION	11
4.2.1	Deviations from Special In-Process Controls	11
4.2.2	Deviations from Final Production Tests (Chart II)	11
4.2.3	Deviations from Burn-in and Electrical Measurements (Chart III)	11
4.2.4	Deviations from Qualification Tests (Chart IV)	11
4.2.5	Deviations from Lot Acceptance Tests (Chart V)	11
4.3	MECHANICAL REQUIREMENTS	11
4.3.1	Dimension Check	11
4.3.2	Weight	11
4.3.3	Contact Capability	11
4.3.4	Contact Retention (in Insert)	11
4.3.5	Mating and Unmating Forces	12
4.3.6	Insert Retention (in Shell)	12
4.3.7	Jackscrew Retention	12
4.3.8	Contact Insertion and Withdrawal Forces	12
4.3.9	Engagement and Separation Forces	12
4.3.10	Oversize Pin Exclusion	12
4.3.11	Probe Damage	12
4.3.12	Solderability	12
4.4	MATERIALS AND FINISHES	12
4.4.1	Shells	12
4.4.2	Inserts	12
4.4.3	Spacers	12
4.4.4	Contacts	12
4.4.5	Contact Retaining Clip	13

4.4.6	Guiding and Locking Devices	13
4.4.7	Magnetism Level	13
4.5	MARKING	13
4.5.1	General	13
4.5.2	Contact Identification	13
4.5.3	The ESCC Component Number	13
4.5.4	Characteristics	14
4.5.4.1	Series	14
4.5.4.2	Shell Size	14
4.5.4.3	Insert Type	14
4.5.4.4	Contact Arrangements	14
4.5.4.5	Type of Contact	15
4.5.4.6	Magnetism Level	15
4.5.4.7	Modification Code	15
4.5.4.8	Contact Information	15
4.5.5	Traceability Information	15
4.6	ELECTRICAL MEASUREMENTS	15
4.6.1	Electrical Measurements at Room Temperature	15
4.6.2	Electrical Measurements at High and Low Temperatures (Table 3)	15
4.6.3	Circuit for Electrical Measurements (Figure 4)	15
4.7	BURN-IN AND ELECTRICAL MEASUREMENTS (TABLES 4 AND 5)	15
4.8	ENVIRONMENTAL AND ENDURANCE TESTS (CHARTS IV AND V OF ESCC GENERIC SPECIFICATION NO. 3401)	16
4.8.1	Measurements and Inspections on Completion of Environmental Tests	16
4.8.2	Measurements and Inspections at Intermediate Points during Endurance Tests	16
4.8.3	Measurements and Inspections on Completion of Endurance Tests	16
4.8.4	Conditions for Operating Life Test (Part of Endurance Testing)	16
4.8.5	Electrical Circuit for Operating Life Test (Figure 5)	16
4.8.6	Conditions for High Temperature Storage Test (Part of Endurance Testing)	16
	APPENDIX 'A'	21
	APPENDIX 'B'	22

1 GENERAL

1.1 SCOPE

This specification details the ratings, physical and electrical characteristics, test and inspection data for Connector Savers, Electrical, Rectangular, with Removable Contacts, Standard (Gauge 20) and High Density (Gauge 22) Contact Arrangements, based on type D*BMA.

It shall be read in conjunction with:

- (a) ESCC Generic Specification No. 3401, Connectors, Electrical, Non-Filtered, Circular and Rectangular.
- (b) ESCC Detail Specification No. 3401/021, Contacts, Electrical, Male/Female Type, for 3401/020 Connector Savers.
- (c) ESCC Detail Specification No. 3401/022, Accessories for Rectangular Connectors, 3401/001, 3401/002 and Connector Savers 3401/020, 3401/080.
- (d) ESCC Detail Specification No. 3401/085, Fast-Locking Screw Lock Assemblies for Rectangular Connectors 3401/001, 3401/002 and Connector Savers 3401/020, 3401/080.

the requirements of which are supplemented herein.

1.2 RANGE OF COMPONENTS AND COMPONENT TYPE VARIANTS

The different sizes of connector savers specified herein, together with their mechanical characteristics, are given in Table 1(a).

1.3 MAXIMUM RATINGS

The maximum ratings, which shall not be exceeded at any time during use or storage, applicable to the connector savers specified herein, are scheduled in Table 1(b).

1.4 PARAMETER DERATING INFORMATION

The applicable derating information for the connector savers specified herein is shown in Figure 1.

1.5 PHYSICAL DIMENSIONS

The physical dimensions of the connector savers specified herein and the available contact arrangements are shown in Figure 2.

2 APPLICABLE DOCUMENTS

The following documents form part of this specification and shall be read in conjunction with it:

- (a) ESCC Generic Specification No. 3401, Connectors, Electrical, Non-Filtered, Circular and Rectangular.
- (b) ESCC Detail Specification No. 3401/021, Contacts, Electrical, Male/Female Type, for 3401/020 Connector Savers.
- (c) ESCC Detail Specification No. 3401/022, Accessories for Rectangular Connectors 3401/001, 3401/002 and Connector Savers 3401/020, 3401/080.
- (d) ESCC Detail Specification No. 3401/085, Fast-Locking Screw Lock Assemblies for Rectangular Connectors 3401/001, 3401/002 and Connector Savers 3401/020, 3401/080.
- (e) MIL-DTL-24308, Rack and Panel Connectors, Miniature.

3 TERMS, DEFINITIONS, ABBREVIATIONS, SYMBOLS AND UNITS

For the purpose of this specification, the terms, definitions, abbreviations, symbols and units specified in ESCC Basic Specification No. 21300 shall apply.

TABLE 1(a) - RANGE OF COMPONENTS AND TYPE VARIANTS

Shell Size (1)	Max. Weight (g) (2)		Mating Force (N. max)		Unmating Force			
					N. min		N. max	
	Var. 01 (3)	Var. 02 (4)	Var. 01 (3)	Var. 02 (4)	Var. 01 (3)	Var. 02 (4)	Var. 01 (3)	Var. 02 (4)
E	9.9	9.5	30	46	3.5	3.4	20	28
A	13.7	13.2	50	77	4.5	4.5	34	46
B	18.4	17.8	83	127	8	7.9	55	77
C	23.9	23.2	123	177	11	11.3	83	109
D	26.8	26.1	166	222	14.5	14.7	120	136
F	-	32	-	295	-	20.3	-	177

NOTES:

1. See Figure 2(a).
2. Without contacts. See ESCC Detail specification No. 3401/021 for contact weights.
3. Standard contact arrangements.
4. High density contact arrangements.

TABLE 1(b) - MAXIMUM RATINGS

No.	Characteristics	Symbol	Maximum Rating	Unit	Remarks
1	Working Voltage (Sea Level) Variant 01 Variant 02	U_R	300 250	Vrms Vrms	
2	Operating Temperature Range	T_{op}	-55 to +125	°C	T_{amb}
3	Storage Temperature Range	T_{stg}	-65 to +125	°C	-

FIGURE 1 - PARAMETER DERATING INFORMATION

Voltage Proof versus Altitude

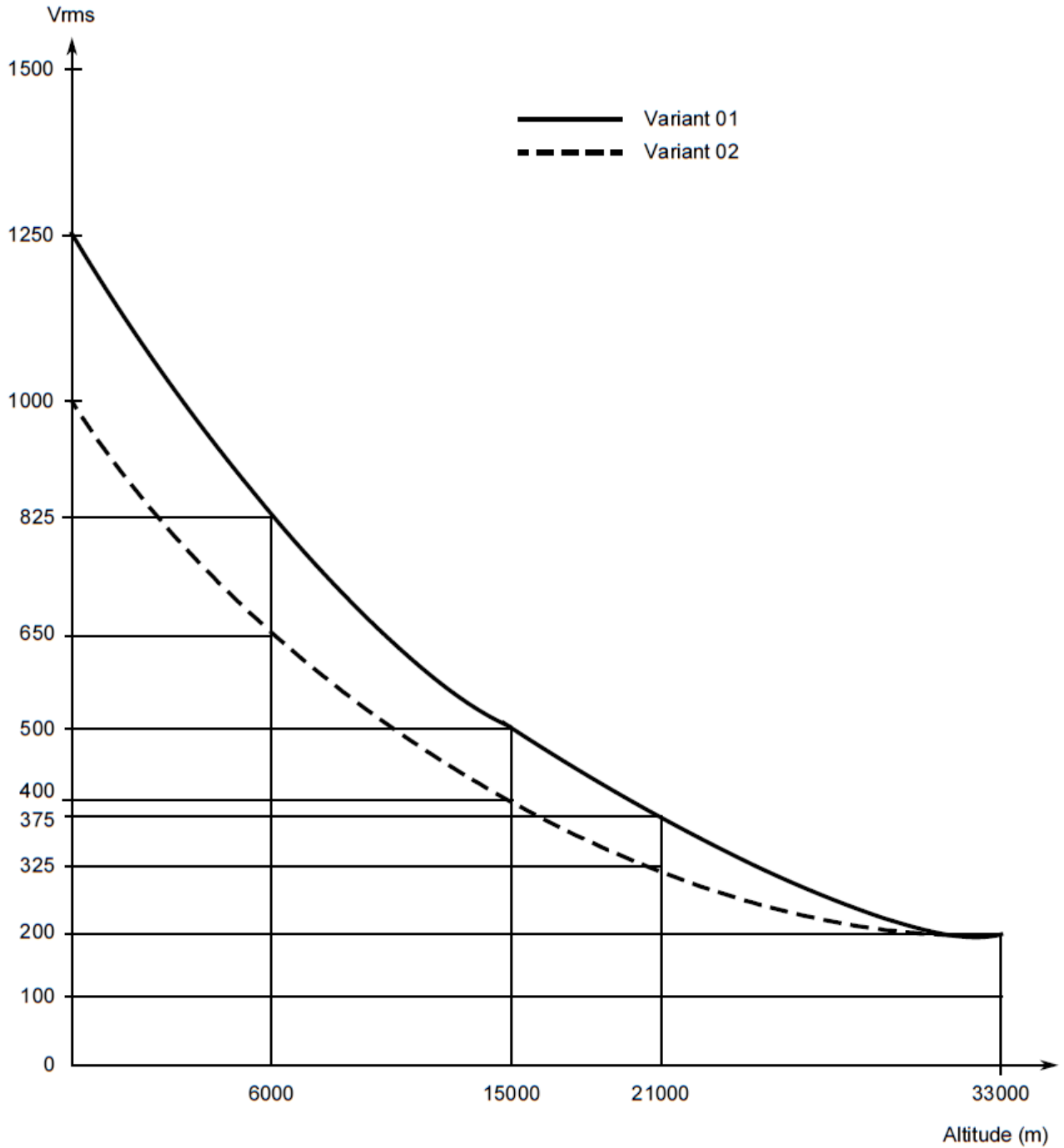
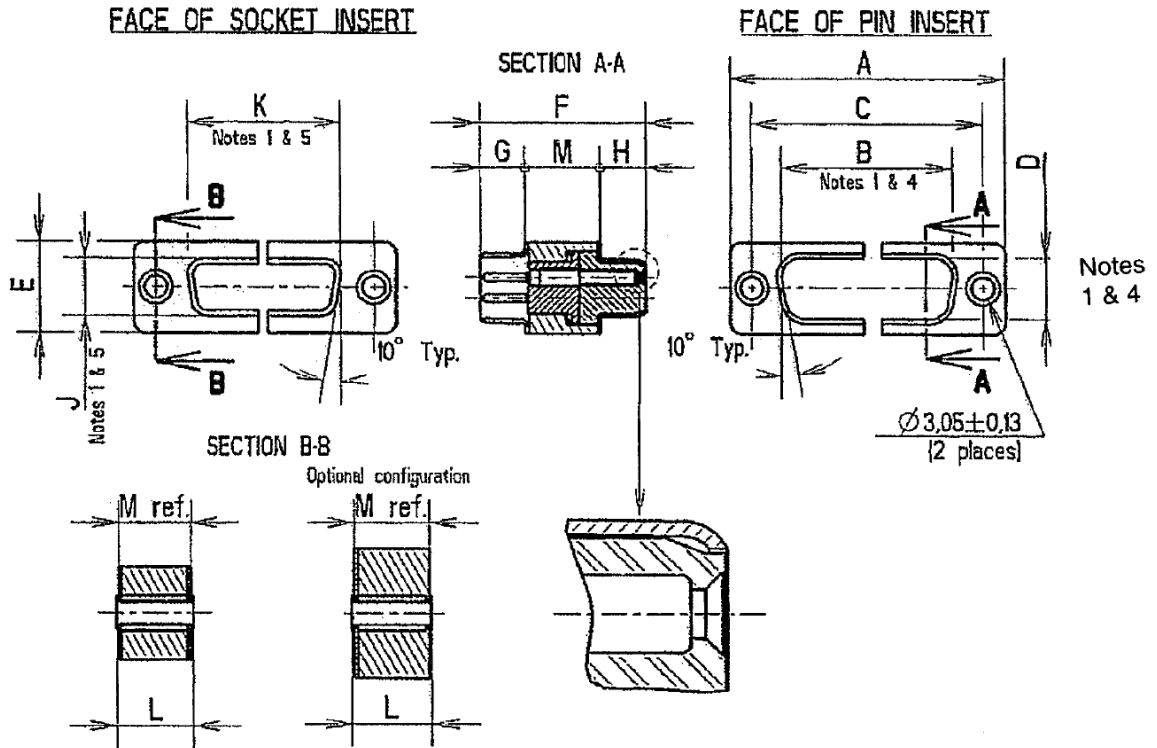

FIGURE 2 - PHYSICAL DIMENSIONS

FIGURE 2(a) - CONNECTOR SAVERS



Shell Size	Dimensions	<u>A</u>	<u>B</u>	<u>C</u>	D	E	F	<u>G</u>	<u>H</u>	<u>J</u>	<u>K</u>	L	M
E	Min.	30.43	16.79	24.87	8.23	12.17	21.62	5.82	6.05	7.77	16.21	10.21	9.61
	Max.	31.19	17.04	25.12	8.48	12.93	22.12	6.05	6.3	8.03	16.46	10.97	10.11
A	Min.	38.76	25.12	33.2	8.23	12.17	21.62	5.82	6.05	7.77	24.54	10.21	9.61
	Max.	39.52	25.37	33.45	8.48	12.93	22.12	6.05	6.3	8.03	24.79	10.97	10.11
B	Min.	52.65	38.84	46.91	8.23	12.17	21.72	5.69	6.05	7.77	38.25	10.21	9.61
	Max.	53.42	39.09	47.17	8.48	12.93	22.22	5.99	6.3	8.03	38.51	10.97	10.11
C	Min.	68.94	55.3	63.37	8.23	12.17	21.72	5.69	6.05	7.77	54.71	10.21	9.61
	Max.	69.7	55.55	63.63	8.48	12.93	22.22	5.99	6.3	8.03	54.97	10.97	10.11
D	Min.	66.55	52.68	60.99	11.07	14.99	21.72	5.69	6.05	10.62	52.3	10.21	9.61
	Max.	67.31	52.93	61.24	11.33	15.75	22.22	5.99	6.3	10.87	52.55	10.97	10.11
F	Min.	68.94	56.06	63.37	12.65	16.92	21.72	5.69	6.05	12.19	55.47	10.21	9.61
	Max.	69.7	56.31	63.63	12.9	17.68	22.22	5.99	6.3	12.45	55.73	10.97	10.11

NOTES:

1. Dimensions B, D, J and K pertain to front and rear shell keystone and are taken at bottom of draw.
2. All dimensions are in millimetres (angles in degrees).
3. Underlined dimensions, in Table, are critical to ensure mateability.
4. Inside dimension for male side.
5. Outside dimension for female side.

FIGURE 2(b) - CONTACT ARRANGEMENTS

VARIANT 01 - STANDARD CONTACT ARRANGEMENTS (FRONT VIEW MALE INSERT)

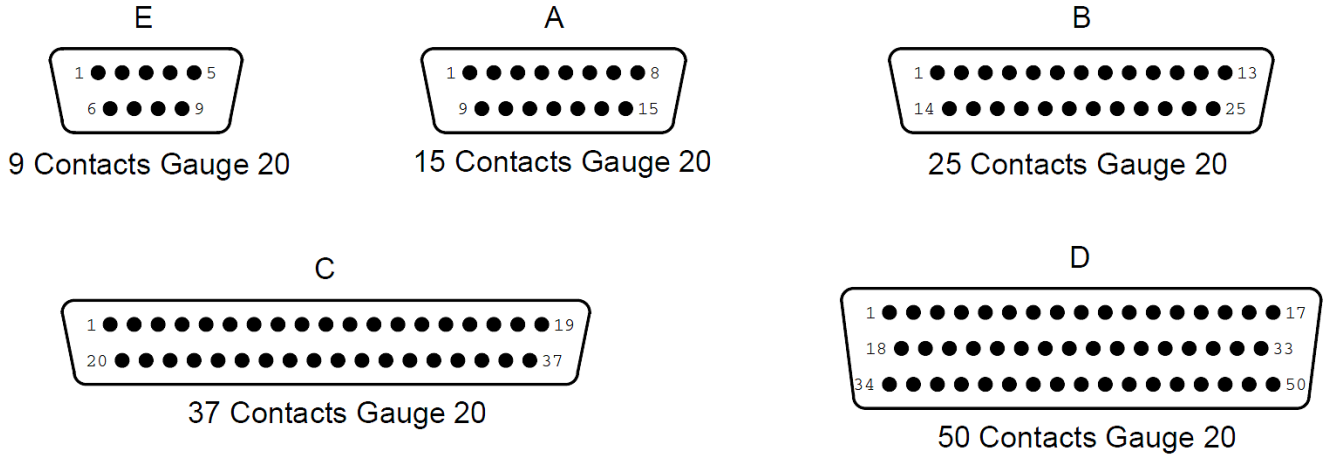

VARIANT 02 - HIGH DENSITY CONTACT ARRANGEMENTS (FRONT VIEW MALE INSERT)

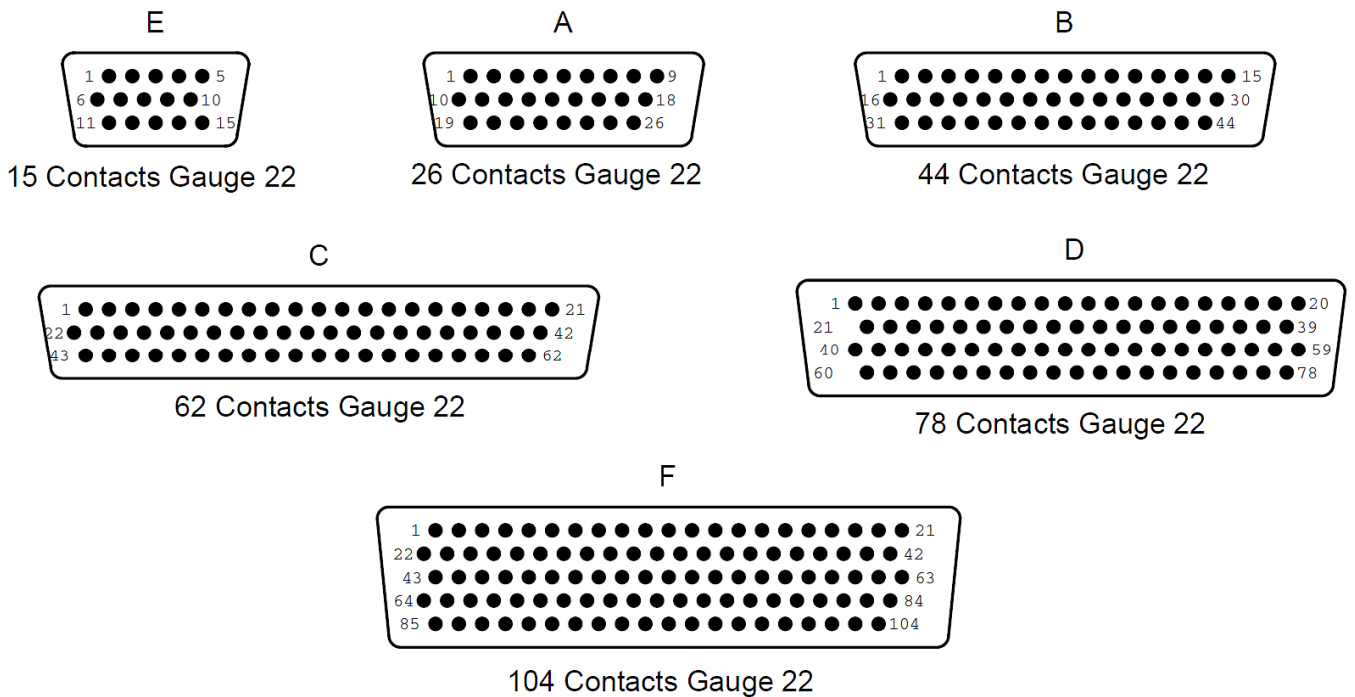

NOTES:

1. Contact locations are in conformity with MIL-DTL-24308 specification sheets and shall not be checked during procurement.
2. Both sides of the insert shall be marked with the minimum marking shown.

4 REQUIREMENTS

4.1 GENERAL

The complete requirements for procurement of the connectors specified herein are stated in this specification and ESCC Generic Specification No. 3401. Deviations from the Generic Specification, applicable to this specification only, are listed in Para. 4.2.

Deviations from the applicable Generic Specification and this Detail Specification, formally agreed with specific Manufacturers on the basis that the alternative requirements are equivalent to the ESCC requirements and do not affect the components' reliability, are listed in the appendices attached to this specification.

4.2 DEVIATIONS FROM GENERIC SPECIFICATION

4.2.1 Deviations from Special In-Process Controls

None.

4.2.2 Deviations from Final Production Tests (Chart II)

(a) Para. 9.1.1.4, Mated Shell Conductivity: Not applicable.

4.2.3 Deviations from Burn-in and Electrical Measurements (Chart III)

Chart III is not applicable.

4.2.4 Deviations from Qualification Tests (Chart IV)

- (a) Para. 9.1.1.4, Mated Shell Conductivity: Not applicable.
- (b) Para. 9.9, Seal Test: Not applicable.
- (c) Para. 9.10, Wiring: Not applicable.
- (d) Para. 9.24, Jackscrew Retention: Not applicable.

4.2.5 Deviations from Lot Acceptance Tests (Chart V)

- (a) Para. 9.1.1.4, Mated Shell Conductivity: Not applicable.
- (b) Para. 9.9, Seal Test: Not applicable.
- (c) Para. 9.10, Wiring: Not applicable.

4.3 MECHANICAL REQUIREMENTS

4.3.1 Dimension Check

The dimensions of the connector savers specified herein shall be verified in accordance with the requirements set out in Para. 9.6 of ESCC Generic Specification No. 3401 and shall conform to those shown in Figure 2 of this specification.

4.3.2 Weight

The maximum weight of the connector savers specified herein, without contacts, shall be as specified in Table 1(a).

4.3.3 Contact Capability

As specified in ESCC Detail Specification No. 3401/021.

4.3.4 Contact Retention (in Insert)

As specified in ESCC Detail Specification No. 3401/021.

4.3.5 Mating and Unmating Forces

The forces applied for the mating and unmating of the connector savers shall conform to the values specified in Table 1(a).

4.3.6 Insert Retention (in Shell)

Connector saver inserts shall withstand a pressure of 42.8N/cm^2 without being dislodged from the shell.

4.3.7 Jackscrew Retention

Not applicable.

4.3.8 Contact Insertion and Withdrawal Forces

As specified in ESCC Detail Specification No. 3401/021.

4.3.9 Engagement and Separation Forces

As specified in ESCC Detail Specification No. 3401/021.

4.3.10 Oversize Pin Exclusion

As specified in ESCC Detail Specification No. 3401/021.

4.3.11 Probe Damage

As specified in ESCC Detail Specification No. 3401/021.

4.3.12 Solderability

Not applicable.

4.4 MATERIALS AND FINISHES

The materials and finishes shall be as specified herein. Where a definite material is not specified, a material which will enable the components specified herein to meet the performance requirements of this specification shall be used. Acceptance or approval of any constituent material does not guarantee acceptance of the finished product.

4.4.1 Shells

Shells of shell sizes E, A, B, C and D shall be made of brass. The plating shall be $0.7\mu\text{m}$ minimum of gold over $1\mu\text{m}$ of copper.

Shells of shell size F shall be made of aluminium alloy. The plating shall be either $2.54\mu\text{m}$ of electroless nickel (Modification Code A174), or $0.7\mu\text{m}$ of gold with $25.4\mu\text{m}$ minimum electroless nickel underplating (Modification Code FR172).

4.4.2 Inserts

Inserts shall be made of glass-fibre filled diallylphthalate resin or a suitable thermoplastic material.

4.4.3 Spacers

Spacers shall be made of polyimide material.

4.4.4 Contacts

As specified in ESCC Detail Specification No. 3401/021.

4.4.5 Contact Retaining Clip

The retaining clip shall be made of beryllium copper.

4.4.6 Guiding and Locking Devices

As specified in ESCC Detail Specification Nos. 3401/022 and 3401/085.

4.4.7 Magnetism Level

The allowable value of magnetism shall not exceed that specified for the relevant level (see Para. 4.5.4.6)

4.5 MARKING

4.5.1 General

The marking of components delivered to this specification shall be in accordance with the requirements of ESCC Basic Specification No. 21700 and the following paragraphs. When the component is too small to accommodate all of the marking specified, as much as space permits shall be marked and the marking information, in full, shall accompany the component in its primary package.

Each component shall be marked in respect of:

- (a) Contact Identification.
- (b) The ESCC Component Number.
- (c) Characteristics.
- (d) Traceability Information.

4.5.2 Contact Identification

Contact identification shall be marked in accordance with Figure 2.

4.5.3 The ESCC Component Number

Each component shall bear the ESCC Component Number which shall be constituted and marked as follows:

Example: 340102001B

- Detail Specification Number: 3401020
- Type Variant (See Table 1(a)): 01
- Testing Level: B

4.5.4 Characteristics

The characteristics to be marked in the following order of precedence are:

- (a) Series.
- (b) Shell Size.
- (c) Insert Type.
- (d) Contact Arrangement.
- (e) Type of Contact.
- (f) Magnetism Level.
- (g) Modification Code.
- (h) Contact Information.

The information shall be constituted and marked as follows (example): DABMA15PSNMB FO

- Series: D
- Shell size: A
- Insert type: BMA
- Contact Arrangement: 15
- Type of Contact: PS
- Magnetism Level (200 gamma): NMB
- Modification Code: omitted
- Contact Information: FO (Savers ordered without contacts).

4.5.4.1 *Series*

This connector saver series shall be designated by the letter D.

4.5.4.2 *Shell Size*

Shell size shall be indicated by the code letters specified hereafter.

E	A	B	C	D	F (1)
---	---	---	---	---	-------

NOTES:

- 1. Variant 02 only.

4.5.4.3 *Insert Type*

The insert type with contacts is defined by the letters BMA.

4.5.4.4 *Contact Arrangements*

The number of contacts shall be as shown in Figure 2(b) and contact arrangements shall be indicated by the codes specified hereafter:

Shell Size	Code	
	Variant 01	Variant 02
E	9	15
A	15	26
B	25	44
C	37	62
D	50	78
F	-	104

4.5.4.5 Type of Contact

The contact types shall be indicated by the following code letters.

Code Letter	Contact Type
PS	Male/Female

4.5.4.6 Magnetism Level

The following codes shall be used for magnetism level:

Code	Definition
NMA	Magnetism Level: ≤ 2000 gamma
NMB	Magnetism Level: ≤ 200 gamma
NMC	Magnetism Level: ≤ 20 gamma
NMD	Magnetism Level: ≤ 2 gamma

4.5.4.7 Modification Code

The modification code for the finish of shell size F (aluminium alloy) shall be:

- A174 for the electroless nickel finish.
- FR172 for the gold over electroless nickel finish.

The modification code shall be omitted for shell sizes E, A, B, C and D.

4.5.4.8 Contact Information

FO = Connector ordered without contacts. This information shall only be marked on the packaging and not marked on the connector.

Contacts must be from the same Manufacturer as the connector in which they are mounted and this shall be verified prior to assembly.

4.5.5 Traceability Information

Traceability information shall be marked in accordance with the requirements of ESCC Basic Specification No. 21700.

4.6 ELECTRICAL MEASUREMENTS

4.6.1 Electrical Measurements at Room Temperature

The parameters to be measured in respect of electrical characteristics are scheduled in Table 2. Unless otherwise specified, the measurement shall be performed at $T_{amb} = +22 \pm 3$ °C.

4.6.2 Electrical Measurements at High and Low Temperatures (Table 3)

Not applicable.

4.6.3 Circuit for Electrical Measurements (Figure 4)

Not applicable.

4.7 BURN-IN AND ELECTRICAL MEASUREMENTS (TABLES 4 AND 5)

Not applicable.

TABLE 2 - ELECTRICAL MEASUREMENTS AT ROOM TEMPERATURE

No.	Characteristic	Symbol	ESCC 3401 Test Method	Test Condition	Limits		Unit
					Min	Max	
1	Insulation Resistance	R_i	Para. 9.1.1.1	Para. 9.1.1.1	5000	-	M Ω
2	Voltage Proof Leakage Current Variant 01 Variant 02	I_L	Para. 9.1.1.2	1250Vrms 1000Vrms	- -	2 2	mA mA
3	Mated Shell Conductivity (Voltage Drop) Note 1	V_d	Para. 9.1.1.4	Para. 9.1.1.4	Not applicable		mV

NOTES:

1. Applicable to mated connectors with grounding option.

TABLES 3, 4 AND 5

Not applicable.

- 4.8 ENVIRONMENTAL AND ENDURANCE TESTS (CHARTS IV AND V OF ESCC GENERIC SPECIFICATION NO. 3401)
- 4.8.1 Measurements and Inspections on Completion of Environmental Tests
The parameters to be measured and inspections to be performed on completion of environmental testing shall be those specified in Table 6. Unless otherwise specified, these measurements shall be performed at $T_{amb} = +22 \pm 3$ °C.
- 4.8.2 Measurements and Inspections at Intermediate Points during Endurance Tests
Not applicable.
- 4.8.3 Measurements and Inspections on Completion of Endurance Tests
The parameters to be measured and inspections to be performed on completion of endurance testing shall be those specified in Table 6. Unless otherwise specified, the measurements shall be performed at $T_{amb} = +22 \pm 3$ °C.
- 4.8.4 Conditions for Operating Life Test (Part of Endurance Testing)
Not applicable.
- 4.8.5 Electrical Circuit for Operating Life Test (Figure 5)
Not applicable.
- 4.8.6 Conditions for High Temperature Storage Test (Part of Endurance Testing)
The requirements for the high temperature storage test are specified in Section 9 of ESCC Generic Specification No. 3401. The temperature to be applied shall be the maximum storage temperature specified in Table 1(b) of this specification.

TABLE 6 - MEASUREMENTS AND INSPECTIONS ON COMPLETION OF ENVIRONMENTAL AND ENDURANCE TESTING

No.	ESCC Generic Spec. No. 3401		Measurements and Inspections		Symbol	Limits		Unit	
	Environmental and Endurance Tests Note 1	Test Method and Conditions	Identification	Conditions		Min	Max		
01	Seal Test	Para. 9.9	ESCC 3401 Para. 9.9	-	-	Not applicable		-	
02	Wiring	Para. 9.10	Not applicable	-	-	-	-		
03	Vibration	Para. 9.11	Initial Measurements						
			Coupling screw(s) Unlocking Torque	-	-	Not applicable		-	
			Final Measurements Full Engagement						
			Coupling screw(s) Unlocking Torque Drift	-	Δ	Not applicable		-	
			Visual Examination	-	-	-	-	-	
04	Shock or Bump	Para. 9.12	Full Engagement Visual Examination	-	-	-	-	-	
05	Climatic Sequence	Para. 9.13	Dry Heat						
			Insulation Resistance	Table 2, Item 1	R _i	1000	-	MΩ	
			Low Air Pressure						
			Voltage Proof Leakage Current	Figure 1	I _L	Table 2 Item 2		mA	
			Damp Heat						
			Insulation Resistance	Immediately after test Table 2, Item 1	R _i	100	-	MΩ	
			Final Measurements	After 1-24 hrs Recovery					
External Visual Inspection	ESCC 3401 Para. 9.7	-	ESCC 3401 Para. 9.7		-				
Insulation Resistance	Table 2, Item 2	R _i	Table 2, Item 1		MΩ				
Voltage Proof Leakage Current	Table 2, Item 2	I _L	Table 2, Item 2		mA				
06	Plating Thickness	Para. 9.14	Thickness	-	-	ESCC 3401/021		-	
07	Joint Strength	Para. 9.15	ESCC 3401 Para. 9.15	-	-	ESCC 3401 Para. 9.15		-	

No.	ESCC Generic Spec. No. 3401		Measurements and Inspections		Symbol	Limits		Unit
	Environmental and Endurance Tests Note 1	Test Method and Conditions	Identification	Conditions		Min	Max	
08	Rapid Change of Temperature	Para. 9.16	Visual Examination Insulation Resistance Voltage Proof Leakage Current	- Table 2, Item 1 Table 2, Item 2	- R _i I _L	- Table 2, Item 1 Table 2, Item 2	- - -	- MΩ mA
09	Contact Retention (in Insert)	Para. 9.17 & Para. 4.3.4 of this spec.	Contact Displacement	-	-	ESCC 3401 Para. 9.17	-	-
10	Endurance	Para. 9.18	Initial Measurements Mating/Unmating Forces Low Level Contact Resistance Mated Shell Conductivity Final Measurements Visual Examination Mating/Unmating Forces Low Level Contact Resistance Drift Mated Shell Conductivity Insulation Resistance Voltage Proof Leakage Current	- ESCC 3401/021 Table 2, Item 3 - - - - ESCC 3401/021 Table 2, Item 3 Table 2, Item 1 Table 2, Item 2	F R _{cd} V _d - F ΔR _{cd} V _d R _i I _L	Para. 4.3.5 of this spec. Record Values Not applicable - Para. 4.3.5 of this spec. ESCC 3401/021 Not applicable Table 2, Item 1 Table 2, Item 2	- - - - - - - - - - -	N mΩ mV - N mΩ mV MΩ mA
11	Permanence of Marking	Para. 9.19	As applicable	-	-	-	-	-
12	Mating/Unmating Forces	Para. 9.20	Force	-	F	Para. 4.3.5 of this spec.	-	N

No.	ESCC Generic Spec. No. 3401		Measurements and Inspections		Symbol	Limits		Unit
	Environmental and Endurance Tests Note 1	Test Method and Conditions	Identification	Conditions		Min	Max	
13	High Temperature Storage	Para. 9.21	Initial Measurements					
			Low Level Contact Resistance	ESCC 3401/021	R_{cl}	Record Values		mΩ
			Mated Shell Conductivity	Table 2, Item 3	V_d	Not applicable		mV
			Final Measurements					
			Visual Examination	-	-	-	-	-
			Mating/Unmating Forces	-	F	Para. 4.3.5 of this spec.		N
			Low Level Contact Resistance Drift	ESCC 3401/021	ΔR_{cl}	ESCC 3401/021		mΩ
			Rated Current Contact Resistance	ESCC 3401/021	R_{cr}	ESCC 3401/021		mΩ
			Mated Shell Conductivity	Table 2, Item 3	V_d	Not applicable		mΩ
			Insulation Resistance	Table 2, Item 1	R_i	Table 2, Item 1		MΩ
Voltage Proof Leakage Current	Table 2, Item 2	I_L	Table 2, Item 2		mA			
Contact Retention (in Insert)	Para. 4.3.4 of this spec.	-	ESCC 3401 Para. 9.17		N			
14	Corrosion	Para. 9.22	Visual Examination	-	-	-	-	-
15	Insert Retention (in Shell)	Para. 9.23 & Para. 4.3.6 of this spec.	Visual Examination	-	-	Para. 4.3.6 of this spec.		-
16	Jackscrew Retention	Para. 9.24 & Para. 4.3.7 of this spec	Visual Examination	-	-	Not applicable		-
17	High Temperature Measurements	Para. 9.25	Insulation Resistance	Table 2 Item 1	R_i	500	-	MΩ
18	Overload Test	Para. 9.26	Internal Temperature	-	T	-	+100	°C
			Rated Current Contact Resistance	ESCC 3401/021	R_{cr}	ESCC 3401/021		mΩ
			Mated Shell Conductivity	Table 2 Item 3	V_d	Not applicable		mV
			Insulation Resistance	Table 2 Item 1	R_i	Table 2, Item 1		MΩ
			Voltage Proof Leakage	Table 2 Item 2	I_L	Table 2, Item 2		mA

No.	ESCC Generic Spec. No. 3401		Measurements and Inspections		Symbol	Limits		Unit
	Environmental and Endurance Tests Note 1	Test Method and Conditions	Identification	Conditions		Min	Max	
			Current					
19	Maintenance Aging	Para. 9.27	Visual Examination	-	-	-	-	-
			Contact Retention (in Insert)	Para. 4.3.4 of this spec.	-	ESCC 3401 Para. 9.17		N
			Contact insertion and withdrawal forces	Para. 4.3.8 of this spec.	F	Para. 4.3.8 of this spec.		N
20	Engage/Separation Forces	Para. 9.28 & Para. 4.3.9 of this spec.	Force	-	F	Para. 4.3.9 of this spec.		N
21	Oversize Pin Exclusion	Para. 9.29 & Para. 4.3.10 of this spec.	-	-	-	ESCC 3401 Para. 9.29		-
22	Probe Damage	Para. 9.30 & Para. 4.3.11 of this spec.	Contact Separation Force	Para. 4.3.9 of this spec.	-	Para. 4.3.9 of this spec.		-
23	Solderability	Para. 9.31 & Para. 4.3.12 of this spec.	-	-	-	Para. 4.3.12 of this spec.		-

NOTES:

1. The tests in this Table refer to either Chart IV or V and shall be used as applicable.

APPENDIX 'A'
AGREED DEVIATIONS FOR C&K COMPONENTS (F)

ITEMS AFFECTED	DESCRIPTION OF DEVIATIONS
Para. 4.2.2	Para. 9.3, Contact Retainer Test may be omitted provided that a 100% external visual inspection of the contact retainer clips positioned within the insert is performed in accordance with the C&K COMPONENTS PID requirements.

APPENDIX 'B'
AGREED DEVIATIONS FOR SOURIAU (F)

ITEMS AFFECTED	DESCRIPTION OF DEVIATIONS
Para. 4.2.2	Para. 9.3, Contact Retainer Test may be omitted provided that a 100% external visual inspection of the contact retainer clips positioned within the insert is performed in accordance with the SOURIAU PID requirements.