



**ACCESSORIES FOR CONNECTORS,
MICROMINIATURE 3401/029, 3401/077 AND
CONNECTOR SAVERS 3401/041**

ESCC Detail Specification No. 3401/032

Issue 11	April 2019
----------	------------



Document Custodian: European Space Agency – see <https://escies.org>

LEGAL DISCLAIMER AND COPYRIGHT

European Space Agency, Copyright © 2019. All rights reserved.

The European Space Agency disclaims any liability or responsibility, to any person or entity, with respect to any loss or damage caused, or alleged to be caused, directly or indirectly by the use and application of this ESCC publication.

This publication, without the prior permission of the European Space Agency and provided that it is not used for a commercial purpose, may be:

- copied in whole, in any medium, without alteration or modification.
- copied in part, in any medium, provided that the ESCC document identification, comprising the ESCC symbol, document number and document issue, is removed.

DOCUMENTATION CHANGE NOTICE

(Refer to <https://escies.org> for ESCC DCR content)

DCR No.	CHANGE DESCRIPTION
1240	Specification upissued to include changes per DCR.

TABLE OF CONTENTS

1	GENERAL	5
1.1	SCOPE	5
1.2	COMPONENT TYPE VARIANTS	5
1.3	MAXIMUM RATINGS	5
1.4	PARAMETER DERATING INFORMATION	5
1.5	PHYSICAL DIMENSIONS	5
1.6	FUNCTIONAL DIAGRAM	5
2	APPLICABLE DOCUMENTS	19
3	TERMS, DEFINITIONS, ABBREVIATIONS, SYMBOLS AND UNITS	25
4	REQUIREMENTS	26
4.1	GENERAL	26
4.2	DEVIATIONS FROM GENERIC SPECIFICATION	26
4.2.1	Deviations from Special In-process Controls	26
4.2.2	Deviations from Final Production Tests (Chart II)	26
4.2.3	Deviations from Burn-in and Electrical Measurements (Chart III)	26
4.2.4	Deviations from Qualification, Environmental and Endurance Tests (Chart IV)	26
4.2.5	Deviations from Lot Acceptance Tests (Chart V)	26
4.3	MECHANICAL REQUIREMENTS	26
4.3.1	Dimension Check	26
4.3.2	Weight	26
4.3.3	Torque Value	26
4.4	MATERIALS AND FINISHES	26
4.4.1	Screw Lock Assemblies and Brackets	27
4.4.2	Interfacial Seals	27
4.5	MARKING	27
4.5.1	General	27
4.5.2	The ESCC Component Number	27
4.5.3	Traceability Information	27
4.6	ELECTRICAL MEASUREMENTS	27
4.7	SCREENING TESTS (TABLES 4 AND 5)	27
4.8	ENVIRONMENTAL AND ENDURANCE TESTS	27

1 GENERAL

1.1 SCOPE

This specification details the ratings, physical and electrical characteristics, test and inspection data of Accessories for Microminiature Connectors [3401/029](#) (Type MDM), Connector Savers [3401/041](#) and Microminiature Connectors with Removable Contacts [3401/077](#) (Type MDMA).

It shall be read in conjunction with:

- ESCC Generic Specification No. [3401](#), Connectors, Electrical, Circular and Rectangular.
- ESCC Detail Specification No. [3401/029](#), Connectors, Electrical, Rectangular, Microminiature, based on Type MDM.
- ESCC Detail Specification No. [3401/041](#), Connector Savers, Electrical, Rectangular, Microminiature, based on type MDM.
- ESCC Detail Specification No. [3401/077](#), Connectors, Electrical, Rectangular, Microminiature, Removable Contacts, based on type MDMA.
- ESCC Detail Specification No. [3401/087](#), Lightweight Accessories for Rectangular, Microminiature Connectors, [3401/029](#) and [3401/077](#)

the requirements of which are supplemented herein.

1.2 COMPONENT TYPE VARIANTS

The type variants of accessories covered by this specification are given in Table 1(a).

1.3 MAXIMUM RATINGS

The maximum ratings, which shall not be exceeded at any time during use or storage, applicable to the accessories specified herein, are as scheduled in Table 1(b).

1.4 PARAMETER DERATING INFORMATION

Not applicable.

1.5 PHYSICAL DIMENSIONS

The physical dimensions of the accessories specified herein are shown in Figure 2.

1.6 FUNCTIONAL DIAGRAM

Not applicable.

TABLE 1(a) – TYPE VARIANTS

Variant	Description (1)	For Use With
03	90° Mounting Bracket, Shell Sizes 9 to 37	ESCC 3401/029 Variants 01, 02 ESCC 3401/077 Variants 01, 02
04	90° Mounting Bracket, Shell Size 51	ESCC 3401/029 Variants 01, 02
07	Screw Sub-Assembly	ESCC 3401/029 Variants 01, 02 ESCC 3401/077 Variants 01, 02
08	Screwlock Sub-Assembly (Front Panel Mounting) with Nut and Lock-Washer	ESCC 3401/029 Variants 01, 02 ESCC 3401/077 Variants 01, 02
09	Screwlock Sub-Assembly (Rear Panel Mounting) with Nut and Lock-Washer – Panel Thickness 1.6mm	ESCC 3401/029 Variants 01, 02 ESCC 3401/077 Variants 01, 02
10	Screwlock Assembly for Connector Savers	ESCC 3401/041 Variants 01 to 07
11	Screwlock for Connectors FR136/FR139	ESCC 3401/029 Variants 01, 02
12	Interfacial Seals for MDMA Female Connectors, Shell Size 9	ESCC 3401/077 Variants 01, 02
13	Interfacial Seals for MDMA Female Connectors, Shell Size 15	ESCC 3401/077 Variants 01, 02
14	Interfacial Seals for MDMA Female Connectors, Shell Size 21	ESCC 3401/077 Variants 01, 02
15	Interfacial Seals for MDMA Female Connectors, Shell Size 25	ESCC 3401/077 Variants 01, 02
16	Interfacial Seals for MDMA Female Connectors, Shell Size 31	ESCC 3401/077 Variants 01, 02
17	Interfacial Seals for MDMA Female Connectors, Shell Size 37	ESCC 3401/077 Variants 01, 02
18	Screw Sub-Assembly for Lightweight Backshell	ESCC 3401/077 Variants 01 to 56
19	Interfacial Seals for MDMA Female Connectors, Shell Size 51	ESCC 3401/077 Variants 01, 02
20	Screwlock Sub-Assembly (Front Panel Mounting) with Self-Locking Nut	ESCC 3401/029 Variants 01, 02 ESCC 3401/077 Variants 01, 02
21	Screwlock Sub-Assembly (Rear Panel Mounting) with Self-Locking Nut	ESCC 3401/029 Variants 01, 02 ESCC 3401/077 Variants 01, 02
22	Screw Sub-Assembly, Hex. Hole Head	ESCC 3401/029 Variants 01, 02 ESCC 3401/077 Variants 01, 02
23	Screwlock Sub-Assembly (Rear Panel Mounting) with Nut and Lock-Washer – Panel Thickness 0.8mm	ESCC 3401/029 Variants 01, 02 ESCC 3401/077 Variants 01, 02
24	Screwlock Sub-Assembly (Rear Panel Mounting) with Nut and Lock-Washer – Panel Thickness 1.2mm	ESCC 3401/029 Variants 01, 02 ESCC 3401/077 Variants 01, 02
25	Screwlock Sub-Assembly (Rear Panel Mounting) with Nut and Lock-Washer – Panel Thickness 2mm	ESCC 3401/029 Variants 01, 02 ESCC 3401/077 Variants 01, 02
26	Screwlock Sub-Assembly (Rear Panel Mounting) with Nut and Lock-Washer – Panel Thickness 2.4mm	ESCC 3401/029 Variants 01, 02 ESCC 3401/077 Variants 01, 02
27	Screwlock for Connectors 75SB	ESCC 3401/029 Variants 01, 02
28	Screwlock for Connectors 75SB (Rear Panel Mounting) with Nut and Lock-Washer – Panel Thickness 0.8mm	ESCC 3401/029 Variants 01, 02
29	Screwlock for Connectors 75SB (Rear Panel Mounting) with Nut and Lock-Washer – Panel Thickness 1.2mm	ESCC 3401/029 Variants 01, 02
30	Screwlock for Connectors 75SB (Rear Panel Mounting) with Nut and Lock-Washer – Panel Thickness 1.6mm	ESCC 3401/029 Variants 01, 02

Variant	Description (1)	For Use With
31	Screwlock for Connectors 75SB (Rear Panel Mounting) with Nut and Lock-Washer – Panel Thickness 2mm	ESCC 3401/029 Variants 01, 02
32	Screwlock for Connectors 75SB (Rear Panel Mounting) with Nut and Lock-Washer – Panel Thickness 2.4mm	ESCC 3401/029 Variants 01, 02
33	Screwlock for Connectors CBR/75RB	ESCC 3401/029 Variants 01, 02
34	Screwlock for Connectors CBR/75RB (Rear Panel Mounting) with Nut and Lock-Washer – Panel Thickness 0.8mm	ESCC 3401/029 Variants 01, 02
35	Screwlock for Connectors CBR/75RB (Rear Panel Mounting) with Nut and Lock-Washer – Panel Thickness 1.2mm	ESCC 3401/029 Variants 01, 02
36	Screwlock for Connectors CBR/75RB (Rear Panel Mounting) with Nut and Lock-Washer – Panel Thickness 1.6mm	ESCC 3401/029 Variants 01, 02
37	Screwlock for Connectors CBR/75RB (Rear Panel Mounting) with Nut and Lock-Washer – Panel Thickness 2mm	ESCC 3401/029 Variants 01, 02
38	Screwlock for Connectors CBR/75RB (Rear Panel Mounting) with Nut and Lock-Washer – Panel Thickness 2.4mm	ESCC 3401/029 Variants 01, 02

NOTES:

1. See Figure 2 for details.

TABLE 1(b) - MAXIMUM RATINGS

No.	Characteristics	Symbol	Maximum Ratings	Unit
1	Operating Temperature Range	T _{op}	-55 to +125	°C
2	Storage Temperature Range	T _{stg}	-55 to +125	°C
3	Torque Value	T	See Figure 2	Nm

FIGURE 1

Not applicable.

FIGURE 2 - PHYSICAL DIMENSIONS
VARIANTS 03 AND 04 - 90° MOUNTING BRACKET

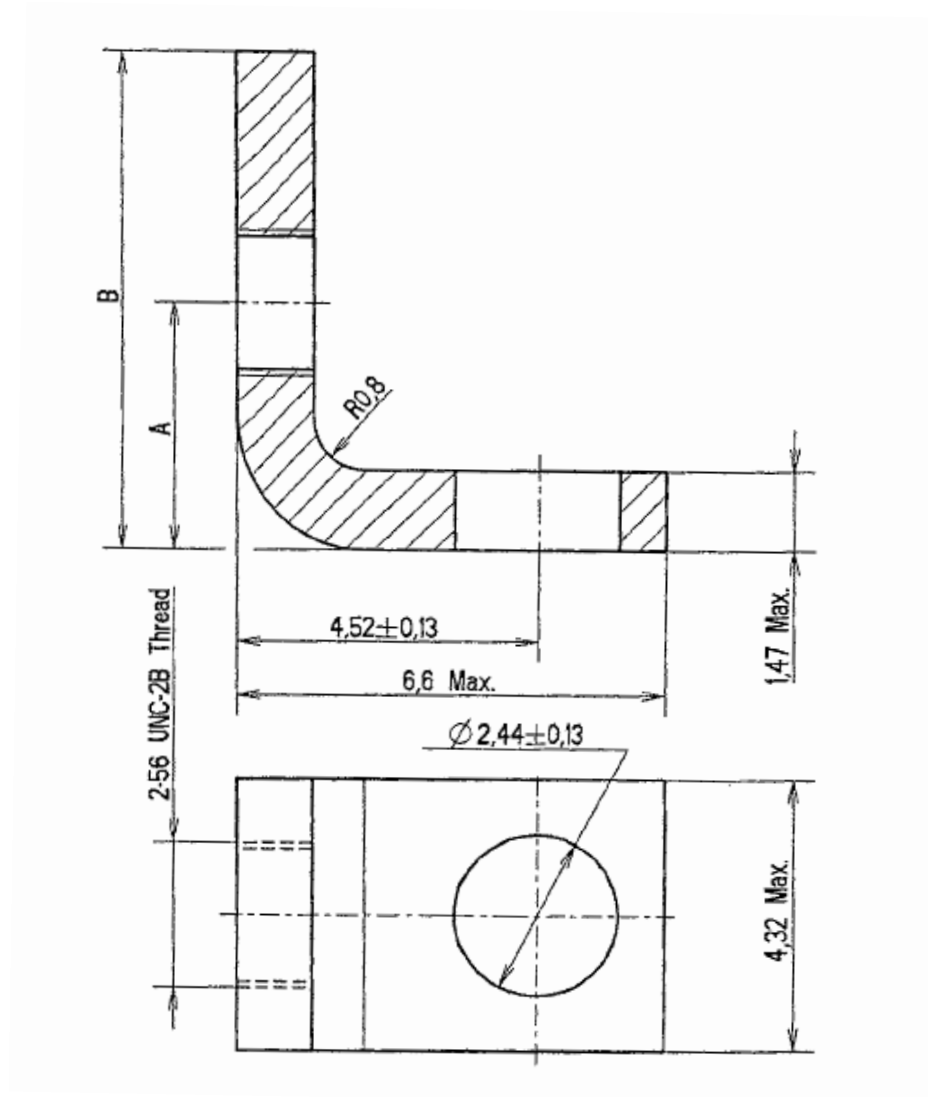

Variant	Sizes	A ± 0.13	B Max
03	9 to 37	3.73	7.82
04	51	4.29	8.89

NOTES:

1. All dimensions in mm.
2. Weight:
 - Variant 03 0.42g
 - Variant 04 0.45g
3. Variant 04 is not applicable to MDMA connectors.

VARIANT 07 - SCREW SUB-ASSEMBLY

Screw

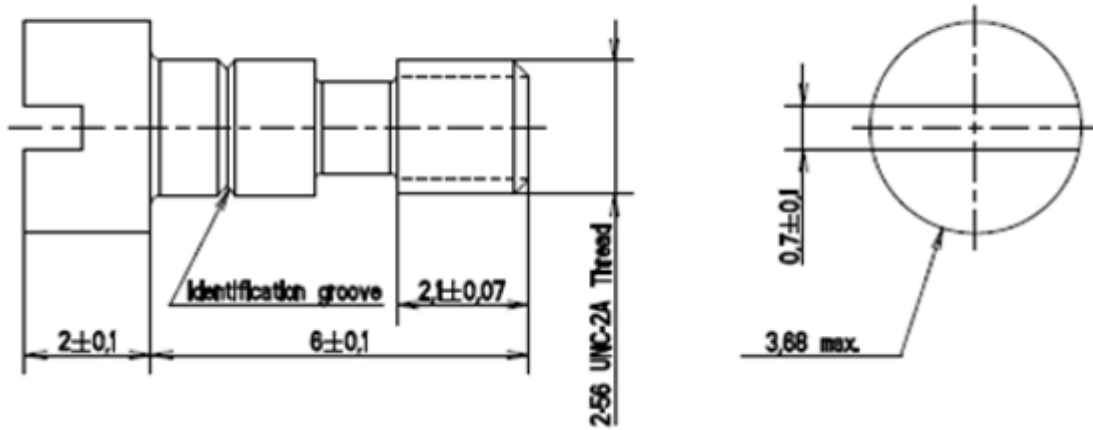

Clip

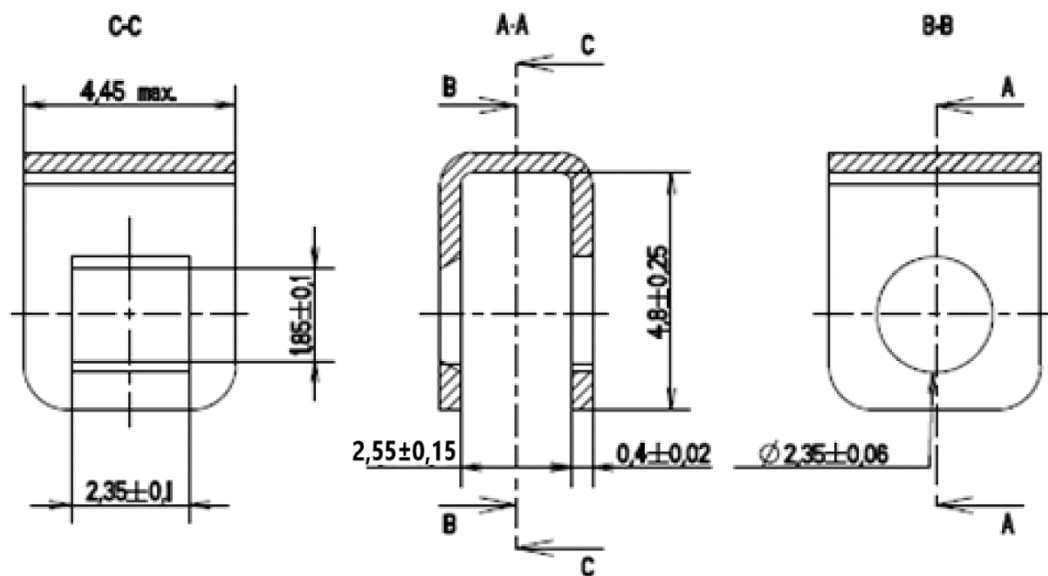

NOTES:

1. All dimensions in mm.
2. Weight:
 - Screw 0.3g
 - Clip 0.14g
- 3.

Torque Values	Min (Nm)	Max (Nm)
Screw	0.28	0.32

VARIANT 08 - SCREWLOCK SUB-ASSEMBLY (FRONT PANEL MOUNTING) WITH NUT AND LOCK-WASHER

Screwlock

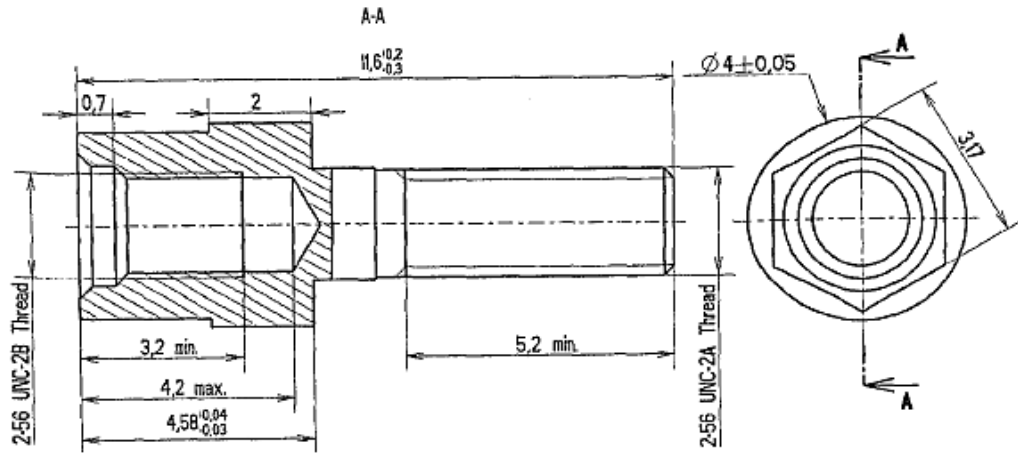

Nut

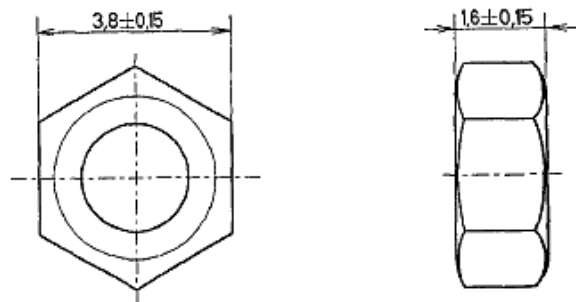

Lock-Washer

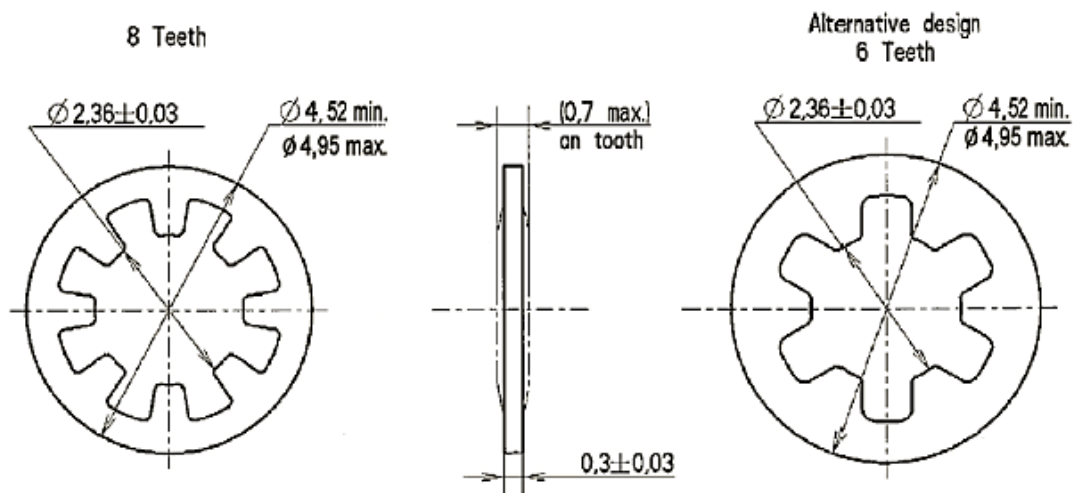

NOTES:

1. All dimensions in mm.
2. Weight:
 - Screwlock 0.51g
 - Nut 0.13g
 - Lock-Washer 0.02g
- 3.

Torque Values	Min (Nm)	Max (Nm)
Screwlock male side	0.44	0.48
Screwlock female side	0.28	0.32
Nut	0.44	0.48

VARIANT 09 - SCREWLOCK SUB-ASSEMBLY (REAR PANEL MOUNTING) WITH NUT AND LOCK-WASHER

Screwlock

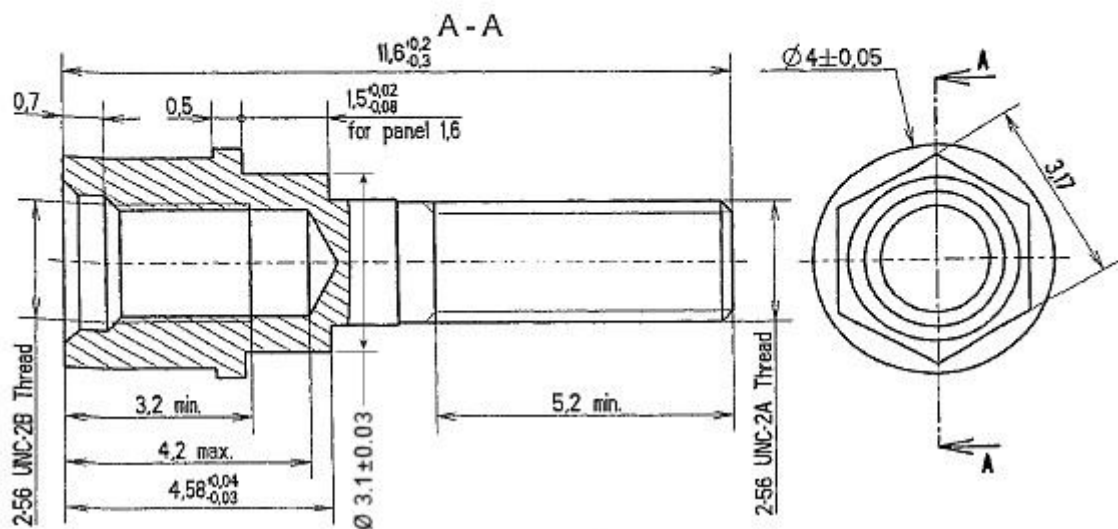

Nut

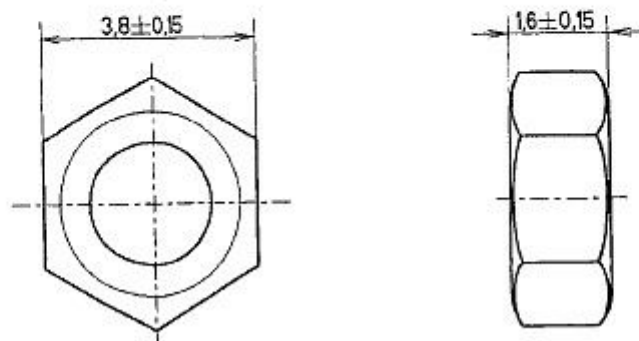

Lock-Washer

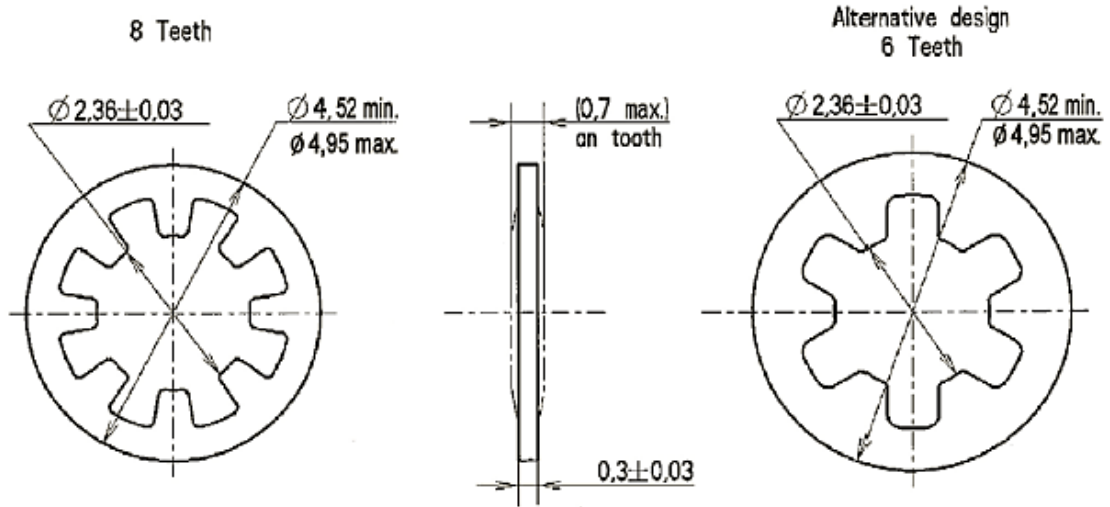

NOTES:

1. All dimensions in mm.
2. Weight:
 - Screwlock 0.45g
 - Nut 0.13g
 - Lock-Washer 0.02g
- 3.

Torque Values	Min (Nm)	Max (Nm)
Screwlock male side	0.44	0.48
Screwlock female side	0.28	0.32
Nut	0.44	0.48

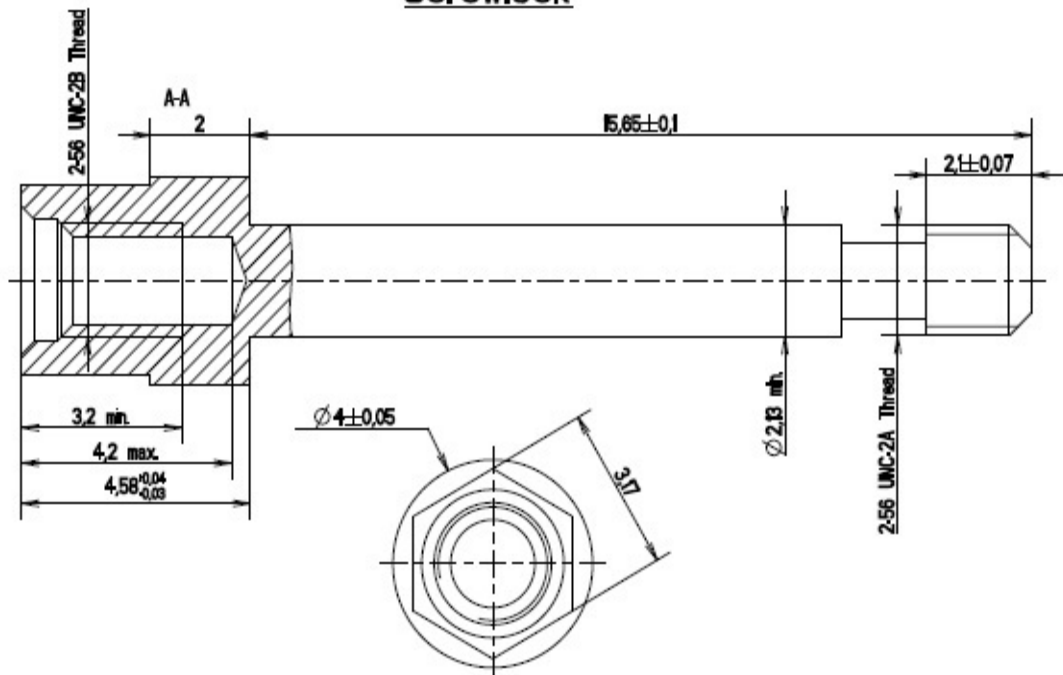
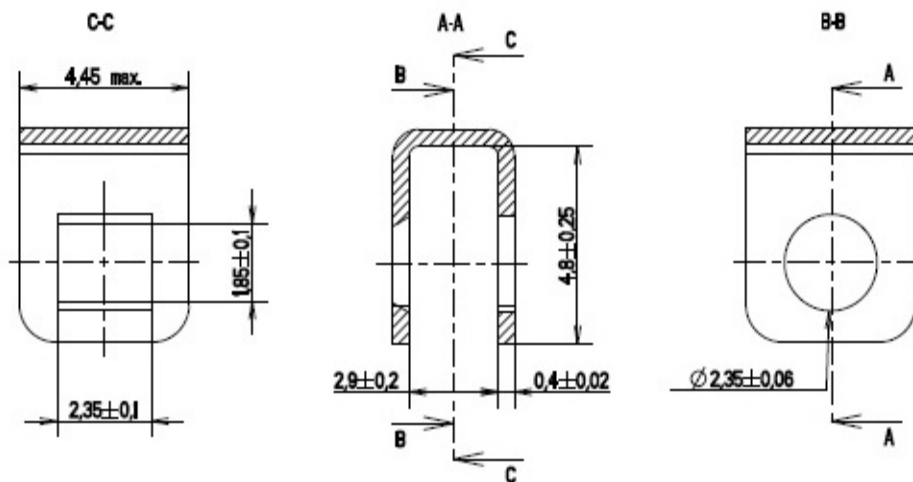
VARIANT 10 - SCREWLOCK ASSEMBLY FOR CONNECTOR SAVERS
Screwlock

Clip

NOTES:

1. All dimensions in mm.
2. Weight:
 - Screwlock 0.79g
 - Clip 0.14g
- 3.

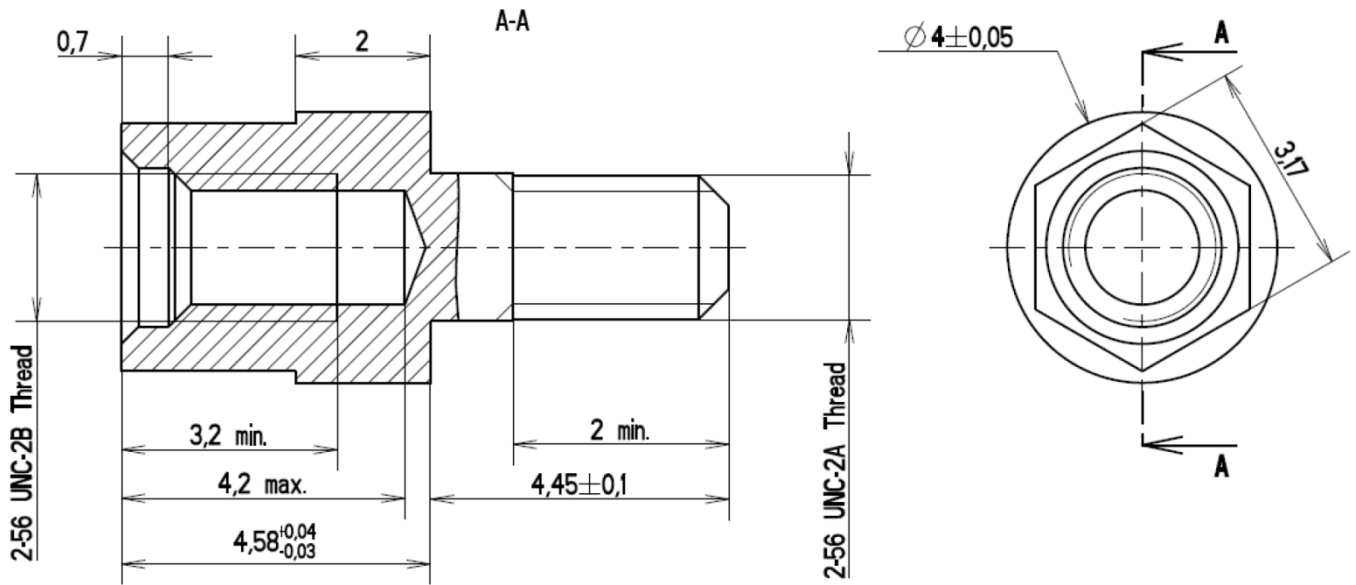
Torque Values	Min (Nm)	Max (Nm)
Screwlock male side	0.36	0.4
Screwlock female side	0.28	0.32

VARIANT 11 - SCREWLOCK FOR CONNECTORS FR136/FR139



NOTES:

1. All dimensions in mm.
2. Weight:
 - Screwlock 0.43g
- 3.

Torque Values	Min (Nm)	Max (Nm)
Screwlock male side	0.44	0.48
Screwlock female side	0.28	0.32

VARIANTS 12 TO 17 AND 19 - INTERFACIAL SEALS FOR MDMA FEMALE CONNECTORS

Variant 15 (shell size 25) shown for illustrative purposes

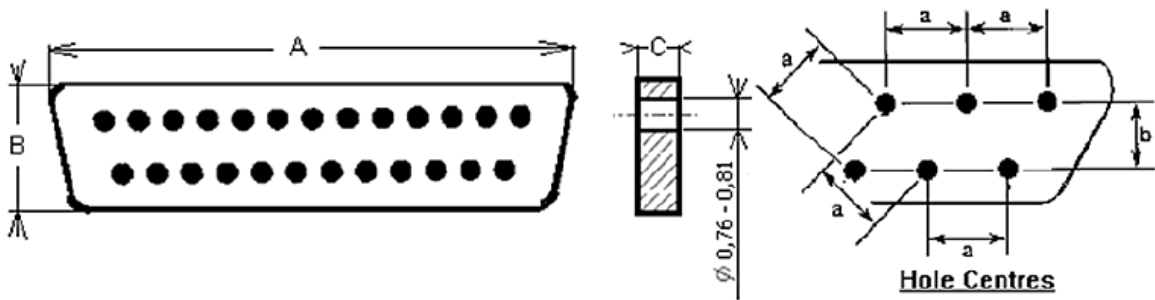

Variant	Shell Size	Dimensions (mm)						Weight Max. (g)
		A		B		C		
		Min	Max	Min	Max	Min	Max	
12	9	8.33	8.73	4.6	4.8	0.6	0.7	0.02
13	15	12.14	12.54	4.6	4.8	0.6	0.7	0.03
14	21	15.95	16.35	4.6	4.8	0.6	0.7	0.04
15	25	18.49	18.89	4.6	4.8	0.6	0.7	0.05
16	31	22.3	22.7	4.6	4.8	0.6	0.7	0.07
17	37	26.11	26.51	4.6	4.8	0.6	0.7	0.08
19	51	24.84	25.24	5.7	5.9	0.6	0.7	0.09

NOTES:

1. a = Distance between hole centres: 1.27mm typical.
2. b = Distance between rows: 1.09mm typical.

VARIANT 18 – SCREW SUB-ASSEMBLY FOR LIGHTWEIGHT BACKSHELL

Screw

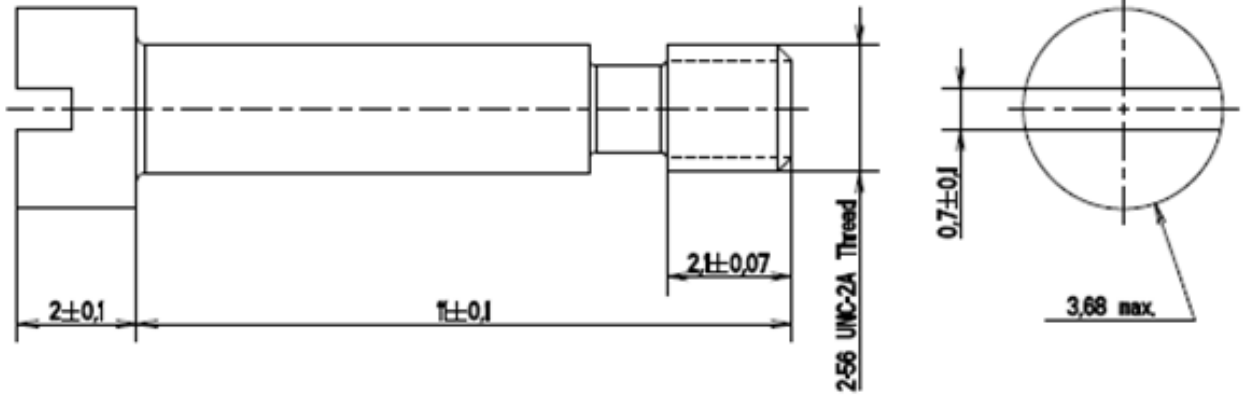

Clip

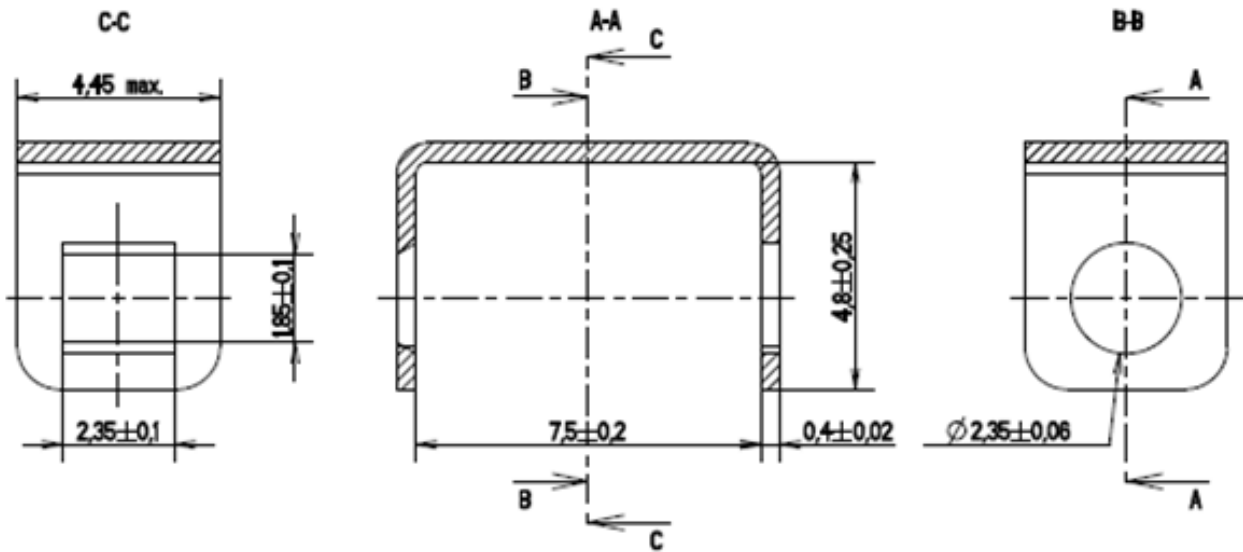

NOTES:

1. All dimensions in mm.
2. Weight:
 - Screw 0.6g
 - Clip 0.2g
- 3.

Torque Values	Min (Nm)	Max (Nm)
Screw	0.28	0.32

VARIANT 20 - SCREWLOCK SUB-ASSEMBLY (FRONT PANEL MOUNTING) WITH SELF-LOCKING NUT

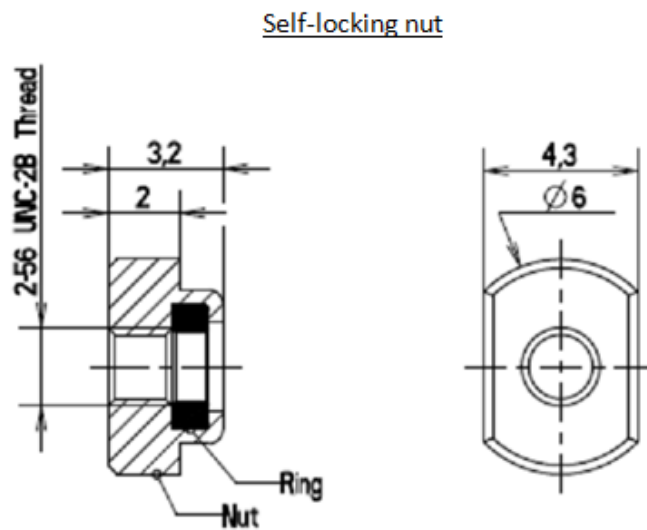
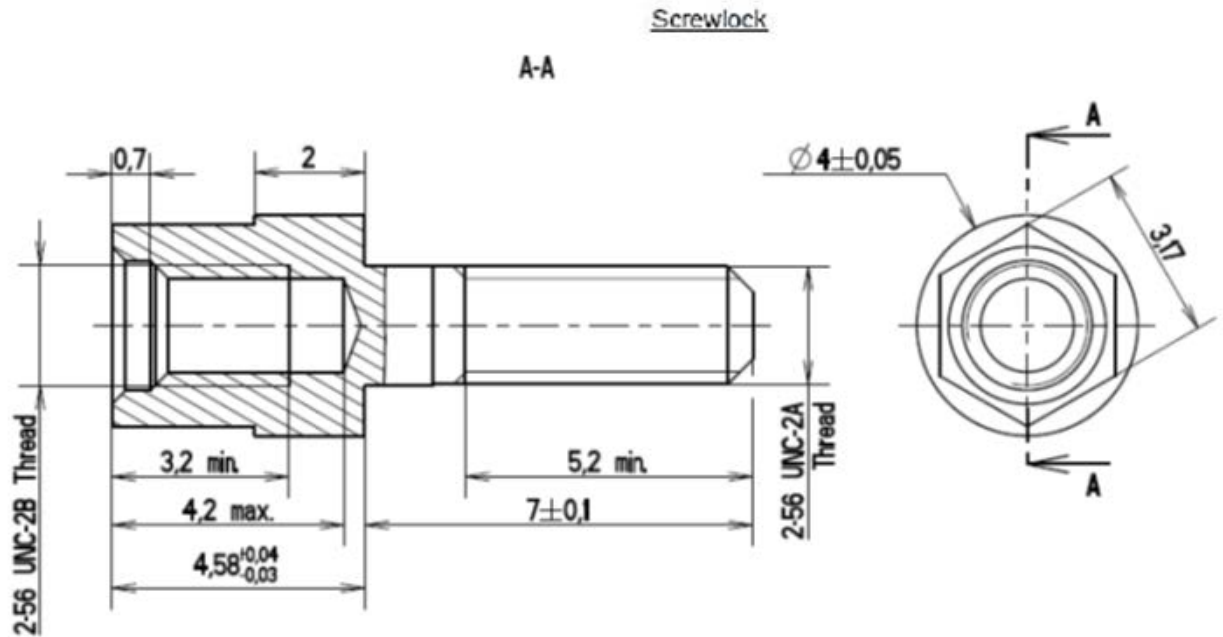

NOTES:

1. All dimensions in mm.
2. Weight:
 - Screwlock 0.51g
 - Self-locking Nut 0.4 g
- 3.

Torque Values	Min (Nm)	Max (Nm)
Screwlock male side	0.44	0.48
Screwlock female side	0.28	0.32
Self-locking Nut	0.44	0.48

VARIANT 21 - SCREWLOCK SUB-ASSEMBLY (REAR PANEL MOUNTING) WITH SELF-LOCKING NUT

Screwlock

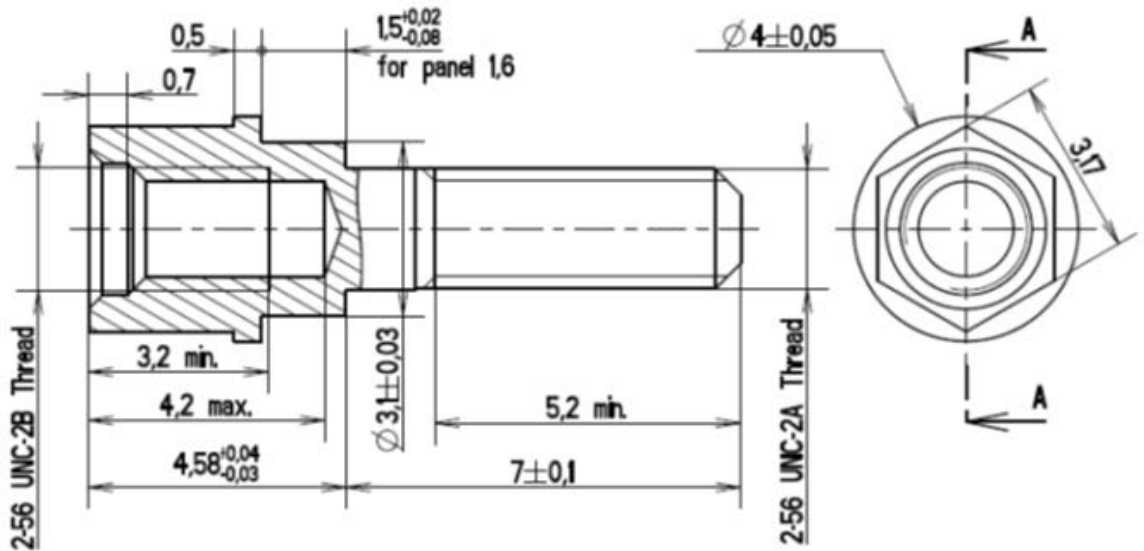

Self-locking nut

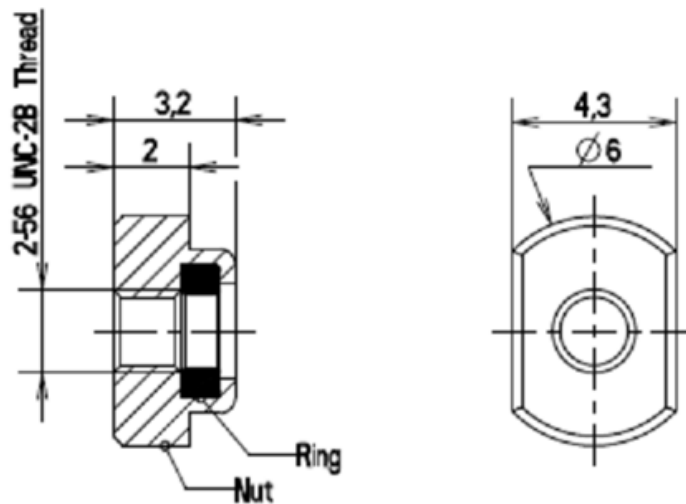

NOTES:

1. All dimensions in mm.
2. Weight:
 - Screwlock 0.45g
 - Self-Locking Nut 0.4 g
- 3.

Torque Values	Min (Nm)	Max (Nm)
Screwlock male side	0.44	0.48
Screwlock female side	0.28	0.32
Self-locking Nut	0.44	0.48

VARIANT 22 – SCREW SUB-ASSEMBLY, HEX. HOLE HEAD

Screw

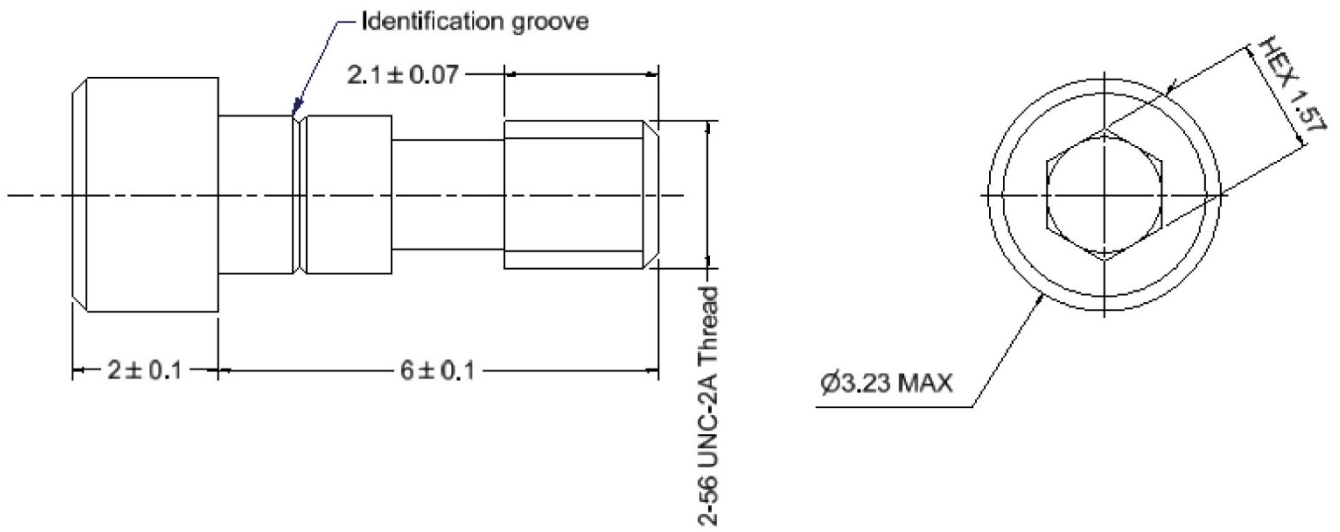

Clip

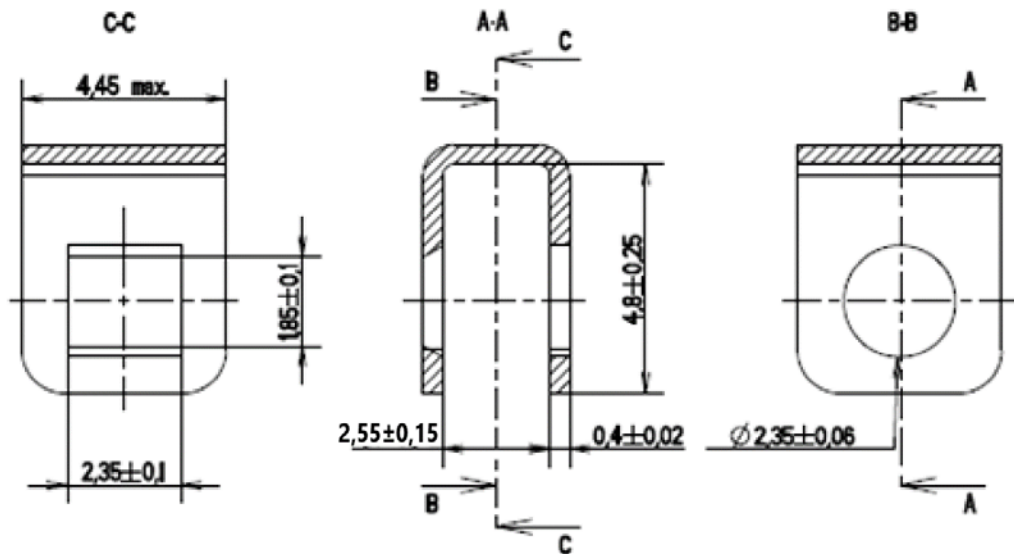

NOTES:

1. All dimensions in mm.
2. Weight:
 - Screw 0.3g
 - Clip 0.14g
- 3.

Torque Values	Min (Nm)	Max (Nm)
Screw	0.28	0.32

VARIANTS 23 TO 26 - SCREWLOCK SUB-ASSEMBLY (REAR PANEL MOUNTING) WITH NUT AND LOCK-WASHER

Screwlock

Variant	23	24	25	26
Panel Thickness (+0.2 -0)	0.8	1.2	2	2.4
Dimension A	0.7	1.1	1.9	2.3

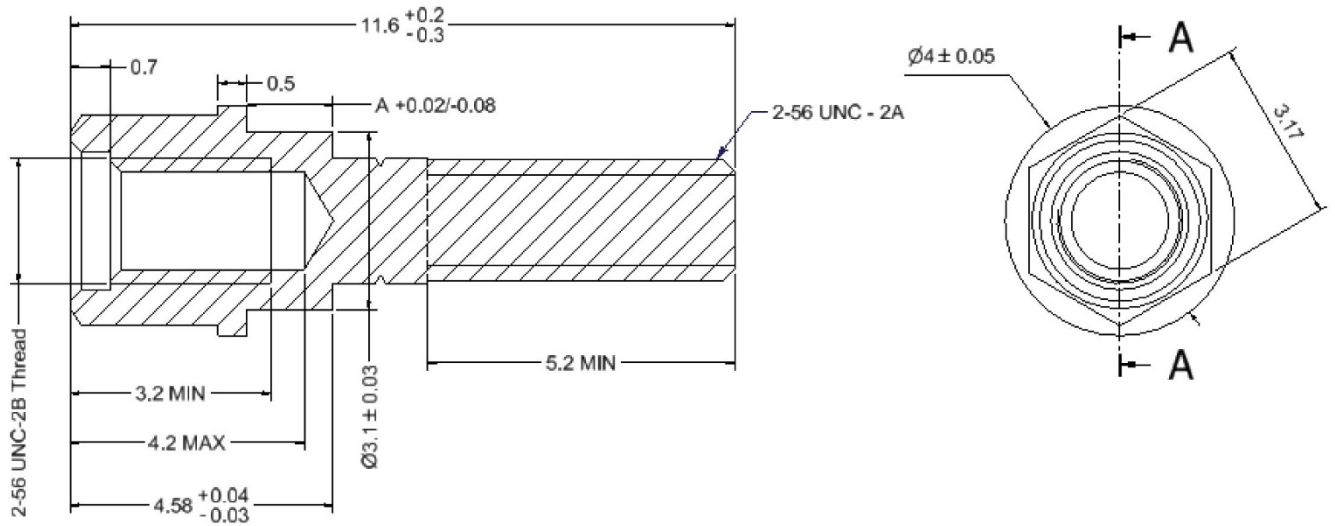

Nut

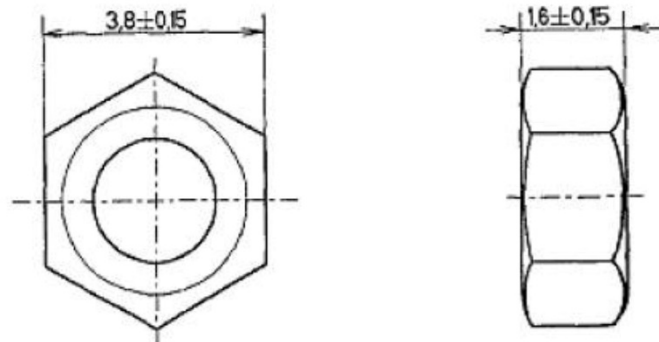

Lock-Washer

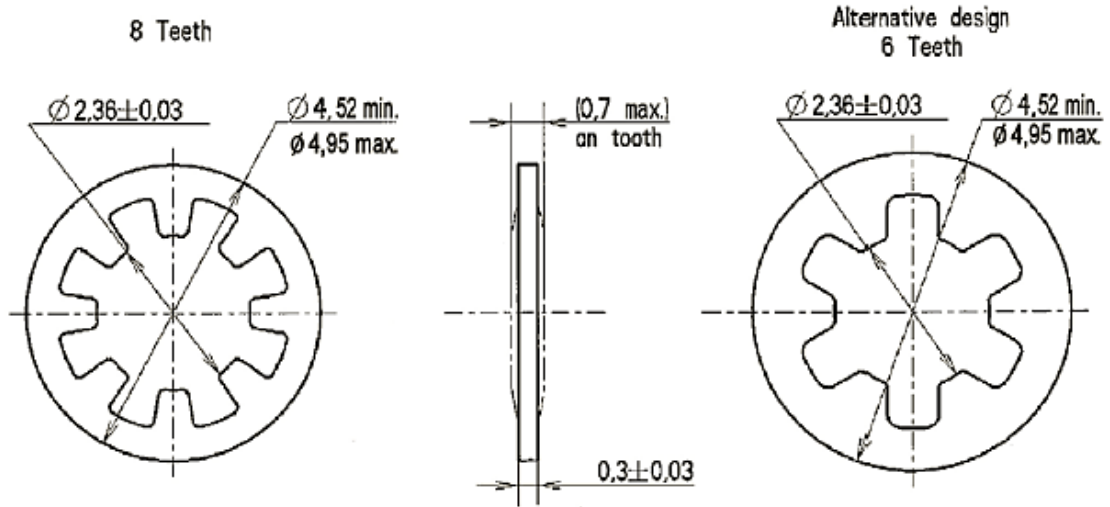

NOTES:

1. All dimensions in mm.
2. Weight:
 - Screwlock 0.45g
 - Nut 0.13g
 - Lock-Washer 0.02g
- 3.

Torque Values	Min (Nm)	Max (Nm)
Screwlock male side	0.44	0.48
Screwlock female side	0.28	0.32
Nut	0.44	0.48

VARIANT 27 – SCREWLOCK FOR CONNECTORS 75SB

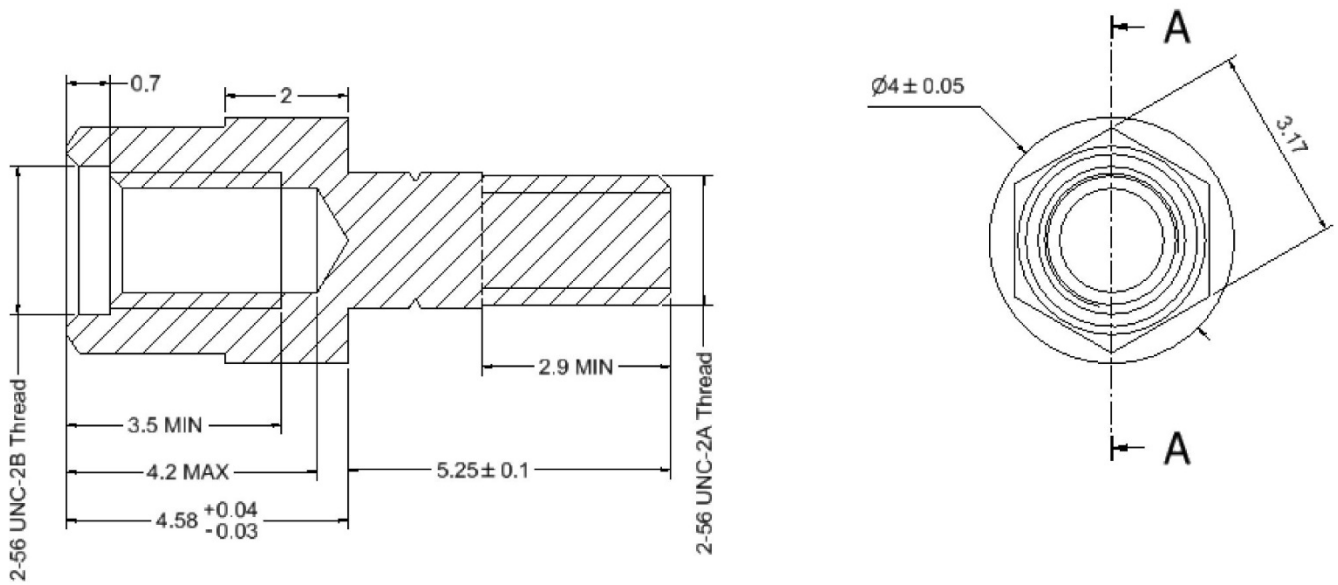

NOTES:

1. All dimensions in mm.
2. Weight:
 - Screwlock 0.43g
- 3.

Torque Values	Min (Nm)	Max (Nm)
Screwlock male side	0.44	0.48
Screwlock female side	0.28	0.32

VARIANTS 28 TO 32 – SCREWLOCK FOR CONNECTORS 75SB (REAR PANEL MOUNT)

Variant	28	29	30	31	32
Panel Thickness (+0.2 -0)	0.8	1.2	1.6	2	2.4
Dimension A	0.7	1.1	1.5	1.9	2.3

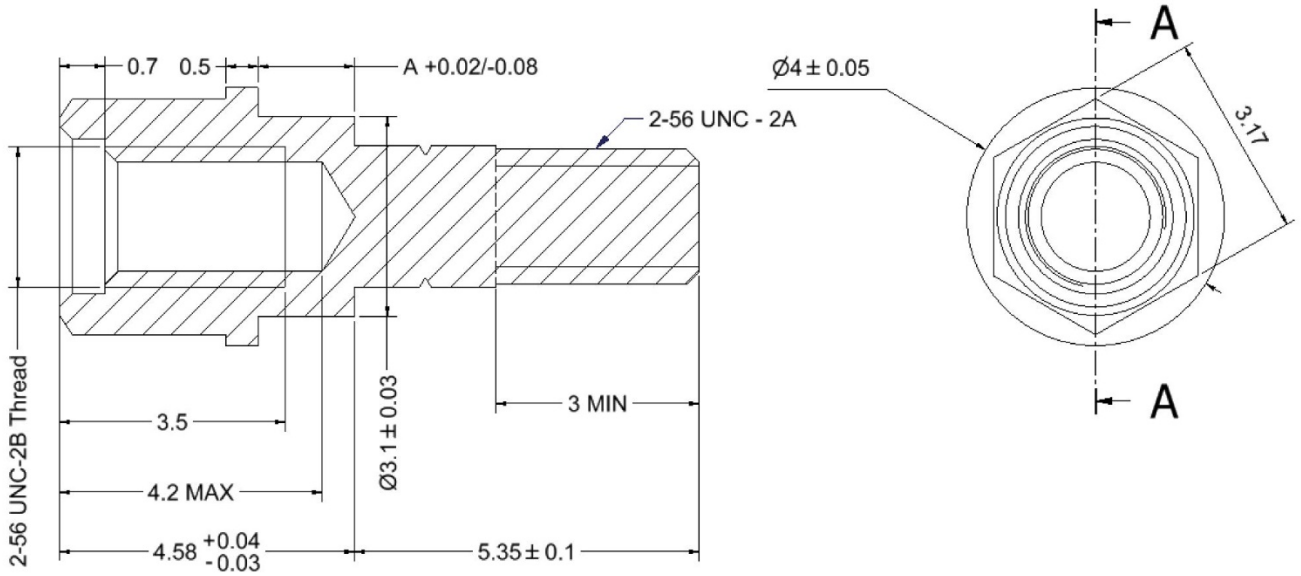

NOTES:

1. All dimensions in mm.
2. Weight:
 - Screwlock 0.43g
- 3.

Torque Values	Min (Nm)	Max (Nm)
Screwlock male side	0.44	0.48
Screwlock female side	0.28	0.32

VARIANT 33 – SCREWLOCK FOR CONNECTORS CBR/75RB

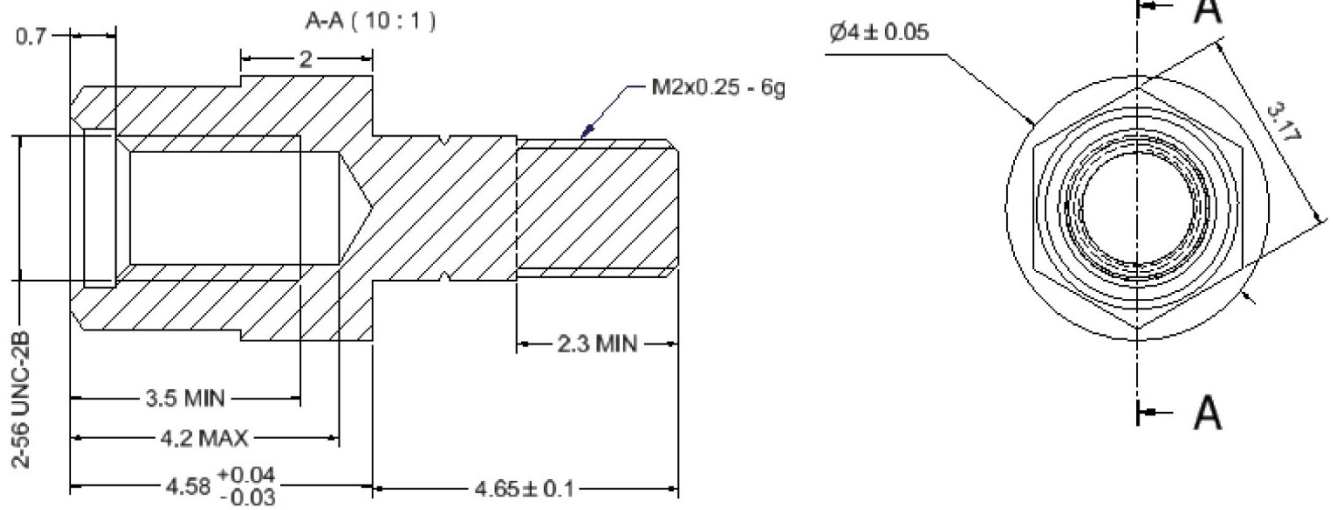

NOTES:

1. All dimensions in mm.
2. Weight:
 - Screwlock 0.43g
- 3.

Torque Values	Min (Nm)	Max (Nm)
Screwlock male side	0.44	0.48
Screwlock female side	0.28	0.32

VARIANTS 34 TO 38 – SCREWLOCK FOR CONNECTORS CBR/75RB (REAR PANEL MOUNT)

Variant	34	35	36	37	38
Panel Thickness (+0.2 -0)	0.8	1.2	1.6	2	2.4
Dimension A	0.7	1.1	1.5	1.9	2.3

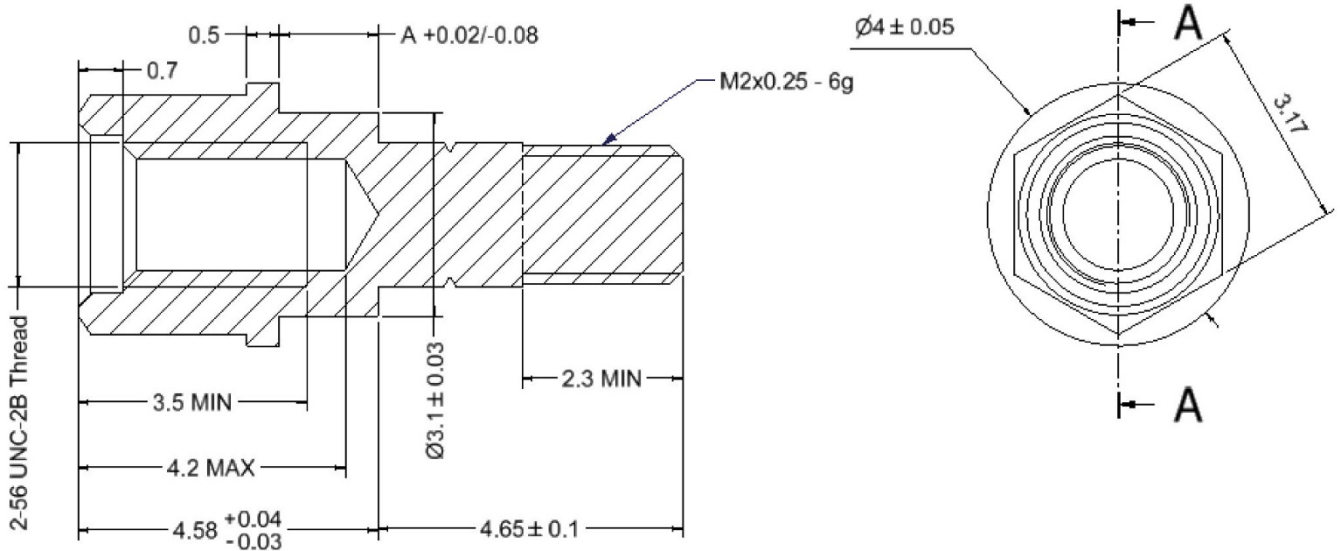

NOTES:

1. All dimensions in mm.
2. Weight:
 - Screwlock 0.43g
- 3.

Torque Values	Min (Nm)	Max (Nm)
Screwlock male side	0.44	0.48
Screwlock female side	0.28	0.32

2 APPLICABLE DOCUMENTS

The following documents form part of this specification and shall be read in conjunction with it:

- (a) ESCC Generic Specification No. [3401](#), Connectors, Electrical, Circular and Rectangular.
- (b) ESCC Detail Specification No. [3401/029](#), Connectors, Electrical, Rectangular, Microminiature, based on Type MDM.
- (c) ESCC Detail Specification No. [3401/041](#), Connector Savers, Electrical, Rectangular, Microminiature, based on type MDM.
- (d) ESCC Detail Specification No. [3401/077](#), Connectors, Electrical, Rectangular, Microminiature, Removable Contacts, based on Type MDMA.
- (e) ESCC Detail Specification No. [3401/087](#), Lightweight Accessories for Rectangular, Microminiature Connectors, [3401/029](#) and [3401/077](#).

3 TERMS, DEFINITIONS, ABBREVIATIONS, SYMBOLS AND UNITS

For the purpose of this specification, the terms, definitions, abbreviations, symbols and units specified in ESCC Basic Specification No. [21300](#) shall apply.

4 REQUIREMENTS

4.1 GENERAL

The complete requirements for procurement of the accessories specified herein are stated in this specification and ESCC Generic Specification No. 3401. Deviations from the Generic Specification, applicable to this specification only, are listed in Para. 4.2.

Deviations from the applicable Generic Specification and this Detail Specification, formally agreed with specific Manufacturers on the basis that the alternative requirements are equivalent to the ESCC requirements and do not affect the components' reliability, are listed in the appendices attached to this specification.

4.2 DEVIATIONS FROM GENERIC SPECIFICATION

4.2.1 Deviations from Special In-process Controls

Only Para. 5.2.1 shall apply.

4.2.2 Deviations from Final Production Tests (Chart II)

Only the following tests shall be performed:

- (a) Para. 9.6, Dimension Check.
- (b) Para. 9.7, External Visual Inspection. The magnification shall be x3.

4.2.3 Deviations from Burn-in and Electrical Measurements (Chart III)

Chart III is not applicable.

4.2.4 Deviations from Qualification, Environmental and Endurance Tests (Chart IV)

Chart IV is not applicable.

4.2.5 Deviations from Lot Acceptance Tests (Chart V)

Chart V is not applicable.

4.3 MECHANICAL REQUIREMENTS

4.3.1 Dimension Check

The dimensions of the accessories specified herein shall be verified in accordance with the requirements set out in Para. 9.6 of ESCC Generic Specification No. 3401 and Para. 4.2.2 of this specification; they shall conform to those shown in Figure 2.

4.3.2 Weight

The maximum weight of the accessories specified herein shall be as specified in Figure 2.

4.3.3 Torque Value

The torque value to be used for tightening the screws of the accessories specified herein shall be as specified in Table 1(b).

4.4 MATERIALS AND FINISHES

The materials and finishes shall be as specified herein. Where a definite material is not specified, a material which will enable the components specified herein to meet the performance requirements of this specification shall be used. Acceptance or approval of any constituent material does not guarantee acceptance of the finished product.

4.4.1 Screw Lock Assemblies and Brackets

These shall be made of passivated stainless steel, type 303.

4.4.2 Interfacial Seals

These shall be made of silicon base rubber.

4.5 MARKING

4.5.1 General

The marking of components delivered to this specification shall be in accordance with the requirements of ESCC Basic Specification No. [21700](#) and the following paragraphs. Each component shall be marked in respect of:

- (a) The ESCC qualified components symbol (for ESCC qualified components only).
- (b) The ESCC Component Number.
- (c) Traceability Information.

These components being too small to accommodate the marking specified above, the ESCC marking information shall accompany the component in its primary package.

4.5.2 The ESCC Component Number

The ESCC Component Number shall be constituted and marked as follows:

Example: 340103203B

- Detail Specification Number: 3401032
- Type Variant (See Figure 2): 03
- Testing Level: B

4.5.3 Traceability Information

Traceability information shall be marked in accordance with ESCC Basic Specification No. [21700](#).

4.6 ELECTRICAL MEASUREMENTS

Not applicable.

4.7 SCREENING TESTS (TABLES 4 AND 5)

Not applicable.

4.8 ENVIRONMENTAL AND ENDURANCE TESTS

Not applicable.