



Page 1 of 24

**CONNECTORS, ELECTRICAL, RECTANGULAR,  
MICROMINIATURE, REMOVABLE CRIMP CONTACTS**

**BASED ON TYPE MDMA**

**ESCC Detail Specification No. 3401/077**

Issue 7	April 2016
---------	------------



Document Custodian: European Space Agency – see <https://escies.org>

**LEGAL DISCLAIMER AND COPYRIGHT**

European Space Agency, Copyright © 2016. All rights reserved.

The European Space Agency disclaims any liability or responsibility, to any person or entity, with respect to any loss or damage caused, or alleged to be caused, directly by the use and application of this ESCC publication.

This publication, without the prior permission of the European Space Agency and provided that it is not used for a commercial purpose, may be:

- copied in whole, in any medium, without alteration or modification.
- copied in part, in any medium, provided that the ESCC document identification, comprising the ESCC symbol, document number and document issue, is removed.

**DOCUMENTATION CHANGE NOTICE**

(Refer to <https://escies.org> for ESCC DCR content)

DCR No.	CHANGE DESCRIPTION
976	Specification upissued to incorporate changes per DCR.

**TABLE OF CONTENTS**

1	GENERAL	6
1.1	SCOPE	6
1.2	COMPONENT TYPE VARIANTS AND RANGE OF COMPONENTS	6
1.3	MAXIMUM RATINGS	6
1.4	PARAMETER DERATING INFORMATION	6
1.5	PHYSICAL DIMENSIONS	6
1.6	CONTACT ARRANGEMENTS	6
2	APPLICABLE DOCUMENTS	6
3	TERMS, DEFINITIONS, ABBREVIATIONS, SYMBOLS AND UNITS	6
4	REQUIREMENTS	15
4.1	GENERAL	15
4.2	DEVIATIONS FROM GENERIC SPECIFICATION	15
4.2.1	Deviations from Special In-process Controls	15
4.2.2	Deviations from Final Production Tests (Chart II)	15
4.2.3	Deviations from Burn-in and Electrical Measurements (Chart III)	16
4.2.4	Deviations from Qualification Tests (Chart IV)	16
4.2.5	Deviations from Lot Acceptance Tests (Chart V)	16
4.3	MECHANICAL REQUIREMENTS	16
4.3.1	Dimension Check	16
4.3.2	Weight	16
4.3.3	Contact Capability	16
4.3.4	Contact Retention (In insert)	16
4.3.5	Mating and Unmating Forces	16
4.3.6	Insert Retention (In shell)	16
4.3.7	Jackscrew Retention	16
4.3.8	Contact Insertion and Withdrawal Forces	16
4.3.9	Engagement and Separation Forces (Male Contacts)	16
4.3.10	Oversize Pin Exclusion	16
4.3.11	Probe Damage	17
4.3.12	Solderability	17
4.4	MATERIALS AND FINISHES	17
4.4.1	Shells	17
4.4.2	Inserts	17
4.4.3	Contacts	17
4.4.4	Contact Retaining Clip	17
4.5	MARKING	17
4.5.1	General	17

4.5.2	The ESCC Component Number	17
4.5.3	Series	17
4.5.4	Characteristics	18
4.5.4.1	FIXING OPTION	18
4.5.4.2	SHELL SIZE	18
4.5.4.3	CONTACT TYPE	18
4.5.4.4	CONTACT INFORMATION	18
4.5.4.5	TRACEABILITY INFORMATION	18
4.6	ELECTRICAL MEASUREMENTS	18
4.6.1	Electrical Measurements at Room Temperature	18
4.6.2	Electrical Measurements at High and Low Temperatures	18
4.6.3	Circuits for Electrical Measurements	19
4.7	BURN-IN AND ELECTRICAL MEASUREMENTS (TABLES 4 AND 5)	19
4.8	ENVIRONMENTAL AND ENDURANCE TESTS (CHARTS IV AND V OF ESCC GENERIC SPECIFICATION NO. 3401)	20
4.8.1	Measurements and Inspections on Completion of Environmental Tests	20
4.8.2	Measurements and Inspections at Intermediate Points during Endurance Tests	20
4.8.3	Measurements and Inspections on Completion of Endurance Tests	20
4.8.4	Conditions for Operating Life Test (Part of Endurance Testing)	20
4.8.5	Electrical Circuit for Operating Life Test	20
4.8.6	Conditions for High Temperature Storage Test (Part of Endurance Testing)	20
APPENDIX A		24

## 1 GENERAL

### 1.1 SCOPE

This specification details the ratings, physical and electrical characteristics, test and inspection data for Electrical, Rectangular, Microminiature Connectors with Removable Crimp Contacts, based on type MDMA. It shall be read in conjunction with:

- ESCC Generic Specification No. 3401, Connectors, Electrical, Rectangular and Circular.
- ESCC Detail Specification No. 3401/032, Accessories for Connectors, Microminiature, 3401/029, 3401/077 and Connector Savers 3401/041.
- ESCC Detail Specification No. 3401/078, Contacts, Electrical, Crimp, for 3401/077 Microminiature Connectors based on type MDMA.
- ESCC Detail Specification No. 3401/087, Lightweight Accessories for Rectangular, Microminiature Connectors, 3401/029 and 3401/077.

the requirements of which are supplemented herein.

### 1.2 COMPONENT TYPE VARIANTS AND RANGE OF COMPONENTS

The different sizes of the basic type connectors specified herein, together with their mechanical characteristics, are scheduled in Table 1(a).

### 1.3 MAXIMUM RATINGS

The maximum ratings, which shall not be exceeded at any time during use or storage, applicable to the connectors specified herein, are given in Table 1(b).

### 1.4 PARAMETER DERATING INFORMATION

The derating information applicable to the connectors specified herein is shown in Figure 1.

### 1.5 PHYSICAL DIMENSIONS

The physical characteristics of the connectors specified herein are shown in Figure 2.

### 1.6 CONTACT ARRANGEMENTS

Contact arrangements are shown in Figure 3.

## 2 APPLICABLE DOCUMENTS

The following documents form part of this specification and shall be read in conjunction with it:

- (a) ESCC Generic Specification No. 3401, Connectors, Electrical, Circular and Rectangular.
- (b) ESCC Detail Specification No. 3401/032, Accessories for Connectors, Microminiature, 3401/029, 3401/077 and Connector Savers 3401/041.
- (c) ESCC Detail Specification No. 3401/078, Contacts, Electrical, Crimp for 3401/077 Microminiature Connectors based on type MDMA.
- (d) ESCC Detail Specification No. 3401/087, Lightweight Accessories for Rectangular, Microminiature Connectors, 3401/029 and 3401/077.
- (e) MIL-DTL-45204, Gold Plating, Electro-deposited.

## 3 TERMS, DEFINITIONS, ABBREVIATIONS, SYMBOLS AND UNITS

For the purpose of this specification, the terms, definitions, abbreviations, symbols and units specified in ESCC Basic Specification No. 21300 shall apply.

**TABLE 1(a) – COMPONENT TYPE VARIANTS AND RANGE OF COMPONENTS**

Variants		Shell Size Note 1	Weight Max. g Note 2	Mating Force N Max.	Unmating Force	
Shell Finish					N Max.	N Min.
Nickel	Gold					
01	02	9	2.3	20	20	1.3
01	02	15	3.1	33	33	2
01	02	21	3.9	47	47	2.9
01	02	25	4.4	55	55	3.5
01	02	31	5.2	69	69	4.3
01	02	37	6	82	82	5.1
01	02	51	7.3	147	147	7.1

**NOTES:**

1. See Figures 2.1(a) and 2.1(b).
2. Weight without cables, backshell, floating eyelets, captive nut and contacts (see Para. 4.5.4.4). Add 0.4 grammes for connectors with floating mounts and 1 gramme for connectors with captive nuts. See Figure 2.3 and ESCC Detail Specification Nos. 3901/002 and 3901/003 for the weight of cable and ESCC Detail Specification No. 3401/078 for contact weights.

**TABLE 1(b) - MAXIMUM RATINGS**

No.	Characteristic	Symbol	Maximum Rating	Unit	Remarks
1	Working Voltage	$U_R$	150	Vrms	Note 1
2	Rated Current with AWG24 wire	$I_R$	3.5	A	Note 2
	AWG26 and uninsulated solid wire		2.5		
	AWG28 wire		1.5		
3	Operating Temperature Range	$T_{op}$	-55 to +125	°C	$T_{amb}$
4	Storage Temperature Range	$T_{stg}$	-65 to +125	°C	-

**NOTES:**

1. At Sea Level, between contacts, and contact and shell.  $U_R$  requires derating at altitudes above sea level. See Figure 1(a).
2.  $I_R$  requires derating if the number of carrying contacts in the connector is 2 or greater. See Figure 1(b).

**FIGURE 1 - PARAMETER DERATING INFORMATION**

**FIGURE 1(a) - WORKING VOLTAGE VERSUS ALTITUDE**

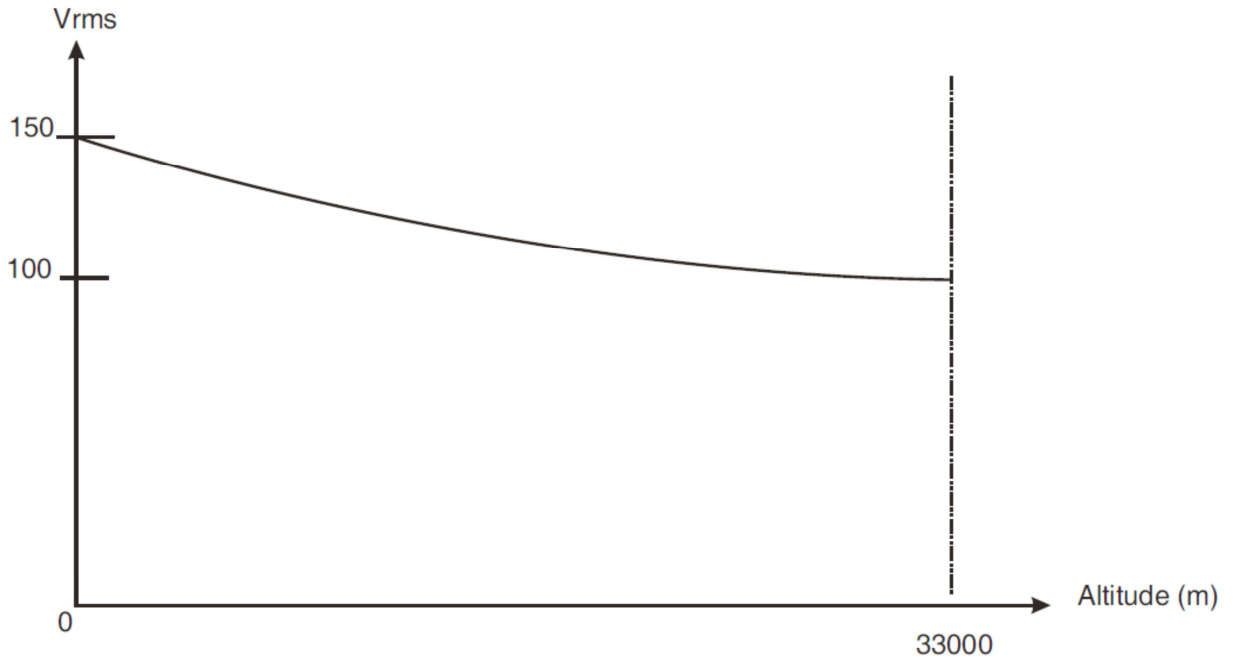

**FIGURE 1(b) - MAXIMUM CURRENT VERSUS NUMBER OF CONTACTS**

Number of Current-Carrying Contacts per Connector	Maximum Current per Contact (A)		
	Wire Size		
	AWG24	AWG26 and Uninsulated Solid Wire	AWG28
2 - 4	2.6	2	1.4
5 - 14	2.4	1.8	1.2
15 and over	1.9	1.4	0.9



**FIGURE 2 - PHYSICAL DIMENSIONS**

Figure 2.1(a) – Connector Shells - Plug (Male Contacts)

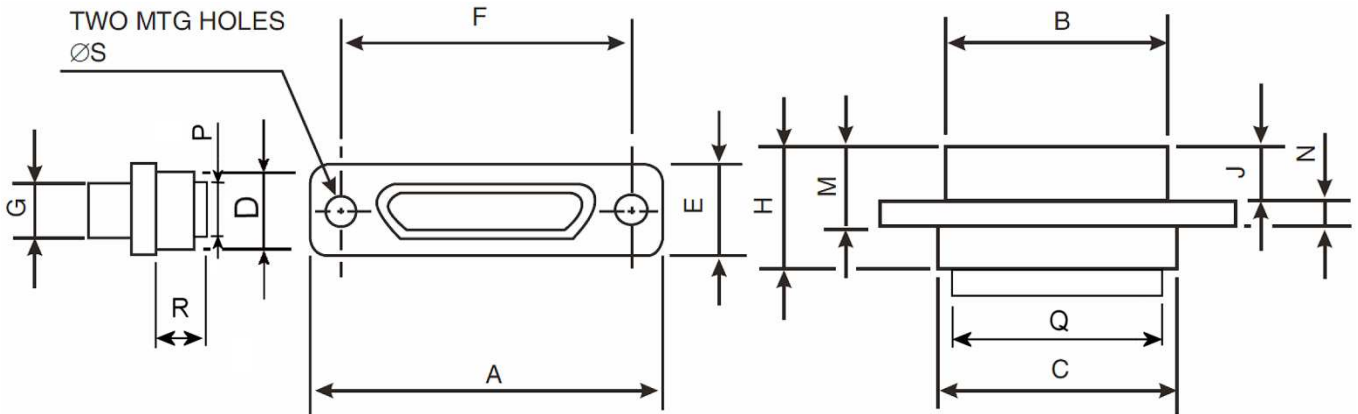

Shell Size	A Max.	B Max.	C Max.	D Max.	E Max.	F		G Max.	H Max.	J Max.	M Max.	N		ØS	
						Min.	Max.					Min.	Max.	Min.	Max.
9	19.94	8.46	10.16	6.86	7.82	14.22	14.48	4.69	10.57	4.72	7.26	2.23	2.49	2.23	2.39
15	23.75	12.27	13.97	6.86	7.82	18.03	18.29	4.69	10.57	4.72	7.26	2.23	2.49	2.23	2.39
21	27.56	16.08	17.78	6.86	7.82	21.84	22.1	4.69	10.57	4.72	7.26	2.23	2.49	2.23	2.39
25	30.1	18.62	20.32	6.86	7.82	24.38	24.64	4.69	10.57	4.72	7.26	2.23	2.49	2.23	2.39
31	33.91	22.43	24.13	6.86	7.82	28.19	28.45	4.69	10.57	4.72	7.26	2.23	2.49	2.23	2.39
37	37.72	26.24	27.94	6.86	7.82	32	32.26	4.69	10.57	4.72	7.26	2.23	2.49	2.23	2.39
51	36.45	24.97	26.67	7.87	8.92	30.73	30.99	5.78	10.57	4.72	7.26	2.23	2.49	2.23	2.39

Shell Size	P Max.	Q Max.	R Max.
9	4.4	7.8	5.7
15	4.4	11.6	5.7
21	4.4	15.4	5.7
25	4.4	17.95	5.7
31	4.4	21.75	5.7
37	4.4	25.6	5.7
51	5.3	24.3	5.7

**NOTES:**

1. All dimensions are in millimetres.

Figure 2.1(b) – Connector Shells - Receptacle (Female Contacts)

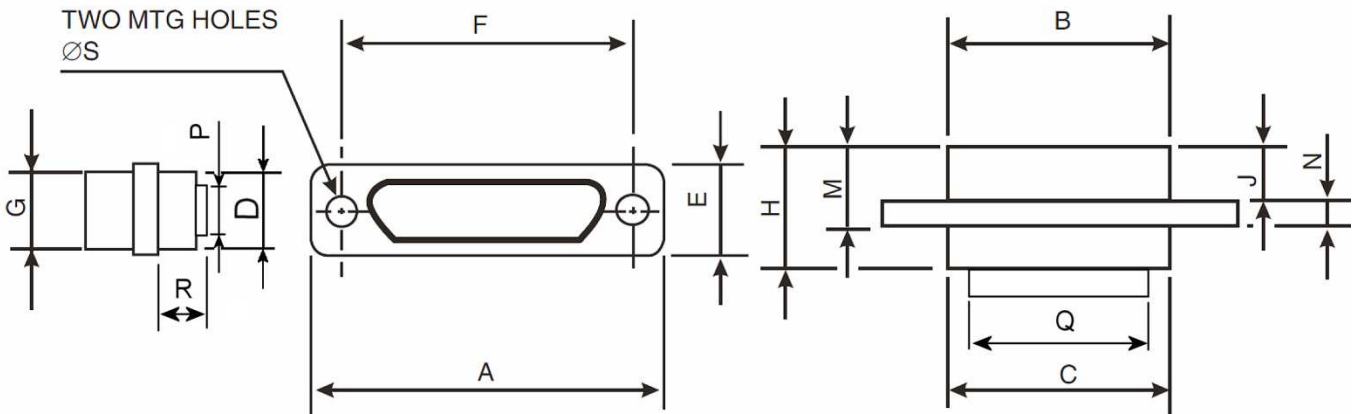

Shell Size	A	B	C	D	E	F		G	H	J	M	N		ØS	
	Max.	Max.	Max.	Max.	Max.	Min.	Max.	Max.	Max.	Max.	Max.	Min.	Max.	Min.	Max.
9	19.94	10.16	10.16	6.86	7.82	14.22	14.48	6.38	10.9	5.05	7.59	2.23	2.49	2.23	2.39
15	23.75	13.97	13.97	6.86	7.82	18.03	18.29	6.38	10.9	5.05	7.59	2.23	2.49	2.23	2.39
21	27.56	17.78	17.78	6.86	7.82	21.84	22.1	6.38	10.9	5.05	7.59	2.23	2.49	2.23	2.39
25	30.1	20.32	20.32	6.86	7.82	24.38	24.64	6.38	10.9	5.05	7.59	2.23	2.49	2.23	2.39
31	33.91	24.13	24.13	6.86	7.82	28.19	28.45	6.38	10.9	5.05	7.59	2.23	2.49	2.23	2.39
37	37.72	27.94	27.94	6.86	7.82	32	32.26	6.38	10.9	5.05	7.59	2.23	2.49	2.23	2.39
51	36.45	26.67	26.67	7.87	8.92	30.73	30.99	7.47	10.9	5.05	7.59	2.23	2.49	2.23	2.39

Shell Size	P	Q	R
	Max.	Max.	Max.
9	4.4	7.8	5.7
15	4.4	11.6	5.7
21	4.4	15.4	5.7
25	4.4	17.95	5.7
31	4.4	21.75	5.7
37	4.4	25.6	5.7
51	5.3	24.3	5.7

**NOTES:**

1. All dimensions are in millimetres.

**FIGURE 2.2 – CONTACT POSITIONS**

**Figure 2.2.1 – Mounting Condition**

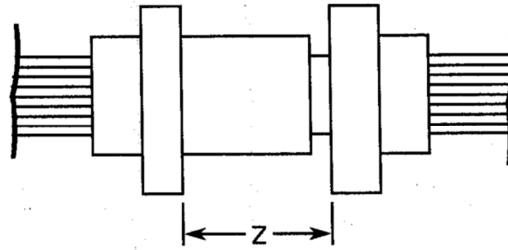

**Figure 2.2.2 – Plug Male Contact**

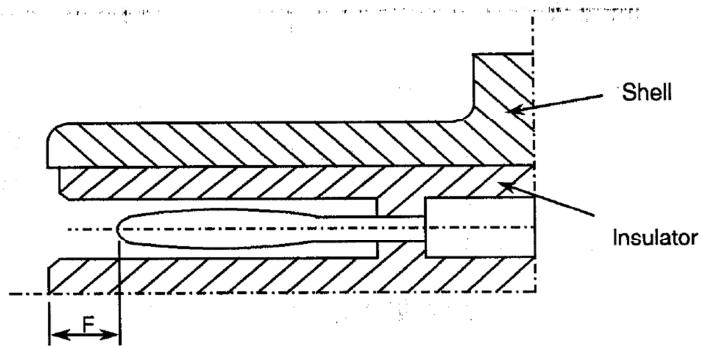

**Figure 2.2.3 – Receptacle Female Contact**

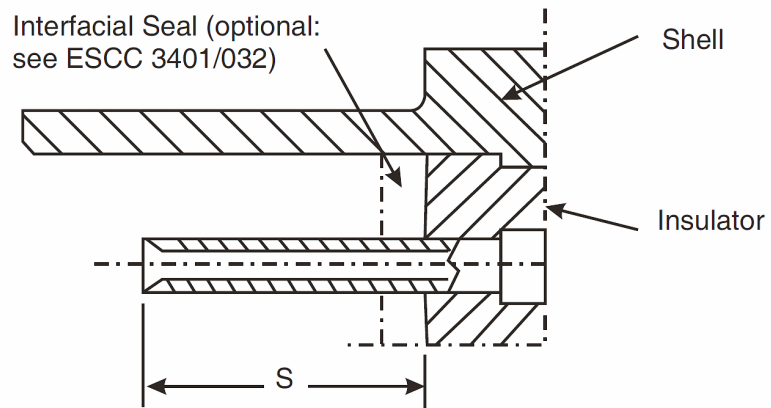

F		S		Z
Min.	Max.	Min.	Max.	Max.
0.25	0.91	3.3	3.66	5.49

**NOTES:**

1. All dimensions in millimetres.

**FIGURE 2.3 – UNINSULATED SOLID WIRES ACCEPTED**

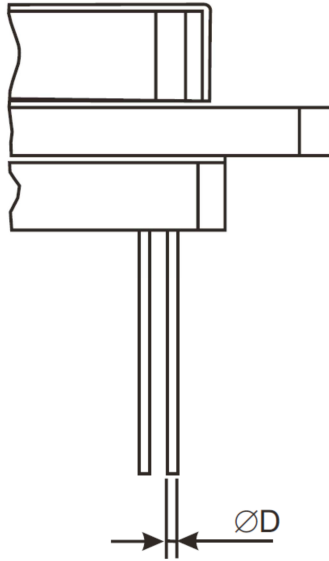

Wire Size AWG	25
Max Diameter D mm	0.51
Min Diameter D mm	0.4
Min Gold Plating Thickness $\mu\text{m}$	0.5
Max. Weight g/m	1.6

**FIGURE 2.4 – INSULATED SOLID WIRES ACCEPTED**

	ESCC 3901/002			ESCC 3901/013		
	Wire Size AWG					
	24	26	28	24 (1)	26	28
Maximum Conductor Diameter mm	0.64	0.53	0.43	0.62	0.5	0.42
Maximum Wire Diameter mm	0.88	0.78	0.68	1.04	0.89	0.82

**NOTES:**

1. Not applicable for shell size 51 (3 rows of contacts).

FIGURE 2.5 – FLOATING MOUNT (Notes 2 and 3)

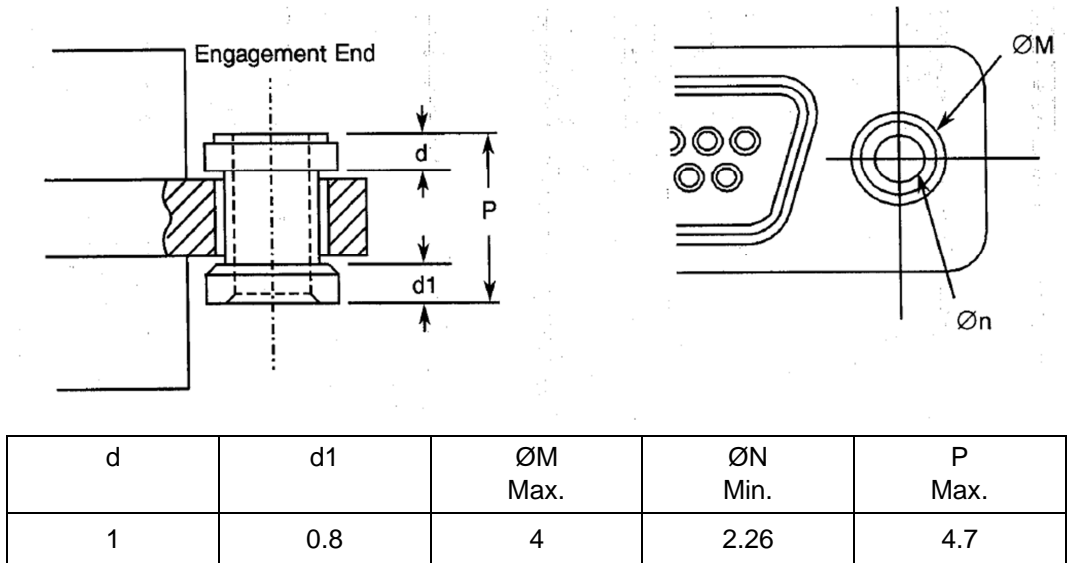

**NOTES:**

1. All dimensions are in millimetres.
2. Total Lateral Float 0.4 (typical).
3. Total Axial Float 0.4 (typical).

FIGURE 2.6 - CAPTIVE NUT

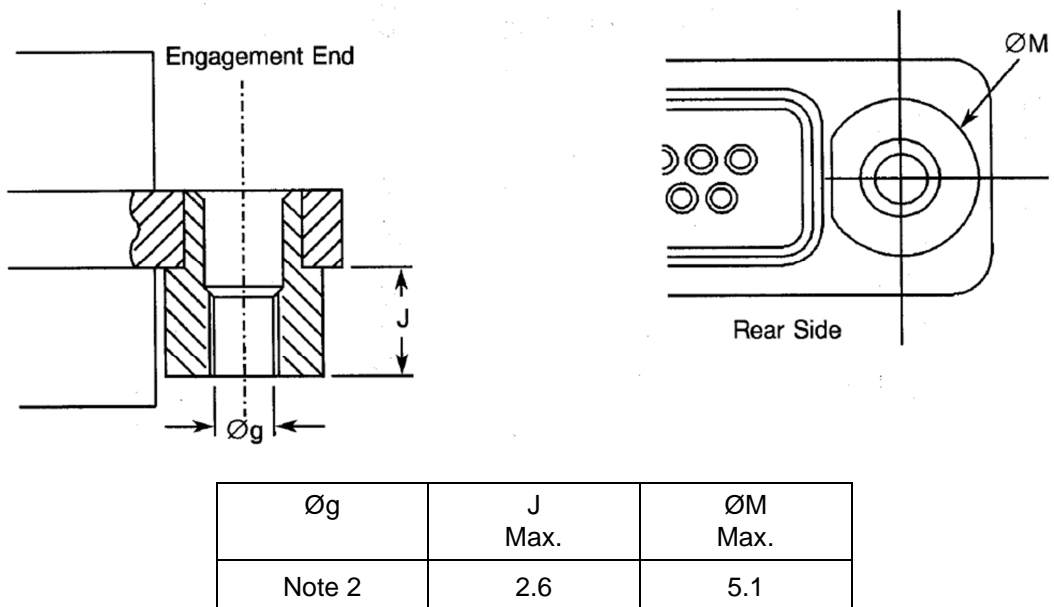

**NOTES:**

1. All dimensions are in millimetres.
2. Øg: 2-56 UNC 28, Maximum Torque 0.44Nm.

**FIGURE 3 – CONTACT ARRANGEMENTS**

**FRONT VIEW OF MALE INSERT – USE MIRROR VIEW FOR FEMALE INSERT**

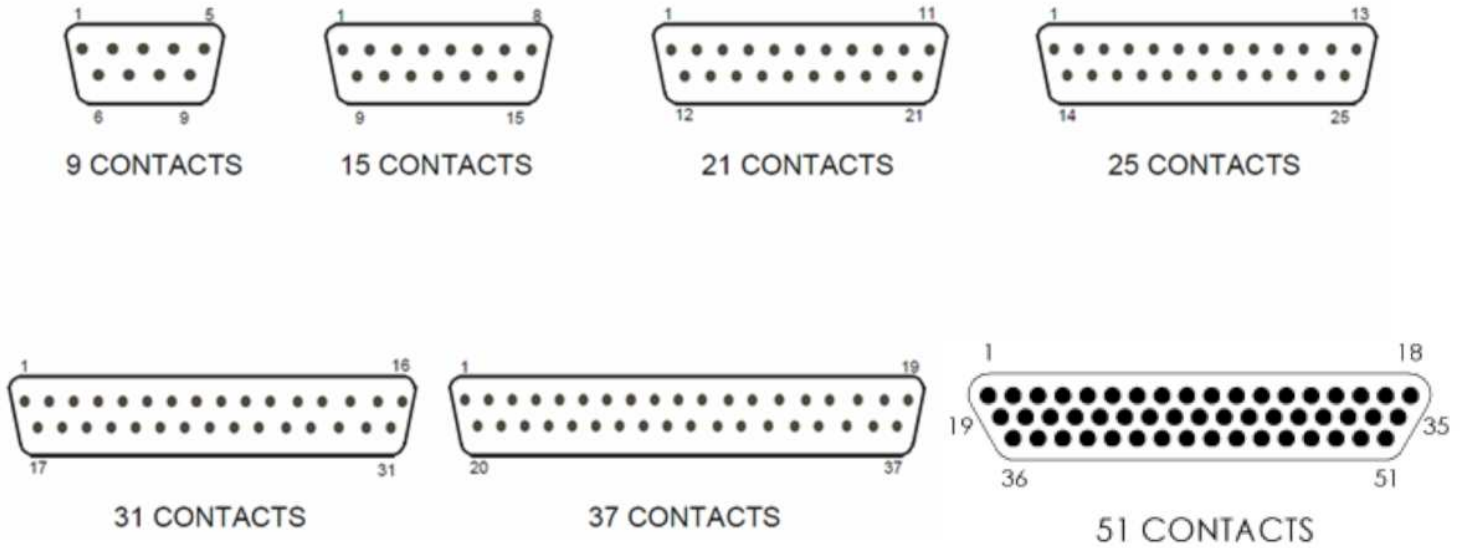

**NOTES:**

1. Only the outside contact cavities on each row are identified in the drawing, the remainder follow sequentially. Contact numbers are shown outside the insert for readability.

Contact Centres

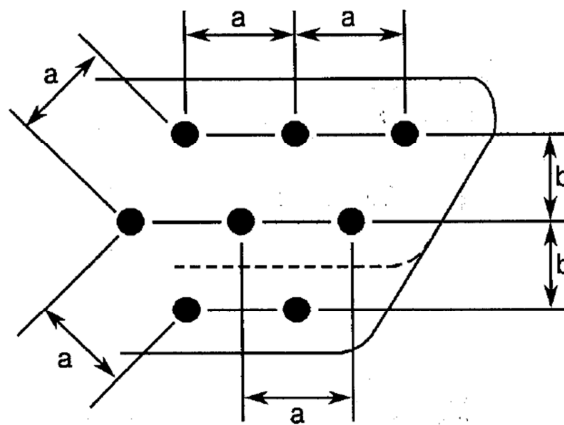

**NOTES:**

1. a = Distance between contact centres: 1.27mm (typical).
2. b = Distance between rows: 1.09mm (typical).

**FIGURE 4 – CONTACT REMOVAL TOOL**

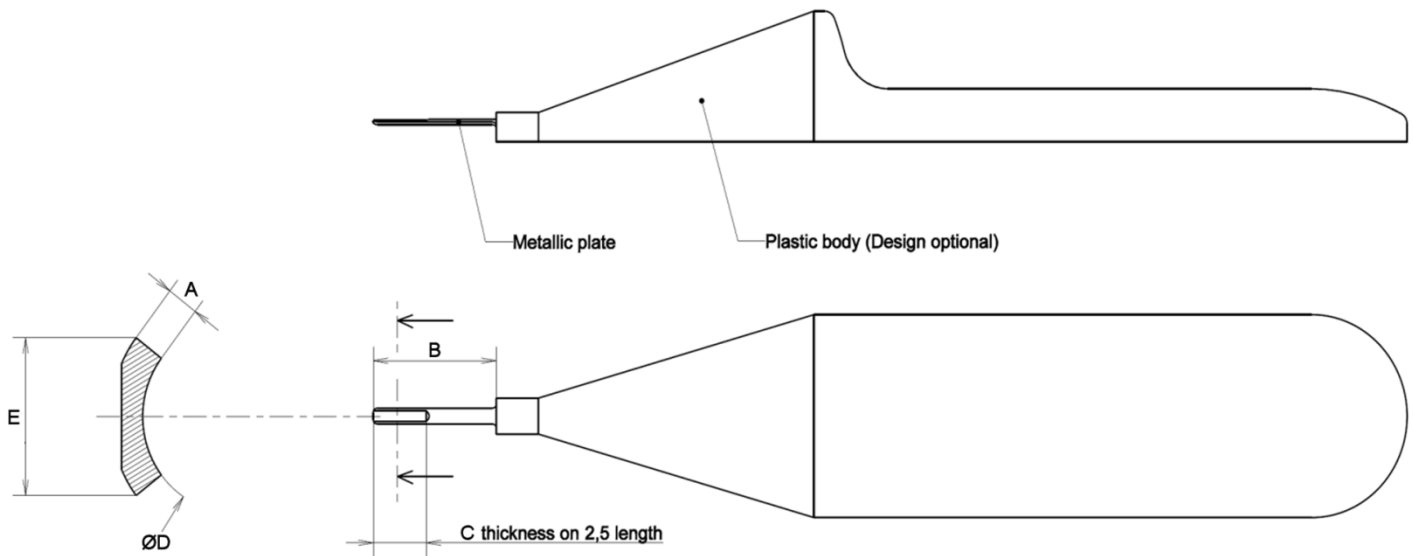

Shell Size	Dimensions (mm)									Notes
	A		B		C		ØD		E	
	Min	Max	Min	Max	Min	Max	Min	Max	Max.	
9 to 37	0.13	0.17	5.7	6	0.1	0.11	0.83	0.87	0.75	2 rows of contacts
51	0.07	0.09	5.7	6	0.06	0.07	0.83	0.87	0.75	3 rows of contacts

#### 4 **REQUIREMENTS**

##### 4.1 GENERAL

The complete requirements for procurement of the connectors specified herein are stated in this specification and ESCC Generic Specification No. 3401. Deviations from the Generic Specification, applicable to this specification only, are listed in Para. 4.2.

Deviations from the applicable Generic Specification and this Detail Specification, formally agreed with specific Manufacturers on the basis that the alternative requirements are equivalent to the ESCC requirements and do not affect the components' reliability, are listed in the appendices attached to this specification.

##### 4.2 DEVIATIONS FROM GENERIC SPECIFICATION

###### 4.2.1 Deviations from Special In-process Controls

None.

###### 4.2.2 Deviations from Final Production Tests (Chart II)

- (a) Para. 9.5, Magnetism Level: Not applicable.
- (b) Para. 9.2, Mating Verification: Not applicable.
- (c) Para. 9.3, Contact Retainer Test: Replaced by a 100% visual inspection with dedicated equipment.

4.2.3 Deviations from Burn-in and Electrical Measurements (Chart III)  
Chart III is not applicable.

4.2.4 Deviations from Qualification Tests (Chart IV)  
(a) Para. 9.9, Seal Test: Not applicable.  
(b) Para. 9.29, Oversize Pin Exclusion: Not applicable.  
(c) Para. 9.30, Probe Damage: Not applicable.  
(d) Para. 9.31, Solderability: Not applicable.

4.2.5 Deviations from Lot Acceptance Tests (Chart V)  
(a) Para. 9.9, Seal Test: Not applicable.  
(b) Para. 9.29, Oversize Pin Exclusion: Not applicable.  
(c) Para. 9.30, Probe Damage: Not applicable.

### 4.3 MECHANICAL REQUIREMENTS

4.3.1 Dimension Check  
The dimensions of the connectors specified herein shall be verified in accordance with the requirements set out in Para. 9.6 of ESCC Generic Specification No. 3401 and shall conform to those shown in Figure 2 of this specification. Only the underlined dimensions shall be checked during procurement.

4.3.2 Weight  
The maximum weight of the connectors specified herein, without contacts and interfacial seals, shall be in accordance with the values given in Table 1(a) of this specification.

4.3.3 Contact Capability  
As specified in ESCC Detail Specification No. 3401/078.

4.3.4 Contact Retention (In insert)  
As specified in ESCC Detail Specification No. 3401/078.

4.3.5 Mating and Unmating Forces  
The forces applied for the mating and unmating of the connectors shall conform to the values specified in Table 1(a).

4.3.6 Insert Retention (In shell)  
Connector inserts shall withstand a pressure of  $34.4\text{N/cm}^2$  applied from the mating side to the rear side.

4.3.7 Jackscrew Retention  
Not applicable.

4.3.8 Contact Insertion and Withdrawal Forces  
As specified in ESCC Detail Specification No. 3401/078 with removal tool defined in Figure 4.

4.3.9 Engagement and Separation Forces (Male Contacts)  
As specified in ESCC Detail Specification No. 3401/078.

4.3.10 Oversize Pin Exclusion  
Not applicable.



4.3.11 Probe Damage  
Not applicable.

4.3.12 Solderability  
Not applicable.

#### 4.4 MATERIALS AND FINISHES

The materials and finishes shall be as specified herein. Where a definite material is not specified, a material which will enable the components specified herein to meet the performance requirements of this specification shall be used. Acceptance or approval of any constituent material does not guarantee acceptance of the finished product.

4.4.1 Shells  
Shells shall be made of aluminium alloy. Variant 01 shall have a minimum plating thickness of 25.4µm of electroless nickel. The plating for Variant 02 shall be 0.7µm minimum of gold with 25.4µm minimum electroless nickel underplating.

4.4.2 Inserts  
Inserts shall be made of a suitable thermoplastic material.

4.4.3 Contacts  
As specified in ESCC Detail Specification No. 3401/078.

4.4.4 Contact Retaining Clip  
The retaining clip shall be made of beryllium copper or stainless steel.

#### 4.5 MARKING

4.5.1 General  
The marking of components delivered to this specification shall be in accordance with the requirements of ESCC Basic Specification No. 21700 and the following paragraphs.

Each component shall be marked in respect of:

- (a) The ESCC qualified components symbol (for ESCC qualified components only).
- (b) The ESCC Component Number.
- (c) Series.
- (d) Characteristics.
- (e) Traceability Information.

4.5.2 The ESCC Component Number  
Each component shall bear the ESCC Component Number which shall be constituted and marked as follows:

Example: 340107701B

- Detail Specification Number: 3401077
- Type Variant (See Table 1(a)): 01
- Testing Level: B

4.5.3 Series  
The series of the connector, MDMA, shall be marked on the connector if space permits.

#### 4.5.4 Characteristics

The characteristics to be marked in the following order of precedence are:

- (a) Mounting.
- (b) Shell Size.
- (c) Contact Type.
- (d) Contact Information.

The information shall be constituted and marked as follows (example): Y37P-FO

- Mounting: Y
- Shell size: 37
- Contact Type: P
- Contact Information: -FO

##### 4.5.4.1 *Fixing Option*

The letter "Y" shall indicate a floating mount. The letter "E" shall indicate captive nuts. If the shell has standard mounting holes, the letter shall be omitted.

##### 4.5.4.2 *Shell Size*

Shell size shall be designated by the number of contacts.

Specified numbers are: 9, 15, 21, 25, 31 and 37 and 51.

##### 4.5.4.3 *Contact Type*

Contact types shall be indicated by the following code letters.

Code Letter	Contact Type
P	Male
S	Female

##### 4.5.4.4 *Contact Information*

-FO = Connector ordered without contacts. This information shall not be marked on the connector; it is only included on the packaging and all relevant data documentation.

Contacts must be from the same Manufacturer as the connector in which they are fitted and this shall be verified prior to assembly.

##### 4.5.4.5 *Traceability Information*

Traceability information shall be marked in accordance with the requirements of ESCC Basic Specification No. 21700.

#### 4.6 ELECTRICAL MEASUREMENTS

##### 4.6.1 Electrical Measurements at Room Temperature

The parameters to be measured in respect of electrical characteristics are scheduled in Table 2. Unless otherwise specified, the measurements shall be performed at  $T_{amb} = +22 \pm 3^{\circ}\text{C}$ .

##### 4.6.2 Electrical Measurements at High and Low Temperatures

Not applicable.

4.6.3 Circuits for Electrical Measurements  
Not applicable.

4.7 BURN-IN AND ELECTRICAL MEASUREMENTS (TABLES 4 AND 5)  
Not applicable.

**TABLE 2 - ELECTRICAL MEASUREMENTS AT ROOM TEMPERATURE**

No.	Characteristic	Symbol	ESCC 3401 Test Method	Test Condition	Limits		Unit
					Min.	Max.	
1	Insulation Resistance	R <sub>i</sub>	Para. 9.1.1.1	Para. 9.1.1.1	5000 (Note 2)	-	MΩ
					2500 (Note 3)	-	
2	Voltage Proof Leakage Current	I <sub>L</sub>	Para. 9.1.1.2	600 Vrms Note 2	-	2	mA
				450 Vrms Note 3	-	2	
3	Mated Shell Conductivity (Voltage Drop) Note 1	V <sub>D</sub>	Para. 9.1.1.4	Para. 9.1.1.4	Not applicable		mV

**NOTES:**

1. Applicable to mated connectors with grounding option.
2. Applicable for shell sizes 9 to 37 (2 rows of contacts).
3. Applicable for shell size 51 (3 rows of contacts).

**TABLES 3, 4 AND 5**

Not applicable.

4.8 ENVIRONMENTAL AND ENDURANCE TESTS (CHARTS IV AND V OF ESCC GENERIC SPECIFICATION No. 3401)

4.8.1 Measurements and Inspections on Completion of Environmental Tests

The parameters to be measured and inspections to be performed on completion of environmental testing shall be those specified in Table 6. Unless otherwise specified, these measurements shall be performed at  $T_{amb} = +22 \pm 3^{\circ}\text{C}$ .

4.8.2 Measurements and Inspections at Intermediate Points during Endurance Tests

Not applicable.

4.8.3 Measurements and Inspections on Completion of Endurance Tests

The parameters to be measured and inspections to be performed on completion of endurance testing shall be those specified in Table 6. Unless otherwise specified, these measurements shall be performed at  $T_{amb} = +22 \pm 3^{\circ}\text{C}$ .

4.8.4 Conditions for Operating Life Test (Part of Endurance Testing)

Not applicable.

4.8.5 Electrical Circuit for Operating Life Test

Not applicable.

4.8.6 Conditions for High Temperature Storage Test (Part of Endurance Testing)

The requirements for the high temperature storage test are specified in Section 9 of ESCC Generic Specification No. 3401. The temperature to be applied shall be the maximum storage temperature specified in Table 1(b) of this specification.

**TABLE 6 – MEASUREMENTS AND INSPECTIONS ON COMPLETION OF ENVIRONMENTAL AND ENDURANCE TESTING**

No.	ESCC Generic Spec. No. 3401		Measurements and Inspections		Symbol	Limits		Unit
	Environmental and Endurance Tests Note 1	Test Method and Conditions	Identification	Conditions		Min.	Max.	
01	Seal Test	Para. 9.9	Not applicable	-	-	-	-	
02	Wiring	Para. 9.10	ESCC 3401/078	-	-	-	-	
03	Vibration	Para. 9.11	<b>Initial Measurements</b> Coupling Screw(s) Unlocking Torque		Tqe	Record Values		
			<b>Final Measurements</b> Full Engagement Coupling Screw(s) Unlocking Torque Drift Visual Examination	- - -	$\Delta Tqe/Tqe$ - -	-25 - -	+25 - -	%
04	Shock or Bump	Para. 9.12	Full Engagement Visual Examination	- -	- -	- -	- -	

No.	ESCC Generic Spec. No. 3401		Measurements and Inspections		Symbol	Limits		Unit
	Environmental and Endurance Tests Note 1	Test Method and Conditions	Identification	Conditions		Min.	Max.	
05	Climatic Sequence	Para. 9.13	<b>Dry Heat</b> Insulation Resistance	At High Temperature Table 2, Item 1	R <sub>i</sub>	10	-	MΩ
			<b>Low Air Pressure</b> Voltage Proof Leakage Current	Figure 1	I <sub>L</sub>	ESCC 3401 Para. 9.13.5		mA
			<b>Damp Heat</b> Insulation Resistance	Immediately after test Table 2, Item 1	R <sub>i</sub>	100	-	MΩ
			<b>Final Measurements</b> External Visual Inspection	After 1-24 hrs Recovery ESCC 3401 Para. 9.7	-	ESCC 3401 Para. 9.7		
			Insulation Resistance	Table 2, Item 1	R <sub>i</sub>	Table 2, Item 1		MΩ
			Voltage Proof Leakage Current	Table 2, Item 2	I <sub>L</sub>	Table 2, Item 2		mA
06	Plating Thickness	Para. 9.14	Thickness	-	-	-		
07	Joint Strength	Para. 9.15	ESCC 3401/078	-	-	-		
08	Rapid Change of Temperature	Para. 9.16	Visual Examination	-	-	-	-	
			Insulation Resistance	Table 2, Item 1	R <sub>i</sub>	Table 2, Item 1		MΩ
			Voltage Proof Leakage Current	Table 2, Item 2	I <sub>L</sub>	Table 2, Item 2		mA
09	Contact Retention (in Insert)	Para. 9.17 & Para. 4.3.4 of this spec.	Contact Displacement	ESCC 3401/078	-	ESCC 3401/078		
10	Endurance	Para. 9.18	<b>Initial Measurements</b> Mating/Unmating Forces	-	F	Para. 4.3.5 of this spec.		N
			Low Level Contact Resistance	ESCC 3401/078	R <sub>cd</sub>	ESCC 3401/078		mΩ
			Mated Shell Conductivity	Table 2, Item 3	V <sub>D</sub>	Not applicable		mV
			<b>Final Measurements</b> Visual Examination	-	-	-	-	
			Mating/Unmating Forces	-	F	Para. 4.3.5 of this spec.		N
			Low Level Contact Resistance Drift	ESCC 3401/078	ΔR <sub>cd</sub>	ESCC 3401/078		mΩ
			Mated Shell Conductivity	Table 2, Item 3	V <sub>D</sub>	Not applicable		mV
			Insulation Resistance	Table 2, Item 1	R <sub>i</sub>	Table 2, Item 1		MΩ
			Voltage Proof Leakage Current	Table 2, Item 2	I <sub>L</sub>	Table 2, Item 2		mA
11	Permanence of Marking	Para. 9.19	As applicable	-	-	-		

No.	ESCC Generic Spec. No. 3401		Measurements and Inspections		Symbol	Limits		Unit
	Environmental and Endurance Tests Note 1	Test Method and Conditions	Identification	Conditions		Min.	Max.	
12	Mating / Unmating Forces	Para. 9.20	Force	-	F	Para. 4.3.5 of this spec.		N
13	High Temperature Storage	Para. 9.21	<b>Initial Measurements</b>					
			Low Level Contact Resistance	ESCC 3401/078	R <sub>cl</sub>	ESCC 3401/078	mΩ	
			Mated Shell Conductivity	Table 2, Item 3	V <sub>D</sub>	Not applicable	mV	
			<b>Final Measurements</b>					
			Visual Examination	-	-	-   -		
			Mating/Unmating Forces	-	F	Para. 4.3.5 of this spec.	N	
			Low Level Contact Resistance Drift	ESCC 3401/078	ΔR <sub>cl</sub>	ESCC 3401/078	mΩ	
			Rated Current Contact Resistance	ESCC 3401/078	R <sub>cr</sub>	ESCC 3401/078	mΩ	
			Mated Shell Conductivity	Table 2, Item 3	V <sub>D</sub>	Not applicable	mV	
			Insulation Resistance	Table 2, Item 1	R <sub>i</sub>	Table 2, Item 1	MΩ	
	Voltage Proof Leakage Current	Table 2, Item 2	I <sub>L</sub>	Table 2, Item 2	mA			
	Contact Retention (In Insert)	ESCC 3401/078		ESCC 3401/078	N			
14	Corrosion	Para. 9.22	Visual Examination	-	-	-	-	
15	Insert Retention (In Shell)	Para. 9.23 & Para. 4.3.6 of this spec.	Visual Examination	-	-	Para. 4.3.6 of this spec.		
16	Jackscrew Retention	Para. 9.24 & Para. 4.3.7 of this spec.	Not applicable	-	-	-	-	
17	High Temperature Measurements	Para. 9.25	Insulation Resistance	Table 2 Item 1	R <sub>i</sub>	10	-	MΩ
18	Overload Test	Para. 9.26	Internal Temperature	-	T	-	+100	°C
			Rated Current Contact Resistance	ESCC 3401/078	R <sub>cr</sub>	ESCC 3401/078		mΩ
			Mated Shell Conductivity	Table 2 Item 3	V <sub>D</sub>	Not applicable		mV
			Insulation Resistance	Table 2 Item 1	R <sub>i</sub>	Table 2, Item 1		MΩ
			Voltage Proof Leakage Current	Table 2 Item 2	I <sub>L</sub>	Table 2, Item 2		mA
19	Maintenance Ageing	Para. 9.27	Visual Examination	-	-	-	-	
			Contact Retention (In insert)	ESCC 3401/078	-	ESCC 3401/078		N
			Contact insertion and Withdrawal Forces	ESCC 3401/078		ESCC 3401/078		N

No.	ESCC Generic Spec. No. 3401		Measurements and Inspections		Symbol	Limits		Unit
	Environmental and Endurance Tests Note 1	Test Method and Conditions	Identification	Conditions		Min.	Max.	
20	Engage/Separation Forces	Para. 9.28 & Para. 4.3.9 of this spec.	Force	ESCC 3401/078	F	ESCC 3401/078		N
21	Oversize Pin Exclusion	Para. 9.29 & Para. 4.3.10 of this spec.	Not applicable	-	-	-	-	
22	Probe Damage	Para. 9.30 & Para. 4.3.11 of this spec.	Not applicable	-	-	-	-	
23	Solderability	Para. 9.31 & Para. 4.3.12 of this spec.	Not applicable	-	-	-	-	

**NOTES:**

1. The tests in this Table refer to either Chart IV or V and shall be used as applicable.

**APPENDIX A**  
**AGREED DEVIATIONS FOR C&K COMPONENTS (F)**

ITEMS AFFECTED	DESCRIPTION OF DEVIATIONS
Deviations from Final Production Tests (Chart II)	Para. 9.4, Contact Capability: 100% Contact Capability Test may be omitted provided that a 100% visual inspection of the contacts is performed on each batch submitted to tests defined in the C&K PID requirements.