



**ACCESSORIES FOR RECTANGULAR
CONNECTORS, MICROMINIATURE, 3401/081 AND
3401/082**

ESCC Detail Specification No. 3401/084

Issue 3	November 2017
---------	---------------



LEGAL DISCLAIMER AND COPYRIGHT

European Space Agency, Copyright © 2017. All rights reserved.

The European Space Agency disclaims any liability or responsibility, to any person or entity, with respect to any loss or damage caused, or alleged to be caused, directly or indirectly by the use and application of this ESCC publication.

This publication, without the prior permission of the European Space Agency and provided that it is not used for a commercial purpose, may be:

- copied in whole, in any medium, without alteration or modification.
- copied in part, in any medium, provided that the ESCC document identification, comprising the ESCC symbol, document number and document issue, is removed.

DOCUMENTATION CHANGE NOTICE

(Refer to <https://escies.org> for ESCC DCR content)

DCR No.	CHANGE DESCRIPTION
1095	Specification upissued to incorporate changes per DCR.

TABLE OF CONTENTS

1	GENERAL	5
1.1	SCOPE	5
1.2	TYPE VARIANTS	5
1.3	MAXIMUM RATINGS	5
1.4	PARAMETER DERATING INFORMATION	5
1.5	PHYSICAL DIMENSIONS	5
2	APPLICABLE DOCUMENTS	5
3	TERMS, DEFINITIONS, ABBREVIATIONS, SYMBOLS AND UNITS	5
4	REQUIREMENTS	31
4.1	GENERAL	31
4.2	DEVIATIONS FROM GENERIC SPECIFICATION	31
4.2.1	Deviations from Special In-Process Controls	31
4.2.2	Deviations from Final Production Tests (Chart II)	31
4.2.3	Deviations from Burn-in and Electrical Measurements (Chart III)	31
4.2.4	Deviations from Qualification, Environmental and Endurance Tests (Chart IV)	31
4.2.5	Deviations from Lot Acceptance Tests (Chart V)	31
4.3	MECHANICAL REQUIREMENTS	31
4.3.1	Dimension Check	31
4.3.2	Weight	31
4.3.3	Torque Value	31
4.4	MATERIALS AND FINISHES	31
4.4.1	Screw Lock Assemblies (Jackpost, Jackscrew)	32
4.4.2	Clips	32
4.4.3	Backshells	32
4.4.4	Dust Caps	32
4.5	MARKING	32
4.5.1	General	32
4.5.2	The ESCC Component Number	32
4.5.3	Traceability Information	32
4.6	ELECTRICAL MEASUREMENTS	32
4.7	SCREENING TESTS (TABLES 4 AND 5)	32
4.8	ENVIRONMENTAL AND ENDURANCE TESTS	32

1 GENERAL

1.1 SCOPE

This specification details the ratings, physical and electrical characteristics, test and inspection data of Accessories for Rectangular Connectors, Microminiature, [3401/081](#) and [3401/082](#).

It shall be read in conjunction with:

- ESCC Generic Specification No. [3401](#), Connectors, Electrical, Non-Filtered, Circular and Rectangular.
- ESCC Detail Specification No. [3401/081](#), Connectors, Electrical, Rectangular, Microminiature, Non-removable Gauge 26 PCB Pin Contacts based on Type 8MCG.
- ESCC Detail Specification No. [3401/082](#), Connectors, Electrical, Rectangular, Microminiature, Removable Gauge 26 Crimp Contacts based on Type 8MCG.

the requirements of which are supplemented herein.

1.2 TYPE VARIANTS

The type variants of accessories covered by this specification are given in Table 1(a).

1.3 MAXIMUM RATINGS

The maximum ratings, which shall not be exceeded at any time during use or storage, applicable to the accessories specified herein, are as scheduled in Table 1(b).

1.4 PARAMETER DERATING INFORMATION

Not applicable.

1.5 PHYSICAL DIMENSIONS

The physical dimensions of the accessories specified herein are shown in Figure 2.

2 APPLICABLE DOCUMENTS

The following documents form part of this specification and shall be read in conjunction with it:

- ESCC Generic Specification No. [3401](#), Connectors, Electrical Non-filtered, Circular and Rectangular.
- ESCC Detail Specification No. [3401/081](#), Connectors, Electrical, Rectangular, Microminiature, Non-removable Gauge 26 PCB Pin Contacts, based on Type 8MCG.
- ESCC Detail Specification No. [3401/082](#), Connectors, Electrical, Rectangular, Microminiature, Removable Gauge 26 Crimp Contacts, based on type 8MCG.

3 TERMS, DEFINITIONS, ABBREVIATIONS, SYMBOLS AND UNITS

For the purpose of this specification, the terms, definitions, abbreviations, symbols and units specified in ESCC Basic Specification No. [21300](#) shall apply.

TABLE 1(a) - TYPE VARIANTS

Type Variants	Descriptions	Applicable Shell Sizes	Weight Max (g)	Torque Values (Nm)		Remarks
				Min	Max	
01	Jackscrew assembly (screw and retaining ring), allen head screw, low profile	A, B, C, D, E, F, G, H	0.3	0.28	0.32	
02	Jackscrew assembly (screw and retaining ring), slot head screw, low profile	A, B, C, D, E, F, G, H	0.3	0.28	0.32	
03	Jackpost assembly (screwlock, nut and lockwasher)	A, B, C, D, E, F, G, H	0.62	0.44 0.28 0.44	0.48 0.32 0.48	See Note 1 See Note 2 See Note 3
04	Jackscrew assembly (screw and retaining ring), allen head screw, low profile	J	0.35	0.4	0.44	
05	Jackscrew assembly (screw and retaining ring), slot head screw, low profile	J	0.35	0.4	0.44	
06	Jackpost assembly (screwlock, nut and lockwasher)	J	0.9	0.6 0.4 0.6	0.66 0.44 0.66	See Note 1 See Note 2 See Note 3
07	Jackscrew assembly (jackscrew and clip), allen head screw, low profile	A, B, C, D, E, F, G, H	0.8	0.28	0.32	
08	Jackscrew assembly (jackscrew and clip), allen head screw, low profile	J	1.1	0.4	0.44	
09	Straight backshell with male jackscrews and clips	A	2.7	-	-	See Note 4
10	Straight backshell with male jackscrews and clips	B	3	-	-	See Note 4
11	Straight backshell with male jackscrews and clips	C	3.95	-	-	See Note 4
12	Straight backshell with male jackscrews and clips	D	4.75	-	-	See Note 4
13	Straight backshell with male jackscrews and clips	E	5.5	-	-	See Note 4
14	Straight backshell with male jackscrews and clips	F	6.15	-	-	See Note 4
15	Straight backshell with male jackscrews and clips	G	7.35	-	-	See Note 4
16	Straight backshell with female jackposts and nuts	A	2.7	-	-	See Note 5

Type Variants	Descriptions	Applicable Shell Sizes	Weight Max (g)	Torque Values (Nm)		Remarks
				Min	Max	
17	Straight backshell with female jackposts and nuts	B	3	-	-	See Note 5
18	Straight backshell with female jackposts and nuts	C	3.95	-	-	See Note 5
19	Straight backshell with female jackposts and nuts	D	4.75	-	-	See Note 5
20	Straight backshell with female jackposts and nuts	E	5.5	-	-	See Note 5
21	Straight backshell with female jackposts and nuts	F	6.15	-	-	See Note 5
22	Straight backshell with female jackposts and nuts	G	7.35	-	-	See Note 5
23	Angled backshell with male jackscrews and clips	A	4.1	-	-	See Note 4
24	Angled backshell with male jackscrews and clips	B	4.95	-	-	See Note 4
25	Angled backshell with male jackscrews and clips	C	5.85	-	-	See Note 4
26	Angled backshell with male jackscrews and clips	D	6.75	-	-	See Note 4
27	Angled backshell with male jackscrews and clips	E	7.4	-	-	See Note 4
28	Angled backshell with male jackscrews and clips	F	8.55	-	-	See Note 4
29	Angled backshell with male jackscrews and clips	G	9.15	-	-	See Note 4
30	Angled backshell with male jackscrews and clips	A	4.1	-	-	See Note 5
31	Angled backshell with female jackposts and nuts	B	4.95	-	-	See Note 5
32	Angled backshell with female jackposts and nuts	C	5.85	-	-	See Note 5
33	Angled backshell with female jackposts and nuts	D	6.75	-	-	See Note 5
34	Angled backshell with female jackposts and nuts	E	7.4	-	-	See Note 5
35	Angled backshell with female jackposts and nuts	F	8.55	-	-	See Note 5

Type Variants	Descriptions	Applicable Shell Sizes	Weight Max (g)	Torque Values (Nm)		Remarks
				Min	Max	
36	Angled backshell with female jackposts and nuts	G	9.15	-	-	See Note 5
37	90° backshell with male jackscrews and clips	A	4.1	-	-	See Note 4
38	90° backshell with male jackscrews and clips	B	4.95	-	-	See Note 4
39	90° backshell with male jackscrews and clips	C	5.85	-	-	See Note 4
40	90° backshell with male jackscrews and clips	D	6.75	-	-	See Note 4
41	90° backshell with male jackscrews and clips	E	7.4	-	-	See Note 4
42	90° backshell with male jackscrews and clips	F	8.35	-	-	See Note 4
43	90° backshell with male jackscrews and clips	G	9.15	-	-	See Note 4
44	90° backshell with female jackposts and nuts	A	4.1	-	-	See Note 5
45	90° backshell with female jackposts and nuts	B	4.95	-	-	See Note 5
46	90° backshell with female jackposts and nuts	C	5.85	-	-	See Note 5
47	90° backshell with female jackposts and nuts	D	6.75	-	-	See Note 5
48	90° backshell with female jackposts and nuts	E	7.4	-	-	See Note 5
49	90° backshell with female jackposts and nuts	F	8.35	-	-	See Note 5
50	90° backshell with female jackposts and nuts	G	9.15	-	-	See Note 5
51	Straight backshell with male jackscrews and clips	H	7.5	-	-	See Note 4
52	Straight backshell with male jackscrews and clips	J	11.5	-	-	See Note 6
53	Straight backshell with female jackposts and nuts	H	7.5	-	-	See Note 5
54	Straight backshell with female jackposts and nuts	J	11.5	-	-	See Note 7

Type Variants	Descriptions	Applicable Shell Sizes	Weight Max (g)	Torque Values (Nm)		Remarks
				Min	Max	
55	Angled backshell with male jackscrews and clips	H	9.5	-	-	See Note 4
56	Angled backshell with male jackscrews and clips	J	15.2	-	-	See Note 6
57	Angled backshell with female jackposts and nuts	H	9.5	-	-	See Note 5
58	Angled backshell with female jackposts and nuts	J	15.2	-	-	See Note 7
59	90° backshell with male jackscrews and clips	H	9.5	-	-	See Note 4
60	90° backshell with male jackscrews and clips	J	15.2	-	-	See Note 6
61	90° backshell with female jackposts and nuts	H	9.5	-	-	See Note 5
62	90° backshell with female jackposts and nuts	J	15.2	-	-	See Note 7
63	Dust Cap (Male)	A	N/A	-	-	
64	Dust Cap (Female)	A	N/A	-	-	
65	Dust Cap (Male)	B	N/A	-	-	
66	Dust Cap (Female)	B	N/A	-	-	
67	Dust Cap (Male)	C	N/A	-	-	
68	Dust Cap (Female)	C	N/A	-	-	
69	Dust Cap (Male)	D	N/A	-	-	
70	Dust Cap (Female)	D	N/A	-	-	
71	Dust Cap (Male)	E	N/A	-	-	
72	Dust Cap (Female)	E	N/A	-	-	
73	Dust Cap (Male)	F	N/A	-	-	
74	Dust Cap (Female)	F	N/A	-	-	-
75	Dust Cap (Male)	G	N/A	-	-	
76	Dust Cap (Female)	G	N/A	-	-	
77	Dust Cap (Male)	H	N/A	-	-	
78	Dust Cap (Female)	H	N/A	-	-	
79	Dust Cap (Male)	J	N/A	-	-	
80	Dust Cap (Female)	J	N/A	-	-	

Type Variants	Descriptions	Applicable Shell Sizes	Weight Max (g)	Torque Values (Nm)		Remarks
				Min	Max	
81	Jackpost assembly for rear mounting on panel, Thickness Panel : 0.8 mm (screwlock, nut and lockwasher)	A, B, C, D, E, F, G, H	0.72	0.44 0.28 0.44	0.48 0.32 0.48	See Note 1 See Note 2 See Note 3
82	Jackpost assembly for rear mounting on panel, Thickness Panel : 1.2 mm (screwlock, nut and lockwasher)	A, B, C, D, E, F, G, H	0.71	0.44 0.28 0.44	0.48 0.32 0.48	See Note 1 See Note 2 See Note 3
83	Jackpost assembly for rear mounting on panel, Thickness Panel : 1.6 mm (screwlock, nut and lockwasher)	A, B, C, D, E, F, G, H	0.69	0.44 0.28 0.44	0.48 0.32 0.48	See Note 1 See Note 2 See Note 3
84	Jackpost assembly for rear mounting on panel, Thickness Panel : 2.4 mm (screwlock, nut and lockwasher)	A, B, C, D, E, F, G, H	0.66	0.44 0.28 0.44	0.48 0.32 0.48	See Note 1 See Note 2 See Note 3
85	Jackpost assembly for rear mounting on panel, Thickness Panel : 3.2mm (screwlock, nut and lockwasher)	A, B, C, D, E, F, G, H	0.62	0.44 0.28 0.44	0.48 0.32 0.48	See Note 1 See Note 2 See Note 3
86	Jackpost assembly for rear mounting on panel, Thickness Panel : 0.8 mm (screwlock, nut and lockwasher)	J	1.08	0.6 0.4 0.4	0.66 0.44 0.66	See Note 1 See Note 2 See Note 3
87	Jackpost assembly for rear mounting on panel, Thickness Panel : 1.2 mm (screwlock, nut and lockwasher)	J	1.05	0.6 0.4 0.4	0.66 0.44 0.66	See Note 1 See Note 2 See Note 3
88	Jackpost assembly for rear mounting on panel, Thickness Panel : 1.6 mm (screwlock, nut and lockwasher)	J	1.03	0.6 0.4 0.4	0.66 0.44 0.66	See Note 1 See Note 2 See Note 3
89	Jackpost assembly for rear mounting on panel, Thickness Panel : 2.4 mm (screwlock, nut and lockwasher)	J	0.99	0.6 0.4 0.4	0.66 0.44 0.66	See Note 1 See Note 2 See Note 3
90	Jackpost assembly for rear mounting on panel, Thickness Panel : 3.2mm (screwlock, nut and lockwasher)	J	0.95	0.6 0.4 0.4	0.66 0.44 0.66	See Note 1 See Note 2 See Note 3
91	Jackpost assembly for PCB mounting straight spills/PC tails, (screwlock, nut, lockwasher and spacer)	A, B, C, D, E, F, G, H	1.2	0.44 0.28 0.44	0.48 0.32 0.48	See Note 1 See Note 2 See Note 3
92	Jackpost assembly for PCB mounting straight spills/PC tails, (screwlock, nut, lockwasher and spacer)	J	2.3	0.6 0.4 0.6	0.66 0.48 0.66	See Note 1 See Note 2 See Note 3
93	Jackpost assembly for Connector with Rear Grommet Version, (screwlock, nut and lockwasher)	A, B, C, D, E, F, G, H	0.9	0.44 0.28 0.44	0.48 0.32 0.48	See Note 1 See Note 2 See Note 3
94	Jackpost assembly for Connector with Rear Grommet Version, (screwlock, nut and lockwasher)	J	1.6	0.6 0.4 0.6	0.66 0.48 0.66	See Note 1 See Note 2 See Note 3

Type Variants	Descriptions	Applicable Shell Sizes	Weight Max (g)	Torque Values (Nm)		Remarks
				Min	Max	
95	Jackpost assembly for Savers Connector (screwlock, and retaining ring)	A, B, C, D, E, F, G, H	0.9	0.44 0.28 0.44	0.48 0.32 0.48	See Note 1 See Note 2 See Note 3
96	Jackpost assembly for Savers Connector (screwlock, and retaining ring)	J	1.8	0.6 0.4 0.6	0.66 0.48 0.66	See Note 1 See Note 2 See Note 3
97	Bracket for mounting on PCB with 90° bent contacts	A, B, C, D, E, F	0.85	0.44	0.48	
98	Bracket for mounting on PCB with 90° bent contacts	G, H	1	0.44	0.48	
99	Bracket for mounting on PCB with 90° bent contacts	J	2.45	0.6	0.66	

NOTES:

1. These torque values apply to the male side of the jackpost.
2. These torque values apply to the female side of the jackpost.
3. These torque values apply to the nut.
4. Weight of backshell without male jackscrews and clips. The maximum weight of one clip and one screw is 1.12g.
5. Weight of backshell without female jackposts and nuts. The maximum weight of jackpost and one nut is 0.65g.
6. Weight of backshell without male jackscrews and clips. The maximum weight of one clip and one screw is 1.75g.
7. Weight of backshell without female jackposts and nuts. The maximum weight of one jackpost and one nut is 0.95g.

TABLE 1(b) - MAXIMUM RATINGS

No.	Characteristics	Symbol	Maximum Ratings	Unit
1	Operating Temperature Range	T _{op}	-55 to +125	°C
2	Storage Temperature Range	T _{stg}	-65 to +125	°C

FIGURE 1 – PARAMETER DERATING INFORMATION

Not applicable.

FIGURE 2 - PHYSICAL DIMENSIONS

FIGURE 2(a) - VARIANTS 01 AND 02

Allen Head Jackscrew

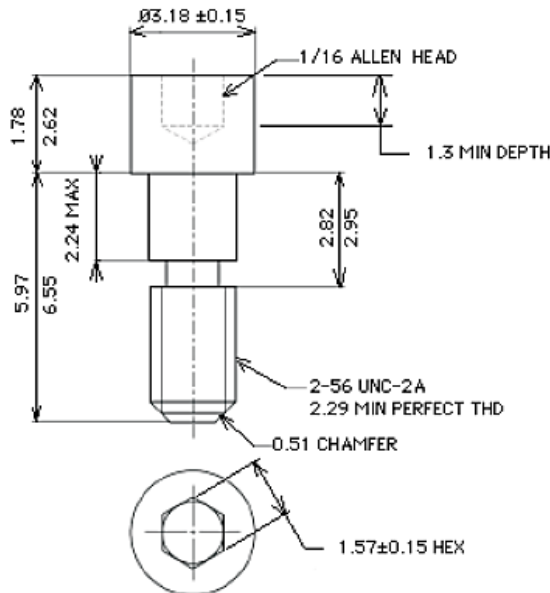

Slot Head Jackscrew

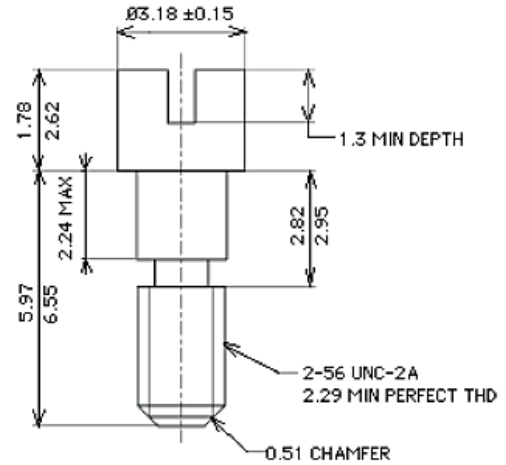

Retaining Ring

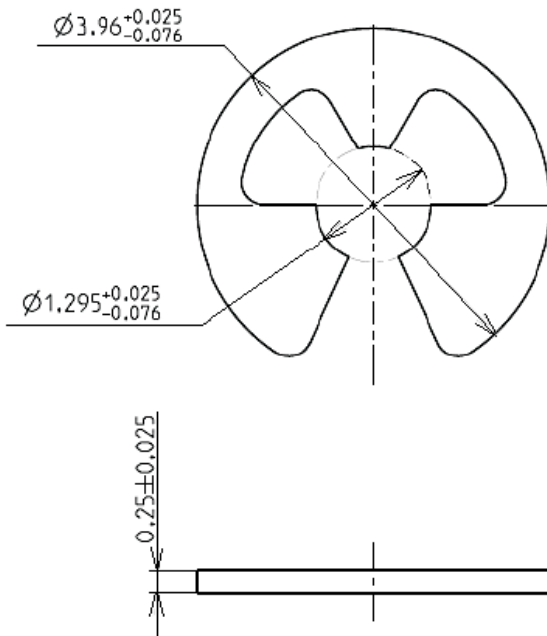

Retaining Ring (when sprung into groove)

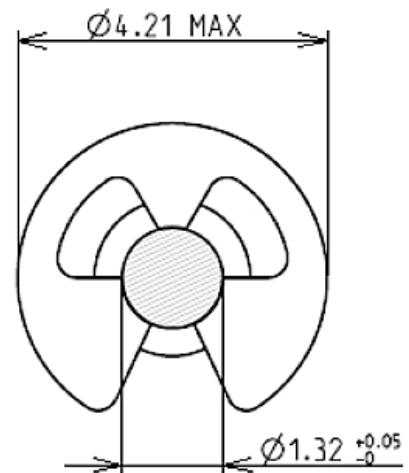

NOTES:

1. All dimensions are in millimetres.

FIGURE 2(b) - VARIANT 03

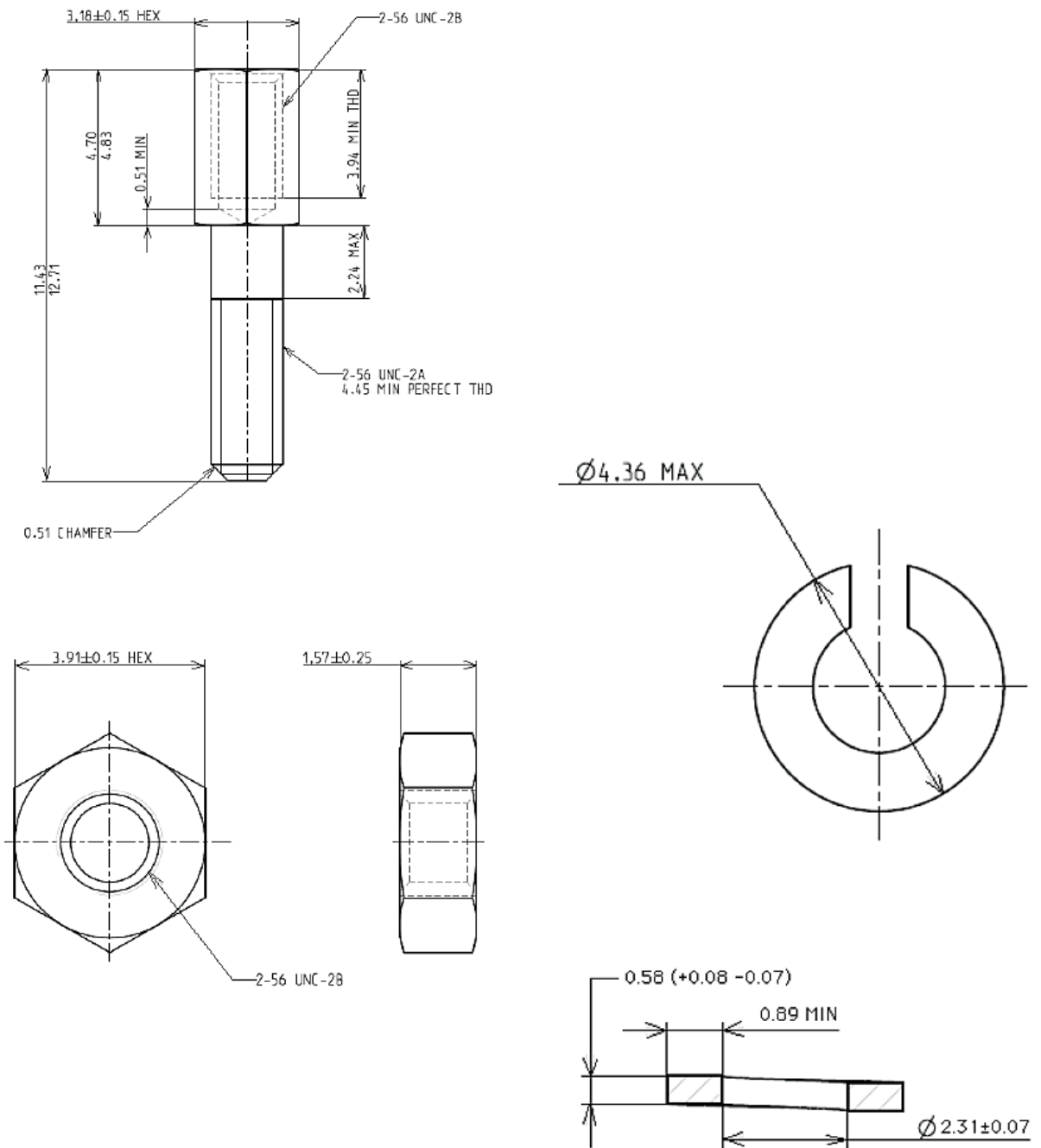

NOTES:

1. All dimensions are in millimetres.

FIGURE 2(c) - VARIANTS 04 AND 05

Allen Head Jackscrew

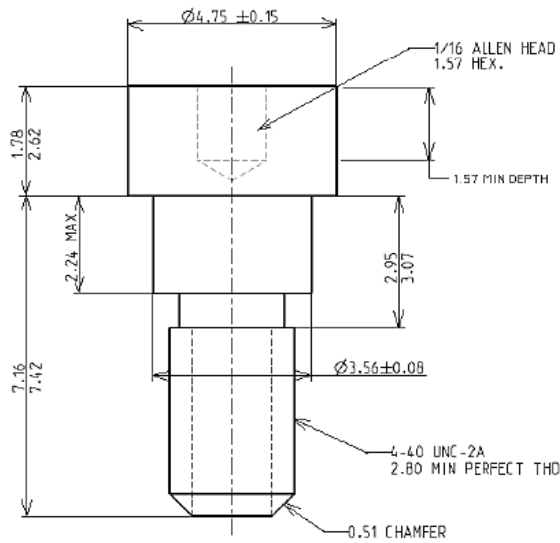

Slot Head Jackscrew

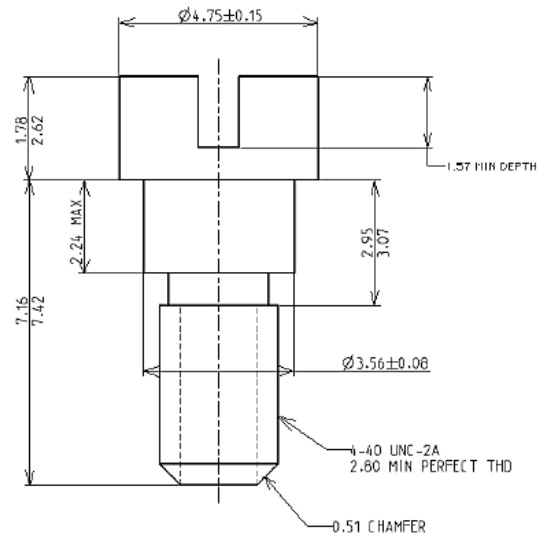

Retaining Ring

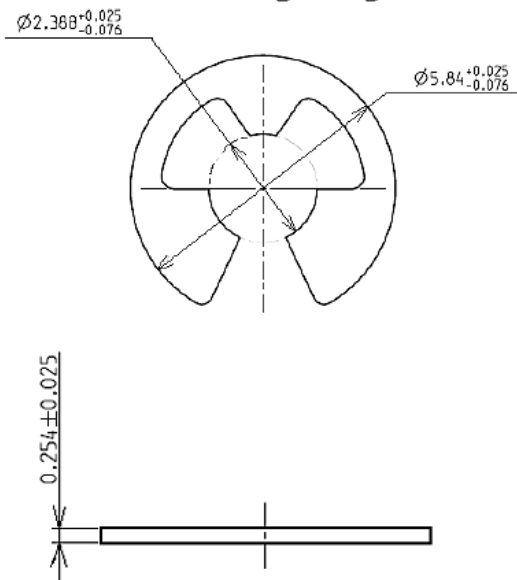

Retaining Ring (when sprung into groove)

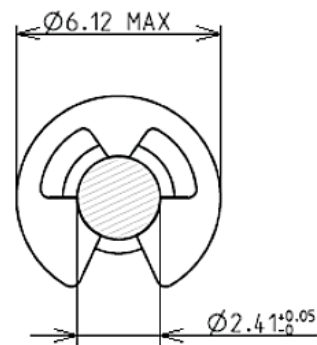

NOTES:

1. All dimensions are in millimetres.

FIGURE 2(d) - VARIANT 06

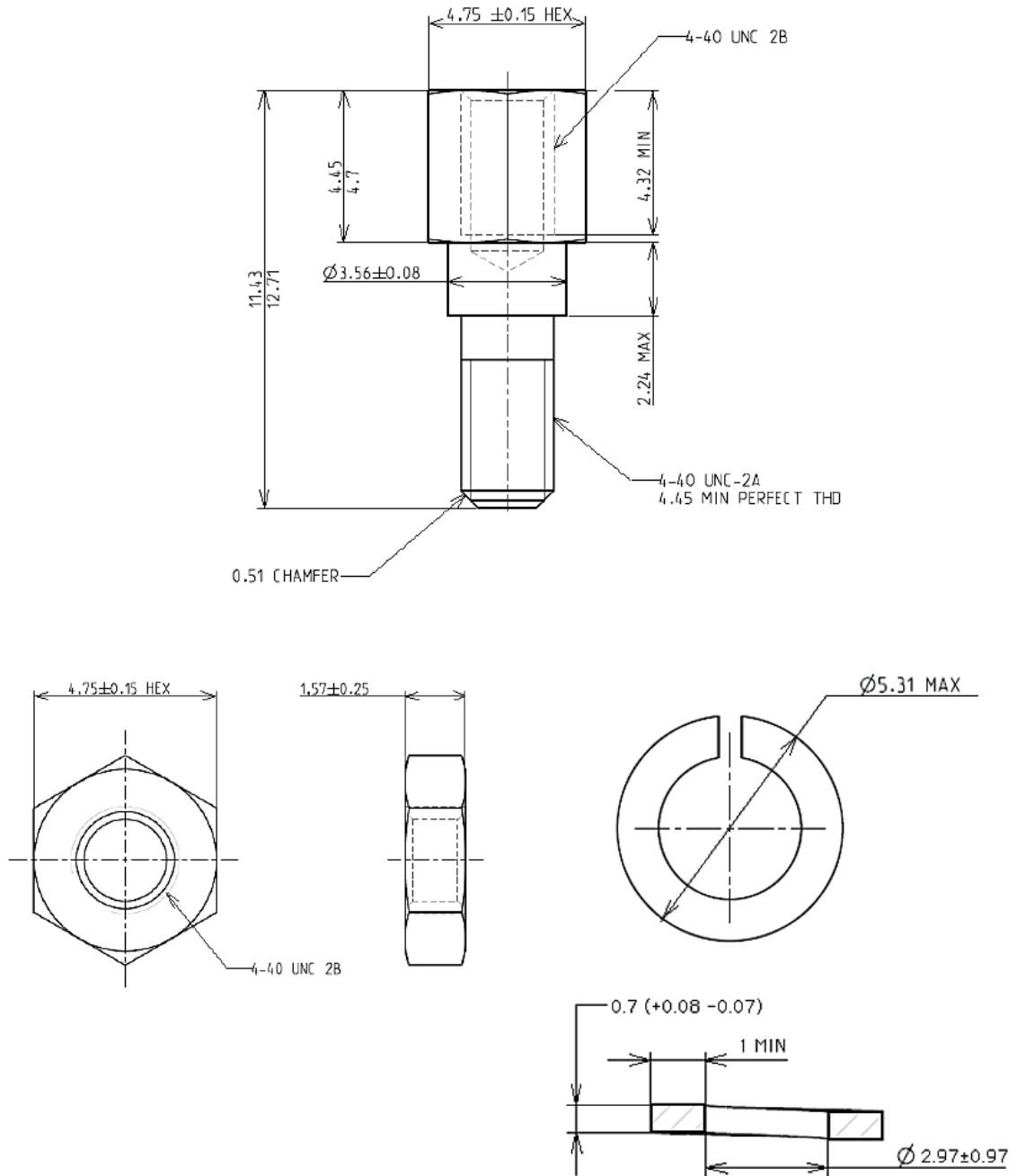

NOTES:

1. All dimensions are in millimetres.

FIGURE 2(e) - VARIANT 07

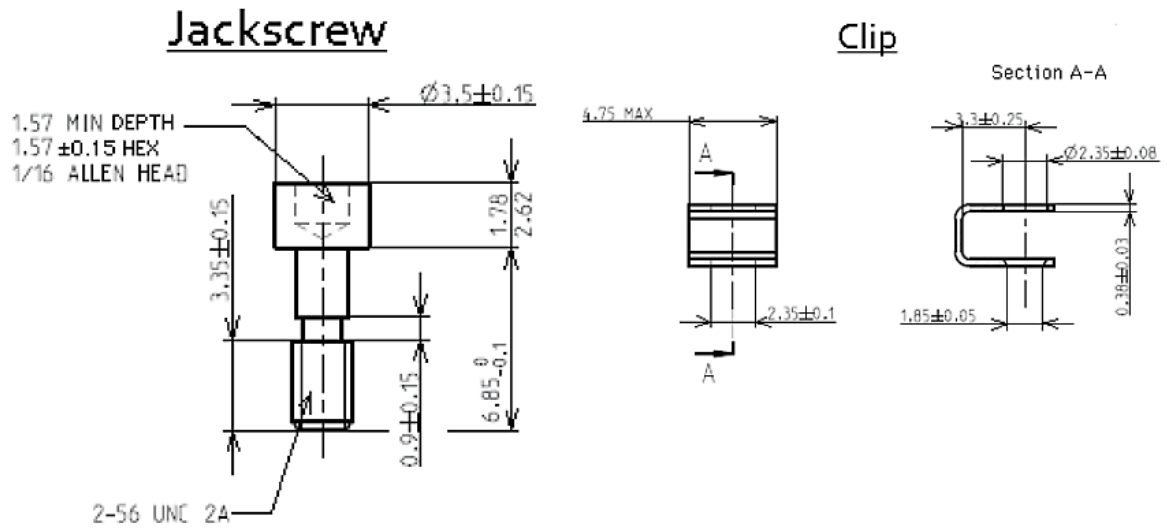

NOTES:

1. All dimensions are in millimetres.

FIGURE 2(f) - VARIANT 08

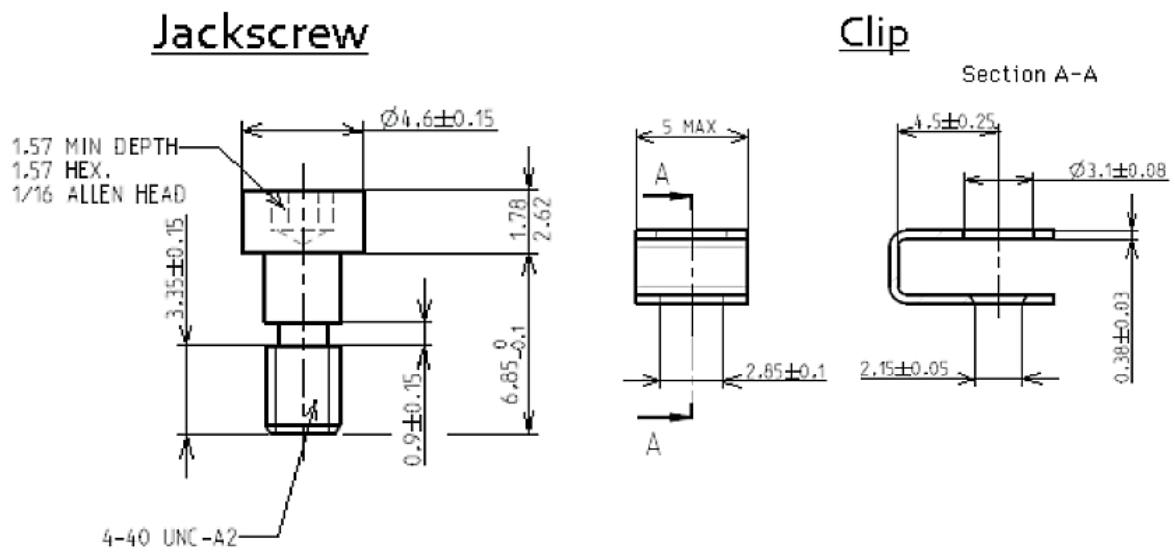

NOTES:

1. All dimensions are in millimetres.

FIGURE 2(g) - VARIANTS 09 TO 22

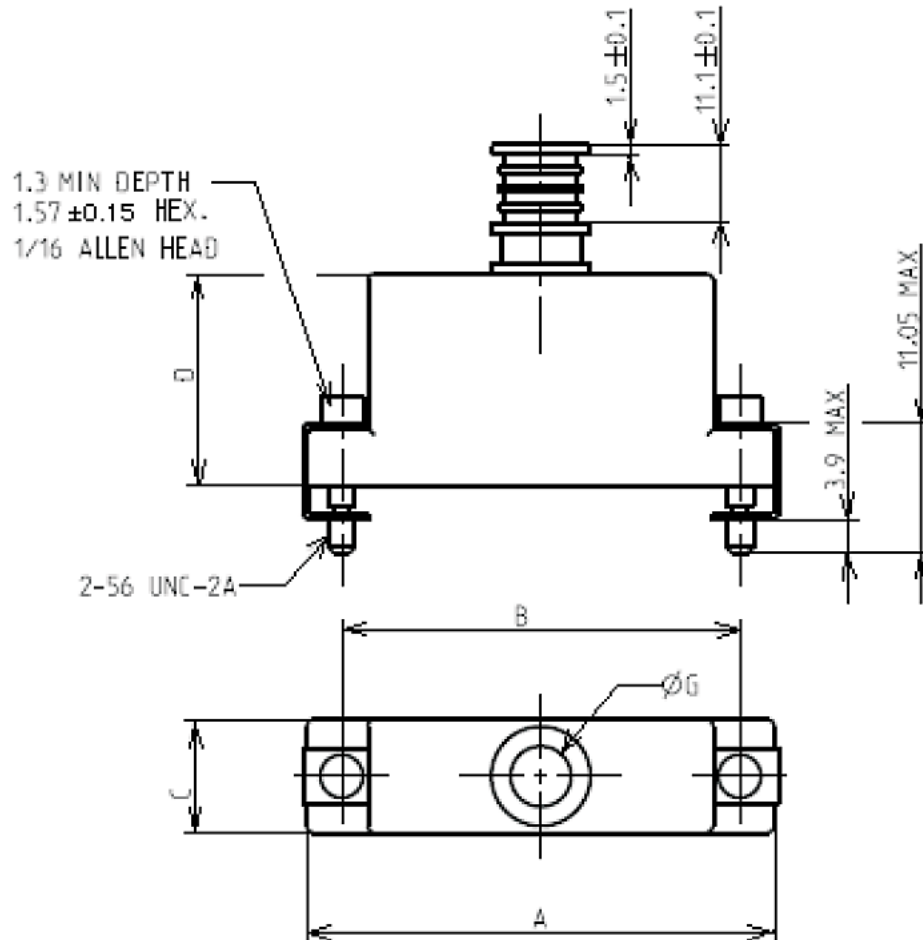

Variant Numbers		A		B		C		D Max	ØG	
Male Jackscrew	Female Jackpost (Note 2)	Min	Max	Min	Max	Min	Max		Min	Max
09	16	19.55	19.85	14.22	14.48	8.85	9.15	10	3.05	3.35
10	17	23.25	23.55	18.03	18.29	8.85	9.15	12	3.05	3.35
11	18	27.15	27.45	21.84	22.1	8.85	9.15	14	3.05	3.35
12	19	29.7	30	24.38	24.64	8.85	9.15	16	4.65	4.95
13	20	33.55	33.85	28.19	28.45	8.85	9.15	17	4.65	4.95
14	21	37.35	37.65	32	32.26	8.85	9.15	18	4.65	4.95
15	22	35.95	36.25	30.73	30.99	9.85	10.15	19	6.25	6.55

NOTES:

1. All dimensions are in millimetres.
2. See Figure 2(i) for female jackpost dimensions.

FIGURE 2(h) - VARIANTS 23 TO 36

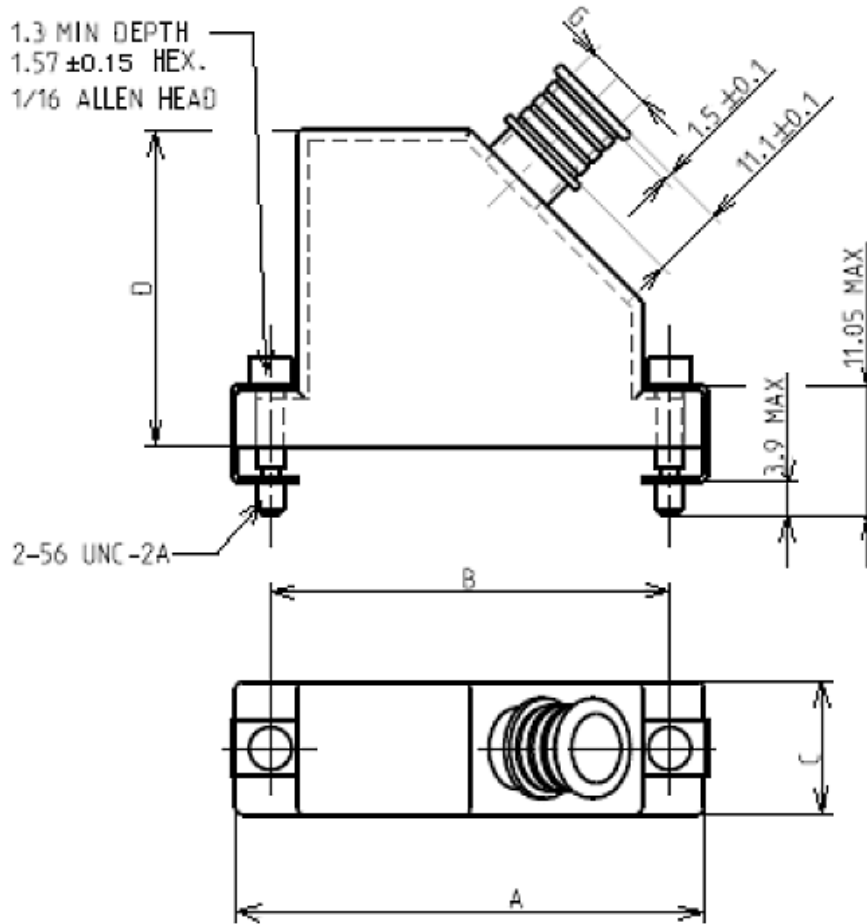

Variant Numbers		A		B		C		D Max	ØG	
Male Jackscrew	Female Jackpost (Note 2)	Min	Max	Min	Max	Min	Max		Min	Max
23	30	19.55	19.85	14.22	14.48	8.85	9.15	21	3.05	3.35
24	31	23.25	23.55	18.03	18.29	8.85	9.15	23	3.05	3.35
25	32	27.15	27.45	21.84	22.1	8.85	9.15	25	3.05	3.35
26	33	29.7	30	24.38	24.64	8.85	9.15	27	4.65	4.95
27	34	33.55	33.85	28.19	28.45	8.85	9.15	28	4.65	4.95
28	35	37.35	37.65	32	32.26	8.85	9.15	29	4.65	4.95
29	36	35.95	36.25	30.73	30.99	9.85	10.15	30	6.25	6.55

NOTES:

1. All dimensions are in millimetres.
2. See Figure 2(i) for female jackpost dimensions.

FIGURE 2(i) - VARIANTS 37 TO 50

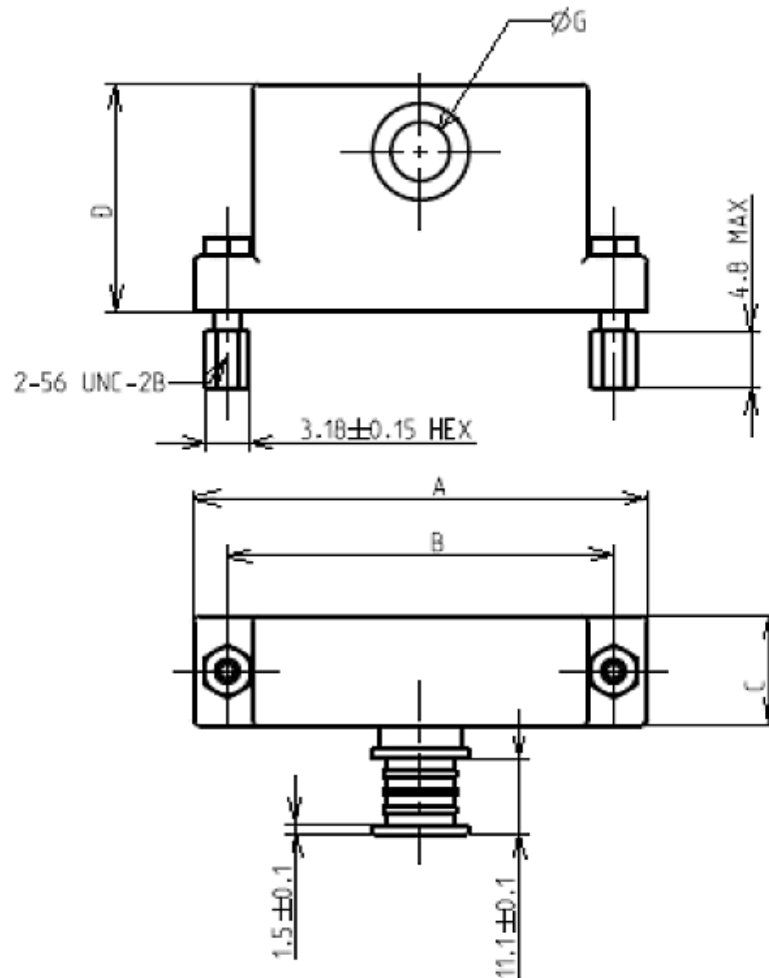

Variant Numbers		A		B		C		D Max	ØG	
Male Jackscrew (Note 2)	Female Jackpost	Min	Max	Min	Max	Min	Max		Min	Max
37	44	19.55	19.85	14.22	14.48	8.85	9.15	15	3.05	3.35
38	45	23.25	23.55	18.03	18.29	8.85	9.15	16.5	3.05	3.35
39	46	27.15	27.45	21.84	22.1	8.85	9.15	18	3.05	3.35
40	47	29.7	30	24.38	24.64	8.85	9.15	20	4.65	4.95
41	48	33.55	33.85	28.19	28.45	8.85	9.15	21	4.65	4.95
42	49	37.35	37.65	32	32.26	8.85	9.15	22	4.65	4.95
43	50	35.95	36.25	30.73	30.99	9.85	10.15	23	6.25	6.55

NOTES:

1. All dimensions are in millimetres.
2. See Figure 2(g) for male jackscrew dimensions.

FIGURE 2(j) - VARIANTS 51 TO 54

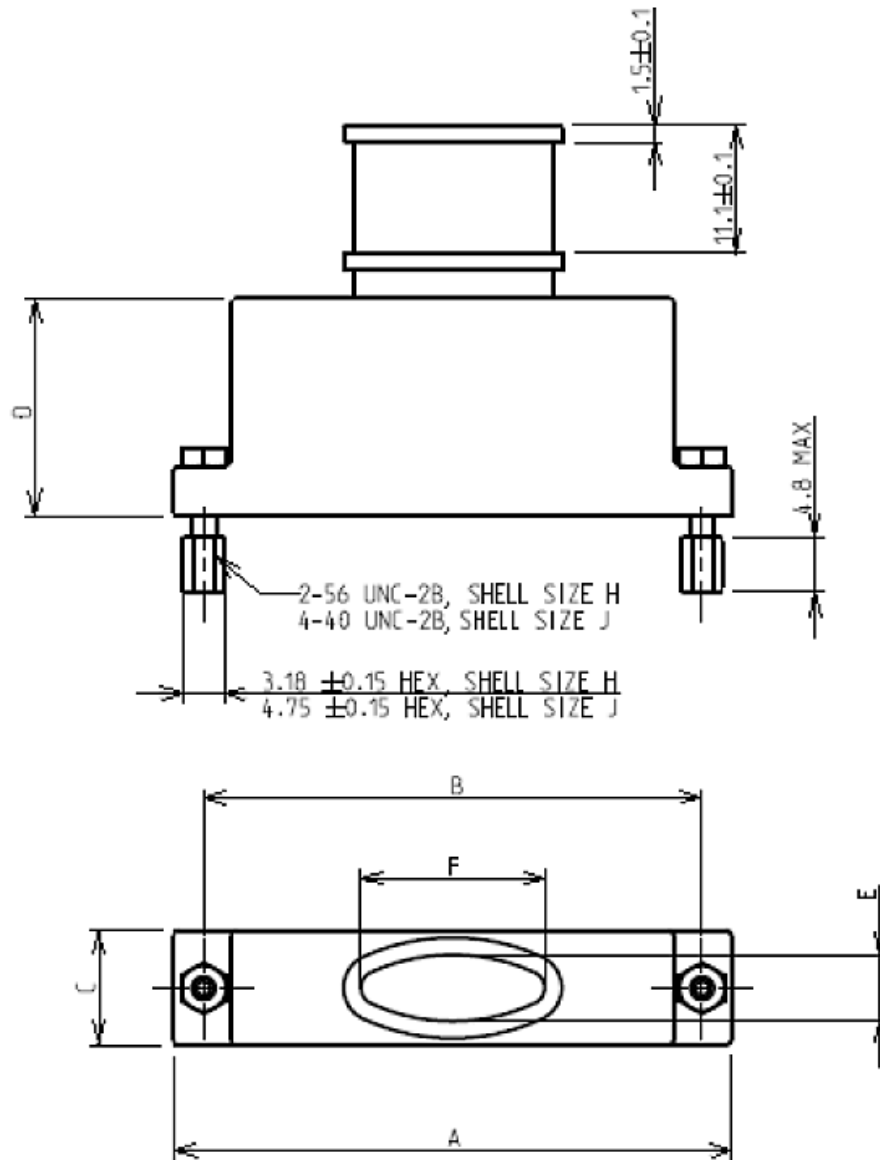

Variant Numbers		A		B		C		D Max	E		F	
Male Jackscrew (Note 2)	Female Jackpost	Min	Max	Min	Max	Min	Max		Min	Max	Min	Max
51	53	48.7	49	43.23	43.49	9.85	10.15	19	5.65	5.95	10.65	10.95
52	54	62.65	62.95	54.72	54.98	12.85	13.15	21	6.65	6.95	23.35	23.65

NOTES:

1. All dimensions are in millimetres.
2. See Figure 2(k) for male jackscrew dimensions.

FIGURE 2(k) - VARIANTS 55 TO 58

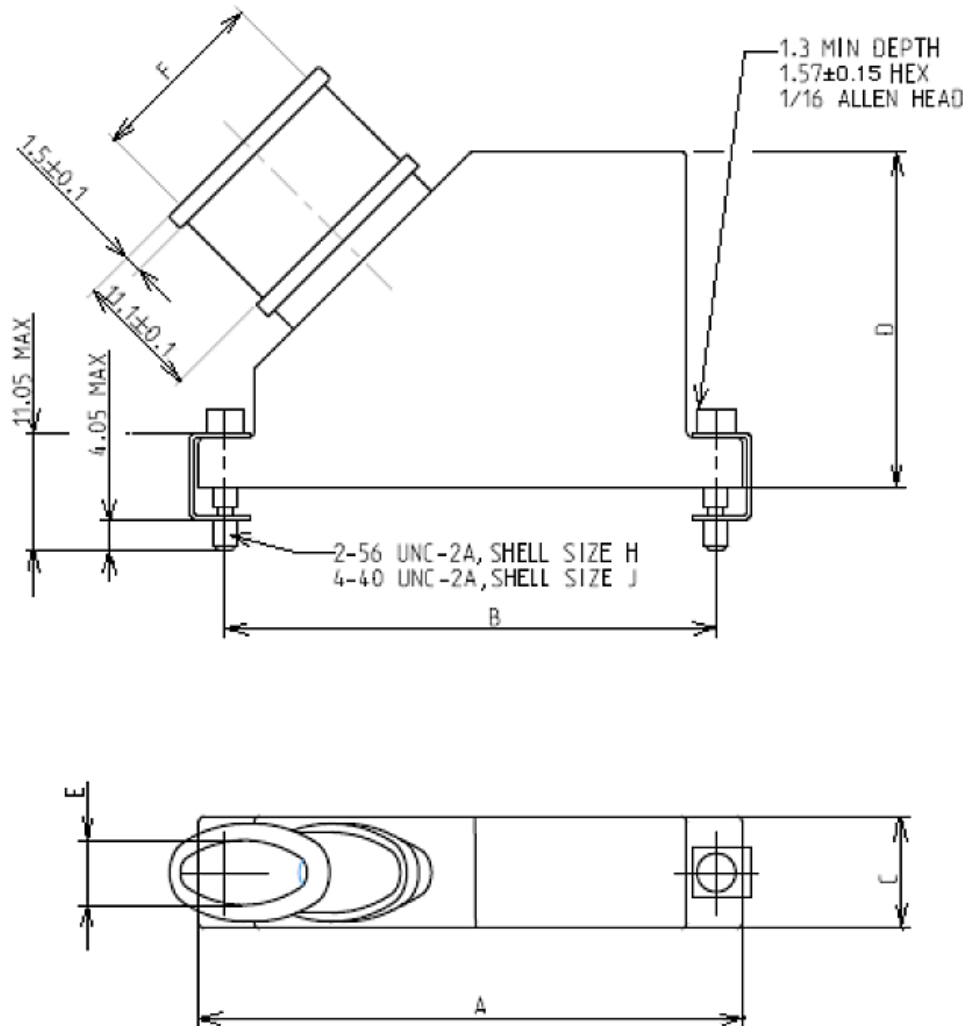

Variant Numbers		A		B		C		D Max	E		F	
Male Jackscrew	Female Jackpost (Note 2)	Min	Max	Min	Max	Min	Max		Min	Max	Min	Max
55	57	48.7	49	43.23	43.49	9.85	10.15	30	5.65	5.95	10.65	10.95
56	58	62.65	62.95	54.72	54.98	12.85	13.15	38	6.65	6.95	23.35	23.65

NOTES:

1. All dimensions are in millimetres.
2. See Figure 2(j) for female jackpost dimensions.

FIGURE 2(l) - VARIANTS 59 TO 62

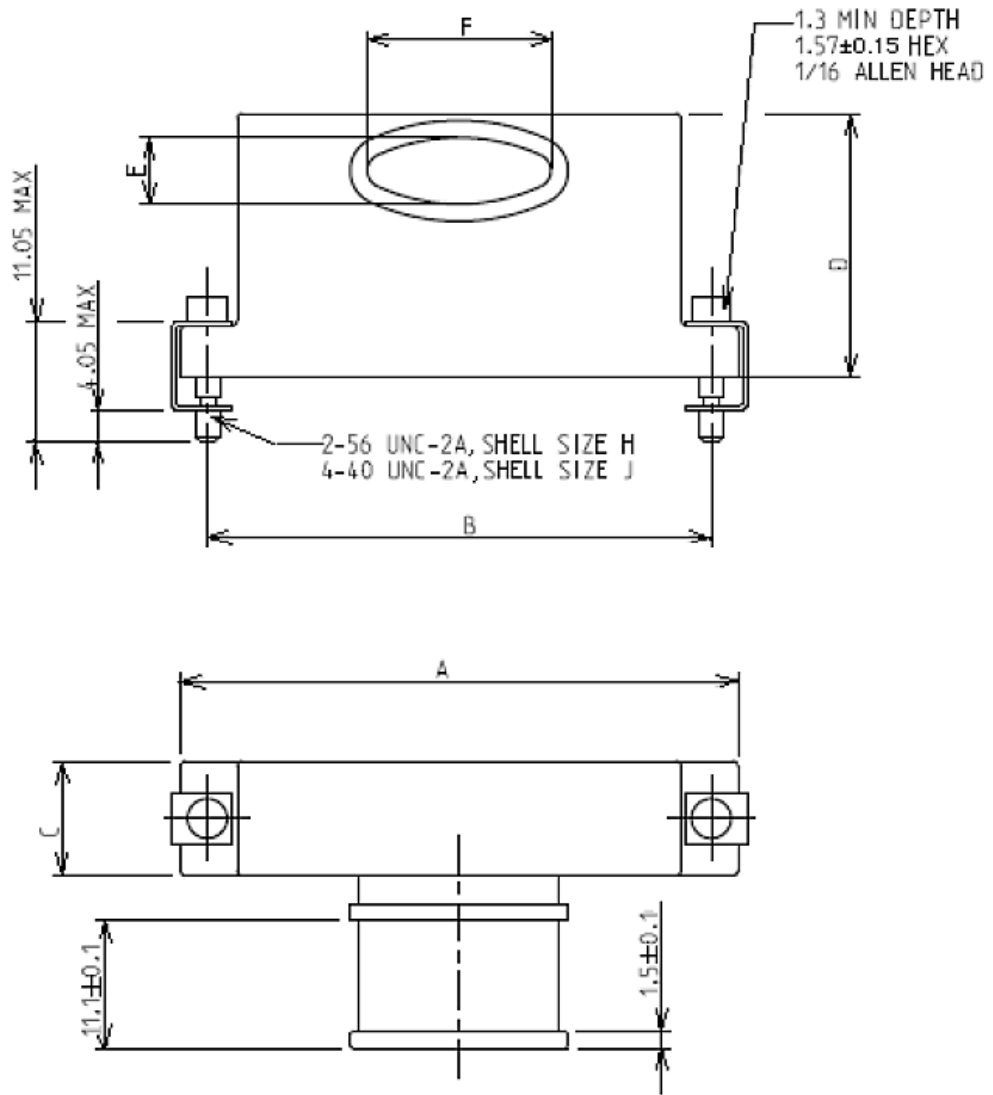

Variant Numbers		A		B		C		D Max	E		F	
Male Jackscrew	Female Jackpost (Note 2)	Min	Max	Min	Max	Min	Max		Min	Max	Min	Max
59	61	48.7	49	43.23	43.49	9.85	10.15	23	5.65	5.95	10.65	10.95
60	62	62.65	62.95	54.72	54.98	12.85	13.15	25	6.65	6.95	23.35	23.65

NOTES:

1. All dimensions are in millimetres.
2. See Figure 2(j) for female jackpost dimensions.

FIGURE 2(m) - VARIANTS 63 TO 80

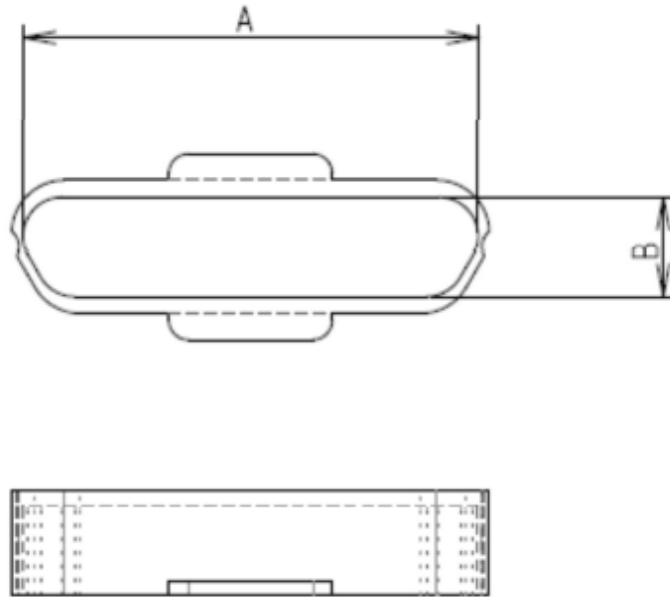

Variants	63	64	65	66	67	68	69	70	71	72	73	74	75	76	77	78	79	80
A ± 0.25	8	9.8	11.8	13.6	15.6	17.4	18.2	19.9	22	23.7	25.8	27.6	24.5	26.3	37.9	38.8	45.2	46.8
B ± 0.25	4.7	6.4	4.7	6.4	4.7	6.4	4.7	6.4	4.7	6.4	4.7	6.4	5.8	7.4	5.8	7.4	9.35	11

NOTES:

1. All dimensions are in millimetres.

FIGURE 2(n) - VARIANTS 81 TO 85

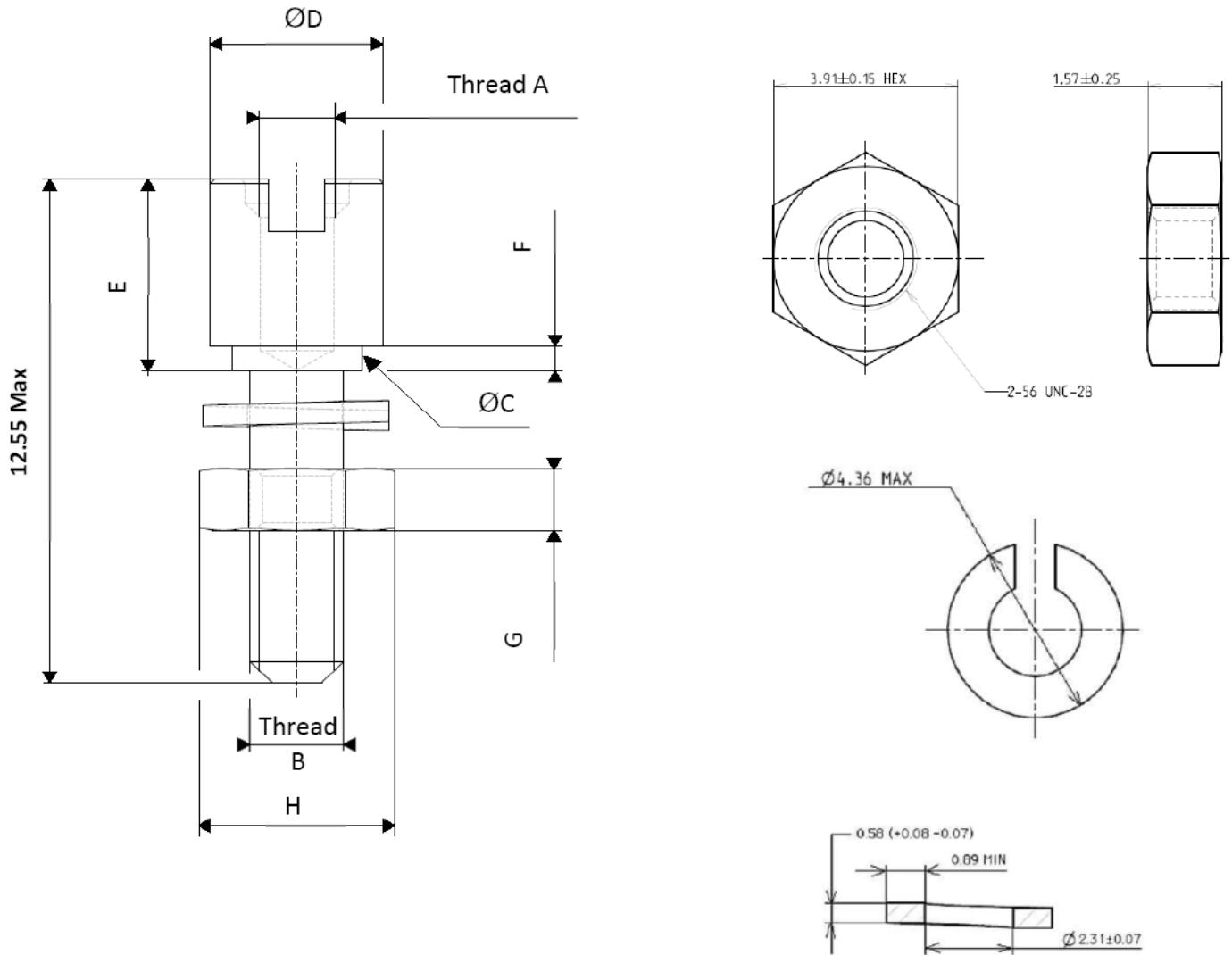

Variant	A	B	ØC Max	ØD Max	E	F Max	G Max	H Max
81	2-56 UNC-2B	2-56 UNC-2A	3	4.1	4.7/4.83	0.615	1.82	4.06
82	2-56 UNC-2B	2-56 UNC-2A	3	4.1	4.7/4.83	1.09	1.82	4.06
83	2-56 UNC-2B	2-56 UNC-2A	3	4.1	4.7/4.83	1.45	1.82	4.06
84	2-56 UNC-2B	2-56 UNC-2A	3	4.1	4.7/4.83	2.23	1.82	4.06
85	2-56 UNC-2B	2-56 UNC-2A	3	4.1	4.7/4.83	3.05	1.82	4.06

NOTES:

1. All dimensions are in millimetres.

FIGURE 2(o) - VARIANTS 86 TO 90

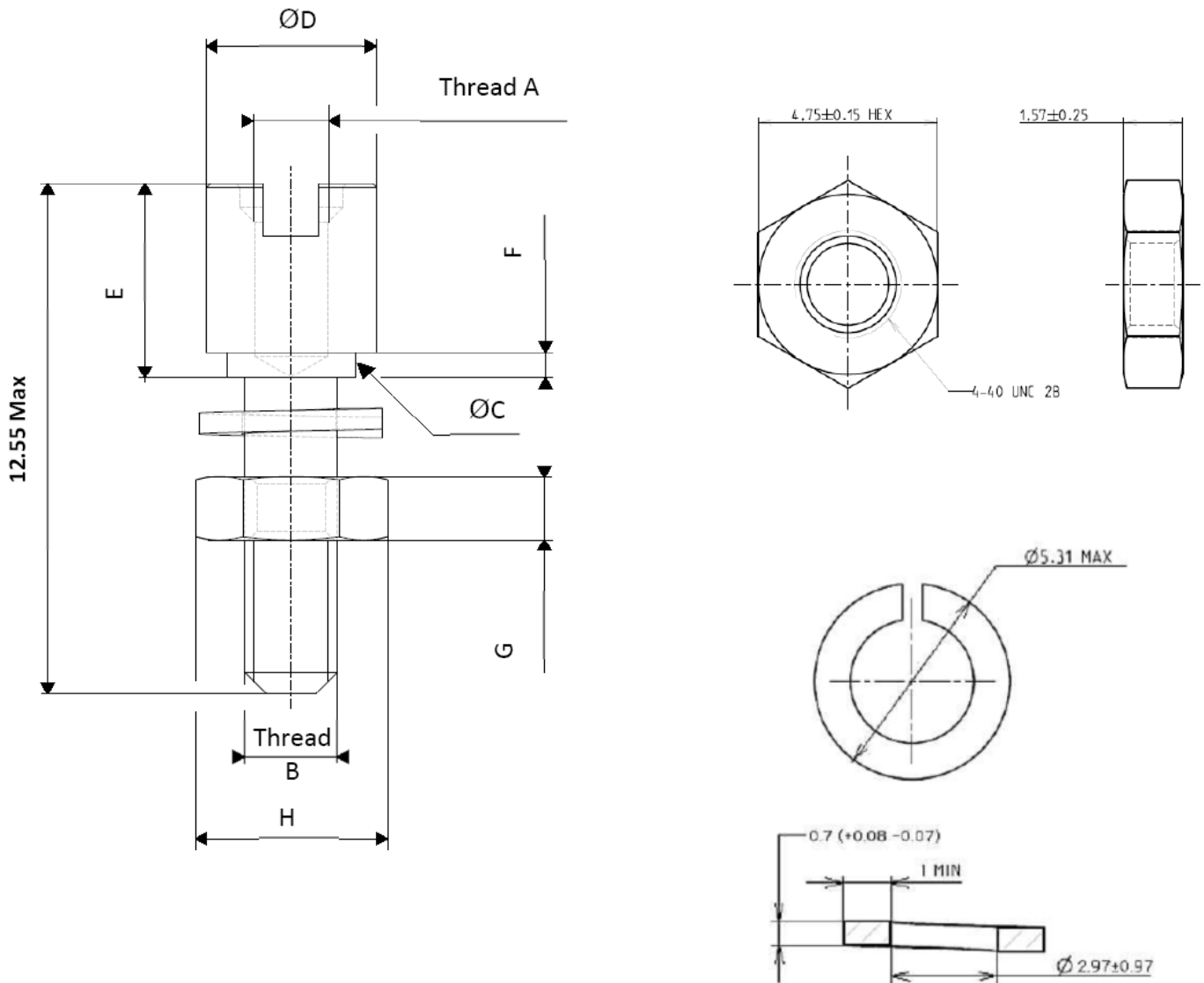

Variant	A	B	ØC Max	ØD Max	E	F Max	G Max	H Max
86	4-40 UNC-2B	4-40 UNC-2A	3.6	4.71	4.45/4.7	0.615	1.82	4.9
87	4-40 UNC-2B	4-40 UNC-2A	3.6	4.71	4.45/4.7	1.09	1.82	4.9
88	4-40 UNC-2B	4-40 UNC-2A	3.6	4.71	4.45/4.7	1.45	1.82	4.9
89	4-40 UNC-2B	4-40 UNC-2A	3.6	4.71	4.45/4.7	2.23	1.82	4.9
90	4-40 UNC-2B	4-40 UNC-2A	3.6	4.71	4.45/4.7	3.05	1.82	4.9

NOTES:

1. All dimensions are in millimetres.

FIGURE 2(p) - VARIANTS 91

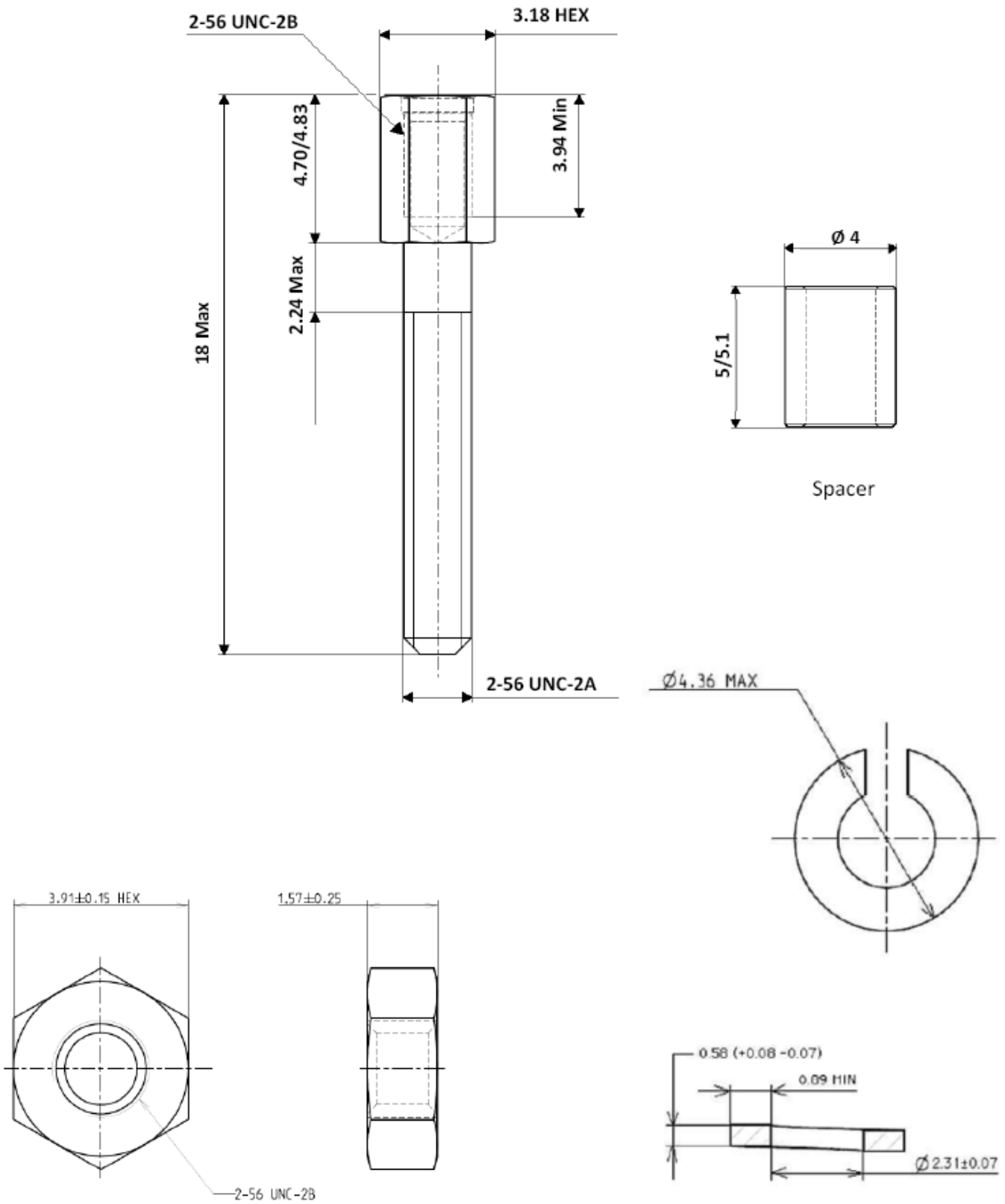

NOTES:

1. All dimensions are in millimetres

FIGURE 2(q) - VARIANT 92

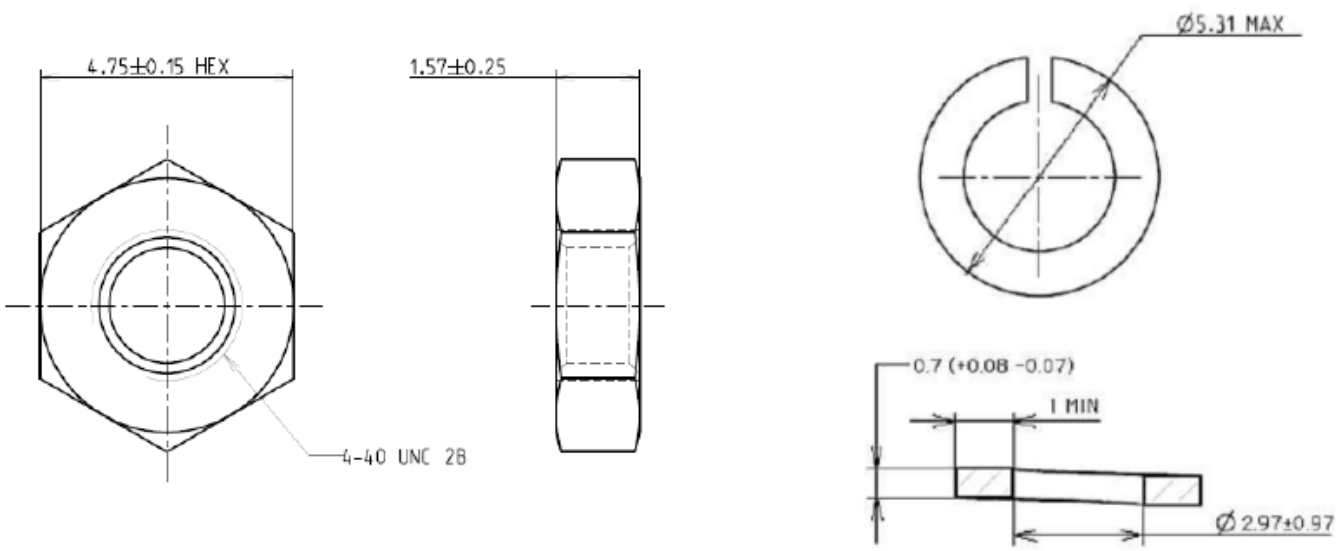
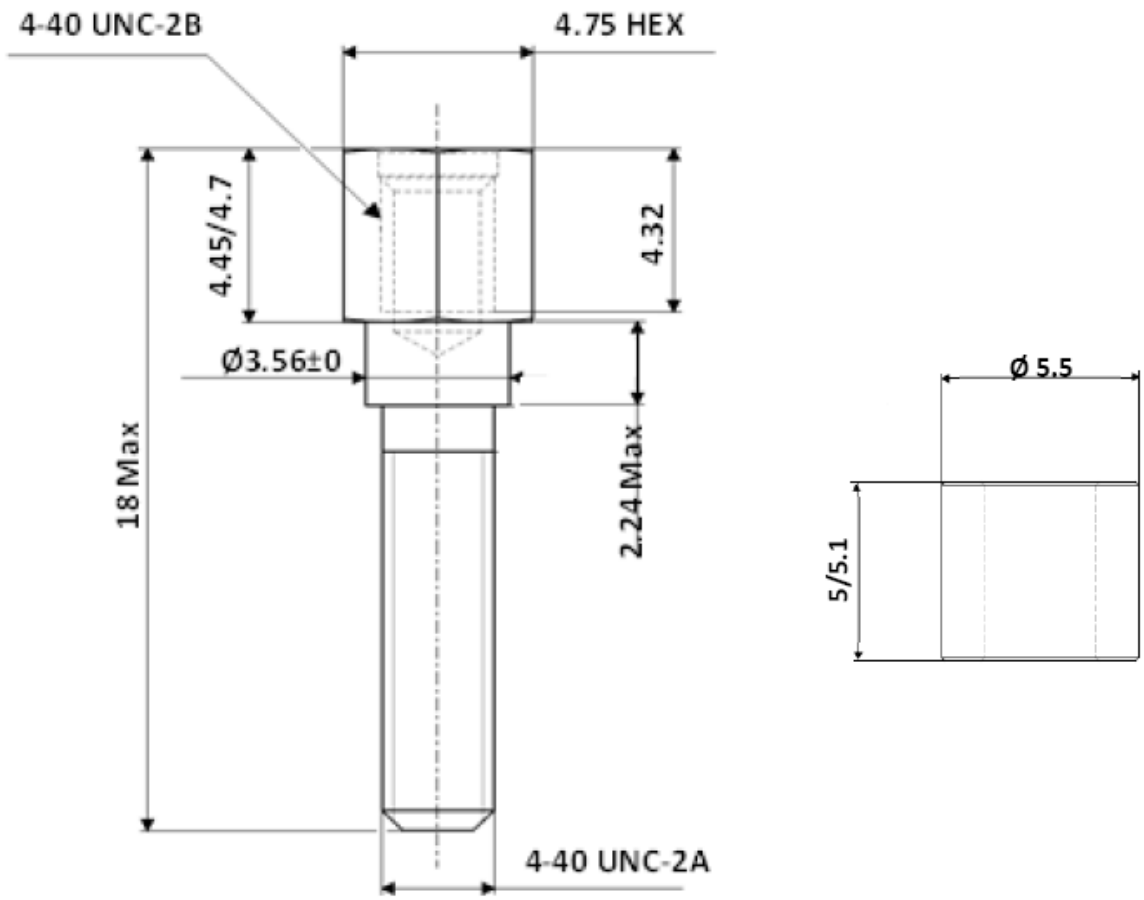

NOTES:

1. All dimensions are in millimetres

FIGURE 2(r) - VARIANTS 93 TO 94

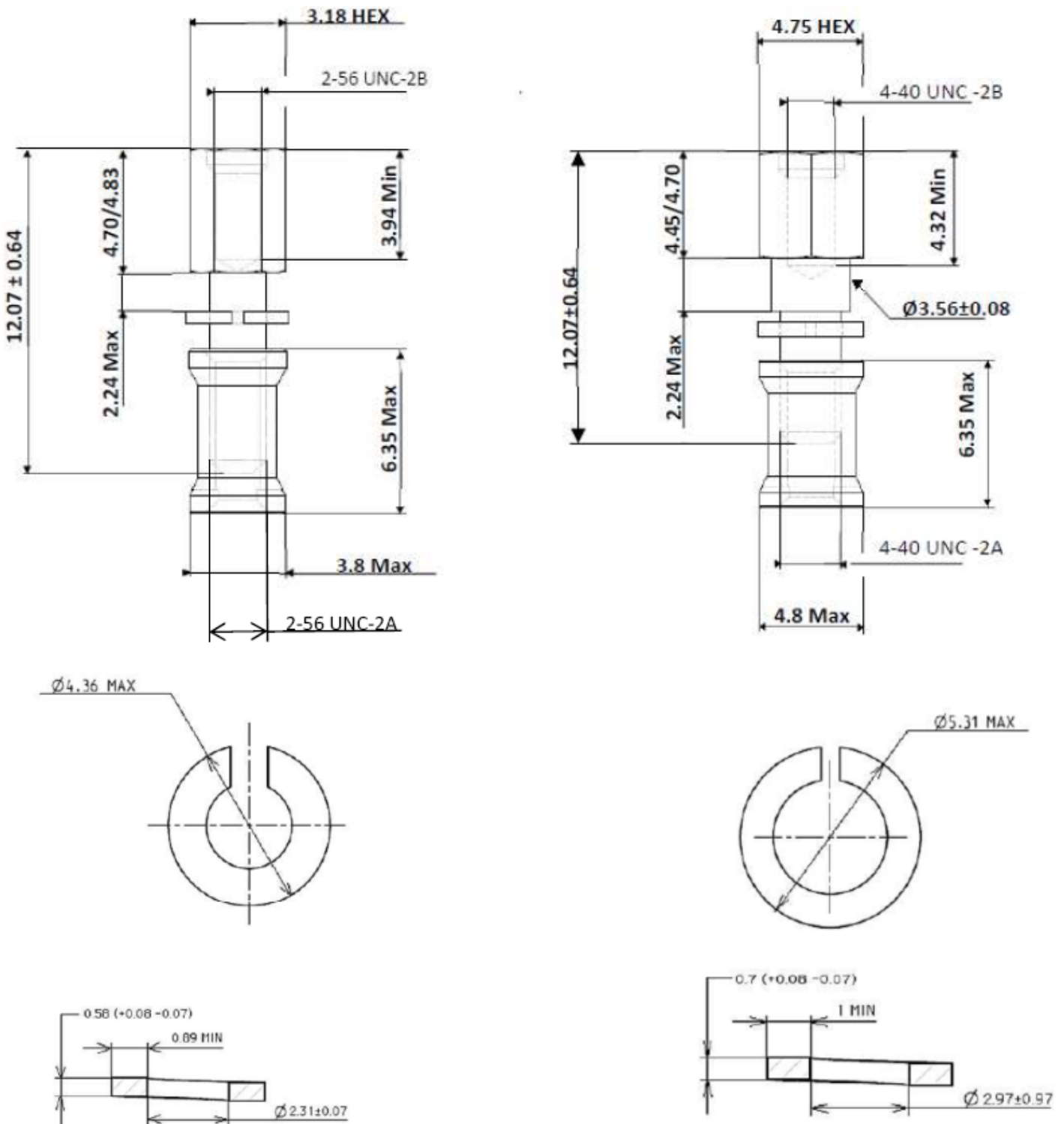

NOTES:

1. All dimensions are in millimetres

FIGURE 2(s) - VARIANTS 95 TO 96

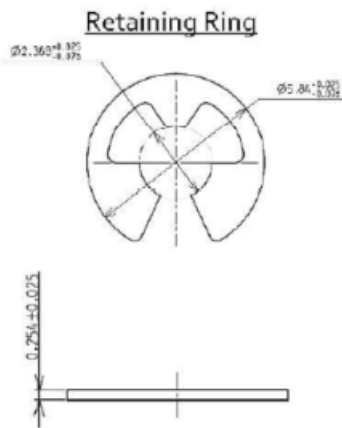
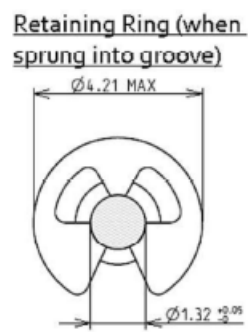
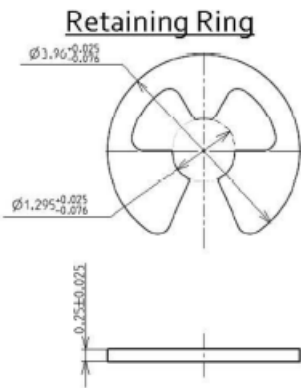
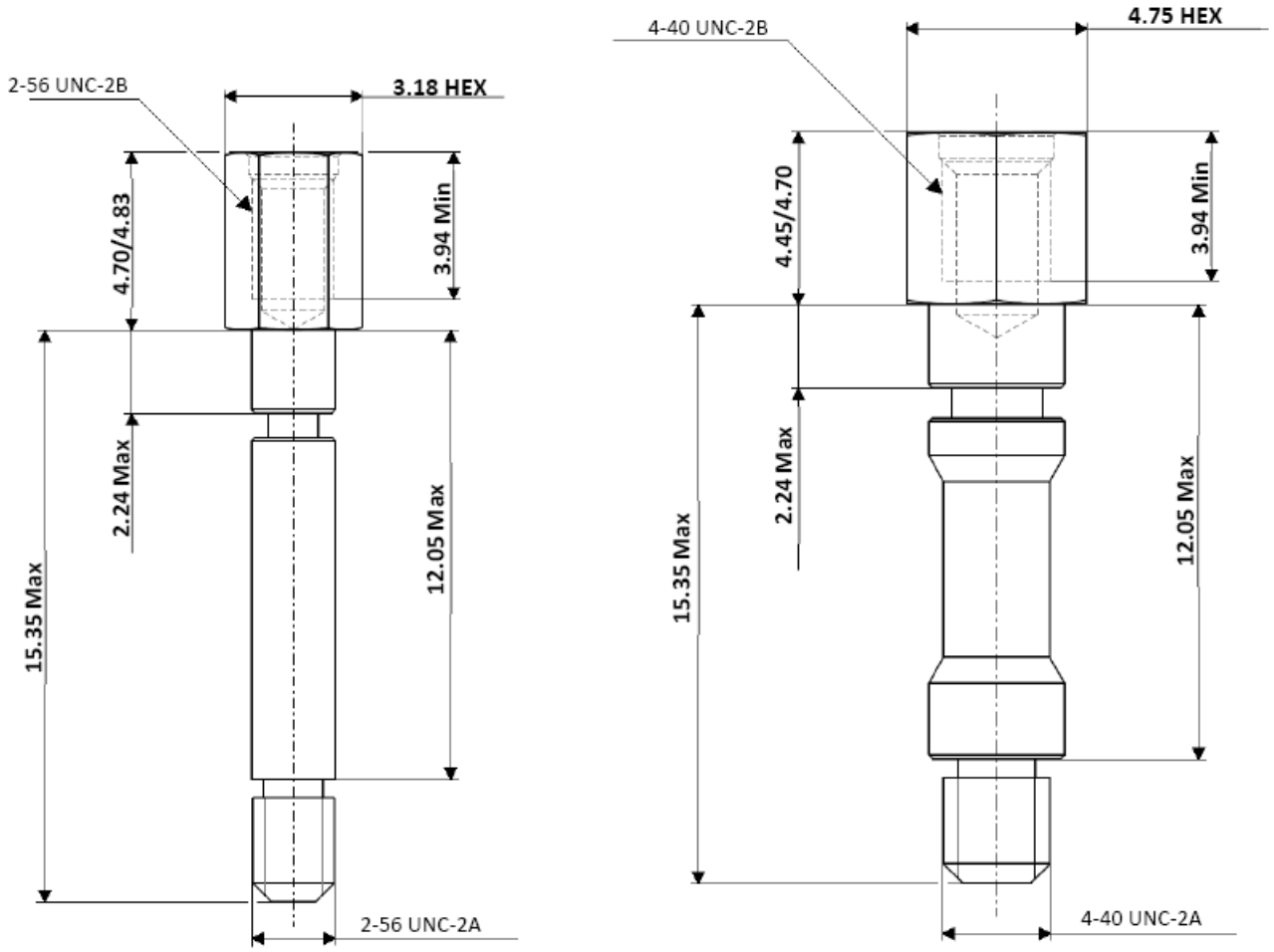

NOTES:

1. All dimensions are in millimetres

FIGURE 2(t) - VARIANTS 97 TO 99

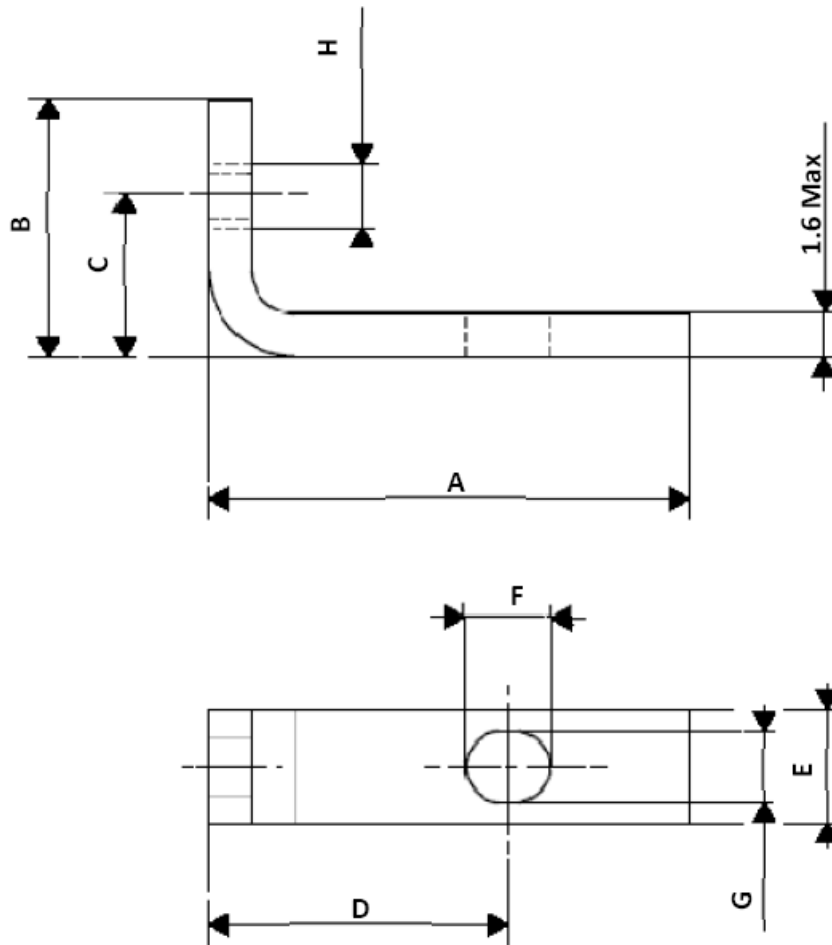

Variant	A Max	B Max	C ± 0.10	D ± 0.10	E ± 0.10	F Max	G	H
97	14.1	8.6	5	9.17	4	3.15	2.44 ± 0.1	2-56 UNC-2B
98	16.9	9.1	5.6	10.44	4	3.15	2.44 ± 0.1	2-56 UNC-2B
99	23.1	13.1	7.35	13.13	6.5	4.2	3.15 ± 0.15	4-40 UNC-2B

NOTES:

1. All dimensions are in millimetres

4 REQUIREMENTS

4.1 GENERAL

The complete requirements for procurement of the accessories specified herein are stated in this specification and ESCC Generic Specification No. 3401. Deviations from the Generic Specification, applicable to this specification only, are listed in Para. 4.2.

Deviations from the applicable Generic Specification and this Detail Specification, formally agreed with specific Manufacturers on the basis that the alternative requirements are equivalent to the ESCC requirements and do not affect the components' reliability, are listed in the appendices attached to this specification.

4.2 DEVIATIONS FROM GENERIC SPECIFICATION

4.2.1 Deviations from Special In-Process Controls

None.

4.2.2 Deviations from Final Production Tests (Chart II)

Only the following tests shall be performed:

- (a) Para. 9.6, Dimension Check.
- (b) Para. 9.7, External Visual Inspection. The magnification shall be X3.

4.2.3 Deviations from Burn-in and Electrical Measurements (Chart III)

Chart III is not applicable.

4.2.4 Deviations from Qualification, Environmental and Endurance Tests (Chart IV)

Chart IV is not applicable.

4.2.5 Deviations from Lot Acceptance Tests (Chart V)

Chart V is not applicable.

4.3 MECHANICAL REQUIREMENTS

4.3.1 Dimension Check

The dimensions of the accessories specified herein shall be verified in accordance with the requirements set out in Para. 9.6 of ESCC Generic Specification No. 3401 and Para. 4.2.2 of this specification; they shall conform to those shown in Figure 2.

4.3.2 Weight

The maximum weight of the accessories specified herein shall be as specified in Figure 2.

4.3.3 Torque Value

The torque value to be used for tightening the screws of the accessories specified herein shall be as specified in Table 1(a).

4.4 MATERIALS AND FINISHES

The materials and finishes shall be as specified herein. Where a definite material is not specified, a material which will enable the components specified herein to meet the performance requirements of this specification shall be used. Acceptance or approval of any constituent material does not guarantee acceptance of the finished product.

4.4.1 Screw Lock Assemblies (Jackpost, Jackscrew)

These shall be made of passivated stainless steel except for the female jackposts for backshell shell size J: The material shall be brass and the finish shall be electroless nickel with a minimum thickness of 10µm.

4.4.2 Clips

These shall be made of passivated stainless steel.

4.4.3 Backshells

The material shall be aluminium alloy and the finish shall be 0.7µm minimum of gold over a copper or electroless nickel base layer with a minimum thickness of 10µm.

4.4.4 Dust Caps

Material: Red, Black or White polypropylene or polyethylene.

4.5 MARKING

4.5.1 General

The marking of components delivered to this specification shall be in accordance with the requirements of ESCC Basic Specification No. 21700 and the following paragraphs. Each component shall be marked in respect of:

- (a) The ESCC Component Number.
- (b) Traceability Information.

These components being too small to accommodate the marking specified above, the ESCC marking information shall accompany the component in its primary package.

4.5.2 The ESCC Component Number

The ESCC Component Number shall be constituted and marked as follows:

Example: 340108401B

- Detail Specification Number: 3401084
- Type Variant (See Figure 1(a)): 01
- Testing Level: B

4.5.3 Traceability Information

Traceability information shall be marked in accordance with ESCC Basic Specification No. 21700.

4.6 ELECTRICAL MEASUREMENTS

Not applicable.

4.7 SCREENING TESTS (TABLES 4 AND 5)

Not applicable.

4.8 ENVIRONMENTAL AND ENDURANCE TESTS

Not applicable.