



**CONNECTORS, ELECTRICAL, RECTANGULAR,
MICROMINIATURE
BASED ON TYPE MDM**

ESCC Detail Specification No. 3401/029

Issue 14	December 2016
----------	---------------



LEGAL DISCLAIMER AND COPYRIGHT

European Space Agency, Copyright © 2016. All rights reserved.

The European Space Agency disclaims any liability or responsibility, to any person or entity, with respect to any loss or damage caused, or alleged to be caused, directly or indirectly by the use and application of this ESCC publication.

This publication, without the prior permission of the European Space Agency and provided that it is not used for a commercial purpose, may be:

- copied in whole, in any medium, without alteration or modification.
- copied in part, in any medium, provided that the ESCC document identification, comprising the ESCC symbol, document number and document issue, is removed.

DOCUMENTATION CHANGE NOTICE

(Refer to <https://escies.org> for ESCC DCR content)

DCR No.	CHANGE DESCRIPTION
1010	Specification upissued to incorporate editorial changes per DCR.

TABLE OF CONTENTS

1	GENERAL	6
1.1	SCOPE	6
1.2	RANGE OF COMPONENTS	6
1.3	MAXIMUM RATINGS	6
1.4	PARAMETER DERATING INFORMATION	6
1.5	PHYSICAL DIMENSIONS	6
1.6	CONTACT ARRANGEMENTS	6
2	APPLICABLE DOCUMENTS	46
3	TERMS, DEFINITIONS, ABBREVIATIONS, SYMBOLS AND UNITS	46
4	REQUIREMENTS	46
4.1	GENERAL	46
4.2	DEVIATIONS FROM GENERIC SPECIFICATION	47
4.2.1	Deviations from Special In-Process Controls	47
4.2.2	Deviations from Final Production Tests (Chart II)	47
4.2.3	Deviations from Burn-in and Electrical Measurements (Chart III)	47
4.2.4	Deviations from Qualification Tests (Chart IV)	47
4.2.5	Deviations from Lot Acceptance Tests (Chart V)	47
4.3	MECHANICAL REQUIREMENTS	47
4.3.1	Dimension Check	47
4.3.2	Weight	47
4.3.3	Contact Capability	48
4.3.4	Contact Retention (in Insert)	48
4.3.5	Mating and Unmating Forces	48
4.3.6	Insert Retention (in Shell)	48
4.3.7	Jackscrew Retention	48
4.3.8	Contact Insertion and Withdrawal Forces	48
4.3.9	Engagement and Separation Forces (Male Contacts)	48
4.3.10	Oversize Pin Exclusion	48
4.3.11	Probe Damage	48
4.3.12	Solderability	48
4.4	MATERIALS AND FINISHES	49
4.4.1	Shells	49
4.4.2	Inserts	49
4.4.3	Contacts	49
4.4.3.1	Female Contacts	49
4.4.3.2	Male Contacts	49
4.4.4	Interfacial Seals	49

4.4.5	Insulated Wires	49
4.4.6	Uninsulated Solid Wire	49
4.4.7	Rear Potting	49
4.5	MARKING	50
4.5.1	General	50
4.5.2	The ESCC Component Number	50
4.5.3	Characteristics	50
4.5.3.1	Shell Size	50
4.5.3.2	Contact Type	50
4.5.3.3	Termination Type	51
4.5.3.4	Mounting	51
4.5.4	Traceability Information	51
4.6	ELECTRICAL MEASUREMENTS	52
4.6.1	Electrical Measurements at Room Temperature	52
4.6.2	Electrical Measurements at High and Low Temperatures	52
4.6.3	Circuits for Electrical Measurements	52
4.7	BURN-IN AND ELECTRICAL MEASUREMENTS (TABLES 4 AND 5)	52
4.8	ENVIRONMENTAL AND ENDURANCE TESTS (CHARTS IV AND V OF ESCC GENERIC SPECIFICATION NO. 3401)	54
4.8.1	Measurements and Inspections on Completion of Environmental Tests	54
4.8.2	Measurements and Inspections at Intermediate Points during Endurance Tests	54
4.8.3	Measurements and Inspections on Completion of Endurance Tests	54
4.8.4	Conditions for Operating Life Test (Part of Endurance Testing)	54
4.8.5	Electrical Circuit for Operating Life Test	54
4.8.6	Conditions for High Temperature Storage Test (Part of Endurance Testing)	54
	APPENDIX 'A'	58

1 GENERAL

1.1 SCOPE

This specification details the ratings, physical and electrical characteristics, test and inspection data for Electrical, Rectangular, Microminiature Connectors with Non-Removable Crimp-type Contacts and their associated insulated wires and uninsulated solid wires, based on type MDM.

It shall be read in conjunction with:

- ESCC Generic Specification No. [3401](#), Connectors, Electrical, Rectangular and Circular.
- ESCC Detail Specification No. [3401/032](#), Accessories for Connectors, Microminiature, [3401/029](#), [3401/077](#) and Connector Savers [3401/041](#).
- ESCC Detail Specification No. [3401/087](#), Lightweight Accessories for Rectangular, Microminiature Connectors, [3401/029](#) and [3401/077](#).

the requirements of which are supplemented herein.

1.2 RANGE OF COMPONENTS

The different sizes of the basic type connectors specified herein, which are also covered by this specification, together with their mechanical characteristics, are scheduled in Table 1(a). The different sizes of associated insulated wires and uninsulated solid wires are given in Figure 2.

1.3 MAXIMUM RATINGS

The maximum ratings, which shall not be exceeded at any time during use or storage, applicable to the connectors specified herein, are given in Table 1(b).

1.4 PARAMETER DERATING INFORMATION

The derating information applicable to the connectors specified herein is shown in Figure 1.

1.5 PHYSICAL DIMENSIONS

The physical characteristics of the connectors, insulated wires and uninsulated solid wires specified herein are shown in Figure 2.

1.6 CONTACT ARRANGEMENTS

Contact arrangements are shown in Figure 3.

TABLE 1(a) - RANGE OF COMPONENTS

Variants		Shell Size	Weight Max g						Mating Force N Max	Unmating Force	
Shell Finish			FR11x and FR12x (1) (3)	FR136 (2)	FR136A (2)	FR139 (2)	GMR7580	GMR7590		N Max	N Min
Nickel	Gold										
01	02	9	2.2	7.4	7.4	4.6	3.6	3.5	20	20	1.3
01	02	15	3	7.8	N/A	5	4.3	4.3	33	33	2
01	02	21	3.8	8.5	N/A	5.4	5.1	5	47	47	2.9
01	02	25	4.3	10.2	N/A	6.5	5.4	5.6	55	55	3.5
01	02	31	5.1	12.2	N/A	7.7	6.2	6.5	69	69	4.3
01	02	37	5.9	14.4	N/A	9.2	7	7.3	82	82	5.1
01	02	51	7.2	16.5	N/A	10.5	8.1	9.2	113	113	7.1
01	02	69	N/A	N/A	N/A	N/A	14.2	17	153	153	9.6
01	02	100	N/A	N/A	N/A	N/A	20.9	25.5	222	222	13.9

NOTES:

1. Connector contacts and rear potting, without cables, without floating eyelets and without captive nut. Add 0.4g for connectors with floating mounts and 1g for connectors with captive nuts. See Figures 2.4 and 2.5 for the weight of cable.
2. Connector with contacts and rear potting.
3. Includes termination type codes: FR112 to FR116, FR112A to FR115A, FR112B to FR115B, and FR123, FR123A, FR123B.

TABLE 1(b) - MAXIMUM RATINGS

No.	Characteristic	Symbol	Maximum Rating	Unit	Remarks
1	Working Voltage Sea Level	U_R	150	Vrms	Note 1
2	Rated Current: (AWG26 and uninsulated solid wire)	I_R	2.5	A	
3	Rated Current: (AWG28)	I_R	1.5	A	
4	Operating Temperature Range	T_{op}	-55 to +125	°C	
5	Storage Temperature Range	T_{stg}	-55 to +125	°C	

NOTES:

1. Between contacts, and contact and shell.

FIGURE 1 - PARAMETER DERATING INFORMATION

FIGURE 1(a) - WORKING VOLTAGE VERSUS ALTITUDE

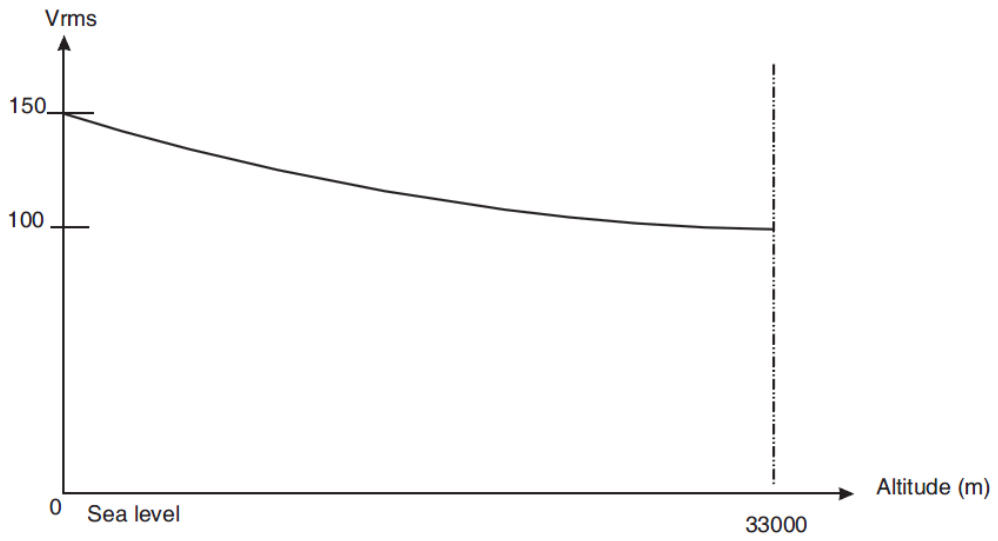
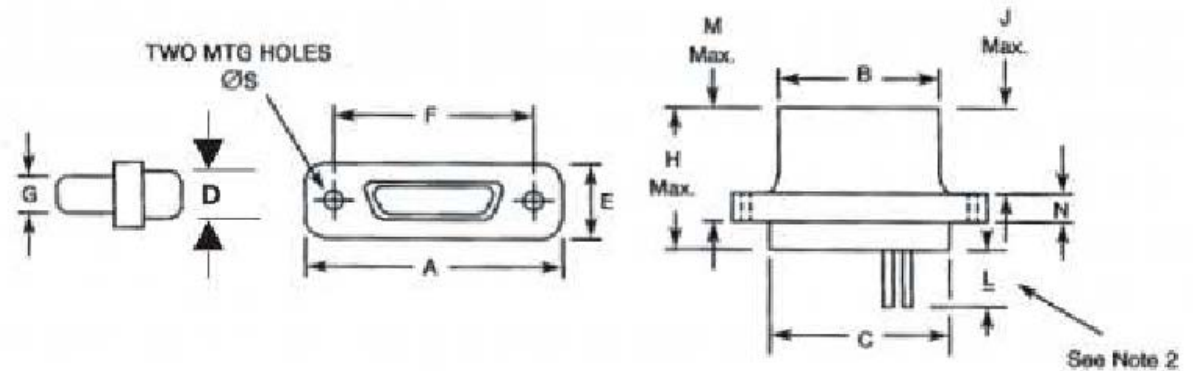

FIGURE 1(b) - MAXIMUM CURRENT VERSUS NUMBER OF CONTACTS

NUMBER OF CURRENT-CARRYING CONTACTS PER CONNECTOR	MAXIMUM CURRENT PER CONTACT (A)	
	WIRE SIZE	
	AWG26 AND UNINSULATED SOLID WIRE	AWG 28
2 - 4	2	1.4
5 - 14	1.8	1.2
15 and over	1.4	0.9

FIGURE 2 - PHYSICAL DIMENSIONS

FIGURE 2.1A CONNECTOR SHELLS - PLUG MALE CONTACT



SHELL SIZE	A Max	B Max	C Max	D Max	E Max	E		G Max	H Max	J Max	M Max	N		ØS	
						Min	Max					Min	Max	Min	Max
9	19.94	8.46	10.16	6.86	7.82	14.22	14.48	4.69	10.57	4.72	7.26	2.23	2.49	2.23	2.39
15	23.75	12.27	13.97	6.86	7.82	18.03	18.29	4.69	10.57	4.72	7.26	2.23	2.49	2.23	2.39
21	27.56	16.08	17.78	6.86	7.82	21.84	22.1	4.69	10.57	4.72	7.26	2.23	2.49	2.23	2.39
25	30.1	18.62	20.32	6.86	7.82	24.38	24.64	4.69	10.57	4.72	7.26	2.23	2.49	2.23	2.39
31	33.91	22.43	24.13	6.86	7.82	28.19	28.45	4.69	10.57	4.72	7.26	2.23	2.49	2.23	2.39
37	37.72	26.24	27.94	6.86	7.82	32	32.26	4.69	10.57	4.72	7.26	2.23	2.49	2.23	2.39
51	36.45	24.97	26.67	7.87	8.92	30.73	30.99	5.78	10.57	4.72	7.26	2.23	2.49	2.23	2.39

NOTES:

1. All dimensions are in millimetres.
2. For minimum length of L refer to Para. 4.5.3.3 of this specification

FIGURE 2.1B CONNECTOR SHELLS - RECEPTACLE FEMALE CONTACTS

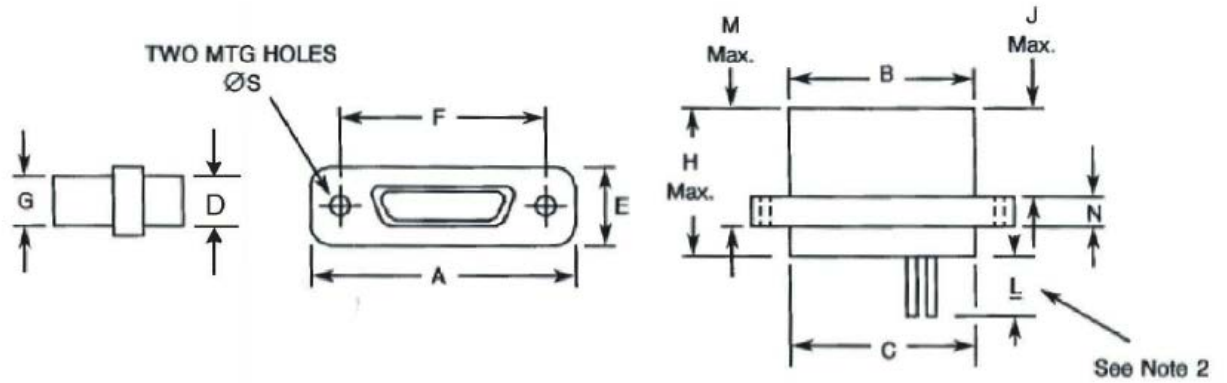

SHELL SIZE	A Max	B Max	C Max	D Max	E Max	E		G Max	H Max	J Max	M Max	N		ØS	
						Min	Max					Min	Max	Min	Max
9	19.94	10.16	10.16	6.86	7.82	14.22	14.48	6.38	10.9	5.05	7.59	2.23	2.49	2.23	2.39
15	23.75	13.97	13.97	6.86	7.82	18.03	18.29	6.38	10.9	5.05	7.59	2.23	2.49	2.23	2.39
21	27.56	17.78	17.78	6.86	7.82	21.84	22.1	6.38	10.9	5.05	7.59	2.23	2.49	2.23	2.39
25	30.1	20.32	20.32	6.86	7.82	24.38	24.64	6.38	10.9	5.05	7.59	2.23	2.49	2.23	2.39
31	33.91	24.13	24.13	6.86	7.82	28.19	28.45	6.38	10.9	5.05	7.59	2.23	2.49	2.23	2.39
37	37.72	27.94	27.94	6.86	7.82	32	32.26	6.38	10.9	5.05	7.59	2.23	2.49	2.23	2.39
51	36.45	26.67	26.67	7.87	8.92	30.73	30.99	7.47	10.9	5.05	7.59	2.23	2.49	2.23	2.39

NOTES:

1. All dimensions are in millimetres.
2. For minimum length of \underline{L} refer to Para. 4.5.3.3 of this specification

FIGURE 2.2A - CONNECTORS TYPE - FR136
PLUG MALE CONTACTS

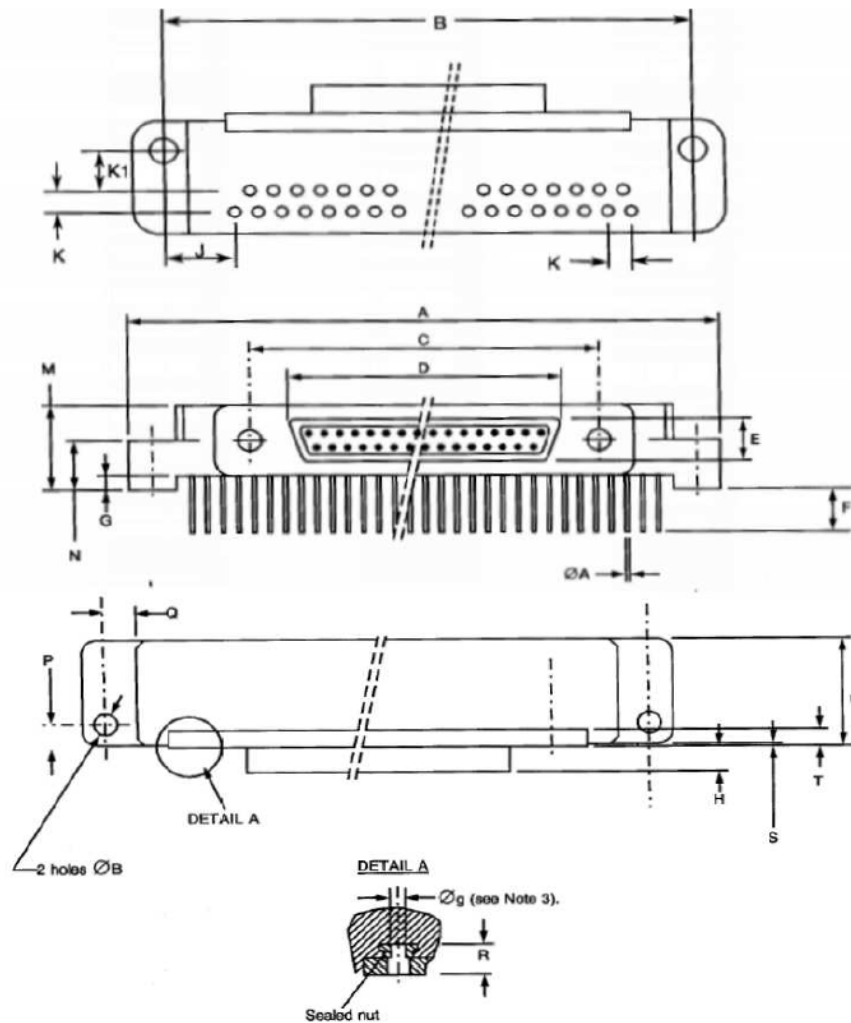

Shell Size	A		B		ØB (4)		C		D	E	E		G		H	J
	Max.	Min.	Max.	Min.	Max.	Min.	Max.	Max.	Max.	Min.	Max.	Min.	Max.	Max.	Typ.	
9	35.31	29.03	29.39	2.31	2.59	14.22	14.48	8.46	4.69	4.15	4.85	0	1.7	4.72	9.53	
15	39.12	32.84	33.2	2.31	2.59	18.03	18.29	12.27	4.69	4.15	4.85	0	1.7	4.72	7.62	
21	42.93	36.65	37.01	2.31	2.59	21.84	22.1	16.08	4.69	4.15	4.85	0	1.7	4.72	5.72	
25	45.47	39.19	39.55	2.31	2.59	24.38	24.64	18.62	4.69	4.15	4.85	0	1.7	4.72	4.45	
31	51.82	45.54	45.9	2.31	2.59	28.19	28.45	22.43	4.69	4.15	4.85	0	1.7	4.72	3.81	
37	59.44	53.16	53.52	2.31	2.59	32	32.26	26.24	4.69	4.15	4.85	0	1.7	4.72	3.81	

Shell Size	K	K1		M		N		P		Q		R	S		T		U
	Typ.	Min.	Max.	Min.	Max.	Min.	Max.	Min.	Max.	Min.	Max.	Min.	Min.	Max.	Min.	Max.	Max.
9	2.54	3.56	4.06	9	9.2	5.15	5.45	2.79	3.55	2	2.1	4.55	0.2	0.4	2.23	2.49	11.56
15	2.54	3.56	4.06	9	9.2	5.15	5.45	2.79	3.55	2	2.1	4.55	0.2	0.4	2.23	2.49	11.56
21	2.54	3.56	4.06	9	9.2	5.15	5.45	2.79	3.55	2	2.1	4.55	0.2	0.4	2.23	2.49	11.56
25	2.54	3.56	4.06	9	9.2	5.15	5.45	2.79	3.55	2	2.1	4.55	0.2	0.4	2.23	2.49	11.56
31	2.54	3.56	4.06	9	9.2	5.15	5.45	2.79	3.55	2	2.1	4.55	0.2	0.4	2.23	2.49	11.56
37	2.54	3.56	4.06	9	9.2	5.15	5.45	2.79	3.55	2	2.1	4.55	0.2	0.4	2.23	2.49	11.56

NOTES:

1. All dimensions are in millimetres.
2. For ØA refer to Para. 4.5.3.3 of this specification.
3. Øg: 2-56-UNC-2B.
4. Maximum torque 0.44 Nm.

FIGURE 2.2B - CONNECTORS TYPE - FR136
RECEPTACLE FEMALE CONTACTS

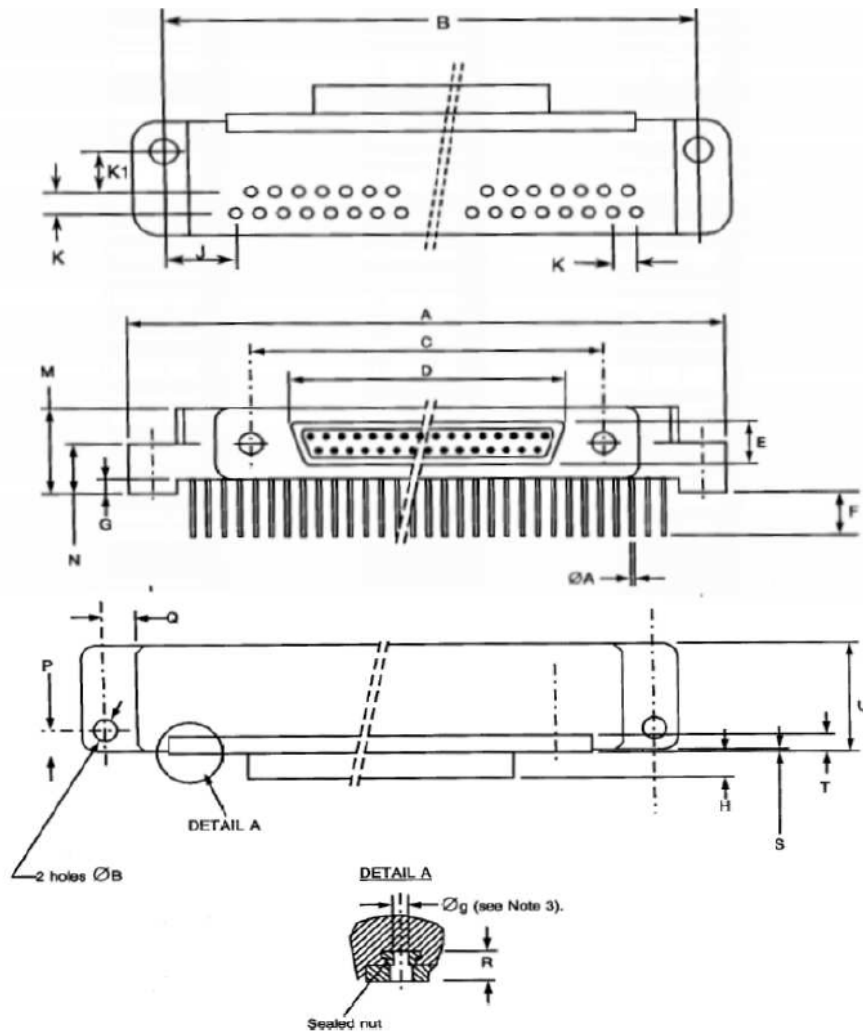

Shell Size	A		B		ØB (4)		C		D	E	E		G		H	J
	Max.	Min.	Max.	Min.	Max.	Min.	Max.	Max.	Max.	Min.	Max.	Min.	Max.	Max.	Typ.	
9	35.31	29.03	29.39	2.31	2.59	14.22	14.48	10.16	6.38	4.15	4.85	0	1.7	5.05	9.53	
15	39.12	32.84	33.2	2.31	2.59	18.03	18.29	13.97	6.38	4.15	4.85	0	1.7	5.05	7.62	
21	42.93	36.65	37.01	2.31	2.59	21.84	22.1	17.78	6.38	4.15	4.85	0	1.7	5.05	5.72	
25	45.47	39.19	39.55	2.31	2.59	24.38	24.64	20.32	6.38	4.15	4.85	0	1.7	5.05	4.45	
31	51.82	45.54	45.9	2.31	2.59	28.19	28.45	24.13	6.38	4.15	4.85	0	1.7	5.05	3.81	
37	59.44	53.16	53.52	2.31	2.59	32	32.26	27.94	6.38	4.15	4.85	0	1.7	5.05	3.81	

Shell Size	K	K1		M		N		P		Q		R	S		T		U
	Typ..	Min.	Max.	Min.	Max.	Min.	Max.	Min.	Max.	Min.	Max.	Min.	Min.	Max.	Min.	Max.	Max.
9	2.54	3.56	4.06	9	9.2	5.15	5.45	2.79	3.55	2	2.1	4.55	0.2	0.4	2.23	2.49	11.56
15	2.54	3.56	4.06	9	9.2	5.15	5.45	2.79	3.55	2	2.1	4.55	0.2	0.4	2.23	2.49	11.56
21	2.54	3.56	4.06	9	9.2	5.15	5.45	2.79	3.55	2	2.1	4.55	0.2	0.4	2.23	2.49	11.56
25	2.54	3.56	4.06	9	9.2	5.15	5.45	2.79	3.55	2	2.1	4.55	0.2	0.4	2.23	2.49	11.56
31	2.54	3.56	4.06	9	9.2	5.15	5.45	2.79	3.55	2	2.1	4.55	0.2	0.4	2.23	2.49	11.56
37	2.54	3.56	4.06	9	9.2	5.15	5.45	2.79	3.55	2	2.1	4.55	0.2	0.4	2.23	2.49	11.56

NOTES:

1. All dimensions are in millimetres.
2. For ØA refer to Para. 4.5.3.3 of this specification.
3. Øg: 2-56-UNC-2B.
4. Maximum torque 0.44 Nm.

FIGURE 2.2C - CONNECTORS TYPE - FR136
PLUG MALE CONTACTS

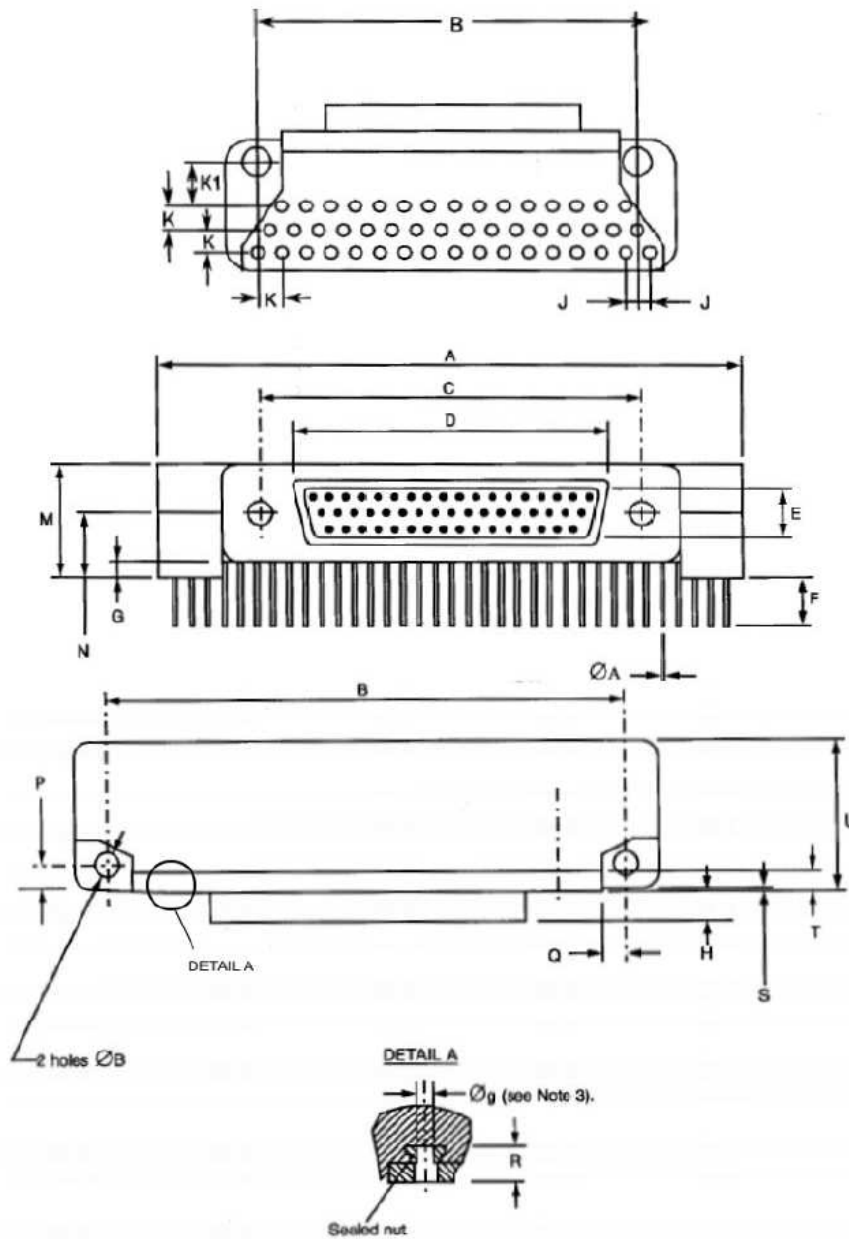

Shell Size	A	B		$\varnothing B$ (4)		C		D	E	E		G		H	J
	Max.	Min.	Max.	Min.	Max.	Min.	Max.	Max.	Max.	Min.	Max.	Min.	Max.	Max.	Typ.
51	47.63	40.46	40.82	2.31	2.59	30.73	30.99	24.97	5.78	4.15	4.85	0	1.7	4.72	1.27

Shell Size	K	K1		M		N		P		Q		R	S		T	U	
	Typ.	Min.	Max.	Min.	Max.	Min.	Max.	Min.	Max.	Min.	Max.	Min.	Min.	Max.	Min.	Max.	Max.
51	2.54	3.56	4.06	10.1	10.4	5.81	6.11	2.79	3.55	2.05	2.15	4.55	0.2	0.4	2.23	2.49	14.35

NOTES:

1. All dimensions are in millimetres.
2. For ØA refer to Para. 4.5.3.3 of this specification.
3. Øg: 2-56-UNC-2B.
4. Maximum torque 0.44 Nm.

FIGURE 2.2D - CONNECTORS TYPE - FR136
RECEPTACLE FEMALE CONTACTS

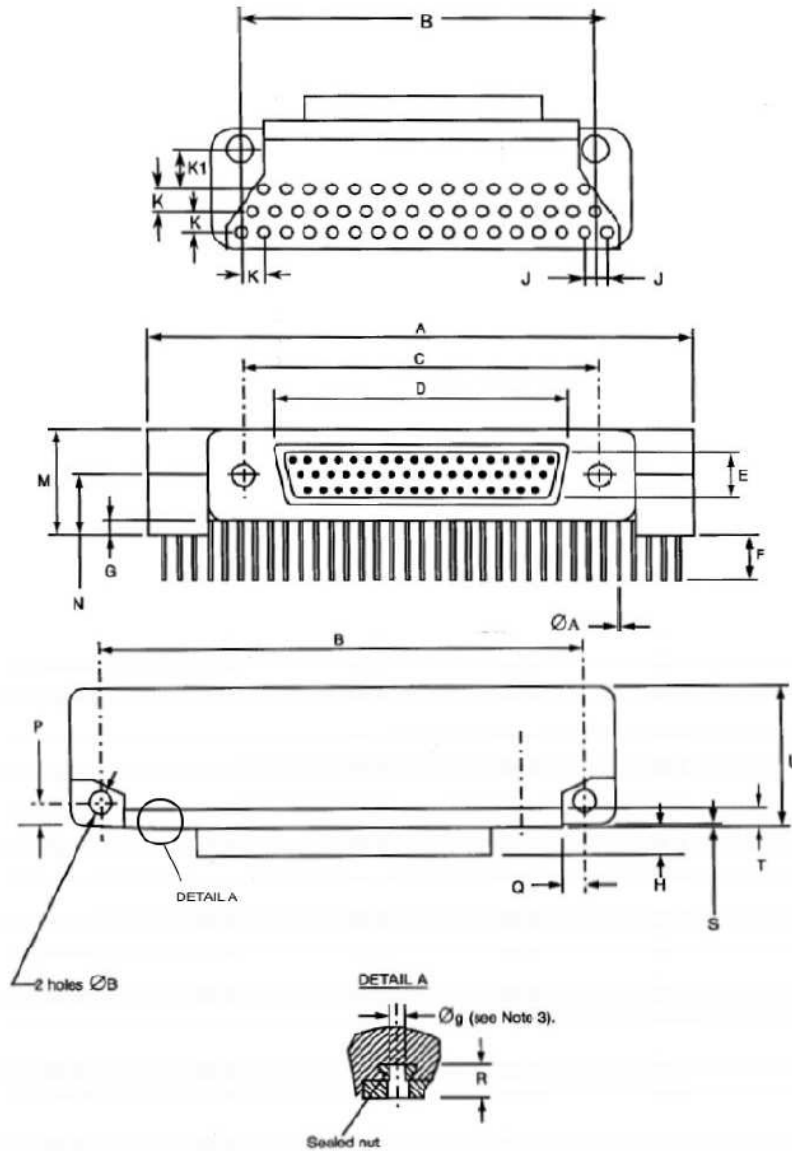

Shell Size	A		B		ØB (4)		C		D	E	E		G		H	J
	Max.	Min.	Max.	Min.	Max.	Min.	Max.	Max.	Max.	Min.	Max.	Min.	Max.	Max.	Typ.	
51	47.63	40.46	40.82	2.31	2.59	30.73	30.99	26.67	7.47	4.15	4.85	0	1.7	5.05	1.27	

Shell Size	K	K1		M		N		P		Q		R	S		T		U
	Typ.	Min.	Max.	Min.	Max.	Min.	Max.	Min.	Max.	Min.	Max.	Min.	Min.	Max.	Min.	Max.	Max.
51	2.54	3.56	4.06	10.1	10.4	5.81	6.11	2.79	3.55	2.05	2.15	4.55	0.2	0.4	2.23	2.49	14.35

NOTES:

1. All dimensions are in millimetres.
2. For ØA refer to Para. 4.5.3.3 of this specification.
3. Øg: 2-56-UNC-2B.
4. Maximum torque 0.44 Nm.

FIGURE 2.2E - CONNECTORS TYPE - FR136A
PLUG MALE CONTACTS

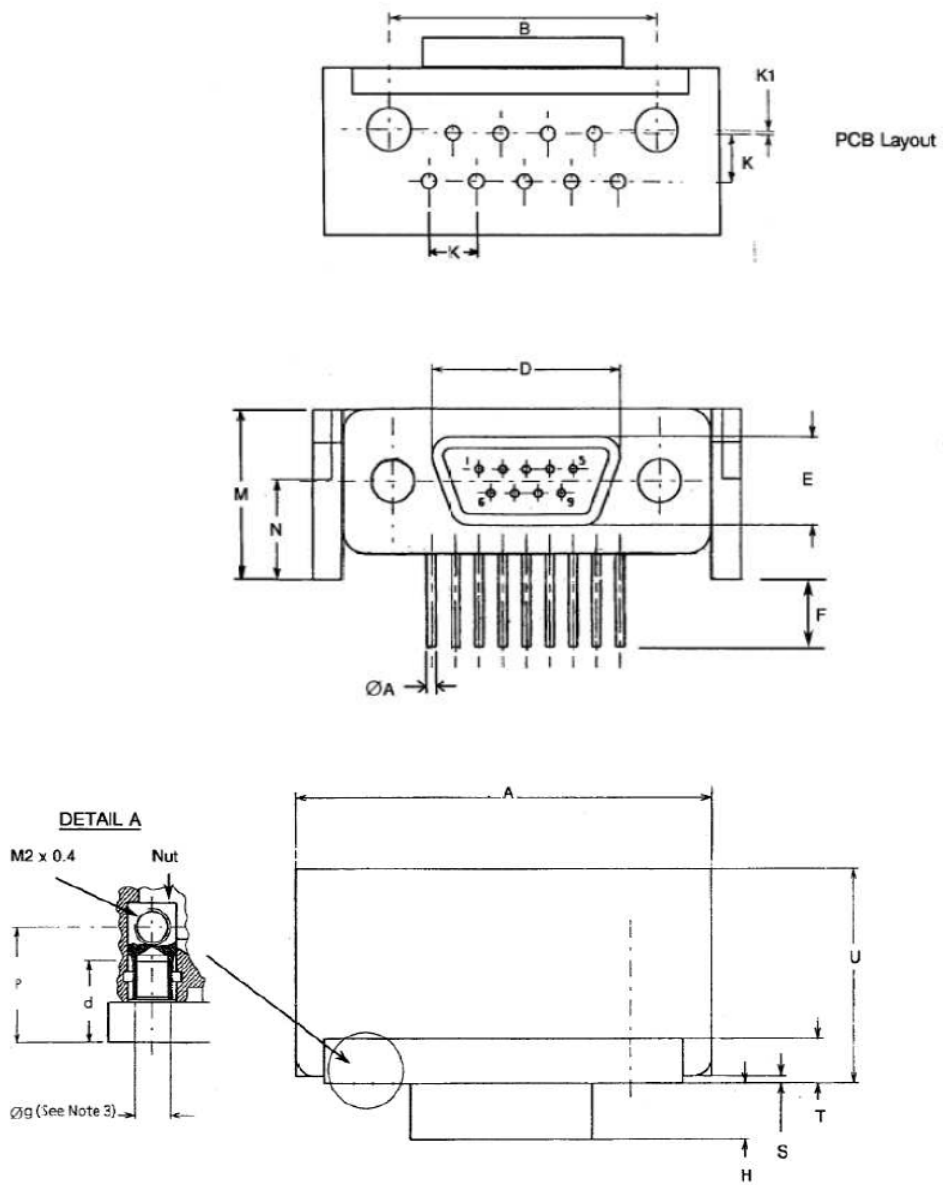

Shell Size	A	B		d	D	E		H	K	K1	
	Max.	Min.	Max.	Min.	Max.	Min.	Max.	Max.	Typ.	Typ.	
9	23.12	14.22	14.48	4.8	8.46	4.69	3.3	3.7	4.72	2.54	0.2

Shell Size	M		N		P		S		T		U
	Min.	Max.	Min.	Max.	Min.	Max.	Min.	Max.	Min.	Max.	Max.
9	9	9.2	5.15	5.45	6.48	7.24	0.2	0.4	2.23	2.49	11.5

NOTES:

1. All dimensions are in millimetres.
2. For ØA refer to Para. 4.5.3.3 of this specification.
3. Øg: 2-56-UNC-2B.

FIGURE 2.2F - CONNECTORS TYPE - FR136A
RECEPTACLE FEMALE CONTACTS

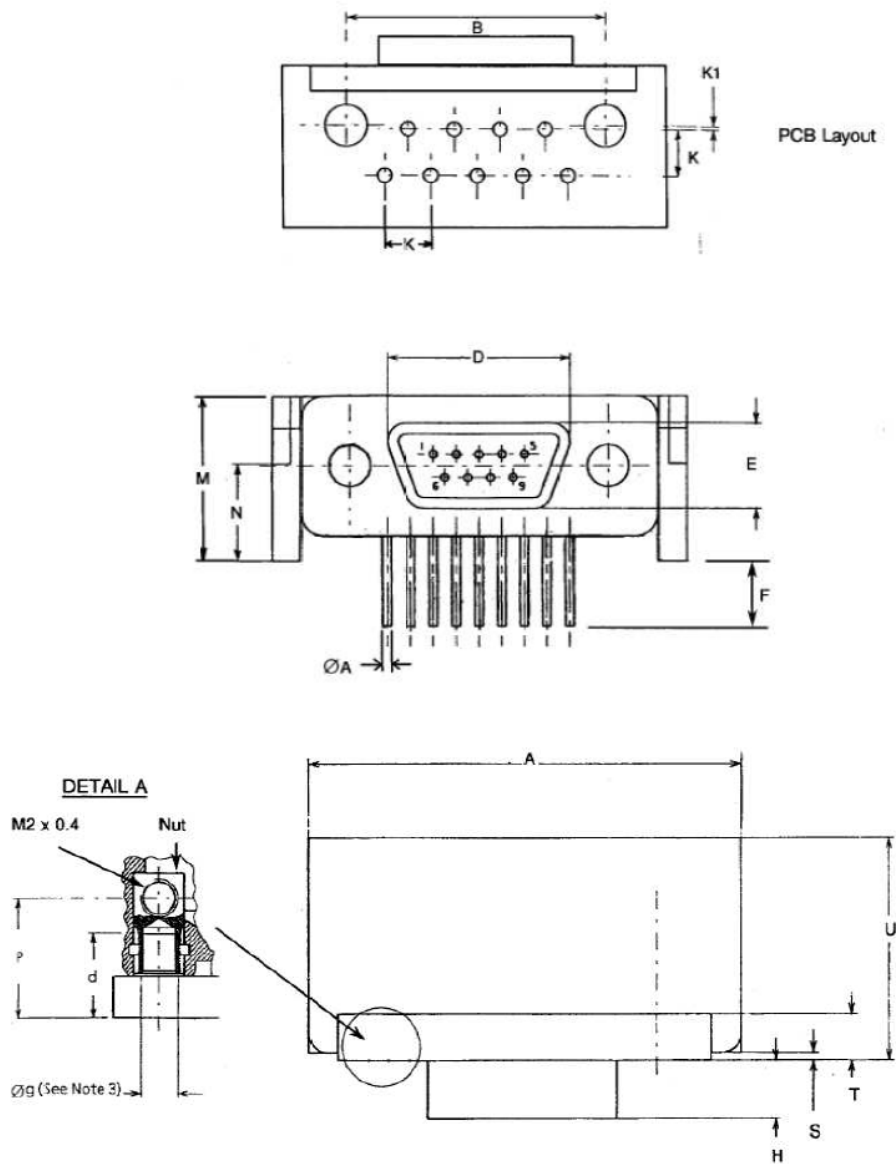

Shell Size	A	B		d	D	E		H	K	K1	
	Max.	Min.	Max.	Min.	Max.	Max.	Min.	Max.	Typ.	Typ.	
9	23.12	14.22	14.48	4.8	10.16	6.38	3.3	3.7	5.05	2.54	0.2

Shell Size	M		N		P		S		T		U
	Min.	Max.	Min.	Max.	Min.	Max.	Min.	Max.	Min.	Max.	Max.
9	9	9.2	5.15	5.45	6.48	7.24	0.2	0.4	2.23	2.49	11.5

NOTES:

1. All dimensions are in millimetres.
2. For ØA refer to Para. 4.5.3.3 of this specification.
3. Øg: 2-56-UNC-2B.

FIGURE 2.2G - CONNECTORS TYPE - FR139

PLUG MALE CONTACTS

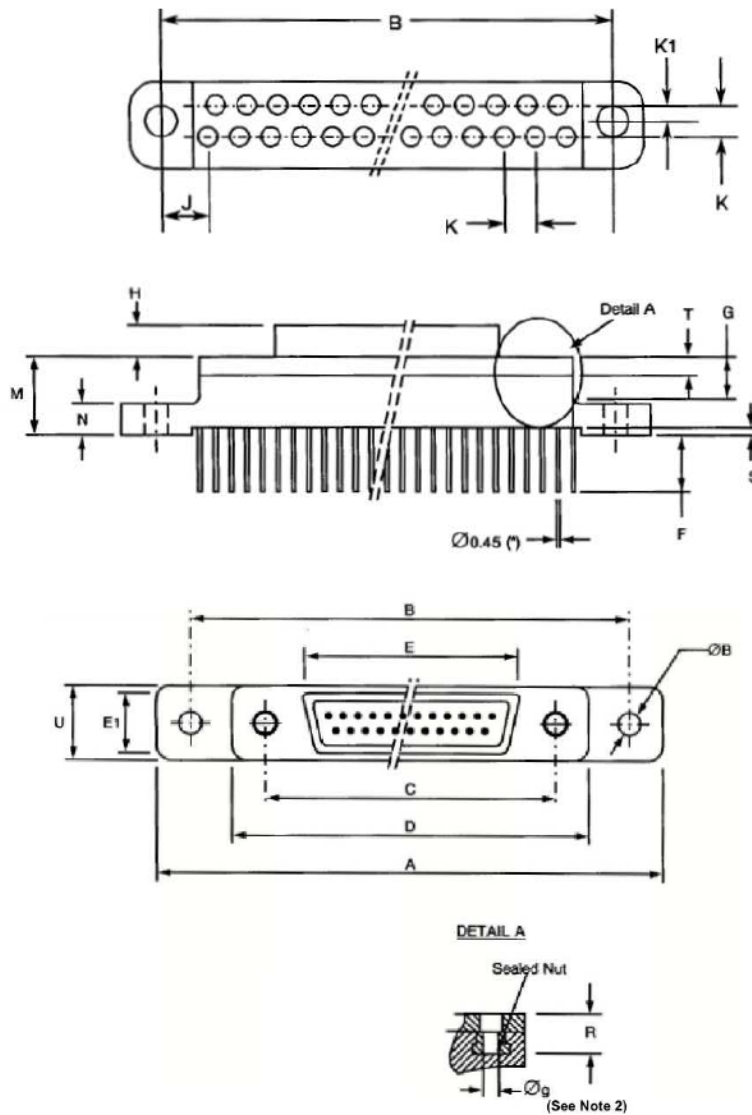

Shell Size	A		B		ØB (3)		C		D	E	E1	E		G	H	J
	Max.	Min.	Max.	Min.	Max.	Min.	Max.	Max.	Max.	Max.	Min.	Max.	Min.	Max.	Typ.	
9	35.31	29.03	29.39	2.31	2.59	14.22	14.48	19.94	8.46	4.69	4.15	4.85	4.6	4.72	9.53	
15	35.31	29.03	29.39	2.31	2.59	18.03	18.29	23.75	12.27	4.69	4.15	4.85	4.6	4.72	5.72	
21	42.93	36.65	37.01	2.31	2.59	21.84	22.1	27.56	16.08	4.69	4.15	4.85	4.6	4.72	5.72	
25	44.2	37.92	38.28	2.31	2.59	24.38	24.64	30.1	18.62	4.69	4.15	4.85	4.6	4.72	3.81	
31	51.82	45.54	45.9	2.31	2.59	28.19	28.45	33.91	22.43	4.69	4.15	4.85	4.6	4.72	3.81	
37	59.44	53.16	53.52	2.31	2.59	32	32.26	37.72	26.64	4.69	4.15	4.85	4.6	4.72	3.81	

Shell Size	K	K1	M		<u>N</u>		R	S		T		U
	Typ.	Typ.	Min.	Max.	Min.	Max.	Min.	Min.	Max.	Min.	Max.	Max.
9	2.54	1.27	8.62	9.02	4	4.2	4.55	0	1.1	2.23	2.49	7.82
15	2.54	1.27	8.62	9.02	4	4.2	4.55	0	1.1	2.23	2.49	7.82
21	2.54	1.27	8.62	9.02	4	4.2	4.55	0	1.1	2.23	2.49	7.82
25	2.54	1.27	8.62	9.02	4	4.2	4.55	0	1.1	2.23	2.49	7.82
31	2.54	1.27	8.62	9.02	4	4.2	4.55	0	1.1	2.23	2.49	7.82
37	2.54	1.27	8.62	9.02	4	4.2	4.55	0	1.1	2.23	2.49	7.82

NOTES:

1. All dimensions are in millimetres.
2. Øg: 2-56-UNC-2B.
3. Maximum torque 0.44 Nm.

FIGURE 2.2H - CONNECTORS TYPE - FR139
RECEPTACLE FEMALE CONTACTS

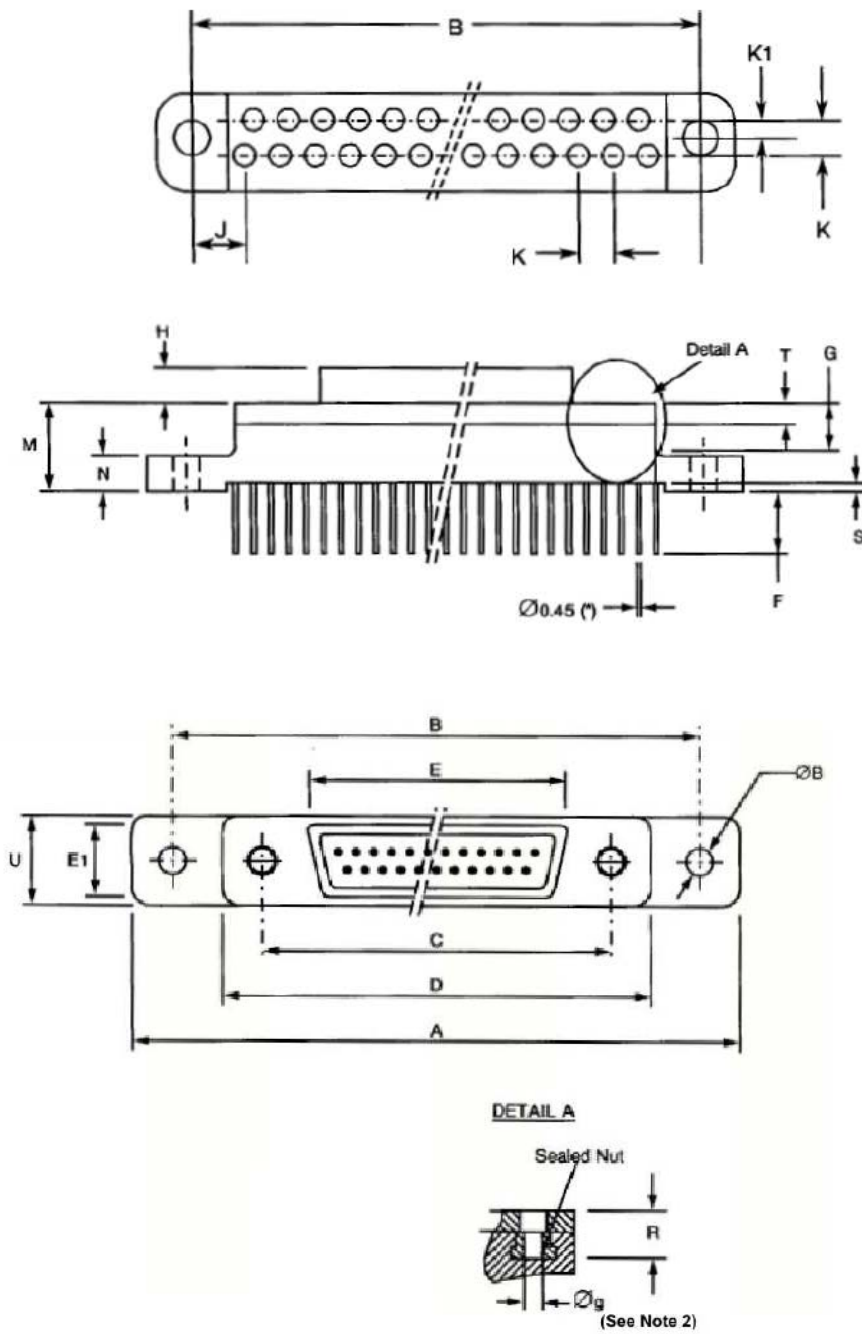

Shell Size	A	B		ØB (3)		C		D	E	E1	E		G	H	J
	Max.	Min.	Max.	Min.	Max.	Min.	Max.	Max.	Max.	Max.	Min.	Max.	Min.	Max.	Typ.
9	35.31	29.03	29.39	2.31	2.59	14.22	14.48	19.94	10.16	6.38	4.15	4.85	4.6	5.05	9.53
15	35.31	29.03	29.39	2.31	2.59	18.03	18.29	23.75	13.97	6.38	4.15	4.85	4.6	5.05	5.72
21	42.93	36.65	37.01	2.31	2.59	21.84	22.1	27.56	17.78	6.38	4.15	4.85	4.6	5.05	5.72
25	44.2	37.92	38.28	2.31	2.59	24.38	24.64	30.1	20.32	6.38	4.15	4.85	4.6	5.05	3.81
31	51.82	45.54	45.9	2.31	2.59	28.19	28.45	33.91	24.13	6.38	4.15	4.85	4.6	5.05	3.81
37	59.44	53.16	53.52	2.31	2.59	32	32.26	37.72	27.94	6.38	4.15	4.85	4.6	5.05	3.81

Shell Size	K	K1	M		N		R	S		T		U
	Typ.	Typ.	Min.	Max.	Min.	Max.	Min.	Min.	Max.	Min.	Max.	Max.
9	2.54	1.27	8.62	9.02	4	4.2	4.55	0	1.1	2.23	2.49	7.82
15	2.54	1.27	8.62	9.02	4	4.2	4.55	0	1.1	2.23	2.49	7.82
21	2.54	1.27	8.62	9.02	4	4.2	4.55	0	1.1	2.23	2.49	7.82
25	2.54	1.27	8.62	9.02	4	4.2	4.55	0	1.1	2.23	2.49	7.82
31	2.54	1.27	8.62	9.02	4	4.2	4.55	0	1.1	2.23	2.49	7.82
37	2.54	1.27	8.62	9.02	4	4.2	4.55	0	1.1	2.23	2.49	7.82

NOTES:

1. All dimensions are in millimetres.
2. Øg: 2-56-UNC-2B.
3. Maximum torque 0.44 Nm.

**FIGURE 2.2I - CONNECTORS TYPE - FR139
PLUG MALE CONTACTS - SIZE 51**

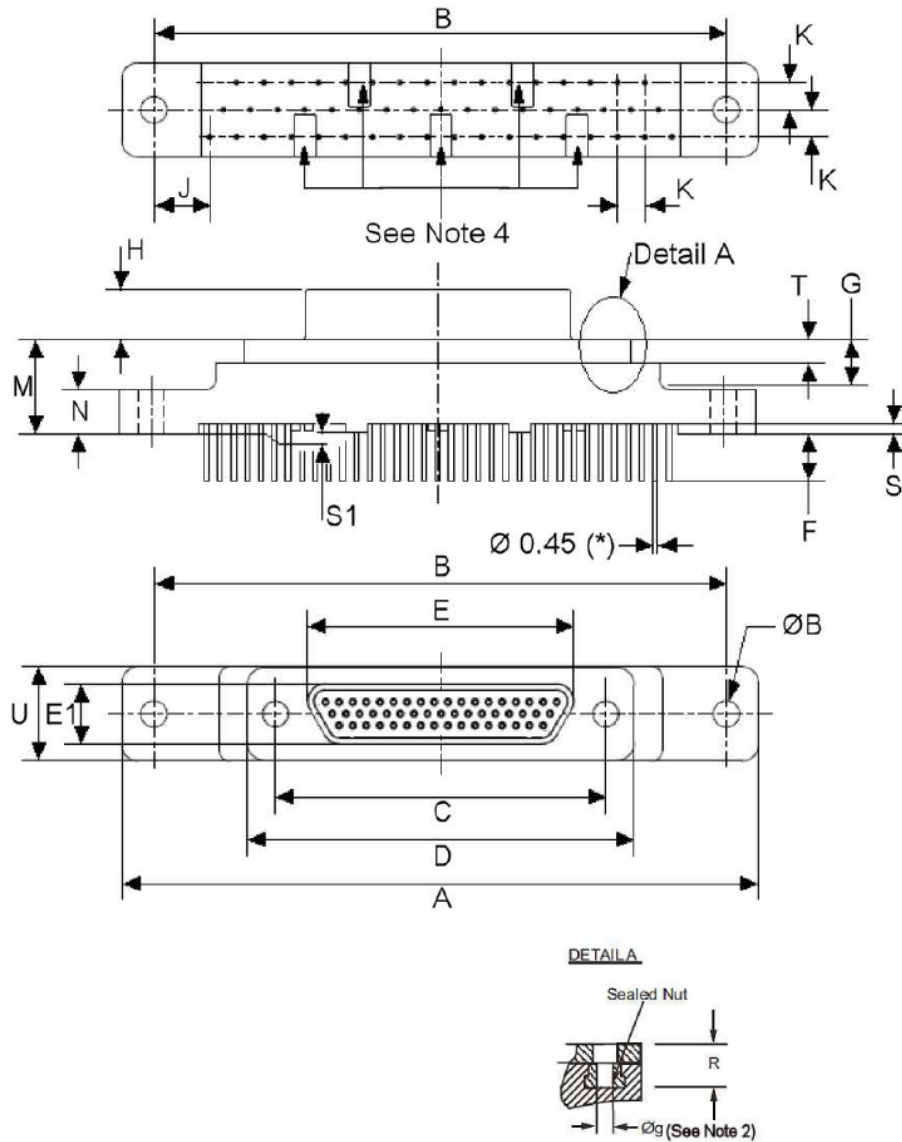

Shell Size	A		B		ØB (3)		C		D	E	E1	E		G	H	J
	Max.	Min.	Max.	Min.	Max.	Min.	Max.	Max.	Max.	Max.	Min.	Max.	Min.	Max.	Typ.	
51	59.44	53.16	53.52	2.31	2.59	30.73	30.99	36.5	24.97	5.78	4.15	4.85	4	4.72	5.08	

Shell Size	K	M		N		R	S		S1 (4)		T		U
	Typ.	Min.	Max.	Min.	Max.	Min.	Min.	Max.	Min.	Max.	Min.	Max.	Max.
51	2.54	8.62	9.02	4	4.2	4.55	0	1.1	0	0.2	2.23	2.49	9

NOTES:

1. All dimensions are in millimetres.
2. Øg: 2-56-UNC-2B.
3. Maximum torque 0.44 Nm.
4. Standoffs (5 places): 4.25 x 2.1 maximum.

**FIGURE 2.2J - CONNECTORS TYPE - FR139
RECEPTACLE FEMALE CONTACTS - SIZE 51**

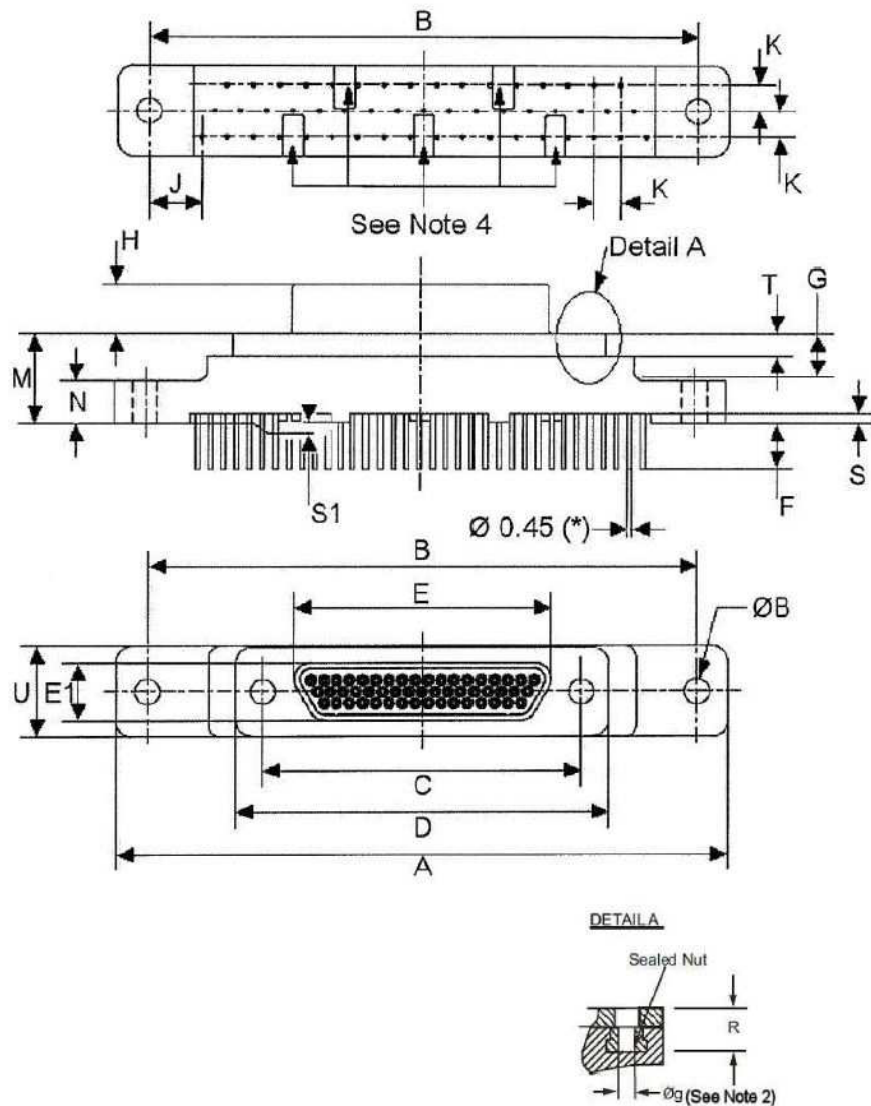

Shell Size	A	B		ØB (3)		C		D	E	E1	E		G	H	J
	Max.	Min.	Max.	Min.	Max.	Min.	Max.	Max.	Max.	Max.	Min.	Max.	Min.	Max.	Typ.
51	59.44	53.16	53.52	2.31	2.59	30.73	30.99	36.5	26.67	7.47	4.15	4.85	4	5.05	5.08

Shell Size	K	M		N		R	S		S1 (4)		T		U
	Typ.	Min.	Max.	Min.	Max.	Min.	Min.	Max.	Min.	Max.	Min.	Max.	Max.
51	2.54	8.62	9.02	4	4.2	4.55	0	1.1	0	0.2	2.23	2.49	9

NOTES:

1. All dimensions are in millimetres.
2. Øg: 2-56-UNC-2B.
3. Maximum torque 0.44 Nm.
4. Standoffs (5 places): 4.25 x 2.1 maximum.

FIGURE 2.2K - CONNECTORS TYPE – GMR7590

PLUG MALE CONTACTS

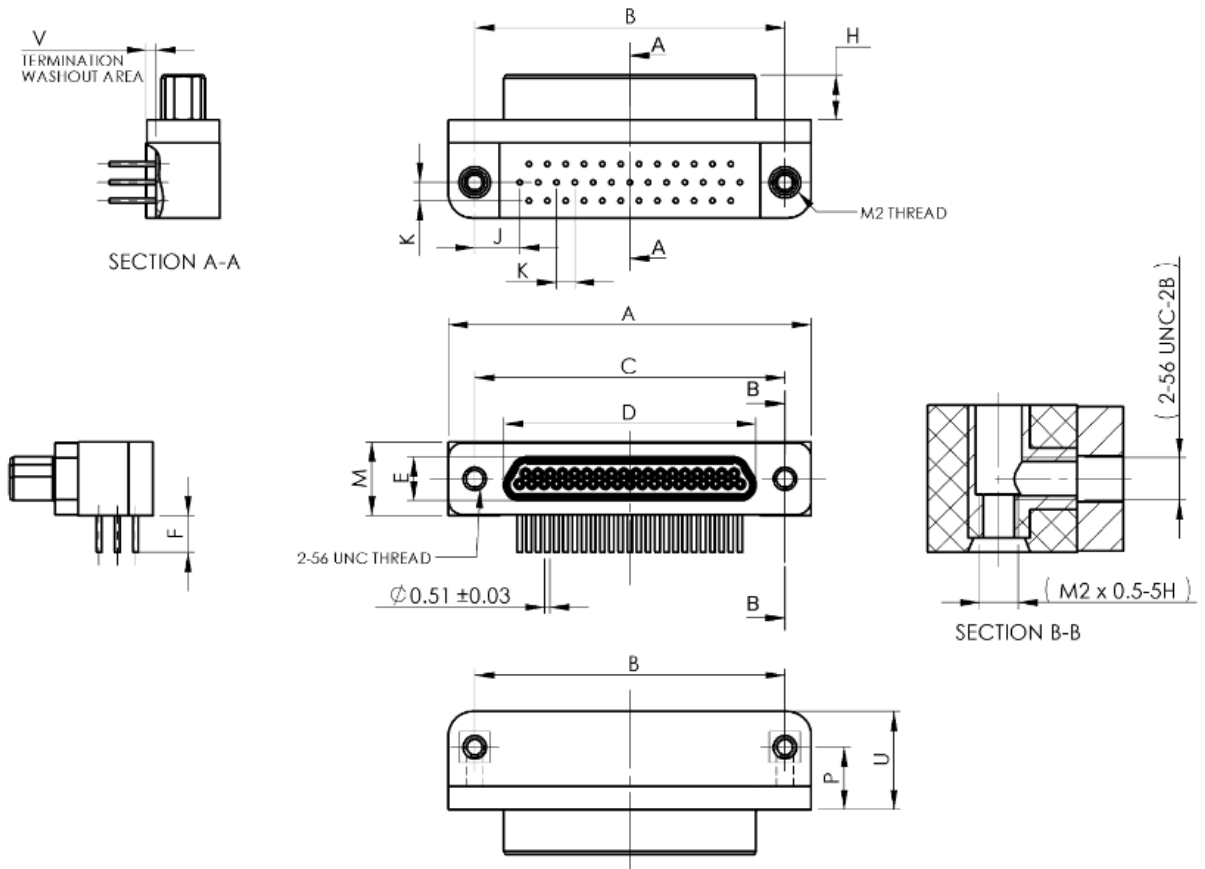

Shell Size	A	B		C		D	E	E	
	Max.	Min.	Max.	Min.	Max.	Max.	Max.	Min.	Max.
9	19.94	14.22	14.48	14.22	14.48	8.51	4.7	4.45	5.21
15	23.75	18.03	18.29	18.03	18.29	12.32	4.7	4.45	5.21
21	27.55	21.84	22.1	21.84	22.1	16.13	4.7	4.45	5.21
25	30.01	24.38	24.64	24.38	24.64	18.67	4.7	4.45	5.21
31	33.91	28.19	28.45	28.19	28.45	28.48	4.7	4.45	5.21
37	37.72	32	32.26	32	32.26	26.29	4.7	4.45	5.21

Shell Size	H		J	K	M		P		U	V	
	Min.	Max.	Typ.	Typ.	Min.	Max.	Min.	Max.	Max.	Min.	Max.
9	4.57	4.73	3.38	1.91	7.61	7.87	6.1	6.6	10.16	0.89	1.02
15	4.57	4.73	4.32	1.91	7.61	7.87	6.1	6.6	10.16	0.89	1.02
21	4.57	4.73	4.32	1.91	7.61	7.87	6.1	6.6	10.16	0.89	1.02
25	4.57	4.73	4.65	1.91	7.61	7.87	6.1	6.6	10.16	0.89	1.02
31	4.57	4.73	4.65	1.91	7.61	7.87	6.1	6.6	10.16	0.89	1.02
37	4.57	4.73	4.65	1.91	7.61	7.87	6.1	6.6	10.16	0.89	1.02

NOTES:

1. All dimensions are in millimetres.

FIGURE 2.2L - CONNECTORS TYPE – GMR7590
RECEPTACLE FEMALE CONTACTS

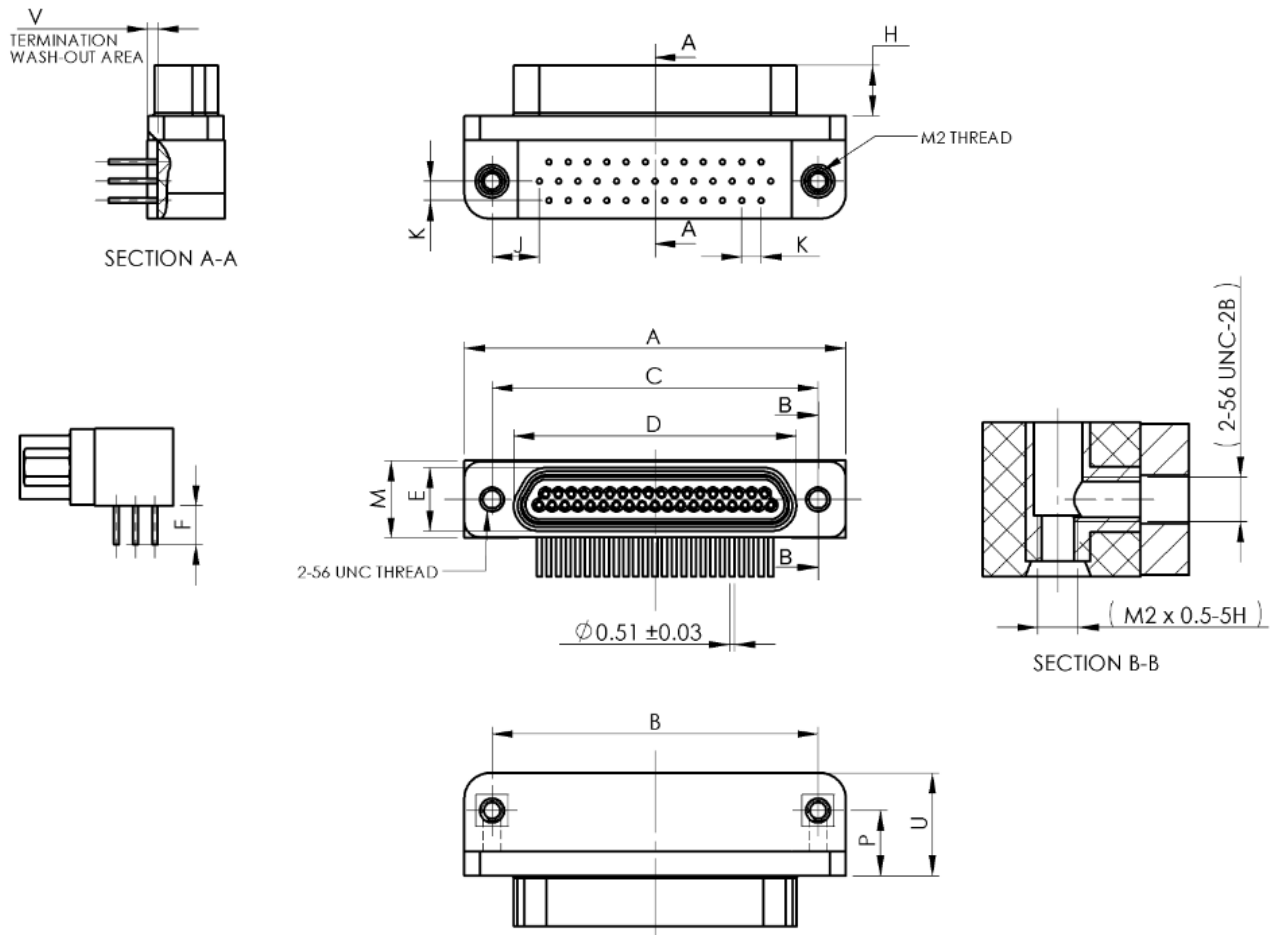

Shell Size	A	B		C		D	E	E	
	Max.	Min.	Max.	Min.	Max.	Max.	Max.	Min.	Max.
9	19.94	14.22	14.48	14.22	14.48	10.16	6.38	4.45	5.21
15	23.75	18.03	18.29	18.03	18.29	13.97	6.38	4.45	5.21
21	27.56	21.83	22.1	21.83	22.1	17.78	6.38	4.45	5.21
25	30.01	24.38	24.64	24.38	24.64	20.32	6.38	4.45	5.21
31	33.91	28.19	28.45	28.19	28.45	24.13	6.38	4.45	5.21
37	37.72	32	32.26	32	32.26	27.94	6.38	4.45	5.21

Shell Size	H		J	K	M		P		U	V	
	Min.	Max.	Typ.	Typ.	Min.	Max.	Min.	Max.	Max.	Min.	Max.
9	4.87	5.03	3.38	1.91	7.61	7.87	6.1	6.6	10.16	0.89	1.02
15	4.87	5.03	4.32	1.91	7.61	7.87	6.1	6.6	10.16	0.89	1.02
21	4.87	5.03	4.32	1.91	7.61	7.87	6.1	6.6	10.16	0.89	1.02
25	4.87	5.03	4.65	1.91	7.61	7.87	6.1	6.6	10.16	0.89	1.02
31	4.87	5.03	4.65	1.91	7.61	7.87	6.1	6.6	10.16	0.89	1.02
37	4.87	5.03	4.65	1.91	7.61	7.87	6.1	6.6	10.16	0.89	1.02

NOTES:

1. All dimensions are in millimetres.

FIGURE 2.2M - CONNECTORS TYPE – GMR7590

PLUG MALE CONTACTS

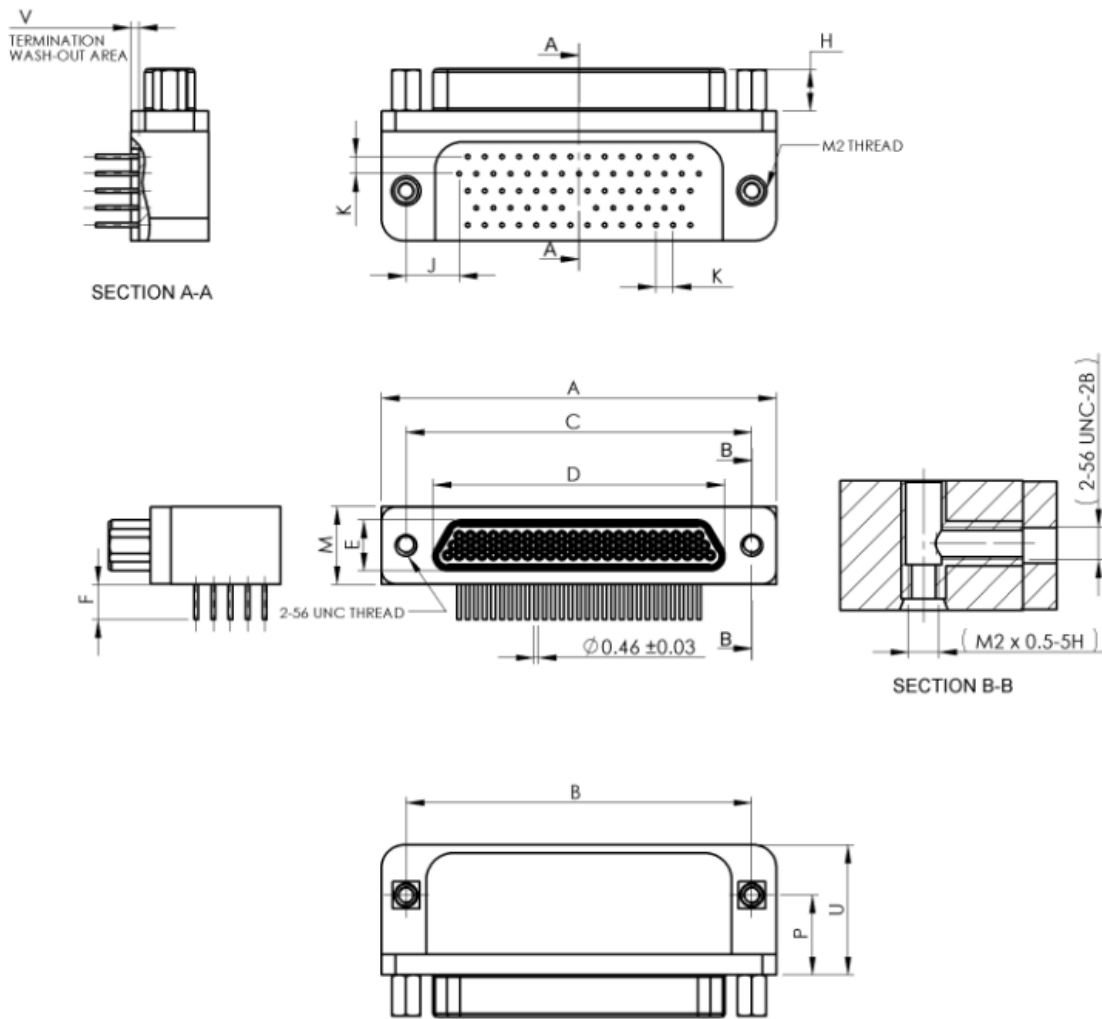

Shell Size	A	B		C		D	E	E	
	Max.	Min.	Max.	Min.	Max.	Max.	Max.	Min.	Max.
51	36.45	30.73	30.99	30.73	30.99	25.02	5.79	4.45	5.21
69	44.07	38.35	38.61	38.35	38.61	32.6	5.79	4.45	5.21

Shell Size	H		J	K	M		P		U	V	
	Min.	Max.	Typ.	Typ.	Min.	Max.	Min.	Max.	Max.	Min.	Max.
51	4.57	4.73	3.05	1.91	8.66	8.92	7.37	7.87	12.45	0.89	1.02
69	4.57	4.73	5.91	1.91	8.66	8.92	8.64	9.14	14.5	0.89	1.02

NOTES:

1. All dimensions are in millimetres.

FIGURE 2.2N - CONNECTORS TYPE – GMR7590
RECEPTACLE FEMALE CONTACTS

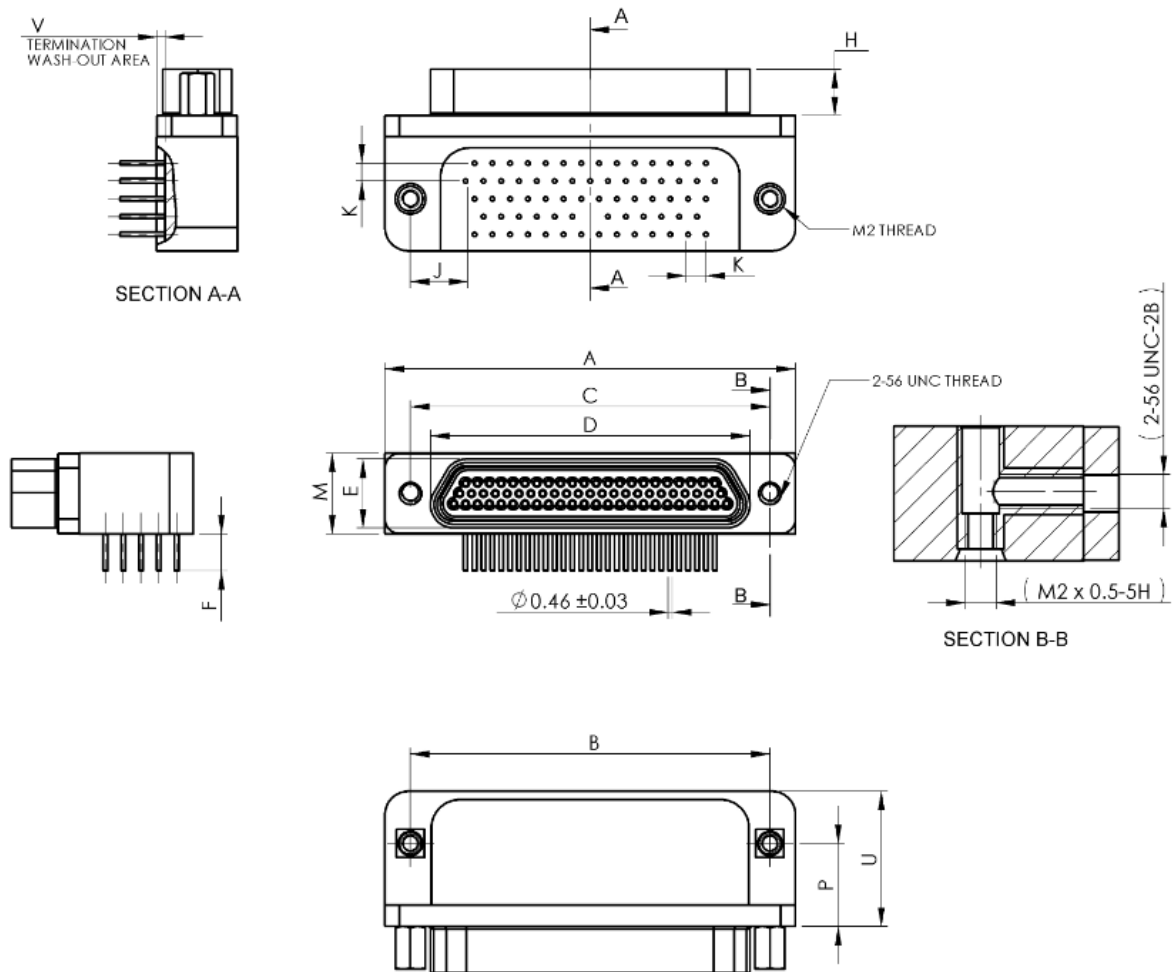

Shell Size	A		B		C		D	E	
	Max.	Min.	Max.	Min.	Max.	Max.	Max.	Min.	Max.
51	36.45	30.73	30.99	30.73	30.99	26.67	7.52	4.45	5.21
69	44.07	38.35	38.61	38.35	38.61	34.24	7.52	4.45	5.21

Shell Size	H		J	K	M		P		U	V	
	Min.	Max.	Typ.	Typ.	Min.	Max.	Min.	Max.	Max.	Min.	Max.
51	4.87	5.03	3.05	1.91	8.66	8.92	7.37	7.87	12.45	0.89	1.02
69	4.87	5.03	5.91	1.91	8.66	8.92	8.64	9.14	14.5	0.89	1.02

NOTES:

1. All dimensions are in millimetres.

FIGURE 2.2P - CONNECTORS TYPE – GMR7590

PLUG MALE CONTACTS

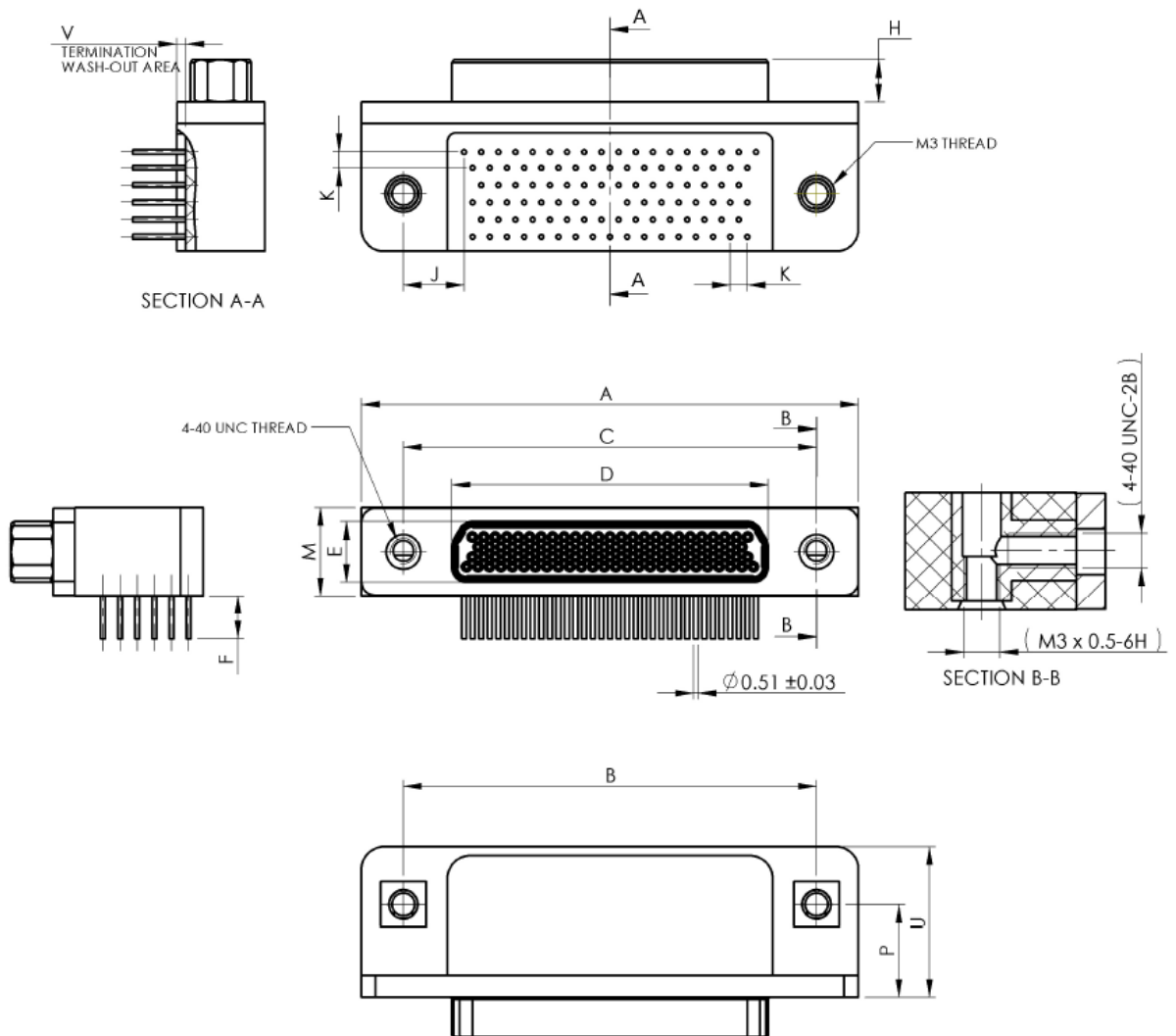

Shell Size	A		B		C		D	E	E	
	Max.	Min.	Max.	Min.	Max.	Max.	Max.	Min.	Max.	
100	55.12	45.59	45.85	45.59	45.85	35.15	6.88	4.45	5.21	

Shell Size	H		J	K	M		P		U	V	
	Min.	Max.	Typ.	Typ.	Min.	Max.	Min.	Max.	Max.	Min.	Max.
100	4.57	4.73	6.68	1.91	9.74	10	9.91	10.41	16.76	0.89	1.02

NOTES:

1. All dimensions are in millimetres.

FIGURE 2.2Q - CONNECTORS TYPE – GMR7590
RECEPTACLE FEMALE CONTACTS

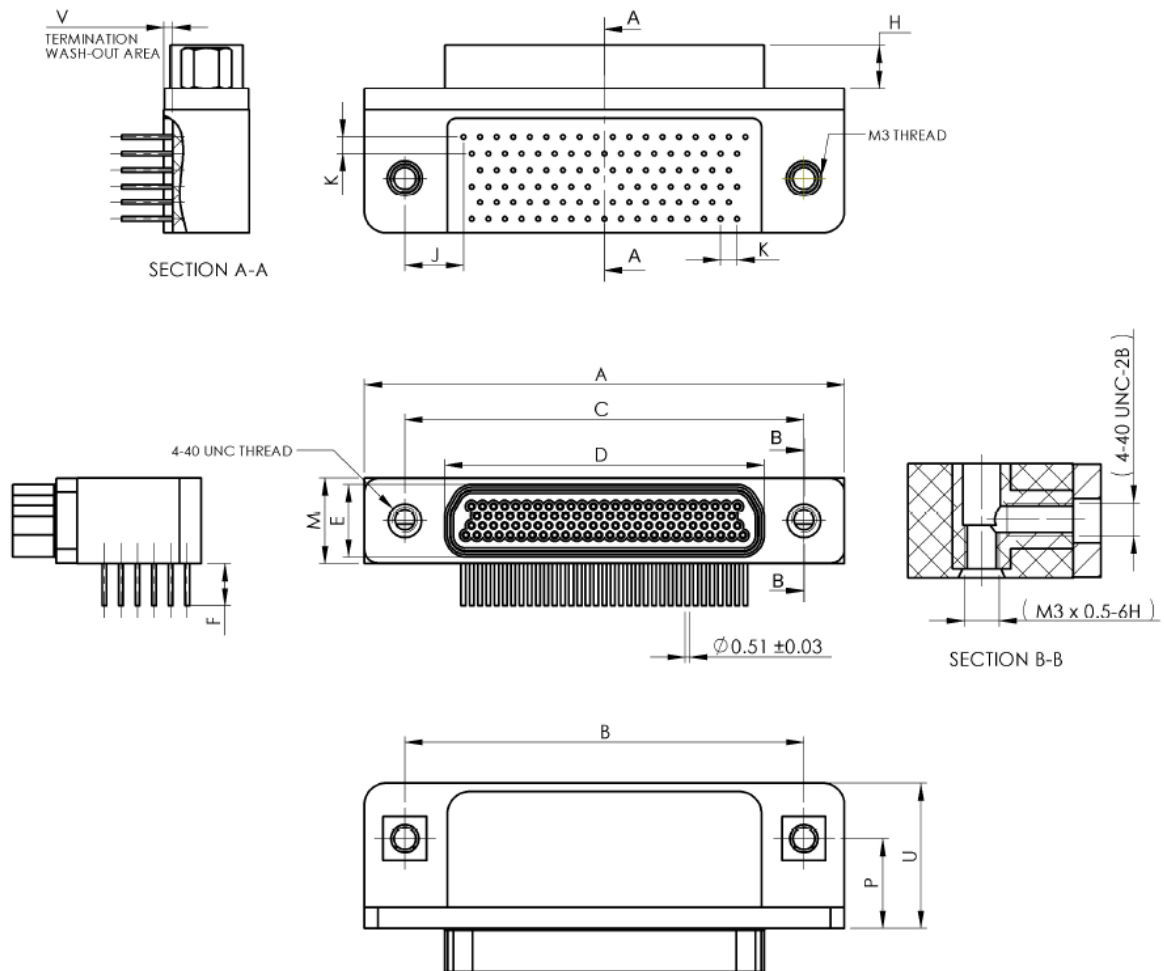

Shell Size	A		B		C		D	E	
	Max.	Min.	Max.	Min.	Max.	Max.	Max.	Min.	Max.
100	55.12	45.59	45.85	45.59	45.85	36.86	10	4.45	5.21

Shell Size	H		J	K	M		P		U	V	
	Min.	Max.	Typ.	Typ.	Min.	Max.	Min.	Max.	Max.	Min.	Max.
100	4.87	5.03	6.68	1.91	9.74	10	9.91	10.41	16.76	0.89	1.02

NOTES:

1. All dimensions are in millimetres.

FIGURE 2.2R - CONNECTORS TYPE – GMR7580

PLUG MALE CONTACTS

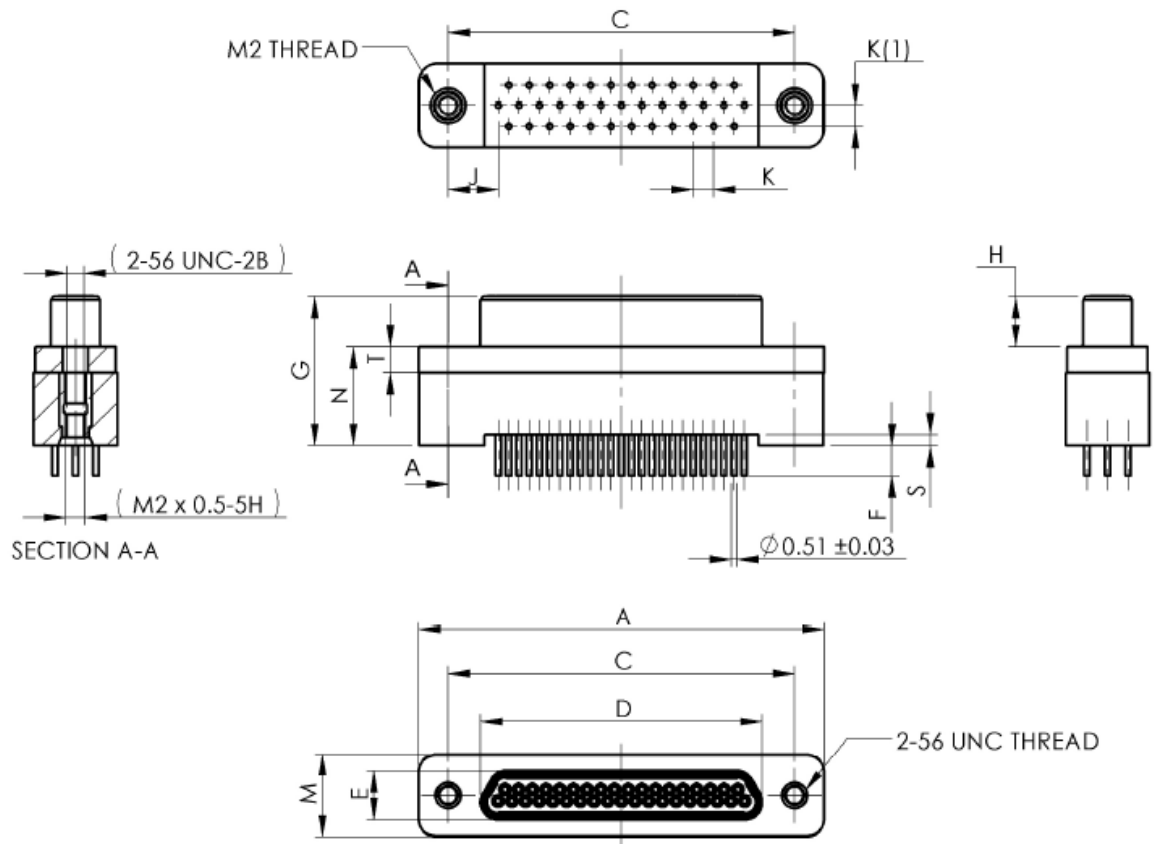

Shell Size	A	C		D	E	E		G	H	
	Max.	Min.	Max.	Max.	Max.	Min.	Max.	Max.	Min.	Max.
9	19.94	14.22	14.48	8.51	4.7	4.45	5.21	13.97	4.57	4.73
15	23.75	18.03	18.29	12.32	4.7	4.45	5.21	13.97	4.57	4.73
21	27.56	21.84	22.1	16.13	4.7	4.45	5.21	13.97	4.57	4.73
25	30.01	24.38	24.64	18.67	4.7	4.45	5.21	13.97	4.57	4.73
31	33.91	28.19	28.45	22.48	4.7	4.45	5.21	13.97	4.57	4.73
37	37.72	32	32.26	26.29	4.7	4.45	5.21	13.97	4.57	4.73

Shell Size	J	K	K(1)	M		<u>N</u>		S	T	
	Typ.	Typ.	Typ.	Min.	Max.	Min.	Max.	Max.	Min.	Max.
9	3.38	1.91	1.91	7.87	8.76	9.02	0.89	1.02	2.34	2.44
15	4.32	1.91	1.91	7.87	8.76	9.02	0.89	1.02	2.34	2.44
21	4.32	1.91	1.91	7.87	8.76	9.02	0.89	1.02	2.34	2.44
25	4.65	1.91	1.91	7.87	8.76	9.02	0.89	1.02	2.34	2.44
31	4.65	1.91	1.91	7.87	8.76	9.02	0.89	1.02	2.34	2.44
37	4.65	1.91	1.91	7.87	8.76	9.02	0.89	1.02	2.34	2.44

NOTES:

1. All dimensions are in millimetres.

FIGURE 2.2S - CONNECTORS TYPE – GMR7580
RECEPTACLE FEMALE CONTACTS

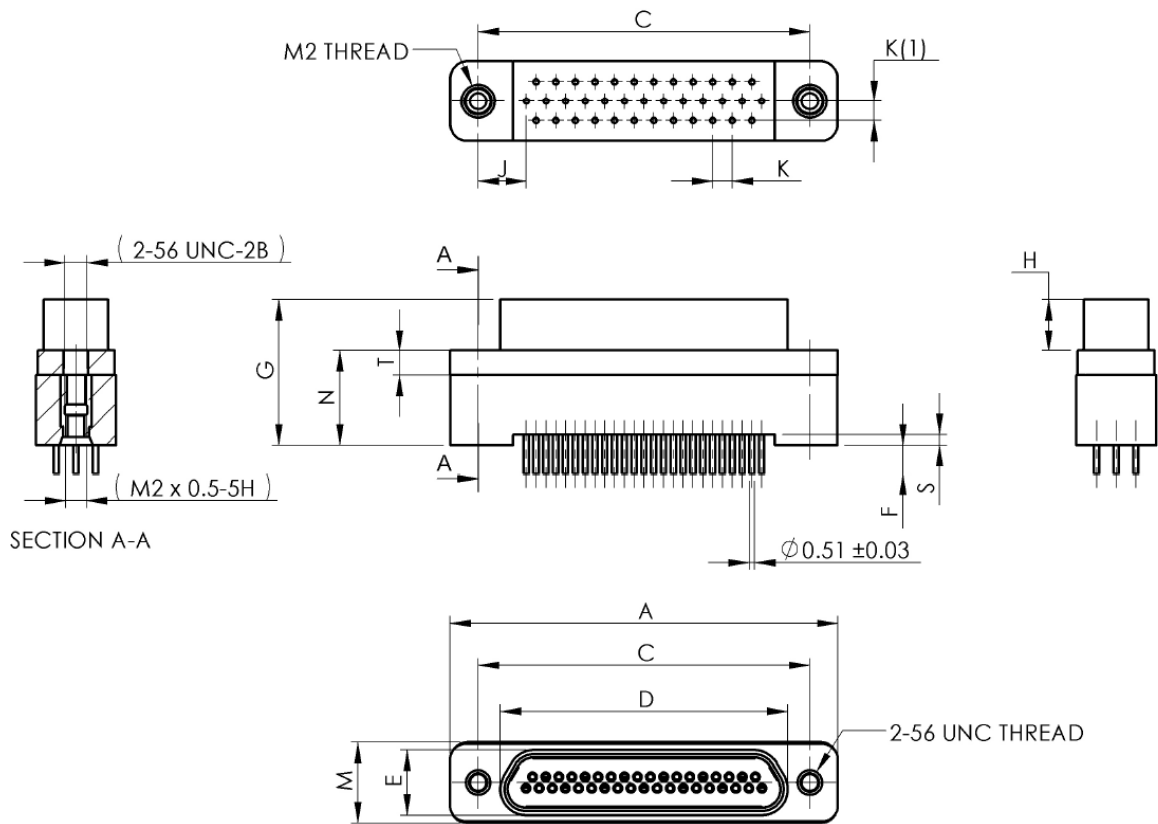

Shell Size	A		C		D	E		G	H	
	Max.	Min.	Max.	Max.	Max.	Min.	Max.		Max.	Min.
9	19.94	14.22	14.48	10.16	6.38	4.45	5.21	14.1	4.87	5.03
15	23.75	18.03	18.29	13.97	6.38	4.45	5.21	14.1	4.87	5.03
21	27.56	21.84	22.1	17.78	6.38	4.45	5.21	14.1	4.87	5.03
25	30.01	24.38	24.64	20.32	6.38	4.45	5.21	14.1	4.87	5.03
31	33.91	28.19	28.45	24.13	6.38	4.45	5.21	14.1	4.87	5.03
37	37.72	32	32.26	27.94	6.38	4.45	5.21	14.1	4.87	5.03

Shell Size	J	K	K(1)	M		N		S		T	
	Typ.	Typ.	Typ.	Min.	Max.	Min.	Max.	Min.	Max.	Min.	Max.
9	3.38	1.91	1.91	7.61	7.87	8.76	9.02	0.89	1.02	2.34	2.44
15	4.32	1.91	1.91	7.61	7.87	8.76	9.02	0.89	1.02	2.34	2.44
21	4.35	1.91	1.91	7.61	7.87	8.76	9.02	0.89	1.02	2.34	2.44
25	4.65	1.91	1.91	7.61	7.87	8.76	9.02	0.89	1.02	2.34	2.44
31	4.65	1.91	1.91	7.61	7.87	8.76	9.02	0.89	1.02	2.34	2.44
37	4.65	1.91	1.91	7.61	7.87	8.76	9.02	0.89	1.02	2.34	2.44

NOTES:

1. All dimensions are in millimetres.

FIGURE 2.2T - CONNECTORS TYPE – GMR7580
PLUG MALE CONTACTS

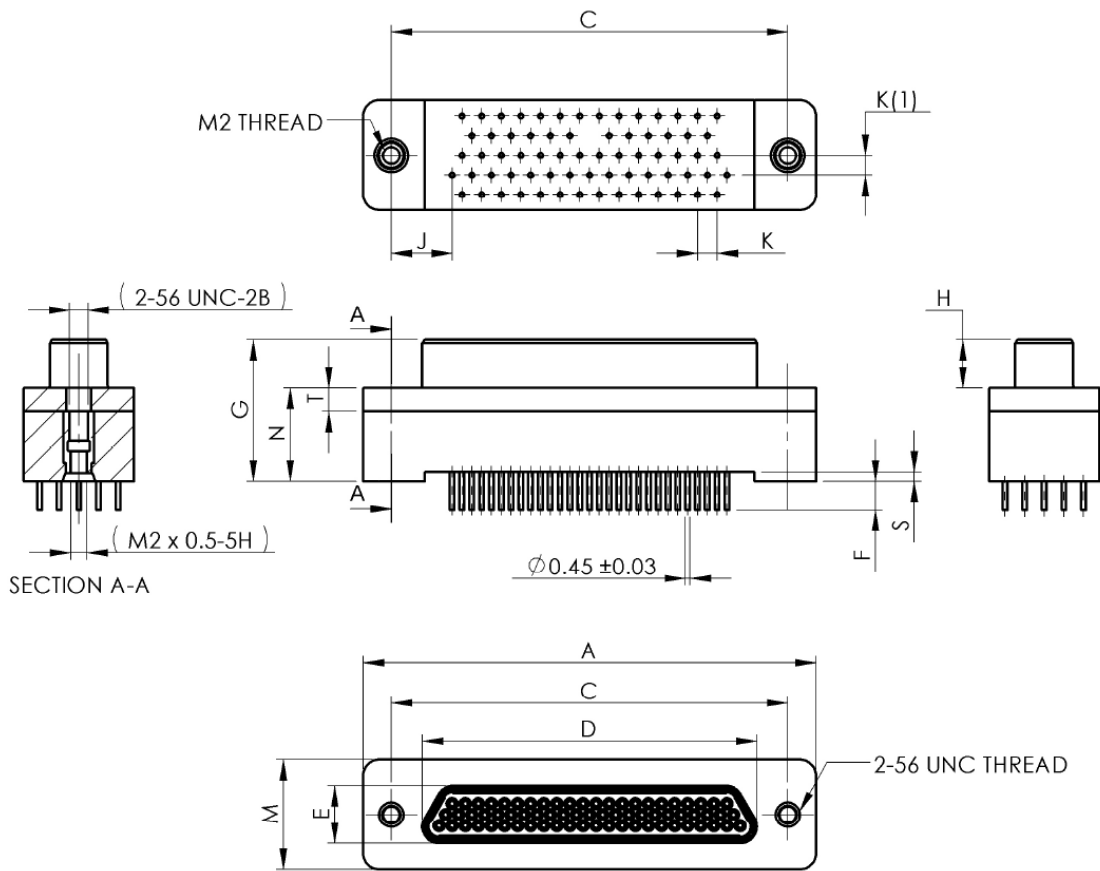

Shell Size	A	C		D	E	E		G	H	
	Max.	Min.	Max.	Max.	Max.	Min.	Max.	Max.	Min.	Max.
51	36.45	30.73	30.99	25.02	5.79	4.45	5.21	13.97	4.57	4.73
69	44.07	38.35	38.61	32.55	5.79	4.45	5.21	13.97	4.57	4.73

Shell Size	J	K	K(1)	M		N		S		T	
	Typ.	Typ.	Typ.	Min.	Max.	Min.	Max.	Min.	Max.	Min.	Max.
51	3.05	1.91	1.91	8.66	8.92	8.76	9.02	0.77	0.9	2.34	2.44
69	5.91	1.91	1.91	10.57	10.83	8.76	9.02	0.77	0.9	2.34	2.44

NOTES:

1. All dimensions are in millimetres.

FIGURE 2.2U - CONNECTORS TYPE – GMR7580
RECEPTACLE FEMALE CONTACTS

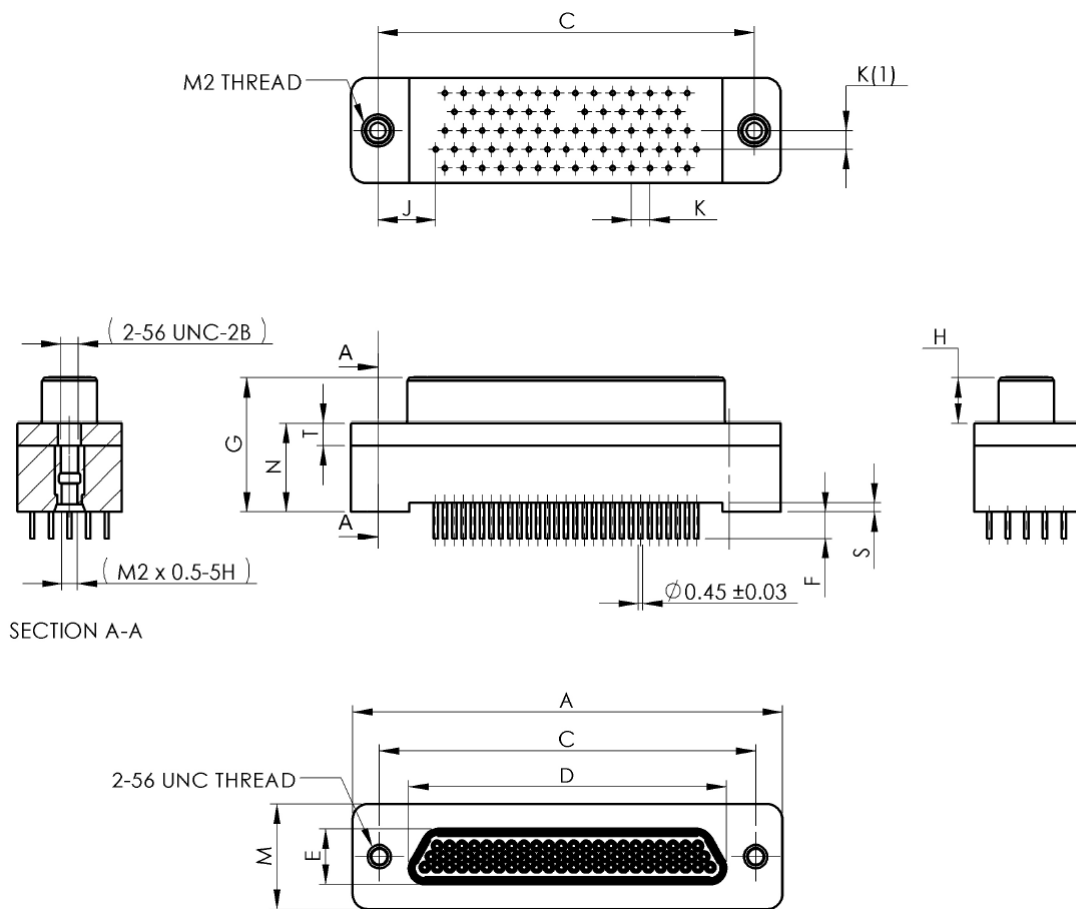

Shell Size	A	C		D	E		G	H		
	Max.	Min.	Max.	Max.	Min.	Max.	Max.	Min.	Max.	
51	36.45	30.73	30.99	26.67	7.52	4.45	5.21	13.97	4.87	5.03
69	44.07	38.35	38.61	34.34	7.52	4.45	5.21	13.97	4.87	5.03

Shell Size	J	K	K(1)	M		N		S		T	
	Typ.	Typ.	Typ.	Min.	Max.	Min.	Max.	Min.	Max.	Min.	Max.
51	3.05	1.91	1.91	8.66	8.92	8.76	9.02	0.77	0.9	2.34	2.44
69	5.91	1.91	1.91	10.54	10.8	8.76	9.02	0.77	0.9	2.34	2.44

NOTES:

1. All dimensions are in millimetres.

FIGURE 2.2V - CONNECTORS TYPE – GMR7580

PLUG MALE CONTACTS

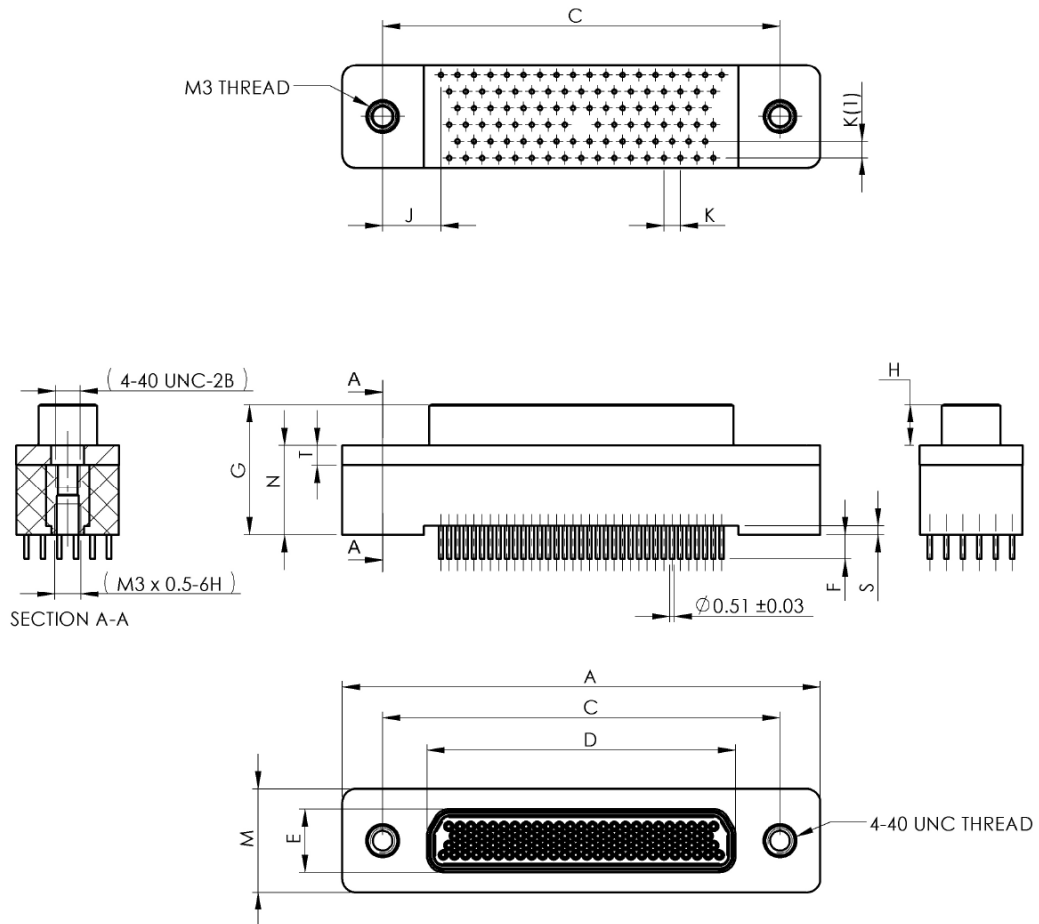

Shell Size	A	C		D	E	E		G	H	
	Max.	Min.	Max.	Max.	Max.	Min.	Max.	Max.	Min.	Max.
100	52.12	45.59	45.85	35.15	6.88	4.45	5.21	15.44	4.58	4.73

Shell Size	J	K	K(1)	M		N		S		T	
	Typ.	Typ.	Typ.	Min.	Max.	Min.	Max.	Min.	Max.	Min.	Max.
100	6.68	1.91	1.91	11.73	11.99	10.66	10.92	0.89	1.02	2.13	2.39

NOTES:

1. All dimensions are in millimetres.

FIGURE 2.2W - CONNECTORS TYPE – GMR7580
RECEPTACLE FEMALE CONTACTS

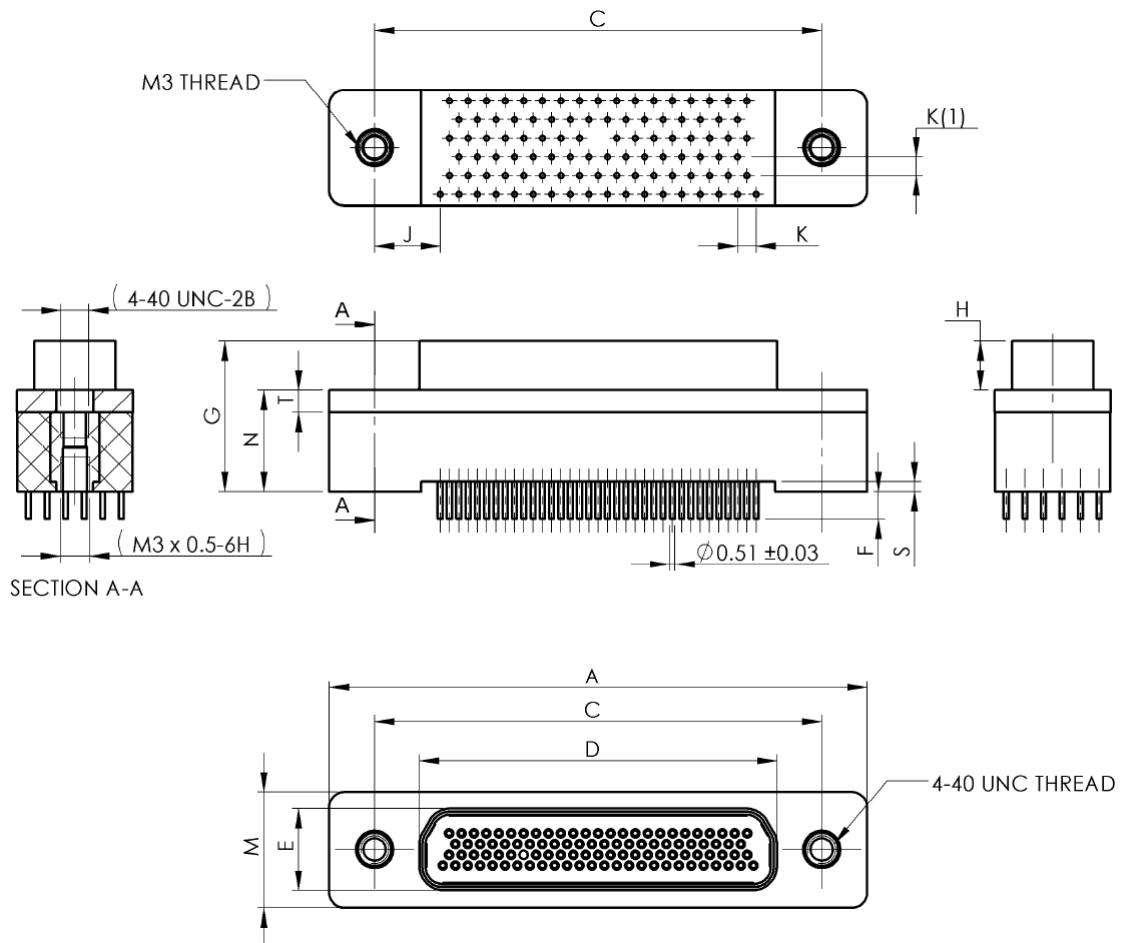

Shell Size	A	C		D	E	E		G	H	
	Max.	Min.	Max.	Max.	Max.	Min.	Max.	Max.	Min.	Max.
100	55.12	45.59	45.85	36.86	8.45	4.45	5.21	15.31	4.87	5.03

Shell Size	J	K	K(1)	M		N		S		T	
	Typ.	Typ.	Typ.	Min.	Max.	Min.	Max.	Min.	Max.	Min.	Max.
100	6.68	1.91	1.91	11.73	11.99	10.79	11.05	0.89	1.02	2.13	2.39

NOTES:

1. All dimensions are in millimetres.

FIGURE 2.3 - CONTACT POSITIONS

FIGURE 2.3.1 - MOUNTING CONDITION

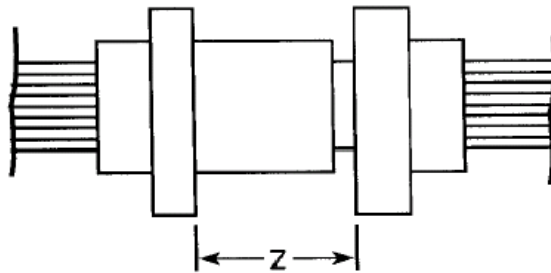

FIGURE 2.3.2 - PLUG MALE CONTACT

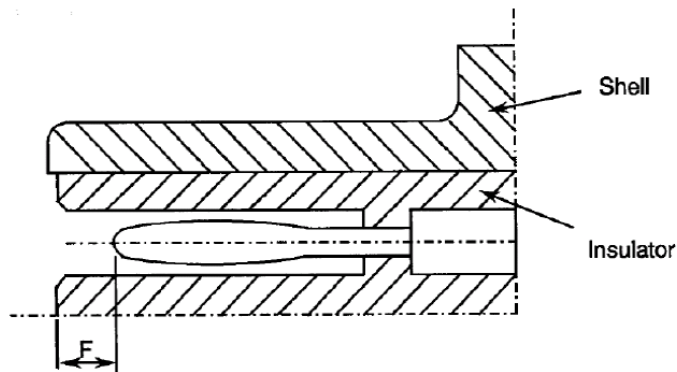
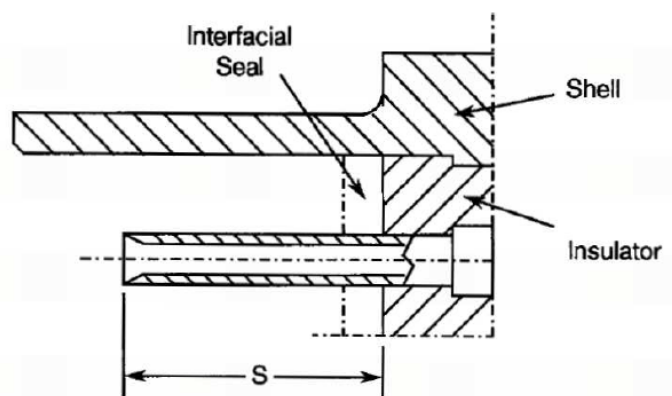
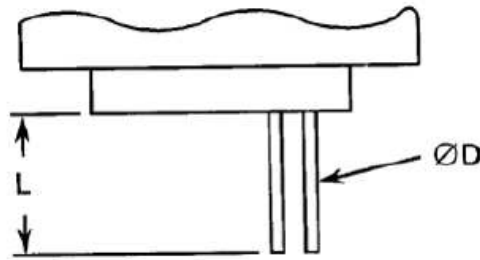

FIGURE 2.3.3 - RECEPTACLE FEMALE CONTACT



F (mm)		S (mm)		Z (mm)
Min	Max	Min	Max	Max
0.25	0.91	3.3	3.66	5.49

FIGURE 2.4 - UNINSULATED SOLID WIRES



Wire Size (AWG)	25
Max Diameter D (mm)	0.46
Min Diameter D (mm)	0.45
Min Gold Plating Thickness (μm)	0.5
Max Weight (g/m)	1.6
Min. Length L	See Para. 4.5.3.3

FIGURE 2.5 - INSULATED WIRES

		ESCC 3901/002		ESCC 3901/013		ESCC 3901/012	
		Wire Size (AWG)					
		26	28	26	28	26	28
Conductor Characteristics	Maximum Diameter (mm)	0.53	0.43	0.5	0.42	0.53	0.38
	Nominal Cross-section (mm^2)	0.15	0.1	0.14	0.1	0.15	0.089
Wire Characteristics	Maximum Diameter (mm)	0.78	0.68	0.89	0.82	0.86	0.7
	Maximum Weight (g/m)	1.93	1.23	2.3	1.8	2.11	1.35
	Colour	Black	Brown	Natural	Natural	Red	White
	Minimum Length	See Para. 4.5.3.3					

FIGURE 2.6 - FLOATING MOUNT

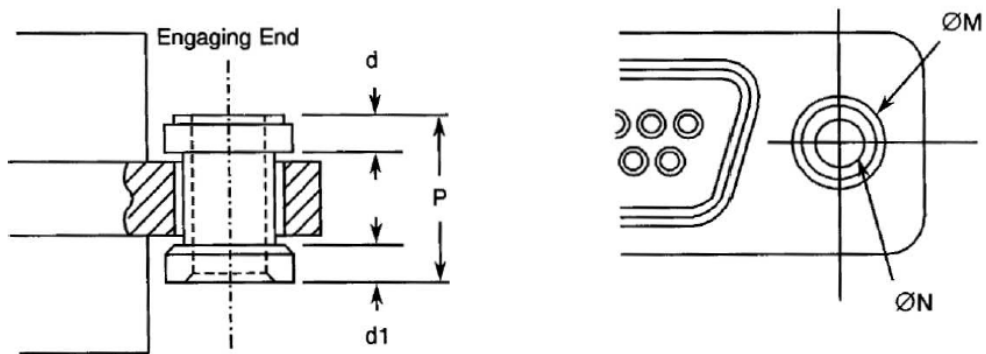

P Max	d	d1	ØM Max	ØN Min
4.7	1.0	0.8	4	2.26

NOTES:

1. All dimensions are in millimetres.
2. Total Lateral Float 0.4 (typical).
3. Total Axial Float 0.4 (typical).

FIGURE 2.7 - CAPTIVE NUT

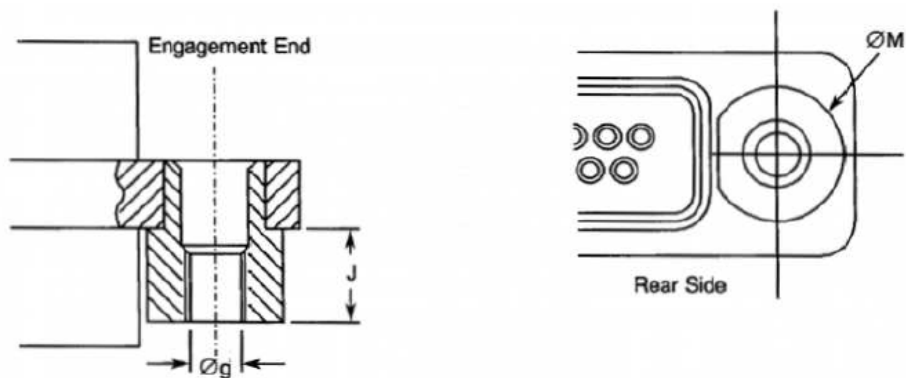

Øg	J Max	ØM Max
Note 2	2.6	5.1

NOTES:

1. All dimensions are in millimetres.
2. Øg: 2-56 UNC 2B, Maximum Torque 0.44Nm.

FIGURE 3 - CONTACT ARRANGEMENTS

FRONT VIEW OF MALE INSERT - USE MIRROR VIEW FOR FEMALE INSERT

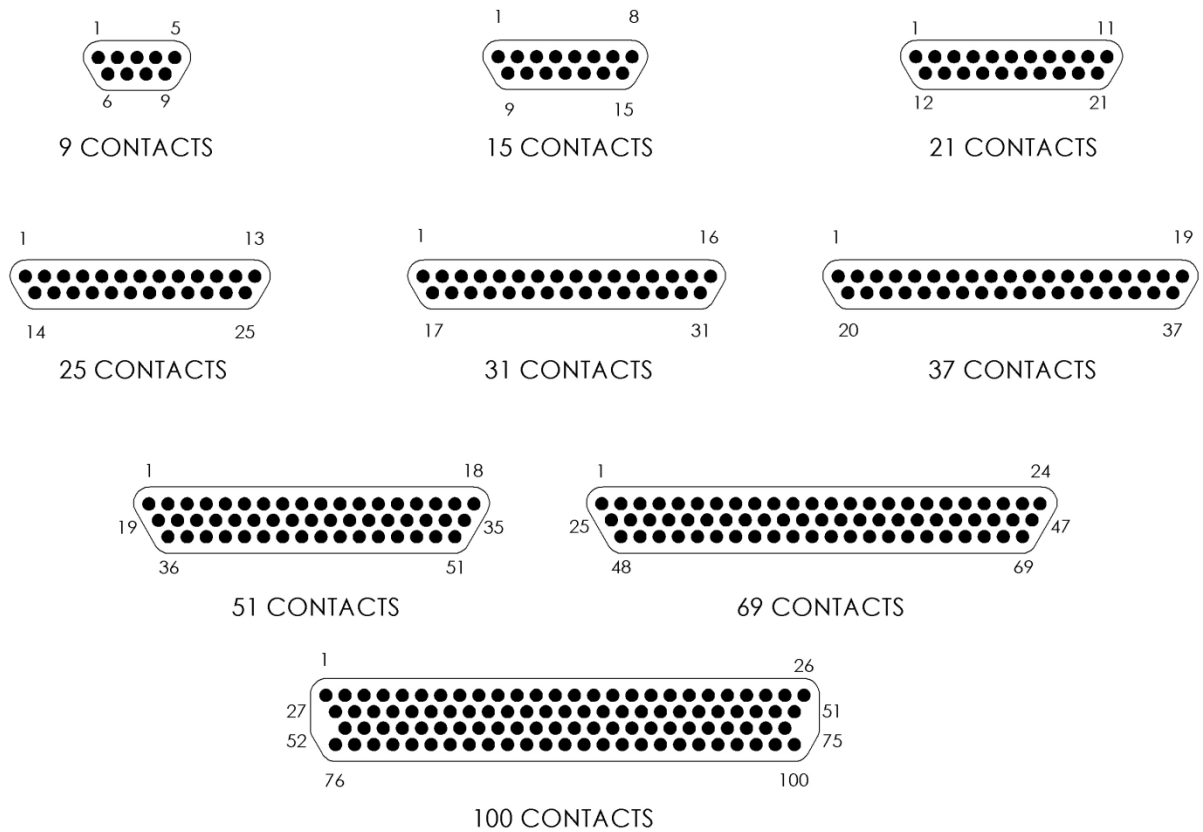

NOTES:

1. Only the outside contact cavities on each row are identified in the drawing, the remainder follow sequentially. Contact numbers are shown outside the insert for readability.

CONTACT CENTRES

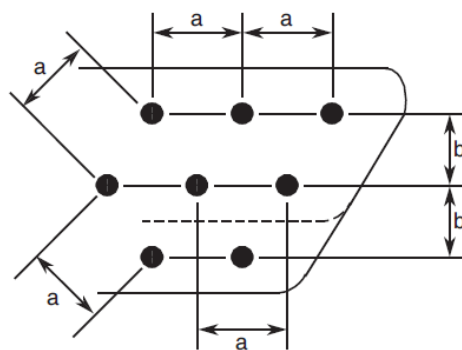

NOTES:

1. a = Distance between contact centres: 1.27mm (typical).
2. b = Distance between rows: 1.09mm (typical).

2 **APPLICABLE DOCUMENTS**

The following documents form part of this specification and shall be read in conjunction with it:

- (a) ESCC Generic Specification No. [3401](#), Connectors, Electrical, Circular and Rectangular.
- (b) ESCC Detail Specification No. [3401/032](#), Accessories for Connectors, Microminiature, [3401/029](#), [3401/077](#) and Connector Savers [3401/041](#).
- (c) ESCC Detail Specification No. [3401/087](#), Lightweight Accessories for Rectangular, Microminiature Connectors, [3401/029](#) and [3401/077](#).
- (d) ESCC Detail Specification No. [3901/002](#), Polyimide Insulated Wires and Cables, Low Frequency, 600V, -100 to +200°C.
- (e) ESCC Detail Specification No. [3901/012](#), Extruded, Cross-linked Fluoropolymer Insulated Wires and Cables on Silver-Plated Copper Conductor, Low Frequency, 600V, -100 to +200°C.
- (f) ESCC Detail Specification No. [3901/013](#), PTFE Insulated Wires and Cables, 600V, -100 to +200°C.
- (g) QQ-W-343, Wire, Electrical, Copper (Uninsulated).
- (h) MIL-DTL-45204, Gold Plating, Electro-deposited.
- (i) SAE-AMS 2418, Copper Plating.
- (j) [MIL-DTL-83513](#), Connectors Electrical, Rectangular, Microminiature, Polarised Shell, General Specification for.

3 **TERMS, DEFINITIONS, ABBREVIATIONS, SYMBOLS AND UNITS**

For the purpose of this specification, the terms, definitions, abbreviations, symbols and units specified in ESCC Basic Specification No. [21300](#) shall apply.

4 **REQUIREMENTS**

4.1 **GENERAL**

The complete requirements for procurement of the connectors specified herein are stated in this specification and ESCC Generic Specification No. [3401](#). Deviations from the Generic Specification, applicable to this specification only, are listed in Para. 4.2.

Deviations from the applicable Generic Specification and this Detail Specification, formally agreed with specific Manufacturers on the basis that the alternative requirements are equivalent to the ESCC requirements and do not affect the components' reliability, are listed in the appendices attached to this specification.

4.2 DEVIATIONS FROM GENERIC SPECIFICATION

4.2.1 Deviations from Special In-Process Controls

Para. 9.15, Joint strength: the contacts shall be crimped to insulated stranded wire AWG26 and AWG28, and to uninsulated solid wire AWG25. The value of failure shall be recorded together with the information as to whether the failure was 'pull-out', 'break in crimp' or 'break in wire'. The minimum tensile strength shall be as follows:

Wire	Male and Female Contacts		
	AWG26	AWG28	AWG25 - Solid Uninsulated
Tensile Strength (N)	22	13	22

4.2.2 Deviations from Final Production Tests (Chart II)

- (a) Para. 9.4, Contact Capability: this test shall be performed on the male contacts. For details see Para. 4.3.3 of this specification.
- (b) Para. 9.5, Magnetism Level: Not applicable.

4.2.3 Deviations from Burn-in and Electrical Measurements (Chart III)

None (Chart III is not applicable).

4.2.4 Deviations from Qualification Tests (Chart IV)

- (a) Para. 9.15, Joint Strength: Not applicable.
- (b) Para. 9.17, Contact Retention (in insert): Not applicable with male contact.
- (c) Para. 9.27, Maintenance Ageing: Not applicable.
- (d) Para. 9.29, Oversize Pin Exclusion: Not applicable.
- (e) Para. 9.30, Probe Damage: Not applicable.
- (f) Para. 9.31, Solderability: Not applicable.

4.2.5 Deviations from Lot Acceptance Tests (Chart V)

- (a) Para. 9.15, Joint Strength: Not applicable.
- (b) Para. 9.17, Contact Retention (in insert): Not applicable with male contact.
- (c) Para. 9.27, Maintenance Ageing: Not applicable.
- (d) Para. 9.29, Oversize Pin Exclusion: Not applicable.
- (e) Para. 9.30, Probe Damage: Not applicable.

4.3 MECHANICAL REQUIREMENTS

4.3.1 Dimension Check

The dimensions of the connectors specified herein shall be verified in accordance with the requirements set out in Para. 9.6 of ESCC Generic Specification No. 3401 and shall conform to those shown in Figure 2 of this specification. Only the underlined dimensions shall be checked during procurement.

4.3.2 Weight

The maximum weight of the connectors specified herein shall be calculated on the basis of, and be in accordance with the values given in Table 1(a) and in Figures 2.4 and 2.5 of this specification.

4.3.3 Contact Capability

For the purpose of this test, the pick-up and drop weights shall be as follows.

Measurements	Pick-Up Weight	Drop Weight
Weight (g)	14	170
Inner Gauge Diameter (mm) (1)	0.582 - 0.587	0.559 - 0.564
Insertion Depth (mm)	1.5	1.5

NOTES:

1. See Figure 4 for ØA.

4.3.4 Contact Retention (in Insert)

Contact retention within the insert shall be 22.25 Newtons. There shall be no displacement of the contact. Not applicable to male contacts.

4.3.5 Mating and Unmating Forces

The forces applied for the mating and unmating of the connectors shall conform to the values specified in Table 1(a).

4.3.6 Insert Retention (in Shell)

Connector inserts shall withstand a pressure of 34.4N/cm² applied from the mating side to the rear side.

4.3.7 Jackscrew Retention

Not applicable.

4.3.8 Contact Insertion and Withdrawal Forces

Not applicable.

4.3.9 Engagement and Separation Forces (Male Contacts)

The contact engagement and separation forces of the male contacts shall be tested to a depth of 1.5mm with the applicable test gauge fixtures specified in Figure 4 of this specification, and shall not exceed the values of the table hereunder.

Measurements	Inner Diameter (mm)		Separation Force Min. (N)	Engagement Force Max. (N)
	Min.	Max.		
Max. Gauge Fixture	0.559	0.564	-	1.667
Min. Gauge Fixture	0.582	0.587	0.137	-

4.3.10 Oversize Pin Exclusion

Not applicable.

4.3.11 Probe Damage

Not applicable.

4.3.12 Solderability

Not applicable.

4.4 MATERIALS AND FINISHES

The materials and finishes shall be as specified herein. Where a definite material is not specified, a material which will enable the components specified herein to meet the performance requirements of this specification shall be used. Acceptance or approval of any constituent material does not guarantee acceptance of the finished product.

4.4.1 Shells

Shells shall be made of aluminium alloy. Variant 01 shall have a minimum plating thickness of 25.4µm of electroless nickel. The plating for Variant 02 shall be 0.7µm minimum of gold with 25.4µm minimum of electroless nickel underplating.

4.4.2 Inserts

Inserts shall be made of glass fibre-filled diallylphthalate resin or suitable thermoplastic material.

4.4.3 Contacts

4.4.3.1 *Female Contacts*

The contact body material and finish shall either be copper alloy with an underplate of 1µm minimum of copper to SAE-AMS 2418, gold plated with 1.27µm minimum of gold Type 2 Grade C of MIL-DTL-45204, or Type N2 with underplating in accordance with Para 3.3 note 3(b) of ESCC Basic Specification No. [23500](#). Measurement of thickness shall be performed at a distance of 1.5mm from the engagement end.

4.4.3.2 *Male Contacts*

The contact body and the bundle material and finish shall either be copper alloy with an underplate of 1µm minimum of copper to SAE-AMS 2418, gold plated with 1.27µm minimum of gold Type 2 Grade C of MIL-DTL-45204, or Type M2 with underplating in accordance with Para 3.3 note 3(b) of ESCC Basic Specification No. [23500](#). Measurement of thickness shall be performed at a distance of 1.5mm from the engagement end.

4.4.4 Interfacial Seals

Interfacial seals shall be made of silicon base rubber.

4.4.5 Insulated Wires

Wire materials and finishes shall be in accordance with the requirements specified in Para. 4.4 of ESCC Detail Specifications No. [3901/002](#), [3901/012](#) and [3901/013](#).

4.4.6 Uninsulated Solid Wire

Uninsulated solid wire material and finish shall either be copper alloy in accordance with Type S as specified in QQ-W-343, gold-plated in accordance with Class ØØ Grade C or D as specified in MIL-DTL-45204, or Type A14 (except the thickness of the gold-plating shall be 0.25µm minimum) in accordance with ESCC Basic Specification No. [23500](#).

4.4.7 Rear Potting

Rear potting shall be made of epoxy resin. For connectors Type FR136, Type FR136A and Type FR139, the rear container shall be made from glass-fibre filled diallylphthalate resin or suitable thermoplastic material.

4.5 MARKING

4.5.1 General

The marking of all components delivered to this specification shall be in accordance with the requirements of ESCC Basic Specification No. 21700 and the following paragraphs.

Each component shall be marked in respect of:

- (a) The ESCC Component Number.
- (b) Characteristics.
- (c) Traceability Information.

4.5.2 The ESCC Component Number

Each component shall bear the ESCC Component Number which shall be constituted and marked as follows:

340102901B

- Detail Specification Number: 3401029
- Type Variant (See Table 1(a)): 01
- Testing Level: B

4.5.3 Characteristics

The characteristics to be marked in the following order of precedence are:

- (a) Shell Size.
- (b) Contact Type.
- (c) Termination Type.
- (d) Mounting.

The information shall be constituted and marked as follows:

Example: 51PFR112F

- Shell size: 51
- Contact type: P
- Termination Type: FR112
- Mounting: F

4.5.3.1 *Shell Size*

Shell size shall be designated by the number of contacts.

Specified numbers are: 9, 15, 21, 25, 31, 37, 51, 69 and 100.

4.5.3.2 *Contact Type*

Contact types shall be indicated by the following code letters.

Code Letter	Contact Type
P	Male
S	Female

4.5.3.3 Termination Type

Codes defining the termination type and details according to Figures 2.1, 2.2, 2.4 and 2.5 as follows:

Code	Type	Min. Length (mm)
FR112	AWG26 Wire 390101302B	508
FR112A	AWG26 Wire 390100256B	508
FR112B	AWG26 Wire 390101203B	508
FR113	AWG26 Wire 390101302B	914
FR113A	AWG26 Wire 390100256B	914
FR113B	AWG26 Wire 390101203B	914
FR123	AWG26 Wire 390101302B	4000
FR123A	AWG26 Wire 390100256B	4000
FR123B	AWG26 Wire 390101203B	4000
FR114	AWG28 Wire 390101301B	508
FR114A	AWG28 Wire 390100261B	508
FR114B	AWG28 Wire 390101202B	508
FR115	AWG28 Wire 390101301B	914
FR115A	AWG28 Wire 390100261B	914
FR115B	AWG28 Wire 390101202B	914
FR116	Uninsulated Wire	25.4
FR136 FR136A	90° Mounting on PCB, 2.54mm PCB termination pitch	-
FR139	Straight Mounting on PCB, 2.54mm PCB termination pitch	-
GMR7590	Uninsulated wire formed for 90° Mounting on PCB, 1.91 mm PCB termination pitch	-
GMR7580	Uninsulated wire formed for Straight Mounting on PCB, 1.91 mm PCB termination pitch	-

4.5.3.4 Mounting

The letter E indicates a captive nut.

The letter F shall indicate a floating mount.

If the shell has fixed mounting holes, these letters shall be omitted.

4.5.4 Traceability Information

Traceability information shall be marked in accordance with the requirements of ESCC Basic Specification No. [21700](#).

4.6 ELECTRICAL MEASUREMENTS

4.6.1 Electrical Measurements at Room Temperature

The parameters to be measured in respect of electrical characteristics are scheduled in Table 2. Unless otherwise specified, the measurements shall be performed at $T_{amb} = +22 \pm 3^{\circ}C$.

4.6.2 Electrical Measurements at High and Low Temperatures

Not applicable.

4.6.3 Circuits for Electrical Measurements

Not applicable.

4.7 BURN-IN AND ELECTRICAL MEASUREMENTS (TABLES 4 AND 5)

Not applicable.

TABLE 2 - ELECTRICAL MEASUREMENTS AT ROOM TEMPERATURE

No.	Characteristic	Symbol	ESCC 3401 Test Method	Test Condition	Limits		Unit
					Min	Max	
1	Insulation Resistance	R_i	Para. 9.1.1.1	Para. 9.1.1.1	5000	-	$M\Omega$
2	Voltage Proof Leakage Current	I_L	Para. 9.1.1.2	600Vrms	-	2	mA
3	Mated Shell Conductivity (Voltage Drop) (Note 1)	V_D	Para. 9.1.1.4	Para. 9.1.1.4	Not applicable		mV
4	Contact Resistance (Low Level Current)	$R_{cl} \text{ max.}$	Para. 9.1.1.3	Para. 9.1.1.3	-	6 (2) 25 (3)	$m\Omega$
5	Contact Resistance (Rated Current)	$R_{cr} \text{ max.}$	Para. 9.1.1.3	Table 1(b)	-	5 (2) 25 (3)	$m\Omega$

NOTES:

1. Applicable to mated connectors with grounding option.
2. For all termination types except FR136, FR136A, FR139.
3. For termination types FR136, FR136A, FR139. Measurement of Contact Resistance shall include all parts of the contact including the body and the wire.

TABLES 3, 4 AND 5

Not applicable.

FIGURE 4 - GAUGE FIXTURE

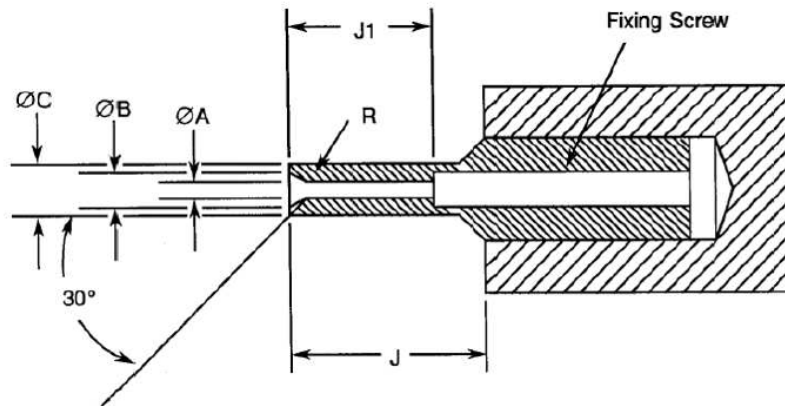

MAXIMUM GAUGE

Weight (g) 170			Remarks
Symbol	Min.	Max.	
ØA	0.559	0.564	Note 2
ØB	0.749	0.775	-
ØC	0.813	0.825	-
J	4	-	-
J1	3.13	3.23	-
R	0.381	0.483	Note 1

MINIMUM GAUGE

Weight (g) 14			Remarks
Symbol	Min.	Max.	
ØA	0.582	0.587	Note 2
ØB	0.749	0.775	-
ØC	0.813	0.825	-
J	4	-	-
J1	3.13	3.23	-
R	0.381	0.483	Note 1

NOTES:

1. Radius R, must be tangent to entry chamfer and ØA.
2. ØA and entry chamfer shall have a surface roughness of 3.2µm (roughness grade N8).
3. All dimensions are in millimetres.

- 4.8 ENVIRONMENTAL AND ENDURANCE TESTS (CHARTS IV AND V OF ESCC GENERIC SPECIFICATION No. 3401)
- 4.8.1 Measurements and Inspections on Completion of Environmental Tests
The parameters to be measured and inspections to be performed on completion of environmental testing shall be those specified in Table 6. Unless otherwise specified, these measurements shall be performed at $T_{amb} = +22 \pm 3^{\circ}\text{C}$.
- 4.8.2 Measurements and Inspections at Intermediate Points during Endurance Tests
Not applicable.
- 4.8.3 Measurements and Inspections on Completion of Endurance Tests
The parameters to be measured and inspections to be performed on completion of endurance testing shall be those specified in Table 6. Unless otherwise specified, these measurements shall be performed at $T_{amb} = +22 \pm 3^{\circ}\text{C}$.
- 4.8.4 Conditions for Operating Life Test (Part of Endurance Testing)
Not applicable.
- 4.8.5 Electrical Circuit for Operating Life Test
Not applicable.
- 4.8.6 Conditions for High Temperature Storage Test (Part of Endurance Testing)
The requirements for the high temperature storage test are specified in Section 9 of ESCC Generic Specification No. 3401. The temperature to be applied shall be the maximum storage temperature specified in Table 1(b) of this specification.

TABLE 6 - MEASUREMENTS AND INSPECTIONS ON COMPLETION OF ENVIRONMENTAL AND ENDURANCE TESTING

No.	ESCC Generic Spec. No. 3401		Measurements and Inspections		Symbol	Limits		Unit
	Environmental and Endurance Tests Note 1	Test Method and Conditions	Identification	Conditions		Min	Max	
01	Seal Test	Para. 9.9	ESCC 3401 Para. 9.9	-	-	Not applicable		-
02	Wiring	Para. 9.10	Low Level Contact Resistance	Table 2 Item 4	R _{cl}	Table 2, Item 4		-
03	Vibration	Para. 9.11	Initial Measurements Coupling screw(s) Unlocking Torque	-	T _{qe}	Record Values		-
			Final Measurements Full Engagement Coupling screw(s) Unlocking Torque Drift Visual Examination	-	ΔT _{qe} /T _{qe}	-25	+25	%
04	Shock or Bump	Para. 9.12	Full Engagement Visual Examination	-	-	-	-	-
05	Climatic Sequence	Para. 9.13	Dry Heat Insulation Resistance	At High Temperature Table 2, Item 1 (2)	R _i	10	-	MΩ
			Low Air Pressure Voltage Proof Leakage Current	Figure 1	I _L	ESCC 3401 Para. 9.13.5		mA
			Damp Heat Insulation Resistance	Immediately after test Table 2, Item 1	R _i	100	-	MΩ
			Final Measurements External Visual Inspection Insulation Resistance Voltage Proof Leakage Current	After 1-24 hrs Recovery ESCC 3401 Para. 9.7 Table 2, Item 1 Table 2, Item 2	- R _i I _L	ESCC 3401 Para. 9.7 Table 2, Item 1 Table 2, Item 2	- MΩ mA	
06	Plating Thickness	Para. 9.14	Thickness	-	-	Para. 4.4.3 of this spec.		-
07	Joint Strength (N/A to solder contacts)	Para. 9.15	ESCC 3401 Para. 9.15	-	-	Not applicable		-
08	Rapid Change of Temperature	Para. 9.16	Visual Examination	-	-	-		-
			Insulation Resistance Voltage Proof Leakage Current	Table 2, Item 1 Table 2, Item 2	R _i I _L	Table 2, Item 1 Table 2, Item 2	MΩ mA	
09	Contact Retention (in Insert)	Para. 9.17 & Para. 4.3.4 of this spec.	Contact Displacement	-	-	ESCC 3401 Para. 9.17		-

No.	ESCC Generic Spec. No. 3401		Measurements and Inspections		Symbol	Limits		Unit
	Environmental and Endurance Tests Note 1	Test Method and Conditions	Identification	Conditions		Min	Max	
10	Endurance	Para. 9.18	Initial Measurements Mating/Unmating Forces Low Level Contact Resistance Mated Shell Conductivity Final Measurements Visual Examination Mating/Unmating Forces Low Level Contact Resistance Drift Rated Current Contact Resistance Mated Shell Conductivity Insulation Resistance Voltage Proof Leakage Current	- Table 2, Item 4 Table 2, Item 3 - - Table 2, Item 4 Table 2, Item 5 Table 2 Item 3 Table 2 Item 1 Table 2 Item 2	F R _{cl} V _D - F ΔR _{cl} R _{cr} V _D R _i I _L	Para. 4.3.5 of this spec. Record Values Not applicable - - Para. 4.3.5 of this spec - 3 Table 2, Item 5 Not applicable Table 2, Item 1 Table 2, Item 2	N mΩ mV N mΩ mΩ mV MΩ mA	
11	Permanence of Marking	Para. 9.19	-	-	-	-	-	-
12	Mating/Unmating Forces	Para. 9.20	Force	-	F	Para. 4.3.5 of this spec	N	
13	High Temperature Storage	Para. 9.21	Initial Measurements Low Level Contact Resistance Mated Shell Conductivity Final Measurements Visual Examination Mating/Unmating Forces Low Level Contact Resistance Drift Rated Current Contact Resistance Mated Shell Conductivity Insulation Resistance Voltage Proof Leakage Current Contact Retention (In insert)	Table 2, Item 4 Table 2, Item 3 - - Table 2, Item 4 Table 2, Item 5 Table 2 Item 3 Table 2 Item 1 Table 2 Item 2 Para. 4.3.4 of this spec.	R _{cl} V _D - F ΔR _{cl} R _{cr} V _D R _i I _L -	Record Values Not applicable - Para. 4.3.5 of this spec - 3 Table 2, Item 5 Not applicable Table 2, Item 1 Table 2, Item 2 ESCC 3401 Para. 9.17	mΩ mV N mΩ mΩ mV MΩ mA -	
14	Corrosion	Para. 9.22	Visual Examination	-	-	-	-	-

No.	ESCC Generic Spec. No. 3401		Measurements and Inspections		Symbol	Limits		Unit
	Environmental and Endurance Tests Note 1	Test Method and Conditions	Identification	Conditions		Min	Max	
15	Insert Retention (in Shell)	Para. 9.23 & Para. 4.3.6 of this spec.	Visual Examination	-	-	Para. 4.3.6 of this spec.		-
16	Jackscrew Retention	Para. 9.24 & Para. 4.3.7 of this spec.	Visual Examination	-	-	Not applicable		-
17	High Temperature Measurements	Para. 9.25	Insulation Resistance	Table 2 Item 1 (2)	R _i	10	-	MΩ
18	Overload Test	Para. 9.26	Internal Temperature	-	T	-	+100	°C
			Rated Current Contact Resistance	Table 2, Item 5	R _{cr}	Table 2, Item 5		mΩ
			Mated Shell Conductivity	Table 2 Item 3	V _D	Not applicable		mV
			Insulation Resistance	Table 2 Item 1	R _i	Table 2, Item 1		MΩ
			Voltage Proof Leakage Current	Table 2 Item 2	I _L	Table 2, Item 2		mA
19	Maintenance Ageing	Para. 9.27	Visual Examination Contact Retention (in Insert)	- Para. 4.3.4 of this spec.	- -	- Not applicable	- -	- N
20	Engage/Separation Forces	Para. 9.28 & Para. 4.3.9 of this spec.	Force	-	F	Para. 4.3.9 of this spec.		N
21	Oversize Pin Exclusion	Para. 9.29 & Para. 4.3.10 of this spec.	Not applicable	-	-	-	-	-
22	Probe Damage	Para. 9.30 & Para. 4.3.11 of this spec.	Not applicable	-	-	-	-	-
23	Solderability	Para. 9.31 & Para. 4.3.12 of this spec.	Not applicable	-	-	-	-	-

NOTES:

1. The tests in this Table refer to either Chart IV or V and shall be used as applicable.
2. T_{amb} = +125°C.

APPENDIX 'A'
AGREED DEVIATIONS FOR C & K COMPONENTS (F)

ITEMS AFFECTED	DESCRIPTION OF DEVIATIONS
Para. 4.2.2, Deviations from Final Production Tests (Chart II)	Para. 9.4, Contact Capability: 100% Contact Capability Test may be omitted provided that a 100% visual inspection of the contacts is performed on each batch submitted to tests defined in the C&K PID requirements.