



THE ESCC DOCUMENTATION SYSTEM

ESCC 12001

Issue 3	February 2015
---------	---------------



Document Custodian: European Space Agency – see <https://escies.org>

LEGAL DISCLAIMER AND COPYRIGHT

European Space Agency, Copyright © 2015, All rights reserved.

The European Space Agency disclaims any liability or responsibility, to any person or entity, with respect to any loss or damage caused, or alleged to be caused, directly or indirectly by the use and application of this ESCC publication.

This publication, without prior permission of the European Space Agency and provided it is not used for a commercial purpose, may be:

- copied in whole, in any medium, without alteration or modification.
- copied in part, in any medium, provided that the ESCC document identification, comprising the ESCC symbol, document number and document issue, is removed.

DOCUMENTATION CHANGE NOTICE

(Refer to <https://escies.org> for ESCC DCR content)

DCR No.	CHANGE DESCRIPTION
907	Document upissued to incorporate editorial DCR. Specification produced in MSWORD. Changes in presentation are possible.

TABLE OF CONTENTS

1	INTRODUCTION	6
2	SCOPE	6
3	DEFINITIONS AND ABBREVIATIONS	6
3.1	DEFINITIONS	6
3.2	ABBREVIATIONS	6
4	RELATED DOCUMENTS	7
4.1	APPLICABLE DOCUMENTS	7
4.2	REFERENCE DOCUMENTS	7
5	RESPONSIBILITIES	7
5.1	SCSB	7
5.2	PSWG	7
5.3	EXECUTIVE	8
5.4	ESCC SECRETARIAT	8
5.5	DOCUMENTATION SYSTEM USERS	8
6	ESCC DOCUMENTATION ARCHITECTURE	9
6.1	DESCRIPTION	9
6.2	DOCUMENTATION ARCHITECTURE – OVERVIEW	10
6.3	LEVEL 0 DOCUMENTS	10
6.4	LEVEL 1 DOCUMENTS – ORGANISATION	11
6.5	LEVEL 1 DOCUMENTS - SUPPORT	11
6.6	LEVEL 1 DOCUMENTS - IMPLEMENTATION	11
6.7	LEVELS 2, 3 AND 4 DOCUMENTS – SPECIFICATIONS	12
7	CODING OF ISSUED DOCUMENTS AND SPECIFICATIONS	12
7.1	GENERAL	12
7.2	LEVEL 0 DOCUMENTS	13
7.3	LEVEL 1 DOCUMENTS	13
7.4	LEVEL 2 SPECIFICATIONS (BASIC)	13
7.5	LEVEL 3 SPECIFICATIONS (GENERIC)	14
7.6	LEVEL 4 SPECIFICATIONS (DETAIL)	14
8	CODING OF DRAFT DOCUMENTS AND SPECIFICATIONS	14
9	ISSUE STATUS	14
9.1	GENERAL	14
9.2	ISSUED DOCUMENTS AND SPECIFICATIONS	14
9.3	DRAFT DOCUMENTS AND SPECIFICATIONS	15
10	REPORTS, WORKING PAPERS AND ADMINISTRATIVE DOCUMENTATION	15
10.1	DOCUMENTATION TYPES	15

10.2	REPORTS	16
10.3	WORKING PAPERS	16
10.4	AGENDAS AND MINUTES	17
11	AVAILABILITY OF ESCC DOCUMENTS AND SPECIFICATIONS	17
12	RESPONSIBILITY FOR THE PREPARATION OF ESCC DOCUMENTS AND SPECIFICATIONS	17
13	CONFIGURATION CONTROL OF ESCC DOCUMENTS AND SPECIFICATIONS	17
14	RECORDS AND REPORTING	17

1 **INTRODUCTION**

This document specifies the architecture of the ESCC Documentation and Specification System.

The activities of ESCC result, inter alia, in a formal set of documents which are made freely and publicly available. These encompass ESCC procedures, dealing with the operation of the system, and ESCC component specifications. However, the content is so structured that the specifications may be utilised without recourse to the procedures. This separates the practical aspects for users concerning the definition, qualification and procurement of components from the ESCC policy making, administration and operation.

In addition this document specifies the structure and identification used for the handling of the working documents, draft papers and reports generated and used by the Organisational Bodies within the ESCC.

2 **SCOPE**

This document applies to the ESCC Organisational Bodies responsible for the preparation of ESCC Documents and Specifications and the custody and management of the ESCC Specification System. It also acts as a reference document for users of the published ESCC documentation.

3 **DEFINITIONS AND ABBREVIATIONS**

3.1 **DEFINITIONS**

None.

3.2 **ABBREVIATIONS**

The following abbreviations are used in this document:

Charter	Charter of the European Space Components Coordination
CTB	Components Technology Board
EEE	Electrical, Electronic and Electro-mechanical
ESCC	European Space Components Coordination
ESCIES	European Space Components Information Exchange System
Executive	ESCC Executive
PSWG	Policy and Standards Working Group
SCSB	Space Components Steering Board
Secretariat	The ESCC Executive Secretariat

NOTES:

The Secretariat referring to the secretariat of the ESCC Executive is distinct and separate from the ESCC Secretariat. The former supports the Executive task, the latter the Harmonisation task. This distinction is amplified in ESCC 00000 and ESCC 10200

4 RELATED DOCUMENTS

4.1 APPLICABLE DOCUMENTS

The following documents are applicable to the extent specified herein:

ESCC 00000	Charter of the European Space Components Coordination
ESCC 10200	Organisation and Basic Rules of the Executive
ESCC 12002	Procedure for ESCC Document and Specification Management
ESCC 12003	Procedure for ESCC Document and Specification Administration
ESCC 20800	New ESCC Specifications and Specification Change Requests

4.2 REFERENCE DOCUMENTS

ESCC 11001	Procedure for Configuration Management
REP001	List of ESCC Documents and Specifications under Configuration Control
REP002	List of Withdrawn ESCC Documents and Specifications

5 RESPONSIBILITIES

Each ESCC Organisational Body shall generate and use internal working procedures sufficient to implement the procedural aspects of this ESCC Document for which they are responsible.

5.1 SCSB

The SCSB shall:

- Maintain overall responsibility for the management of the ESCC documentation system.
- Expand or modify the documentation system architecture as and when required to support the documents and specifications resulting from ESCC activities.
- Approve and authorise ESCC documents and specifications as required by ESCC 12002.

5.2 PSWG

The PSWG shall:

- Define requirements, rules and procedures for the operation, maintenance and expansion of the ESCC Specification System.
- Advise the SCSB when the documentation system architecture requires modification or expansion.
- Liaise with the Executive over the implementation of the documentation system architecture and in the preparation and publishing of the documentation.
- Liaise with the ESCC Secretariat over the handling of working documents, draft papers and reports.

5.3 EXECUTIVE

The Executive shall operate the documentation system in accordance with ESCC 12003 so that, through the Secretariat, it:

- Controls and maintains records of documents and specifications in preparation or under change.
- Uniquely identifies documents and specifications in accordance with the architecture and rules defined in this procedure.
- Places documents and specifications under configuration control prior to publication.
- Provides an editing and document content management system appropriate to the long term support of ESCC documents and specifications.
- Ensures that the style of ESCC documents and specifications is consistently based on a set of rules.
- Provides an electronic distribution system for the provision of all available ESCC documents and specifications to users.

5.4 ESCC SECRETARIAT

The ESCC Secretariat shall:

- Uniquely identify working documents, draft papers and reports produced by the ESCC Organisational Bodies which it supports.
- Control and maintain records of the working documents, draft papers and reports produced by the ESCC Organisational Bodies which it supports.
- Liaise with the Secretariat on the coding, publication and records of any ESCC standing report emanating from the Harmonisation task.

5.5 DOCUMENTATION SYSTEM USERS

System users shall:

- Support the expansion of the Specification system and contribute to its accuracy and relevance by submitting new specifications and change proposals in accordance with ESCC Basic Specification No. 20800.

6 ESCC DOCUMENTATION ARCHITECTURE

6.1 DESCRIPTION

The ESCC is supported by a system of formal documents and specifications which comprise two distinct types:

- Policy and administrative documentation describes the policy, organisation, responsibilities, tasks, and rules of procedure and is produced by the ESCC Organisational Bodies. These documents generally take the form of procedures tracking a particular ESCC process and normally cross organisational boundaries.
- ESCC Specifications provide a description of components and the processes for their qualification. ESCC specifications are written in a form suitable for reference in a purchase contract or similar document. The normative elements comprise, inter alia, performance requirements, test methods, inspection requirements, conditions of test and terminology.

These documents and specifications are incorporated into a single documentation architecture which is made up of the following levels:

- **Level 0: Policy**
These are the primary ESCC policy documents on which the ESCC is established, constituted and organised. Level 0 documents lay down the foundation of the ESCC, its objectives and policy, organisation, management and the terms of reference of its constituent organisations. They also provide for the identification of founding members organisations, memorandums of understanding, resources and signatories to the terms and provisions of the system.
- **Level 1: Organisation, Support and Implementation**
These are the ESCC organisational, rules, policy and procedural documents. Level 1 documents expand on the level 0 subject matter in respect of its organisational structure, processes and the implementation of the requirements of the system.
- **Level 2: Basic Specifications**
ESCC Basic Specifications are applicable to EEE components or groups of components, and provide common processes and rules.
- **Level 3: Generic Specifications**
ESCC Generic Specifications provide requirements and test methods applicable to a family or sub family of EEE components.
- **Level 4: Detail Specifications**
ESCC Detail Specifications provide a description of specific components or ranges of structurally similar components and give performance requirements, conditions of test, and approval, quality conformance and inspection requirements. Level 4 specifications are primary procurement specifications for ESCC qualified components. They are intended for use in conjunction with the corresponding Generic Specification and referenced Basic Specifications.

6.2 DOCUMENTATION ARCHITECTURE – OVERVIEW

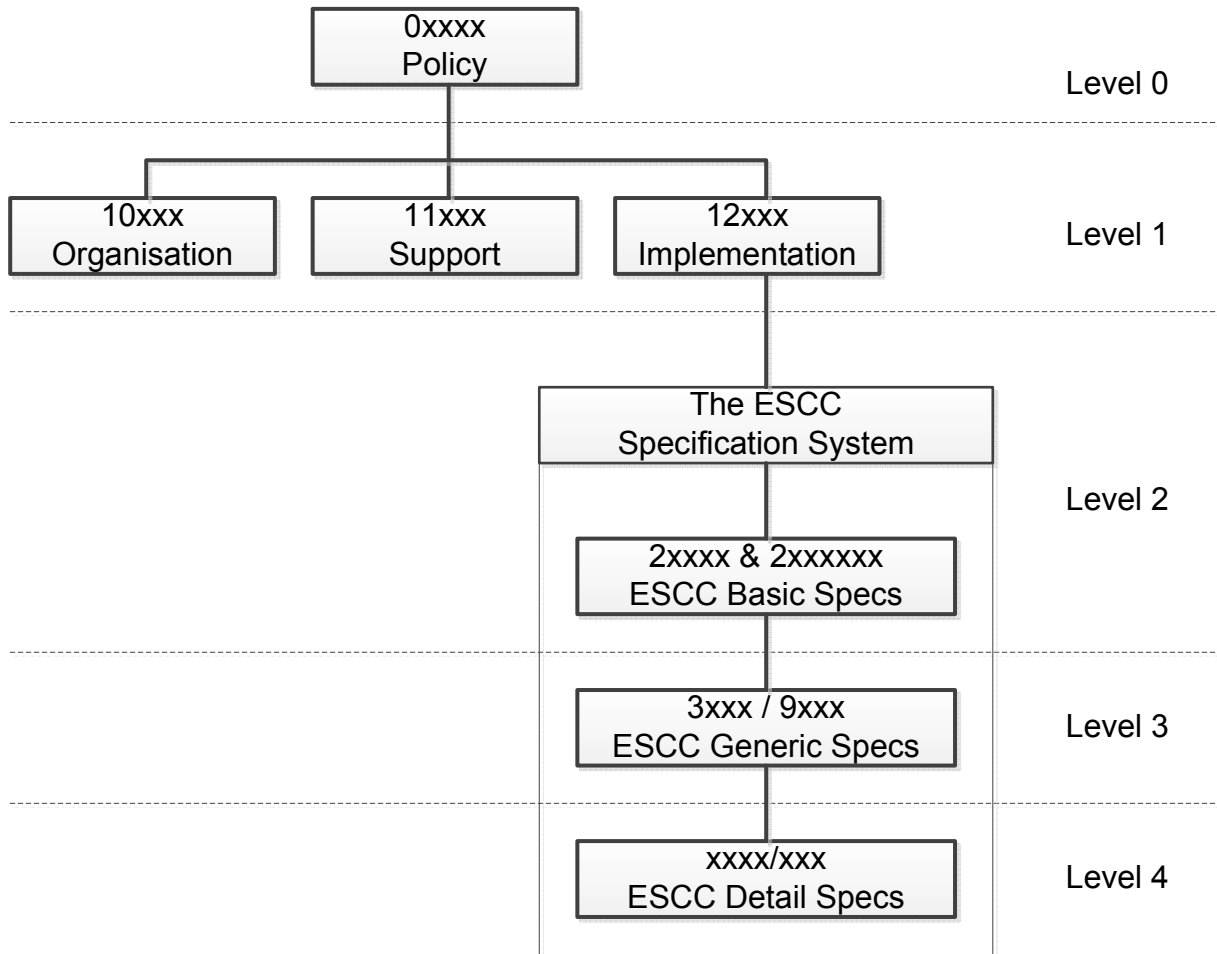

6.3 LEVEL 0 DOCUMENTS

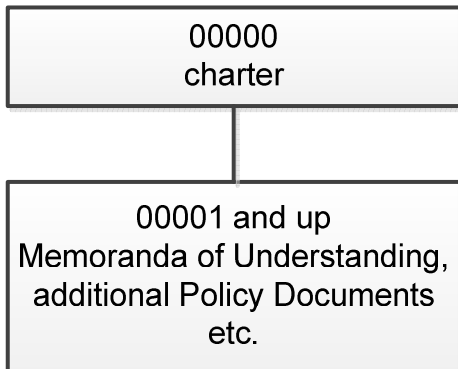

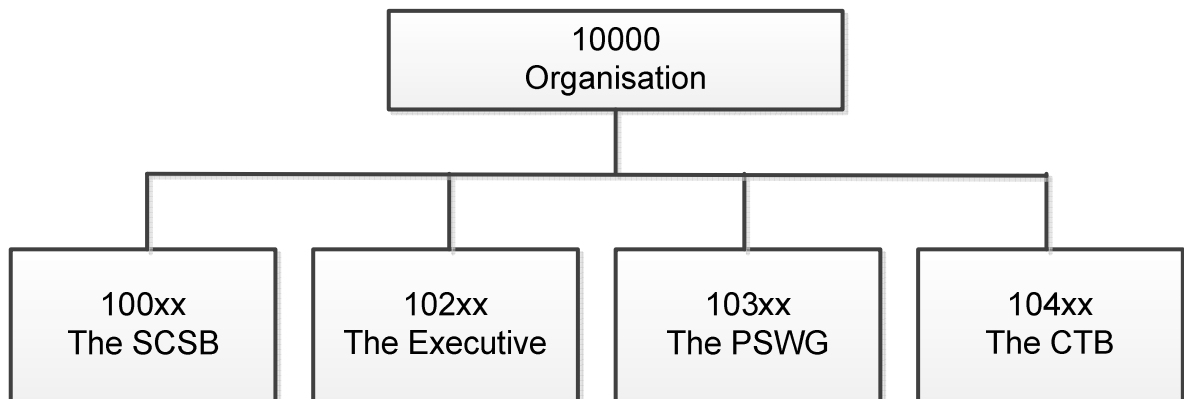
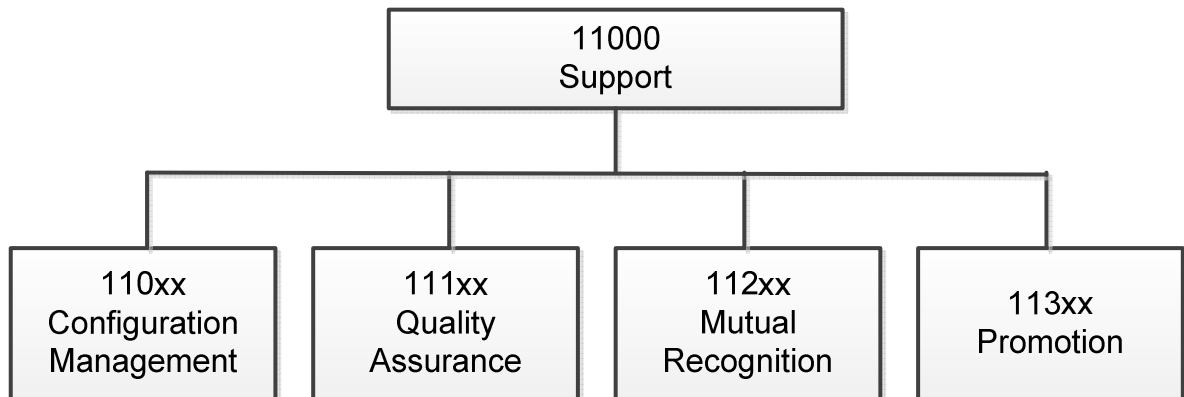
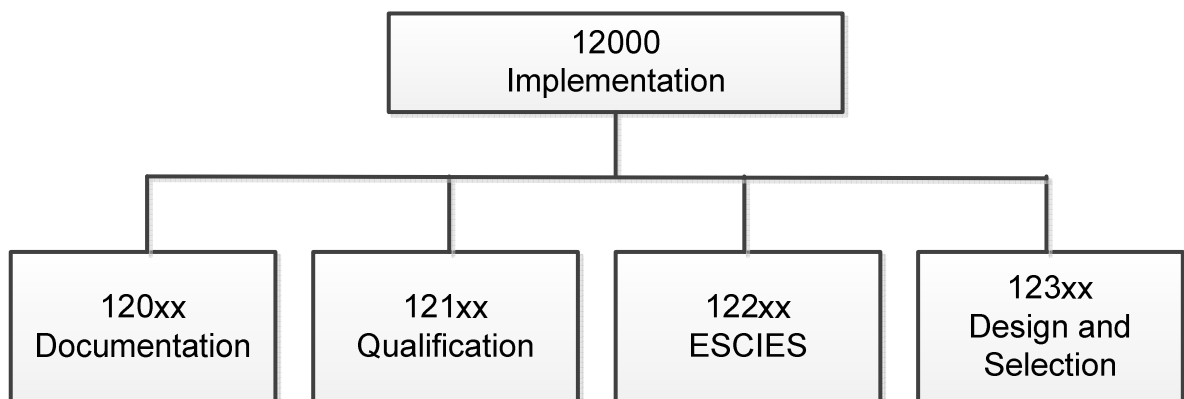
6.4 LEVEL 1 DOCUMENTS – ORGANISATION6.5 LEVEL 1 DOCUMENTS - SUPPORT6.6 LEVEL 1 DOCUMENTS - IMPLEMENTATION

6.7 LEVELS 2, 3 AND 4 DOCUMENTS – SPECIFICATIONS

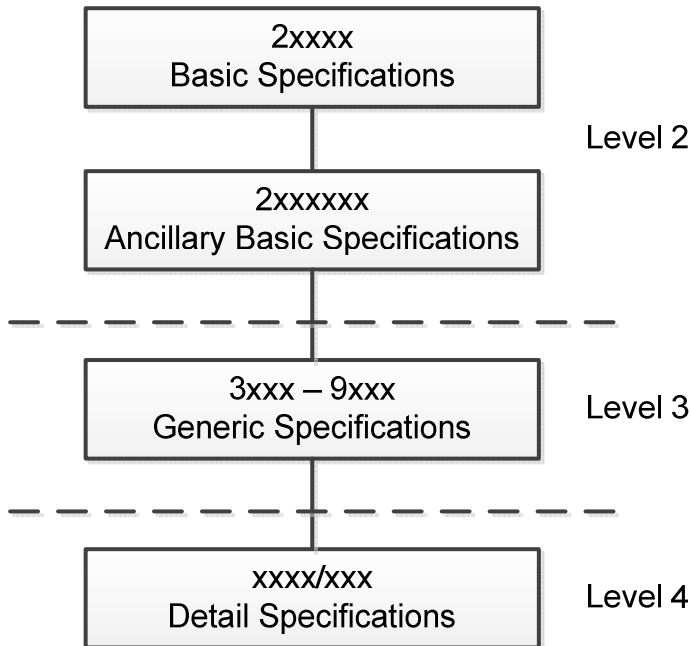

7 CODING OF ISSUED DOCUMENTS AND SPECIFICATIONS

The Secretariat shall assign document and specification codes in accordance with the Documentation Architecture and the following rules. The procedural aspects shall be as defined in ESCC 12003. In so far as the codes applied have any meaning beyond that directly specified herein the Secretariat shall publish the assigned meanings on the ESCC or ESCIES web site.

7.1 GENERAL

ESCC Documents are classified into two levels:

- Level 0 - Policy.
- Level 1 - Organisation, Support and Implementation.

All Documents issued in these categories are identified by a unique 5 digit number. The range of allowed numbers is 00000 to 19999.

ESCC Specifications are classified into three levels:

- Basic Specifications
Basic Specifications are either self-standing and cover a specific topic or are Parent Basic Specifications which are expanded upon by Ancillary Basic Specifications.
Ancillary Basic Specifications include additional requirements related to a specific family or sub-family of components.
All Basic Specifications are identified by a unique 5 digit or 7 digit number. The ranges of allowed numbers are 20000 to 29999 and 2003000 to 2999999
Basic specifications may include actual requirements (normative) or sets of guidelines (non-normative). In the last case, the title of the document shall always identify it as "GUIDELINES"

- **Generic Specifications**
All Generic Specifications are identified by a unique 4 digit number. The ranges of allowed numbers are 3000 to 9999.
- **Detail Specifications**
All Detail Specifications are identified by a unique 7 digit number separated into a group of 4 digits followed by a group of 3 digits with a / as a separator. The ranges of allowed numbers are 3000/001 to 9999/999.

7.2 LEVEL 0 DOCUMENTS

Of the 5 digits, the first denotes the Level of the Document and thus is always a 0.

The following 4 digits denote the serial number of Documents, in the order in which they are written.

7.3 LEVEL 1 DOCUMENTS

The first digit denotes the Level of the Document and thus is always a 1.

The second digit indicates the type of subject matter dealt with by the Document and is:

- 0 for Organisation
- 1 for Support
- 2 for Implementation

The third digit indicates the sub theme under either Organisation, Support or Implementation.

The last 2 digits denote the serial number of Documents in the order in which they are written.

7.4 LEVEL 2 SPECIFICATIONS (BASIC)

- **5 Digit Codes (Self standing and parent specifications)**
The first digit denotes the Level of the Specification and thus is always a 2.
The second and third digits denote the subject matter.
The last 2 digits denote the serial number of specifications in the order in which they are written. 00 is reserved and used for the general requirements for a particular subject.
- **7 Digit Codes (Ancillary specifications)**
The first digit denotes the Level of the Document and thus is always a 2.
The second and third digits indicate the subject matter directly corresponding to the second and third digits of the 5 digit code.
The last four digits correspond to the Generic code for the family or sub-family of components to which the ancillary specification is applicable.

Examples:

- 21500 is the Basic Specification for calibration system requirements and is self-standing. There are no ancillary specifications.
- 20400 is the Basic Specification for general requirements for internal visual inspection and is a Parent Specification.
- 2049000 is the Basic Specification for internal visual inspection of integrated circuits and is an Ancillary Specification.

7.5 LEVEL 3 SPECIFICATIONS (GENERIC)

The first and second digits denote the family of components.

The third and fourth digits indicate that the Generic covers a specific sub-family.

7.6 LEVEL 4 SPECIFICATIONS (DETAIL)

The first digit denotes the family of components and corresponds to the first digit of the associated Generic Specification.

The second through fourth digits are arranged in two groups of two digits. These are used to code further information common to a group of components. For example the first two digits may code a sub-family and the last two digits a functional group.

After the "/" delimiter the fifth through seventh digits denote the serial number of Specifications in the order in which they are written.

8 CODING OF DRAFT DOCUMENTS AND SPECIFICATIONS

The Secretariat shall assign a reference number for any draft document or specification under preparation in accordance with the requirements of ESCC 12003.

The reference number shall appear on each page of the draft and shall be of the form CAxxxxx. CA represents Code Application and xxxxx are five digits incrementing from 00001 to provide a unique reference number.

9 ISSUE STATUS

9.1 GENERAL

The issue status of an ESCC Document or Specification is given on every page. The issue status is for the document or specification as a whole and not for individual pages.

9.2 ISSUED DOCUMENTS AND SPECIFICATIONS

The issue is given by the word ISSUE followed by a numeric commencing with 1, i.e. ISSUE 1. The issue is increased sequentially thereafter for each authorised issue ensuing from an approved change to the document or specification.

9.3 DRAFT DOCUMENTS AND SPECIFICATIONS

There shall be no possibility to confuse draft documents and specifications with issued ones.

Each version of a draft shall be identified on each page by the word DRAFT and a letter commencing with A, i.e. DRAFT A. For each subsequent draft the next letter shall be used, e.g. DRAFT B, DRAFT C etc. In addition the date of completion of the particular draft shall be identified on the front sheet.

When a major rewrite of an issued document or specification is effected by means of a covering DCR and a changed copy of the existing issue then the issue number shall be given an increment and a draft letter added on every page. For example, a changed ISSUE 1 shall be identified as ISSUE 2 Draft A. Any subsequent revision of the draft shall use the next draft letter e.g. DRAFT B, DRAFT C etc.

10 REPORTS, WORKING PAPERS AND ADMINISTRATIVE DOCUMENTATION

10.1 DOCUMENTATION TYPES

ESCC Organisational Bodies produce a wide range of documents and papers. (These may be either not part of the formal documentation system or, if intended for eventual publication, are in the early course of preparation.) These include:

- Reports
These fulfil a key ESCC output requirement and are produced periodically to report on project and task progress.
- Working Papers
These are usually technical, correspondence and administrative papers, circulating within or between the organisational bodies and working groups.
- Agendas and Minutes
These comprise meeting calling notices and the official records of meetings held by ESCC Organisational Bodies and working groups.
- ESCC Executive Public Notices (EPPN)

10.2 REPORTS

In order to promote consistency and ease of understanding, reports generated by the ESCC organisational bodies shall conform as far as is practicable to the requirements of ESCC publication standards as set by the Executive. Report content shall as a minimum include the following:

- An authorisation and indication of origin.
- A reference number.
- A copy number (where appropriate).
- A distribution list (where appropriate).
- Issue identification which as a minimum shall be the date of issue.
- Record of changes (where appropriate).
- Executive summary (where appropriate).
- List of contents.
- Abbreviations (where appropriate)
- Acknowledgements (where appropriate)

ESCC Reports generally are either unique reports on a particular subject or are standing reports routinely updated. Reports are generated from both the Harmonisation and Executive tasks.

The appropriate secretariat (ESCC or Executive) shall be included in the distribution of all published reports, and will retain a master copy. The appropriate secretariat shall maintain a list of all additional requests for copies of reports beyond those included in the initial distribution.

The appropriate secretariat shall operate internal procedures for the issuing of reports which provide for configuration management. This shall ensure that there is a record of authorisation to issue each report.

- **Unique Reports**
ESCC unique reports shall be given a reference number by the issuer, either the appropriate secretariat or the ESCC body concerned, sufficient to act as an identifier for the report.
- **Standing Reports**
ESCC standing reports, irrespective of whether they reflect a Harmonisation task or an Executive task, shall be issued through the Secretariat. They are identified by REPxxx where xxx are three digits incrementing from 001 to provide a unique reference number.

Examples of Standing Reports are:

- REP001 (list of published specifications),
- REP002 (list of discontinued specifications),
- REP005 (ESCC Qualified Parts List)
- REP006 (ESCC Qualified Manufacturers List)
- REP007 (ESCC list of Process Capability Approval certificates)

10.3 WORKING PAPERS

The ESCC Secretariat shall circulate working papers as directed by the SCSB and PSWG or the relevant working group.

The ESCC Secretariat shall give working papers an internal reference number sufficient to act as an identifier.

10.4 AGENDAS AND MINUTES

The ESCC Secretariat shall circulate agendas and minutes as directed by the SCSB and PSWG or the relevant working group.

The ESCC Secretariat shall give agendas and minutes an internal reference number sufficient to act as an identifier.

11 AVAILABILITY OF ESCC DOCUMENTS AND SPECIFICATIONS

ESCC Documents and Specifications, when duly authorised, shall be published electronically by the Executive through the Secretariat. This is described in ESCC 12002 and ESCC 12003.

A full list of ESCC documents and specifications under configuration control and those which have been withdrawn are provided in ESCC REP001 and ESCC REP002 respectively.

12 RESPONSIBILITY FOR THE PREPARATION OF ESCC DOCUMENTS AND SPECIFICATIONS

The procedures for the preparation of Level 0 and 1 documents and Level 2, 3 and 4 specifications are described in ESCC 12002.

The primary responsibility for the preparation of ESCC documents and specifications are summarised below:

- SCSB: Level 0
- PSWG: Level 1, 2, 3 and *4
- Executive: Level *4

* The preparation of the first Detail Specification for a given Generic Specification is the responsibility of the PSWG. The Executive is responsible for subsequent Detail Specifications.

13 CONFIGURATION CONTROL OF ESCC DOCUMENTS AND SPECIFICATIONS

ESCC level 0, 1, 2, 3, and 4 Documents and Specifications are controlled documents and changes to them shall be processed in accordance with ESCC Basic Specification No. 20800.

The configuration control procedures are described in ESCC 12002.

14 RECORDS AND REPORTING

The records to be kept and the reports required for the operation of the ESCC documentation system are provided in ESCC 12002 and ESCC 12003.