



Page 1 of 16

TRANSISTORS, HIGH POWER, NPN

BASED ON TYPE BUX77

ESCC Detail Specification No. 5203/016

Issue 4	October 2016
---------	--------------



Document Custodian: European Space Agency – see <https://escies.org>

LEGAL DISCLAIMER AND COPYRIGHT

European Space Agency, Copyright © 2016. All rights reserved.

The European Space Agency disclaims any liability or responsibility, to any person or entity, with respect to any loss or damage caused, or alleged to be caused, directly or indirectly by the use and application of this ESCC publication.

This publication, without the prior permission of the European Space Agency and provided that it is not used for a commercial purpose, may be:

- copied in whole, in any medium, without alteration or modification.
- copied in part, in any medium, provided that the ESCC document identification, comprising the ESCC symbol, document number and document issue, is removed.

DOCUMENTATION CHANGE NOTICE

(Refer to <https://escies.org> for ESCC DCR content)

DCR No.	CHANGE DESCRIPTION
1002	Specification upissued to incorporate editorial changes per DCR.

TABLE OF CONTENTS

1	GENERAL	5
1.1	SCOPE	5
1.2	APPLICABLE DOCUMENTS	5
1.3	TERMS, DEFINITIONS, ABBREVIATIONS, SYMBOLS AND UNITS	5
1.4	THE ESCC COMPONENT NUMBER AND COMPONENT TYPE VARIANTS	5
1.4.1	The ESCC Component Number	5
1.4.2	Component Type Variants	5
1.5	MAXIMUM RATINGS	6
1.6	HANDLING PRECAUTIONS	7
1.7	PHYSICAL DIMENSIONS AND TERMINAL IDENTIFICATION	7
1.7.1	Metal Flange Mount Package (TO-66) - 2 lead	8
1.7.2	Metal Flange Mount Package (TO-257) - 3 lead	9
1.7.3	Notes to Physical Dimensions and Terminal Identification	10
1.8	FUNCTIONAL DIAGRAM	10
1.9	MATERIALS AND FINISHES	10
2	REQUIREMENTS	10
2.1	GENERAL	10
2.1.1	Deviations from the Generic Specification	11
2.2	MARKING	11
2.3	TERMINAL STRENGTH	11
2.4	VERIFICATION OF SAFE OPERATING AREA	11
2.5	ELECTRICAL MEASUREMENTS AT ROOM, HIGH AND LOW TEMPERATURES	11
2.5.1	Room Temperature Electrical Measurements	11
2.5.2	High and Low Temperatures Electrical Measurements	13
2.6	PARAMETER DRIFT VALUES	14
2.7	INTERMEDIATE AND END-POINT ELECTRICAL MEASUREMENTS	14
2.8	POWER BURN-IN CONDITIONS	14
2.9	OPERATING LIFE CONDITIONS	15
	APPENDIX 'A'	16

1 GENERAL

1.1 SCOPE

This specification details the ratings, physical and electrical characteristics and test and inspection data for the component type variants and/or the range of components specified below. It supplements the requirements of, and shall be read in conjunction with, the ESCC Generic Specification listed under Applicable Documents.

1.2 APPLICABLE DOCUMENTS

The following documents form part of this specification and shall be read in conjunction with it:

- (a) ESCC Generic Specification No. [5000](#)
- (b) MIL-STD-750, Test Methods and Procedures for Semiconductor Devices

1.3 TERMS, DEFINITIONS, ABBREVIATIONS, SYMBOLS AND UNITS

For the purpose of this specification, the terms, definitions, abbreviations, symbols and units specified in ESCC Basic Specification No. [21300](#) shall apply.

1.4 THE ESCC COMPONENT NUMBER AND COMPONENT TYPE VARIANTS

1.4.1 The ESCC Component Number

The ESCC Component Number shall be constituted as follows:

Example: 520301603

- Detail Specification Reference: 5203016
- Component Type Variant Number: 03 (as required)

1.4.2 Component Type Variants

The component type variants applicable to this specification are as follows:

Variant Number	Based on Type	Case	Lead/Terminal Material and Finish	Weight max g
03	BUX77	TO-66	F9	6.4
04	BUX77	TO-66	F2	6.4
05	BUX77	TO-66	F3 or F4	6.4
06	BUX77	TO-257	H2	5
07	BUX77	TO-257	H4	5

The lead/terminal material and finish shall be in accordance with the requirements of ESCC Basic Specification No. [23500](#).

1.5 MAXIMUM RATINGS

The maximum ratings shall not be exceeded at any time during use or storage.

Maximum ratings shall only be exceeded during testing to the extent specified in this specification and when stipulated in Test Methods and Procedures of the ESCC Generic Specification.

Characteristics	Symbols	Maximum Ratings	Unit	Remarks
Collector-Base Voltage	V_{CBO}	100	V	Over T_{op}
Collector-Emitter Voltage	V_{CEO}	80	V	Over T_{op} Note 3
Emitter-Base Voltage	V_{EBO}	6	V	Over T_{op}
Collector Current	I_C	5	A	Continuous Note 3
Base Current	I_B	800	mA	Continuous
Power Dissipation	P_{tot}		W	At $T_{case} \leq +25^{\circ}C$
For TO-66		40		
For TO-257		35		
Thermal Resistance Junction-to-Case	$R_{th(j-c)}$		$^{\circ}C/W$	
For TO-66		4.4		
For TO-257		5		
Operating Temperature Range	T_{op}	-65 to +200	$^{\circ}C$	Note 1
Storage Temperature Range	T_{stg}	-65 to +200	$^{\circ}C$	Note 1
Soldering Temperature	T_{sol}	+260	$^{\circ}C$	Note 2

NOTES:

- For Variants with tin-lead plating or hot solder dip lead finish all testing, and any handling, performed at $T_{amb} > +125^{\circ}C$ shall be carried out in a 100% inert atmosphere.
- Duration 10 seconds maximum at a distance of not less than 1.5mm from the device body and the same lead shall not be resoldered until 3 minutes have elapsed.
- Safe Operating Area applies as follows:

Maximum Safe Operating Area Graph

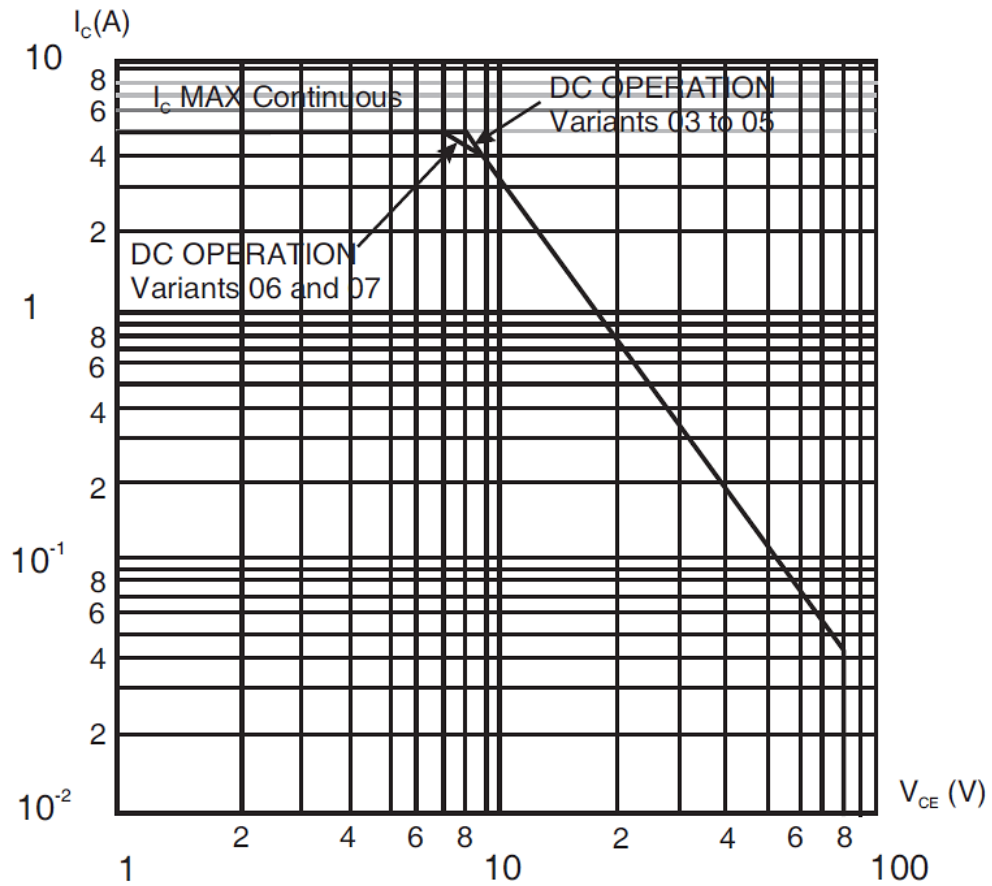

1.6 HANDLING PRECAUTIONS

The TO-257 package contains Beryllium Oxide (BeO) and therefore it must not be ground, machined, sandblasted or subjected to any mechanical operation which will produce dust. The case must not be subjected to any chemical process (e.g. etching) which will produce fumes.

1.7 PHYSICAL DIMENSIONS AND TERMINAL IDENTIFICATION

Consolidated Notes are given following the case drawings and dimensions.

1.7.1 Metal Flange Mount Package (TO-66) - 2 lead

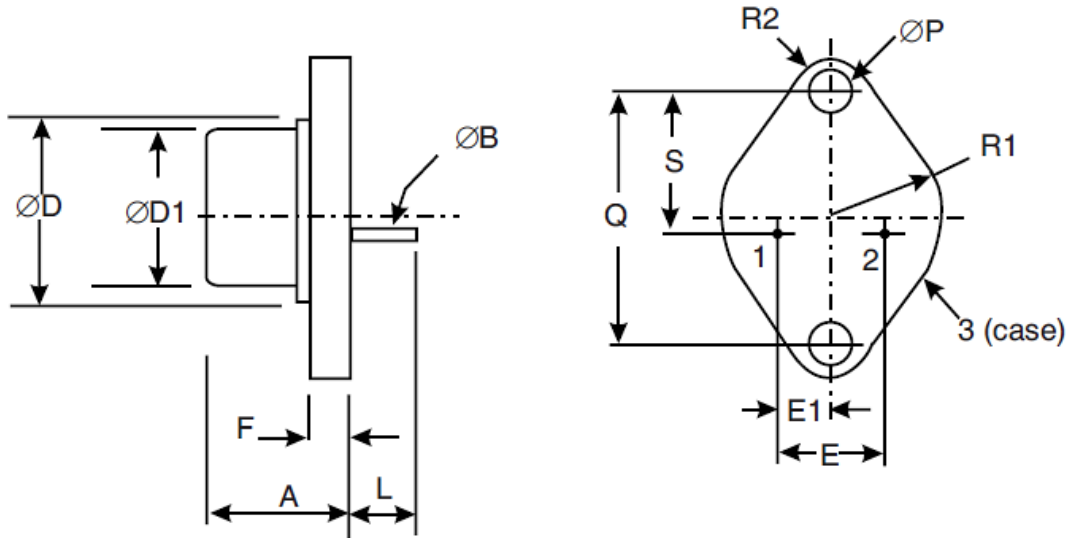

Symbols	Dimensions mm		Notes
	Min	Max	
A	6.35	8.64	
$\varnothing B$	0.71	0.86	2
$\varnothing D$	-	15.74	
$\varnothing D1$	11.94	12.7	
E	4.83	5.34	
E1	2.36	2.72	
F	1.27	1.91	
L	9.14	-	
$\varnothing P$	3.61	3.86	3
Q	24.33	24.43	
R1	-	8.89	
R2	2.92	3.68	
S	14.48	14.99	

1.7.3 Notes to Physical Dimensions and Terminal Identification

1. Terminal identification is specified by the component's geometry where Lead 1 = emitter, Lead 2 = base and Lead 3 (TO-257) or Case (TO-66) = collector.
2. Applies to all leads.
3. Applies to both mounting holes.
4. Radius of body corner, 4 places.

1.8 FUNCTIONAL DIAGRAM

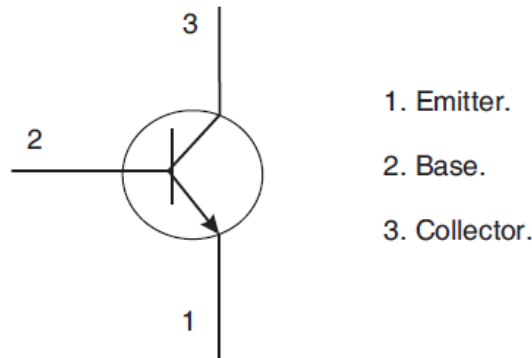

NOTES:

1. For TO-66, the collector is internally connected to the case.
2. For TO-257, the case is not connected to any lead.

1.9 MATERIALS AND FINISHES

Materials and finishes shall be as follows:

- (a) Case
For the metal flange mount (TO-66) package the case shall be hermetically sealed and have a metal body with hard glass seals.
For the metal flange mount (TO-257) package the case shall be hermetically sealed and have a metal body. The leads pass through ceramic eyelets brazed into the frame and the lid shall be welded.
- (b) Leads/Terminals
As specified in Component Type Variants.

2 REQUIREMENTS

2.1 GENERAL

The complete requirements for procurement of the components specified herein are as stated in this specification and the ESCC Generic Specification. Permitted deviations from the Generic Specification, applicable to this specification only, are listed below.

Permitted deviations from the Generic Specification and this Detail Specification, formally agreed with specific Manufacturers on the basis that the alternative requirements are equivalent to the ESCC requirement and do not affect the component's reliability, are listed in the appendices attached to this specification.

2.1.1 Deviations from the Generic Specification

- (a) Deviation from Screening Tests - Chart F3
High Temperature Reverse Bias Burn-in and the subsequent Final Measurements for HTRB shall be omitted.

2.2 MARKING

The marking shall be in accordance with the requirements of ESCC Basic Specification No. 21700 and as follows.

The information to be marked on the component shall be:

- (a) The ESCC qualified components symbol (for ESCC qualified components only).
- (b) The ESCC Component Number.
- (c) Traceability information.
- (d) Warning sign for Beryllium Oxide (TO-257 only).

2.3 TERMINAL STRENGTH

The test conditions for terminal strength, tested as specified in the ESCC Generic Specification, shall be as follows:

- Test Condition A, tension, with an applied force of 10N for a duration of 10s.

2.4 VERIFICATION OF SAFE OPERATING AREA

The Safe Operating Area shall be verified as specified in the ESCC Generic Specification and Maximum Ratings herein. The test conditions shall be:

- Test Method = [MIL-STD-750, Method 3051](#), Continuous DC
- $T_{case} = +25^{\circ}C$
- $V_{CE} = 12V$
- $I_C = 2A$
- Operating Time $\leq 100ms$

2.5 ELECTRICAL MEASUREMENTS AT ROOM, HIGH AND LOW TEMPERATURES

Electrical measurements shall be performed at room, high and low temperatures.

2.5.1 Room Temperature Electrical Measurements

The measurements shall be performed at $T_{amb} = +22 \pm 3^{\circ}C$.

Characteristics	Symbols	MIL-STD-750 Test Method	Test Conditions	Limits		Units
				Min	Max	
Collector-Emitter Breakdown Voltage	$V_{(BR)CEO}$	3011	$I_C = 50mA$ Bias condition D Note 1	80	-	V
	$V_{(BR)CES}$	3011	$I_C = 2mA$ Bias condition C	100	-	V
Emitter-Base Breakdown Voltage	$V_{(BR)EBO}$	3026	$I_E = 1mA$ Bias condition D	6	-	V

Characteristics	Symbols	MIL-STD-750 Test Method	Test Conditions	Limits		Units
				Min	Max	
Collector-Emitter Cut-off Current	I_{CEO}	3041	$V_{CE} = 60V$ Bias condition D	-	10	μA
Collector-Base Cut-off Current	I_{CBO}	3036	$V_{CB} = 80V$ Bias condition D	-	500	nA
Emitter-Base Cut-off Current	I_{EBO}	3061	$V_{EB} = 4V$ Bias condition D	-	500	nA
Forward-Current Transfer Ratio	h_{FE1}	3076	$V_{CE} = 5V, I_C = 500mA$ Note 1	70	-	-
	h_{FE2}	3076	$V_{CE} = 5V, I_C = 2A$ Note 1	50	200	-
	h_{FE3}	3076	$V_{CE} = 5V, I_C = 5A$ Note 1	30	-	-
Collector-Emitter Saturation Voltage	$V_{CE(sat)}$	3071	$I_C = 5A, I_B = 500mA$ Note 1	-	1	V
Base-Emitter Saturation Voltage	$V_{BE(sat)}$	3066	$I_C = 5A, I_B = 500mA$ Test condition A Note 1	-	1.3	V
High Frequency Small Signal Current Gain	h_{fe}	3306	$V_{CE} = 5V, I_C = 500mA$ $f = 20MHz$ Note 2	2.5	-	-
Turn-on Time	t_{on}	-	$I_C = 5A$ $I_{B1} = 500mA$ $I_{B2} = -500mA$ $V_{CC} = 40V, V_{BB} = -4V$ $V_{IN} \approx 51V$ Notes 2, 3	-	300	ns
Turn-off Time	t_{off}	-	$I_C = 5A,$ $I_{B1} = 500mA$ $I_{B2} = -500mA$ $V_{CC} = 40V, V_{BB} = -4V$ $V_{IN} \approx 51V$ Notes 2, 3	-	700	ns

NOTES:

1. Pulsed measurement: Pulse Width $\leq 300\mu s$, Duty Cycle $\leq 2\%$.
2. For AC characteristics read and record measurements shall be performed on a sample of 32 components with 0 failures allowed. Alternatively a 100% inspection may be performed.
3. t_{on} and t_{off} shall be measured using the following test circuit. The input waveform shall be supplied by a pulse generator with the following characteristics: $t_r \leq 20ns$, Pulse Width = $10\mu s$, Duty Cycle = 1%. The sampling oscilloscope for CH.A and CH.B shall have the characteristics $Z_{IN} \geq 100k\Omega$, $C_{IN} \geq 12pF$ and $t_f \leq 5ns$. Adjustment of V_{IN} shall be made with a suitable current probe to achieve the specified I_{B1} and I_{B2} test conditions, where I_{B1} is the on-state base current and I_{B2} is the post off-state base current.

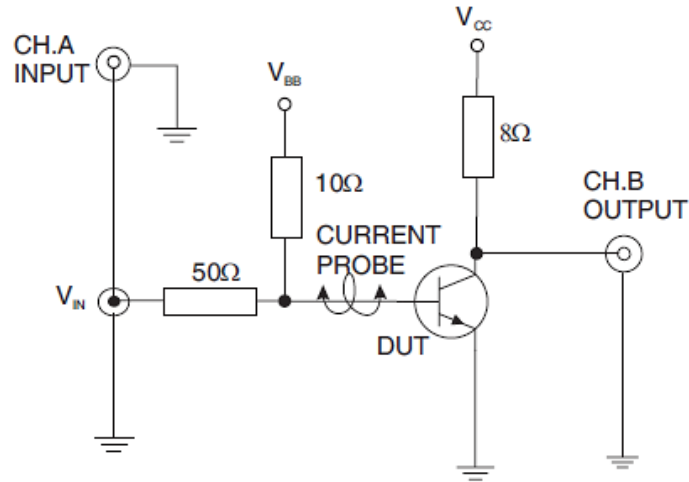

VOLTAGE WAVEFORMS

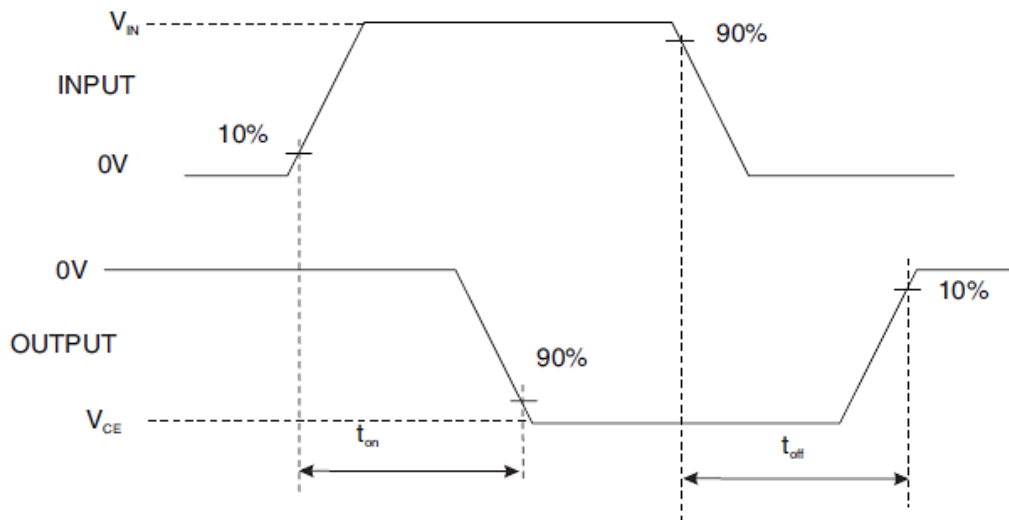

2.5.2 High and Low Temperatures Electrical Measurements

Characteristics	Symbols	MIL-STD-750 Test Method	Test Conditions Note 1	Limits		Units
				Min	Max	
Collector-Base Cut-off Current	I_{CBO}	3036	$T_{amb} = +150 (+0 -5)^{\circ}C$ $V_{CB} = 80V$ Bias condition D	-	150	μA
Forward-Current Transfer Ratio 4	h_{FE4}	3076	$T_{amb} = -55 (+5 -0)^{\circ}C$ $V_{CE} = 5V, I_C = 1A$ Note 2	25	-	-

NOTES:

1. Read and record measurements shall be performed on a sample of 5 components with 0 failures allowed. Alternatively a 100% inspection may be performed.
2. Pulsed measurement: Pulse Width $\leq 300\mu s$, Duty Cycle $\leq 2\%$.

2.6 PARAMETER DRIFT VALUES

Unless otherwise specified, the measurements shall be performed at $T_{amb} = +22 \pm 3^{\circ}\text{C}$.

The test methods and test conditions shall be as per the corresponding test defined in Room Temperature Electrical Measurements.

The drift values (Δ) shall not be exceeded for each characteristic specified. The corresponding absolute limit values for each characteristic shall not be exceeded.

Characteristics	Symbols	Limits			Units
		Drift Value Δ	Absolute		
			Min	Max	
Emitter-Base Cut-off Current	I_{EBO}	± 100	-	500	nA
Forward-Current Transfer Ratio 2	h_{FE2}	$\pm 25\%$	50	200	-
Collector-Emitter Saturation Voltage	$V_{CE(sat)}$	± 100	-	1000	mV

2.7 INTERMEDIATE AND END-POINT ELECTRICAL MEASUREMENTS

Unless otherwise specified, the measurements shall be performed at $T_{amb} = +22 \pm 3^{\circ}\text{C}$.

The test methods and test conditions shall be as per the corresponding test defined in Room Temperature Electrical Measurements.

The limit values for each characteristic shall not be exceeded.

Characteristics	Symbols	Limits		Units
		Min	Max	
Collector-Emitter Cut-off Current	I_{CEO}	-	10	μA
Forward-Current Transfer Ratio 2	h_{FE2}	50	200	-
Collector-Emitter Saturation Voltage	$V_{CE(sat)}$	-	1	V

2.8 POWER BURN-IN CONDITIONS

Characteristics	Symbols	Conditions	Units
Case Temperature	T_{case}	+100 (+0 -5) (1)	$^{\circ}\text{C}$
Power Dissipation	P_{tot}	As per Maximum Ratings. Derate P_{tot} at the specified T_{case} using the specified $R_{th(j-c)}$.	W
Collector-Emitter Voltage	V_{CE}	10	V

NOTES:

1. No heat sink nor forced air directly on the device shall be permitted.



2.9 OPERATING LIFE CONDITIONS

The conditions shall be as specified for Power Burn-in.

APPENDIX 'A'
AGREED DEVIATIONS FOR STMICROELECTRONICS (F)

ITEMS AFFECTED	DESCRIPTION OF DEVIATIONS
Deviations from Room Temperature Electrical Measurements	All AC characteristics (Room Temperature Electrical Measurement Note 2) may be considered guaranteed but not tested if successful pilot lot testing has been performed on the wafer lot which includes AC characteristic measurements per the Detail Specification. A summary of the pilot lot testing shall be provided if required by the Purchase Order.
Deviations from High and Low Temperatures Electrical Measurements	All characteristics specified may be considered guaranteed but not tested if successful pilot lot testing has been performed on the wafer lot which includes characteristic measurements at high and low temperatures per the Detail Specification. A summary of the pilot lot testing shall be provided if required by the Purchase Order.
Deviations from Screening Tests - Chart F3	Solderability is not applicable unless specifically stipulated in the Purchase Order.