



**CAPACITORS, FIXED, CERAMIC DIELECTRIC,
TYPE II, HIGH CAPACITANCE, 50V TO 500V**

BASED ON TYPES BR, CV AND CH

ESCC Detail Specification No. 3001/030

Issue 7 Draft C	September 2016
-----------------	----------------



LEGAL DISCLAIMER AND COPYRIGHT

European Space Agency, Copyright © 2016. All rights reserved.

The European Space Agency disclaims any liability or responsibility, to any person or entity, with respect to any loss or damage caused, or alleged to be caused, directly or indirectly by the use and application of this ESCC publication.

This publication, without the prior permission of the European Space Agency and provided that it is not used for a commercial purpose, may be:

- copied in whole, in any medium, without alteration or modification.
- copied in part, in any medium, provided that the ESCC document identification, comprising the ESCC symbol, document number and document issue, is removed.

DOCUMENTATION CHANGE NOTICE

(Refer to <https://escies.org> for ESCC DCR content)

DCR No.	CHANGE DESCRIPTION
725	Specification updated to incorporate changes per DCR.

TABLE OF CONTENTS

1	GENERAL	5
1.1	SCOPE	5
1.2	APPLICABLE DOCUMENTS	5
1.3	TERMS, DEFINITIONS, ABBREVIATIONS, SYMBOLS AND UNITS	5
1.4	THE ESCC COMPONENT NUMBER AND COMPONENT TYPE VARIANTS	5
1.4.1	The ESCC Component Number	5
1.4.2	Component Type Variants and Range of Components	6
1.5	MAXIMUM RATINGS	9
1.6	PHYSICAL DIMENSIONS	10
1.6.1	Case Type BR with Radial Leads	10
1.6.2	Case Type CV with Radial Leads	11
1.6.3	Case Type CH with Straight DIL Leads	12
1.6.4	Case Type CH with L DIL Leads	14
1.7	FUNCTIONAL DIAGRAM	15
2	REQUIREMENTS	16
2.1	GENERAL	16
2.1.1	Deviations from the Generic Specification	16
2.2	MARKING	16
2.3	ROBUSTNESS OF TERMINATIONS	16
2.4	ELECTRICAL MEASUREMENTS AT ROOM, HIGH AND LOW TEMPERATURES	17
2.4.1	Room Temperature Electrical Measurements	17
2.4.2	High and Low Temperatures Electrical Measurements	17
2.5	INTERMEDIATE AND END-POINT ELECTRICAL MEASUREMENTS	18
2.6	BURN-IN	19
	APPENDIX A	20

1 GENERAL

1.1 SCOPE

This specification details the ratings, physical and electrical characteristics, and test and inspection data for the component type variants and/or the range of components specified below. It supplements the requirements of, and shall be read in conjunction with, the ESCC Generic Specification listed under Applicable Documents.

1.2 APPLICABLE DOCUMENTS

The following documents form part of this specification and shall be read in conjunction with it:

- (a) ESCC Generic Specification No. [3001](#).

1.3 TERMS, DEFINITIONS, ABBREVIATIONS, SYMBOLS AND UNITS

For the purpose of this specification, the terms, definitions, abbreviations, symbols and units specified in ESCC Basic Specification No. [21300](#) shall apply.

1.4 THE ESCC COMPONENT NUMBER AND COMPONENT TYPE VARIANTS

1.4.1 The ESCC Component Number

The ESCC Component Number shall be constituted as follows:

Example: 300103001476KE

- Detail Specification Reference: 3001030
- Component Type Variant Number: 01 (as required)
- Characteristic code: Capacitance Value (47 μ F): 476 (as required)
- Characteristic code: Capacitance Tolerance (\pm 10%): K (as required)
- Rating code: Rated Voltage (100V): E (as required)

1.4.1.1 *Characteristics and Ratings Codes*

Characteristics and ratings to be codified as part of the ESCC Component Number shall be as follows:

- (a) Rated Capacitance Value C_n expressed by means of the following codes in accordance with ESCC Basic Specification No. [21700](#). The unit quantity shall be picofarad (pF).

Capacitance Value C_n (pF)	Code
XX 10 ⁴	XX4
XX 10 ⁵	XX5
XX 10 ⁶	XX6
XX 10 ⁷	XX7

- (b) Capacitance Tolerance expressed by the following codes in accordance with ESCC Basic Specification No. 21700:

Tolerance (± %)	Code Letter
10	K
20	M

- (c) Rated Voltage expressed by the following codes:

Rated Voltage (V)	Code Letter
50	C
100	E
200	G
500	L

1.4.2 Component Type Variants and Range of Components

The component type variants and range of components applicable to this specification are as follows:

Variant Number	Package Details (Note 1)				Capacitance Range C _n (μF) (Note 4)				Weight Max (g)
	Case Type (Note 2)	Lead Type	No. of Leads	Lead Mat. & Fin. (Note 3)	Rated Voltage U _R = 50V	Rated Voltage U _R = 100V	Rated Voltage U _R = 200V	Rated Voltage U _R = 500V	
01	BR40	Radial	2	A3	1.8 to 3.3	1.2 to 2.7	0.33 to 0.56	0.12 to 0.22	2
02	BR50	Radial	2	A3	3.9 to 5.6	2.2 to 3.9	0.68 to 1	0.27 to 0.39	3
03	BR66	Radial	2	A3	6.8 to 10	4.7 to 8.2	1 to 2.2	0.47 to 1	5
04	BR72	Radial	2	A3	12 to 18	8.2 to 15	2.2 to 3.3	0.82 to 1.5	8
05	BR84	Radial	2	A3	12 to 18	8.2 to 15	2.2 to 3.3	0.82 to 1.5	8
06	CV41	Radial	2	A3	1.8 to 3.3	1.2 to 2.7	0.33 to 0.56	0.12 to 0.22	2
07	CH41	Straight DIL	6	N9	1.8 to 3.3	1.2 to 2.7	0.33 to 0.56	0.12 to 0.22	2
08	CH41	L DIL	6	N9	1.8 to 3.3	1.2 to 2.7	0.33 to 0.56	0.12 to 0.22	2
09	CH42	Straight DIL	6	N9	3.9 to 6.8	3.3 to 5.6	0.68 to 1.2	0.27 to 0.47	4
10	CH42	L DIL	6	N9	3.9 to 6.8	3.3 to 5.6	0.68 to 1.2	0.27 to 0.47	4
11	CH43	Straight DIL	6	N9	8.2 to 10	6.8 to 8.2	1.5 to 1.8	0.56 to 0.68	6
12	CH43	L DIL	6	N9	8.2 to 10	6.8 to 8.2	1.5 to 1.8	0.56 to 0.68	6
13	CH44	Straight DIL	6	N9	12	10	2.2	0.82 to 1	8
14	CH44	L DIL	6	N9	12	10	2.2	0.82 to 1	8
15	CV51	Radial	2	A3	3.9 to 5.6	2.2 to 3.9	0.68 to 1	0.27 to 0.39	3
16	CH51	Straight DIL	8	N9	3.9 to 5.6	2.2 to 3.9	0.68 to 1	0.27 to 0.39	3
17	CH51	L DIL	8	N9	3.9 to 5.6	2.2 to 3.9	0.68 to 1	0.27 to 0.39	3
18	CH52	Straight DIL	8	N9	6.8 to 10	4.7 to 8.2	1 to 2.2	0.47 to 0.82	6
19	CH52	L DIL	8	N9	6.8 to 10	4.7 to 8.2	1 to 2.2	0.47 to 0.82	6

Variant Number	Package Details (Note 1)				Capacitance Range C _n (μF) (Note 4)				Weight Max (g)
	Case Type (Note 2)	Lead Type	No. of Leads	Lead Mat. & Fin. (Note 3)	Rated Voltage U _R = 50V	Rated Voltage U _R = 100V	Rated Voltage U _R = 200V	Rated Voltage U _R = 500V	
20	CH53	Straight DIL	8	N9	12 to 15	10 to 12	2.7 to 3.3	1 to 1.2	9
21	CH53	L DIL	8	N9	12 to 15	10 to 12	2.7 to 3.3	1 to 1.2	9
22	CH54	Straight DIL	8	N9	18 to 22	15	3.9	1.5	12
23	CH54	L DIL	8	N9	18 to 22	15	3.9	1.5	12
24	CV61	Radial	2	A3	6.8 to 10	4.7 to 8.2	1 to 2.2	0.47 to 1	5
25	CH61	Straight DIL	10	N9	6.8 to 10	4.7 to 8.2	1 to 2.2	0.47 to 1	5
26	CH61	L DIL	10	N9	6.8 to 10	4.7 to 8.2	1 to 2.2	0.47 to 1	5
27	CH62	Straight DIL	10	N9	12 to 22	10 to 15	2.7 to 4.7	1 to 1.8	10
28	CH62	L DIL	10	N9	12 to 22	10 to 15	2.7 to 4.7	1 to 1.8	10
29	CH63	Straight DIL	10	N9	27 to 33	18 to 22	5.6 to 6.8	2.2 to 2.7	15
30	CH63	L DIL	10	N9	27 to 33	18 to 22	5.6 to 6.8	2.2 to 2.7	15
31	CH64	Straight DIL	10	N9	39	27 to 33	8.2 to 10	3.3	20
32	CH64	L DIL	10	N9	39	27 to 33	8.2 to 10	3.3	20
33	CV71	Radial	2	A3	12 to 18	8.2 to 15	2.2 to 3.3	0.82 to 1.5	8
34	CH71	Straight DIL	14	N9	12 to 18	8.2 to 15	2.2 to 3.3	0.82 to 1.5	8
35	CH71	L DIL	14	N9	12 to 18	8.2 to 15	2.2 to 3.3	0.82 to 1.5	8
36	CH72	Straight DIL	14	N9	22 to 39	18 to 27	3.9 to 6.8	1.8 to 3.3	16
37	CH72	L DIL	14	N9	22 to 39	18 to 27	3.9 to 6.8	1.8 to 3.3	16
38	CH73	Straight DIL	14	N9	47 to 56	33 to 39	8.2 to 10	3.9 to 4.7	24
39	CH73	L DIL	14	N9	47 to 56	33 to 39	8.2 to 10	3.9 to 4.7	24
40	CH74	Straight DIL	14	N9	68	47	12	5.6	32
41	CH74	L DIL	14	N9	68	47	12	5.6	32
42	CV76	Radial	2	A3	12 to 18	8.2 to 15	2.2 to 3.3	0.82 to 1.5	8
43	CH76	Straight DIL	12	N9	12 to 18	8.2 to 15	2.2 to 3.3	0.82 to 1.5	8
44	CH76	L DIL	12	N9	12 to 18	8.2 to 15	2.2 to 3.3	0.82 to 1.5	8
45	CH77	Straight DIL	12	N9	22 to 39	18 to 27	3.9 to 6.8	1.8 to 3.3	16
46	CH77	L DIL	12	N9	22 to 39	18 to 27	3.9 to 6.8	1.8 to 3.3	16
47	CH78	Straight DIL	12	N9	47 to 56	33 to 39	8.2 to 10	3.9 to 4.7	24
48	CH78	L DIL	12	N9	47 to 56	33 to 39	8.2 to 10	3.9 to 4.7	24
49	CH79	Straight DIL	12	N9	68	47	12	5.6	32
50	CH79	L DIL	12	N9	68	47	12	5.6	32
51	CH81	Straight DIL	28	N9	15 to 22	12 to 18	2.2 to 3.9	0.82 to 1.5	10
52	CH81	L DIL	28	N9	15 to 22	12 to 18	2.2 to 3.9	0.82 to 1.5	10
53	CH82	Straight DIL	28	N9	27 to 47	22 to 39	4.7 to 8.2	1.8 to 3.3	20
54	CH82	L DIL	28	N9	27 to 47	22 to 39	4.7 to 8.2	1.8 to 3.3	20

Variant Number	Package Details (Note 1)				Capacitance Range C _n (μF) (Note 4)				Weight Max (g)
	Case Type (Note 2)	Lead Type	No. of Leads	Lead Mat. & Fin. (Note 3)	Rated Voltage U _R = 50V	Rated Voltage U _R = 100V	Rated Voltage U _R = 200V	Rated Voltage U _R = 500V	
55	CH83	Straight DIL	28	N9	56 to 68	47 to 56	10 to 12	3.9 to 4.7	30
56	CH83	L DIL	28	N9	56 to 68	47 to 56	10 to 12	3.9 to 4.7	30
57	CH84	Straight DIL	28	N9	82	68	15	5.6	40
58	CH84	L DIL	28	N9	82	68	15	5.6	40
59	CH86	Straight DIL	28	N9	22 to 33	15 to 27	3.9 to 6.8	1.5 to 2.2	14
60	CH86	L DIL	28	N9	22 to 33	15 to 27	3.9 to 6.8	1.5 to 2.2	14
61	CH87	Straight DIL	28	N9	39 to 68	33 to 56	8.2 to 15	2.7 to 4.7	28
62	CH87	L DIL	28	N9	39 to 68	33 to 56	8.2 to 15	2.7 to 4.7	28
63	CH88	Straight DIL	28	N9	82 to 100	68 to 82	18 to 22	5.6 to 6.8	42
64	CH88	L DIL	28	N9	82 to 100	68 to 82	18 to 22	5.6 to 6.8	42
65	CH89	Straight DIL	28	N9	120	100	27	8.2	56
66	CH89	L DIL	28	N9	120	100	27	8.2	56
67	CH91	Straight DIL	28	N9	39 to 47	33 to 39	8.2 to 10	2.7 to 4.7	19
68	CH91	L DIL	28	N9	39 to 47	33 to 39	8.2 to 10	2.7 to 4.7	19
69	CH92	Straight DIL	28	N9	56 to 100	47 to 82	12 to 22	5.6 to 10	38
70	CH92	L DIL	28	N9	56 to 100	47 to 82	12 to 22	5.6 to 10	38
71	CH93	Straight DIL	28	N9	120 to 150	100 to 120	27 to 33	12 to 15	57
72	CH93	L DIL	28	N9	120 to 150	100 to 120	27 to 33	12 to 15	57
73	CH94	Straight DIL	28	N9	180	150	39	18	76
74	CH94	L DIL	28	N9	180	150	39	18	76

NOTES:

1. See Physical Dimensions.
2. For Variants 01 to 05 (case type BR) the body shall be coated with epoxy resin. Variants 06 to 74 (case types CV & CH) are classified as non-insulated.
3. The lead material and finishes shall be in accordance with the requirements of ESCC Basic Specification No. [23500](#).
4. Available capacitance values and tolerances are as follows:
 - Tolerance: ±10%; value series: E12
 - Tolerance: ±20%; value series: E12

1.5 MAXIMUM RATINGS

The maximum ratings shall not be exceeded at any time during use or storage.

Maximum ratings shall only be exceeded during testing to the extent specified in this specification and when stipulated in Test Methods and Procedures of the ESCC Generic Specification.

Characteristics	Symbols	Maximum Ratings	Units	Remarks
Rated Voltage	U_R	50, 100, 200, 500	V	Note 1
Operating Temperature Range	T_{op}	-55 to +125	°C	Without derating. T_{amb}
Storage Temperature Range	T_{stg}	-55 to +125	°C	
Soldering Temperature	T_{sol}	+260	°C	Note 2

NOTES:

1. As required; See Component Type Variants and Range of Components.
2. Duration 5 seconds maximum at a distance of not less than 1.5mm from the body and the same lead shall not be resoldered until 3 minutes have elapsed.

1.6 PHYSICAL DIMENSIONS

1.6.1 Case Type BR with Radial Leads

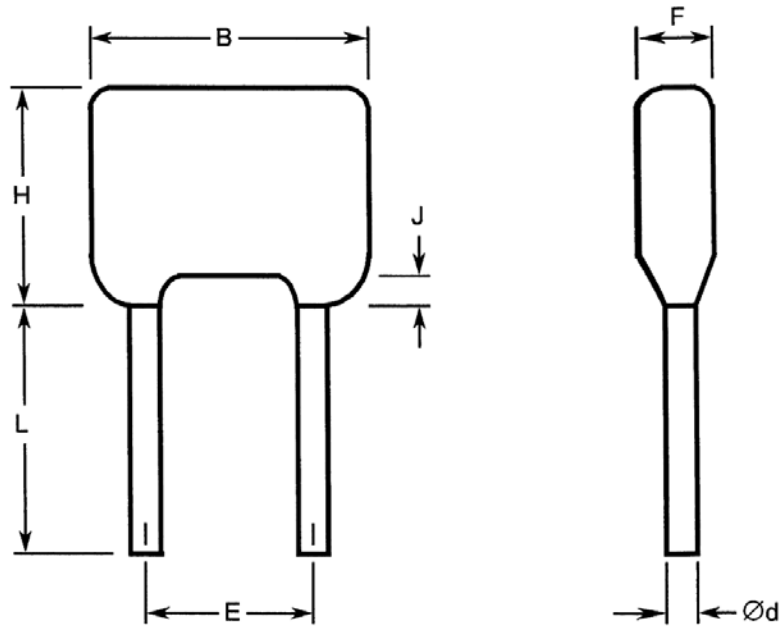

Variant Number	Case Type	Dimensions (mm)								
		B Max	Ød (Note 1)		E		F Max	H Max	J Max	L Min (Note 1)
			Min	Max	Min	Max				
01	BR40	10.16	0.46	0.56	4.58	5.58	5	11.7	1.5	31.7
02	BR50	12.7	0.59	0.69	9.66	10.66	5.1	14.2	1.5	31.7
03	BR66	17.5	0.86	0.96	14.2	15.2	6.4	16.5	1.5	31.7
04	BR72	19.3	0.86	0.96	14.74	15.74	6.4	24	1.5	31.7
05	BR84	23.62	0.71	0.81	18.93	20.83	6.4	19.78	1.5	31.7

NOTES:

- Both leads.

1.6.2 Case Type CV with Radial Leads

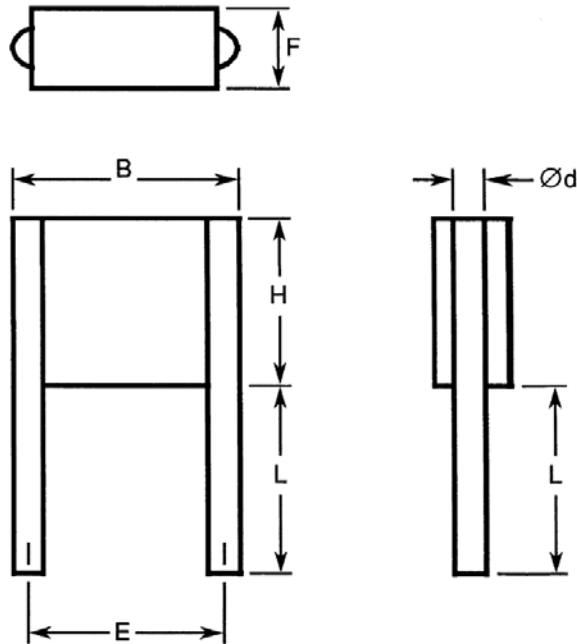

Variant Number	Case Type	Dimensions (mm)								
		B Max	Ød (Note 1)		E		F Max	H Max	L (Note 1)	
			Min	Max	Min	Max			Min	Max
06	CV41	10.6	0.65	0.75	7.7	8.7	3.8	8.7	22	28
15	CV51	11.9	0.85	0.95	9.66	10.66	3.8	10.7	22	28
24	CV61	16.5	0.85	0.95	14.74	15.74	3.8	13.6	22	28
33	CV71	17.8	0.85	0.95	14.74	15.74	3.8	21.6	22	28
42	CV76	22.7	0.85	0.95	20.4	22	3.8	16.6	22	28

NOTES:

- Both leads.

1.6.3 Case Type CH with Straight DIL Leads

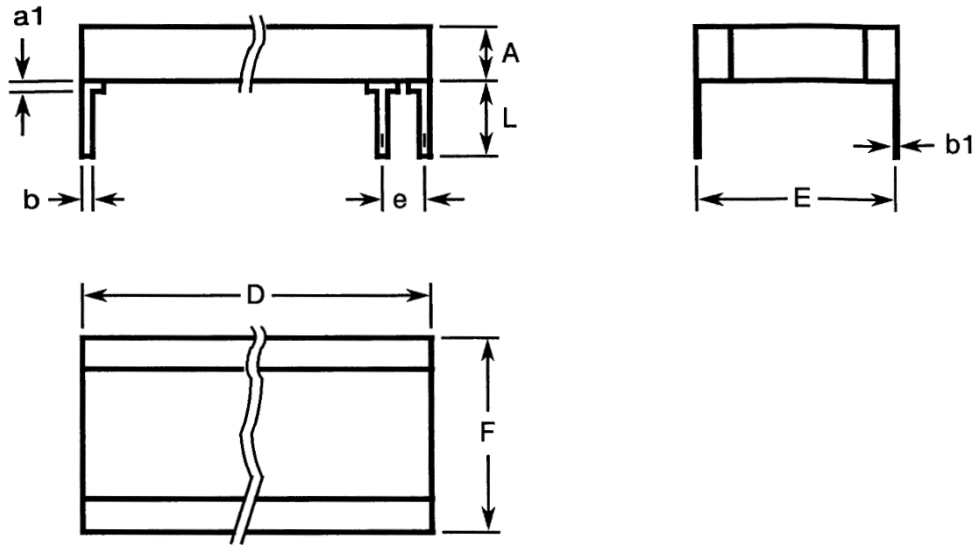

Variant Number	Case Type	Dimensions (mm)													
		A Max	a1 Max (Note 1)	b (Note 1)		b1 (Note 1)		D Max	E (Note 1)		e (Note 1)		F Max	L (Note 1)	
				Min	Max	Min	Max		Min	Max	Min	Max		Min	Max
07	CH41	3.8	2	0.45	0.55	0.204	0.304	8.7	7.7	8.7	2.49	2.59	9.2	12	14
09	CH42	7.4	2	0.45	0.55	0.204	0.304	8.7	7.7	8.7	2.49	2.59	9.2	12	14
11	CH43	11.1	2	0.45	0.55	0.204	0.304	8.7	7.7	8.7	2.49	2.59	9.2	12	14
13	CH44	14.8	2	0.45	0.55	0.204	0.304	8.7	7.7	8.7	2.49	2.59	9.2	12	14
16	CH51	3.8	2	0.45	0.55	0.204	0.304	10.7	9.66	10.66	2.49	2.59	10.7	12	14
18	CH52	7.4	2	0.45	0.55	0.204	0.304	10.7	9.66	10.66	2.49	2.59	10.7	12	14
20	CH53	11.1	2	0.45	0.55	0.204	0.304	10.7	9.66	10.66	2.49	2.59	10.7	12	14
22	CH54	14.8	2	0.45	0.55	0.204	0.304	10.7	9.66	10.66	2.49	2.59	10.7	12	14
25	CH61	3.8	2	0.45	0.55	0.204	0.304	13.6	13.5	14.5	2.49	2.59	14.9	12	14
27	CH62	7.4	2	0.45	0.55	0.204	0.304	13.6	13.5	14.5	2.49	2.59	14.9	12	14
29	CH63	11.1	2	0.45	0.55	0.204	0.304	13.6	13.5	14.5	2.49	2.59	14.9	12	14
31	CH64	14.8	2	0.45	0.55	0.204	0.304	13.6	13.5	14.5	2.49	2.59	14.9	12	14
34	CH71	3.8	2	0.45	0.55	0.204	0.304	21.6	14.74	15.74	2.49	2.59	16.8	12	14
36	CH72	7.4	2	0.45	0.55	0.204	0.304	21.6	14.74	15.74	2.49	2.59	16.8	12	14
38	CH73	11.1	2	0.45	0.55	0.204	0.304	21.6	14.74	15.74	2.49	2.59	16.8	12	14
40	CH74	14.8	2	0.45	0.55	0.204	0.304	21.6	14.74	15.74	2.49	2.59	16.8	12	14
43	CH76	3.8	2	0.45	0.55	0.204	0.304	16.6	19.52	21.12	2.49	2.59	21.6	12	14
45	CH77	7.4	2	0.45	0.55	0.204	0.304	16.6	19.52	21.12	2.49	2.59	21.6	12	14
47	CH78	11.1	2	0.45	0.55	0.204	0.304	16.6	19.52	21.12	2.49	2.59	21.6	12	14

Variant Number	Case Type	Dimensions (mm)													
		A Max	a1 Max (Note 1)	b (Note 1)		b1 (Note 1)		D Max	E (Note 1)		e (Note 1)		F Max	L (Note 1)	
				Min	Max	Min	Max		Min	Max	Min	Max		Min	Max
49	CH79	14.8	2	0.45	0.55	0.204	0.304	16.6	19.52	21.12	2.49	2.59	21.6	12	14
51	CH81	3.8	2	0.45	0.55	0.204	0.304	38.2	9.66	10.66	2.49	2.59	12	12	14
53	CH82	7.4	2	0.45	0.55	0.204	0.304	38.2	9.66	10.66	2.49	2.59	12	12	14
55	CH83	11.1	2	0.45	0.55	0.204	0.304	38.2	9.66	10.66	2.49	2.59	12	12	14
57	CH84	14.8	2	0.45	0.55	0.204	0.304	38.2	9.66	10.66	2.49	2.59	12	12	14
59	CH86	3.8	2	0.45	0.55	0.204	0.304	38.2	14.74	15.74	2.49	2.59	18.9	12	14
61	CH87	7.4	2	0.45	0.55	0.204	0.304	38.2	14.74	15.74	2.49	2.59	18.9	12	14
63	CH88	11.1	2	0.45	0.55	0.204	0.304	38.2	14.74	15.74	2.49	2.59	18.9	12	14
65	CH89	14.8	2	0.45	0.55	0.204	0.304	38.2	14.74	15.74	2.49	2.59	18.9	12	14
67	CH91	3.8	2	0.45	0.55	0.204	0.304	40.6	19.52	21.12	2.49	2.59	24	12	14
69	CH92	7.4	2	0.45	0.55	0.204	0.304	40.6	19.52	21.12	2.49	2.59	24	12	14
71	CH93	11.1	2	0.45	0.55	0.204	0.304	40.6	19.52	21.12	2.49	2.59	24	12	14
73	CH94	14.8	2	0.45	0.55	0.204	0.304	40.6	19.52	21.12	2.49	2.59	24	12	14

NOTES:

1. All leads.

1.6.4 Case Type CH with L DIL Leads

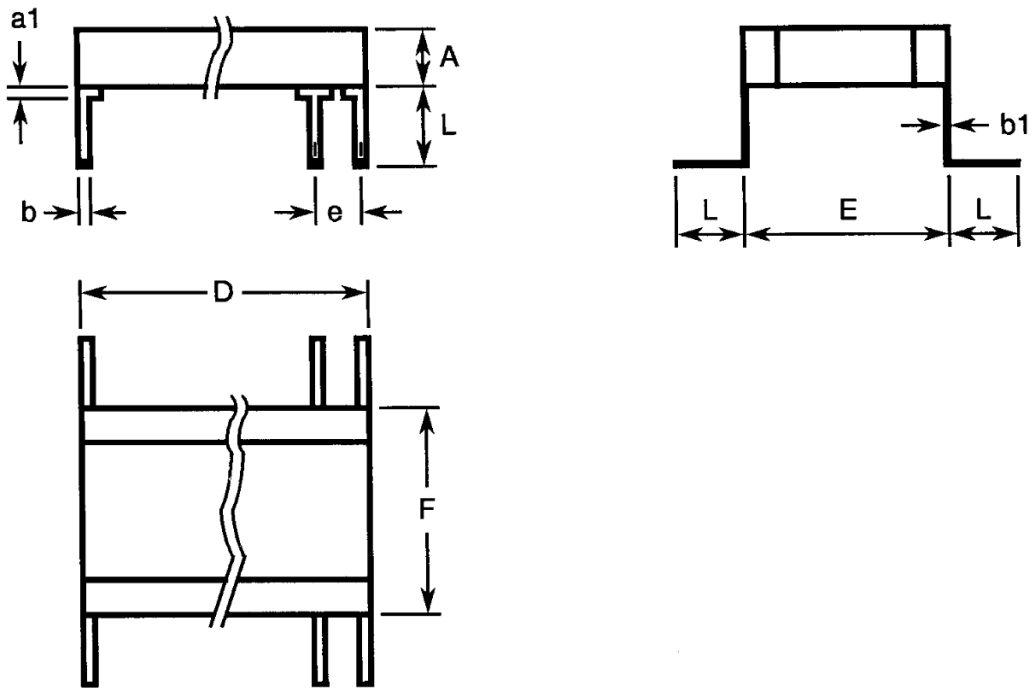

Variant Number	Case Type	Dimensions (mm)													
		A Max	a1 Max (Note 1)	b (Note 1)		b1 (Note 1)		D Max	E (Note 1)		e (Note 1)		F Max	L (Note 1)	
				Min	Max	Min	Max		Min	Max	Min	Max			
08	CH41	3.8	2	0.45	0.55	0.204	0.304	8.7	7.7	8.7	2.49	2.59	9.2	2.04	3.04
10	CH42	7.4	2	0.45	0.55	0.204	0.304	8.7	7.7	8.7	2.49	2.59	9.2	2.04	3.04
12	CH43	11.1	2	0.45	0.55	0.204	0.304	8.7	7.7	8.7	2.49	2.59	9.2	2.04	3.04
14	CH44	14.8	2	0.45	0.55	0.204	0.304	8.7	7.7	8.7	2.49	2.59	9.2	2.04	3.04
17	CH51	3.8	2	0.45	0.55	0.204	0.304	10.7	9.66	10.66	2.49	2.59	10.7	2.04	3.04
19	CH52	7.4	2	0.45	0.55	0.204	0.304	10.7	9.66	10.66	2.49	2.59	10.7	2.04	3.04
21	CH53	11.1	2	0.45	0.55	0.204	0.304	10.7	9.66	10.66	2.49	2.59	10.7	2.04	3.04
23	CH54	14.8	2	0.45	0.55	0.204	0.304	10.7	9.66	10.66	2.49	2.59	10.7	2.04	3.04
26	CH61	3.8	2	0.45	0.55	0.204	0.304	13.6	13.5	14.5	2.49	2.59	14.9	2.04	3.04
28	CH62	7.4	2	0.45	0.55	0.204	0.304	13.6	13.5	14.5	2.49	2.59	14.9	2.04	3.04
30	CH63	11.1	2	0.45	0.55	0.204	0.304	13.6	13.5	14.5	2.49	2.59	14.9	2.04	3.04
32	CH64	14.8	2	0.45	0.55	0.204	0.304	13.6	13.5	14.5	2.49	2.59	14.9	2.04	3.04
35	CH71	3.8	2	0.45	0.55	0.204	0.304	21.6	14.74	15.74	2.49	2.59	16.8	2.04	3.04
37	CH72	7.4	2	0.45	0.55	0.204	0.304	21.6	14.74	15.74	2.49	2.59	16.8	2.04	3.04
39	CH73	11.1	2	0.45	0.55	0.204	0.304	21.6	14.74	15.74	2.49	2.59	16.8	2.04	3.04
41	CH74	14.8	2	0.45	0.55	0.204	0.304	21.6	14.74	15.74	2.49	2.59	16.8	2.04	3.04
44	CH76	3.8	2	0.45	0.55	0.204	0.304	16.6	19.52	21.12	2.49	2.59	21.6	2.04	3.04

Variant Number	Case Type	Dimensions (mm)													
		A Max	a1 Max (Note 1)	b (Note 1)		b1 (Note 1)		D Max	E (Note 1)		e (Note 1)		F Max	L (Note 1)	
				Min	Max	Min	Max		Min	Max	Min	Max		Min	Max
46	CH77	7.4	2	0.45	0.55	0.204	0.304	16.6	19.52	21.12	2.49	2.59	21.6	2.04	3.04
48	CH78	11.1	2	0.45	0.55	0.204	0.304	16.6	19.52	21.12	2.49	2.59	21.6	2.04	3.04
50	CH79	14.8	2	0.45	0.55	0.204	0.304	16.6	19.52	21.12	2.49	2.59	21.6	2.04	3.04
52	CH81	3.8	2	0.45	0.55	0.204	0.304	38.2	9.66	10.66	2.49	2.59	12	2.04	3.04
54	CH82	7.4	2	0.45	0.55	0.204	0.304	38.2	9.66	10.66	2.49	2.59	12	2.04	3.04
56	CH83	11.1	2	0.45	0.55	0.204	0.304	38.2	9.66	10.66	2.49	2.59	12	2.04	3.04
58	CH84	14.8	2	0.45	0.55	0.204	0.304	38.2	9.66	10.66	2.49	2.59	12	2.04	3.04
60	CH86	3.8	2	0.45	0.55	0.204	0.304	38.2	14.74	15.74	2.49	2.59	18.9	2.04	3.04
62	CH87	7.4	2	0.45	0.55	0.204	0.304	38.2	14.74	15.74	2.49	2.59	18.9	2.04	3.04
64	CH88	11.1	2	0.45	0.55	0.204	0.304	38.2	14.74	15.74	2.49	2.59	18.9	2.04	3.04
66	CH89	14.8	2	0.45	0.55	0.204	0.304	38.2	14.74	15.74	2.49	2.59	18.9	2.04	3.04
68	CH91	3.8	2	0.45	0.55	0.204	0.304	40.6	19.52	21.12	2.49	2.59	24	2.04	3.04
70	CH92	7.4	2	0.45	0.55	0.204	0.304	40.6	19.52	21.12	2.49	2.59	24	2.04	3.04
72	CH93	11.1	2	0.45	0.55	0.204	0.304	40.6	19.52	21.12	2.49	2.59	24	2.04	3.04
74	CH94	14.8	2	0.45	0.55	0.204	0.304	40.6	19.52	21.12	2.49	2.59	24	2.04	3.04

NOTES:

1. All leads.

1.7 FUNCTIONAL DIAGRAM



NOTES:

1. For case type CH, all leads on each side of the component are connected to the same capacitor terminal.

2 REQUIREMENTS

2.1 GENERAL

The complete requirements for procurement of the components specified herein are as stated in this specification and the ESCC Generic Specification. Permitted deviations from the Generic Specification, applicable to this specification only, are listed below.

Permitted deviations from the Generic Specification and this Detail Specification, formally agreed with specific Manufacturers on the basis that the alternative requirements are equivalent to the ESCC requirement and do not affect the component's reliability, are listed in the appendices attached to this specification.

2.1.1 Deviations from the Generic Specification

2.1.1.1 *Deviations from Special In-Process Controls (Chart F2)*

- (a) Robustness of Terminations: Shall be replaced with a lead peel test as specified in Robustness of Terminations herein.

2.2 MARKING

The marking shall be in accordance with the requirements of ESCC Basic Specification No. 21700 and as follows.

The information to be marked on the component shall be:

- (a) The ESCC qualified components symbol (for ESCC qualified components only).
- (b) The ESCC Component Number.
- (c) Traceability information.

2.3 ROBUSTNESS OF TERMINATIONS

The terminations of these devices are classified as rigid.

Robustness of Terminations shall be performed as a lead peel test on a sample of 5 components from each manufacturing lot with 0 failures allowed. The sample components shall be leaded but not encapsulated or coated. Where necessary, the leads of the component under test shall be bent through 90° in the plane of the joint such that a tensile force applied to the leads will result in a peeling force being applied to the leads' joint.

A tensile force shall be applied evenly across the length, on the capacitor terminal, to all leads on that side of the component together, until the lead joint peels. All leads shall be tested.

The minimum peeling force shall be as follows:

- For case types BR & CV: 8.9N
- For case type CH: 22.25N

2.4 ELECTRICAL MEASUREMENTS AT ROOM, HIGH AND LOW TEMPERATURES

Electrical measurements shall be performed at room, high and low temperatures.

2.4.1 Room Temperature Electrical Measurements

The measurements shall be performed at $T_{amb} = +22 \pm 3^{\circ}\text{C}$.

Characteristics	Symbols	Test Method and Conditions	Tolerance (\pm %)	Limits		Units
				Min	Max	
Capacitance (Note 1)	C_A	ESCC No. 3001	10 20	$0.9C_n$ $0.8C_n$	$1.1C_n$ $1.2C_n$	μF
Tangent of Loss Angle	$\text{tg}\delta$	ESCC No. 3001	All	-	250×10^{-4}	-
Insulation Resistance (Dielectric)	R_{ID}	ESCC No. 3001	All	1000	-	$\text{G}\Omega.\text{nF}$
Insulation Resistance (Body Insulation)	R_{IB}	ESCC No. 3001 Case type BR only Note 2	All	1000	-	$\text{G}\Omega.\text{nF}$
Voltage Proof (Dielectric)	VP_D	ESCC No. 3001 For $U_R < 500\text{V}$ For $U_R = 500\text{V}$	All	$2.5U_R$ $2U_R$	- -	V
Voltage Proof (Body Insulation)	VP_B	ESCC No. 3001 Case type BR only Note 2 For $U_R < 500\text{V}$ For $U_R = 500\text{V}$	All	$2.5U_R$ $2U_R$	- -	V

NOTES:

1. Capacitance limits may be adjusted to take into account capacitance ageing, as specified in the Generic Specification.
2. The measurements shall be performed on a sample of 5 components from each manufacturing lot with 0 failures allowed. In the event of any failure a 100% inspection may be performed. In the case of a 100% inspection, a 1% total percent defective is allowed.

2.4.2 High and Low Temperatures Electrical Measurements

Characteristics	Symbols	Test Method and Conditions (Note 1)	Limits		Units
			Min	Max	
Temperature Characteristic	TC	ESCC No. 3001 $T_{amb} = -55 \pm 2^{\circ}\text{C}, +20 \pm 2^{\circ}\text{C}, +125 \pm 2^{\circ}\text{C}$ Note 2 For $V_T = \text{no voltage applied}$ For $V_T = U_R$	-20 -50	+20 +30	%

NOTES:

1. The measurements shall be performed on a sample of 5 components from each manufacturing lot with 0 failures allowed. In the event of any failure a 100% inspection may be performed.
2. In the case of a 100% inspection, a 1% total percent defective is allowed.

2.5 INTERMEDIATE AND END-POINT ELECTRICAL MEASUREMENTS

Unless otherwise specified, the measurements shall be performed at $T_{amb} = +22 \pm 3^{\circ}\text{C}$.

Unless otherwise specified the test methods and test conditions shall be as per the corresponding test defined in Room Temperature Electrical Measurements.

Test Reference per ESCC No. 3001	Characteristics	Symbols	Limits		Units	
			Min	Max		
Rapid Change of Temperature Initial Measurements	Capacitance	C_A	Note 1			
	Final Measurements	C_A	Note 1			
	Change in Capacitance	$\Delta C_A/C_A$	-10	+10	%	
	Tangent of Loss Angle	$\text{tg}\delta$	-	500×10^{-4}	-	
Steady State Humidity Initial Measurements	Capacitance	C_A	Note 1			
	Final Measurements	C_A	Note 1			
	Change in Capacitance	$\Delta C_A/C_A$	-10	+10	%	
	Tangent of Loss Angle	$\text{tg}\delta$	-	500×10^{-4}	-	
	Insulation Resistance (Dielectric) Note 2	R_{ID}	30	-	$\text{G}\Omega.\text{nF}$	
	Insulation Resistance (Body Insulation) Notes 2, 3	R_{IB}	30	-	$\text{G}\Omega.\text{nF}$	
Operating Life Initial Measurements	Capacitance	C_A	Note 1			
	Intermediate Measurements (1000 hours) (Note 4)	Capacitance	C_A	Note 1		
		Change in Capacitance	$\Delta C_A/C_A$	-15	+15	%
		Insulation Resistance (Dielectric) Note 2	R_{ID}	100	-	$\text{G}\Omega.\text{nF}$
		Insulation Resistance (Body Insulation) Notes 2, 3	R_{IB}	100	-	$\text{G}\Omega.\text{nF}$
	Final Measurements (1000 or 2000 hours) (Note 5)	Capacitance	C_A	Note 1		
		Change in Capacitance	$\Delta C_A/C_A$	-15	+15	%
		Tangent of Loss Angle	$\text{tg}\delta$	-	500×10^{-4}	-
		Insulation Resistance (Dielectric) Note 2	R_{ID}	100	-	$\text{G}\Omega.\text{nF}$
		Insulation Resistance (Body Insulation) Notes 2, 3	R_{IB}	100	-	$\text{G}\Omega.\text{nF}$
Voltage Proof (Dielectric)		V_{PD}	Note 1			
Voltage Proof (Body Insulation) Note 2	V_{PB}	Note 1				

Test Reference per ESCC No. 3001	Characteristics	Symbols	Limits		Units
			Min	Max	
Capacitance-Temperature Characteristics	Temperature Characteristic	TC	Note 6		
Resistance to Soldering Heat					
Initial Measurements	Capacitance	C _A	Note 1		
Final Measurements	Capacitance	C _A	Note 1		
	Change in Capacitance	$\Delta C_A/C_A$	-15	+15	%
	Insulation Resistance (Dielectric) Note 2	R _{ID}	1000	-	GΩ.nF
	Insulation Resistance (Body Insulation) Notes 2, 3	R _{IB}	1000	-	GΩ.nF

NOTES:

1. As specified in Room Temperature Electrical Measurements.
2. Test conditions for Insulation Resistance shall be as specified in Steady State Humidity in the ESCC Generic Specification.
3. Case type BR only.
4. Intermediate measurements are optional at the Manufacturer's discretion.
5. 1000 hours is applicable to Periodic Testing for extension of qualification. 2000 hours is applicable to Qualification Testing, and to Periodic Testing for renewal of qualification after lapse.
6. As specified in High and Low Temperatures Electrical Measurements.

2.6

BURN-IN

The requirements for Burn-in are specified in the ESCC Generic Specification. The following conditions shall also apply:

- After Burn-in, the components shall be removed from the chamber and allowed to cool under normal atmospheric conditions for recovery for 24 hours minimum.

APPENDIX A
AGREED DEVIATIONS FOR AVX LTD (GB)

Items Affected	Description of Deviations
Deviations from Generic Specification: Special In-Process Controls (Chart F2)	Microsection Inspection: may be performed using AVX inspection document as per PID. Internal Visual Inspection: may be performed using AVX inspection document as per PID.
Deviations from Generic Specification: Screening (Chart F3)	External Visual Inspection: may be performed using AVX inspection document as per PID.
Deviations from Generic Specification: Qualification and Periodic Tests (Chart F4)	External Visual Inspection: may be performed using AVX inspection document as per PID.