

SHELL TYPES 06 & 66: PLUG

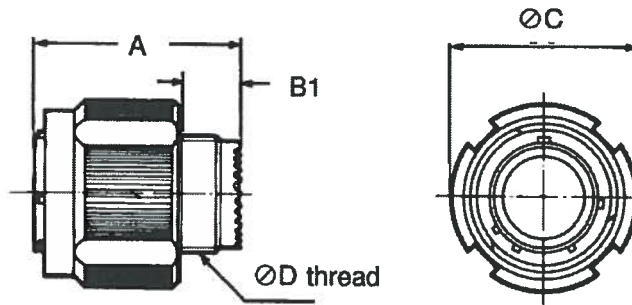

Shell Size	09		11		13		15		17		19		21		23		25	
	Min	Max	Min	Max	Min	Max	Min	Max	Min	Max	Min	Max	Min	Max	Min	Max	Min	Max
A	-	31	-	31	-	31	-	31	-	31	-	31	-	31	-	31	-	31
B1	7.12	-	7.12	-	7.12	-	7.12	-	7.12	-	7.12	-	7.12	-	7.12	-	7.12	-
ØC	-	21.8	-	25	-	29.4	-	32.5	-	35.7	-	38.5	-	41.7	-	44.85	-	48
ØD	M 12 × 1-6g		M 15 × 1-6g		M 18 × 1-6g		M 22 × 1-6g		M 25 × 1-6g		M 28 × 1-6g		M 31 × 1-6g		M 34 × 1-6g		M 37 × 1-6g	

SHELL TYPE 07: SINGLE HOLE MOUNTING RECEPTACLE

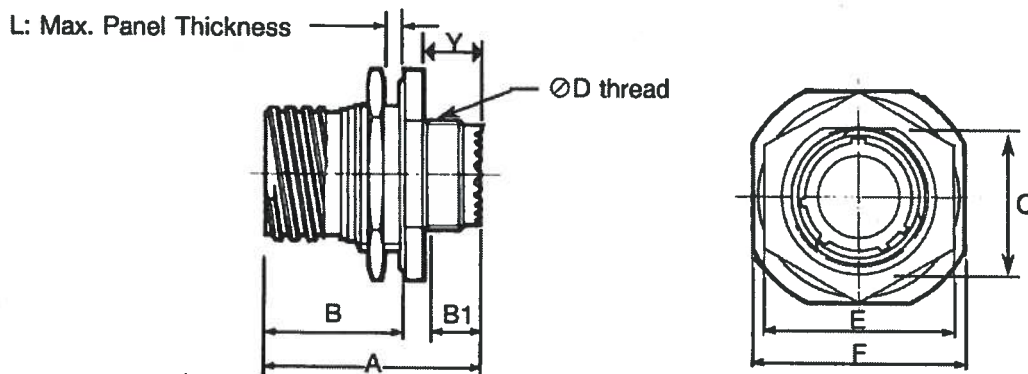

Shell Size	09		11		13		15		17		19		21		23		25	
	Min	Max	Min	Max	Min	Max	Min	Max	Min	Max	Min	Max	Min	Max	Min	Max	Min	Max
A	-	32.5	-	32.5	-	32.5	-	32.5	-	32.5	-	32.5	-	32.5	-	32.5	-	32.5
B1	7.12	7.62	7.12	7.62	7.12	7.62	7.12	7.62	7.12	7.62	7.12	7.62	7.12	7.62	7.12	7.62	7.12	7.62
B	-	22.6	-	22.6	-	22.6	-	22.6	-	22.6	-	22.6	-	22.6	-	22.6	-	22.6
C	16.38	16.63	18.92	19.17	23.67	23.92	26.82	27.07	30	30.25	33.17	33.42	36.35	36.6	39.52	39.77	42.7	42.95
ØD	M 12 × 1-6g		M 15 × 1-6g		M 18 × 1-6g		M 22 × 1-6g		M 25 × 1-6g		M 28 × 1-6g		M 31 × 1-6g		M 34 × 1-6g		M 37 × 1-6g	
E	-	24	-	27	-	32	-	36	-	37	-	41	-	46	-	50	-	51.23
F	26.6	27.4	31.4	32.2	34.5	35.3	37.7	38.5	40.9	41.7	45.6	46.4	48.8	49.6	52	52.8	55.2	56
L	-	3.2	-	3.2	-	3.2	-	3.2	-	3.2	-	3.2	-	3.2	-	3.2	-	3.2
Y	5.57	6.57	5.57	6.57	5.57	6.57	5.57	6.57	5.57	6.57	5.57	6.57	5.57	6.57	5.57	6.57	5.57	6.57

6,54 7,54 6,54 7,54 6,36 7,36 6,36 7,36 6,36 7,36 6,36 7,36 6,36 7,36 6,36 7,36 6,36 7,36

NOTES:

1. All dimensions are in millimetres.