



as applicable

Pages 1 to 14

## ACCESSORIES FOR CONNECTORS, MICROMINIATURE

3401/029 AND CONNECTOR SAVERS 3401/041

, 3401/077

ESCC Detail Specification No. 3401/032

Issue ~~X~~3 Draft A

November 2005



Document Custodian: European Space Agency - see <https://escies.org>

**LEGAL DISCLAIMER AND COPYRIGHT**

European Space Agency, Copyright © 200~~7~~<sup>8</sup>. All rights reserved.

The European Space Agency disclaims any liability or responsibility, to any person or entity, with respect to any loss or damage caused, or alleged to be caused, directly or indirectly by the use and application of this ESCC publication.

This publication, without the prior permission of the European Space Agency and provided that it is not used for a commercial purpose, may be:

- copied in whole, in any medium, without alteration or modification.
- copied in part, in any medium, provided that the ESCC document identification, comprising the ESCC symbol, document number and document issue, is removed.



**DOCUMENTATION CHANGE NOTICE**

(Refer to <https://escies.org> for ESCC DCR content)

DCR No.	CHANGE DESCRIPTION
TAB <del>1</del>	Specification upissued to include editorial and technical changes per DCRs.



**TABLE OF CONTENTS**

<b>1.</b>	<b><u>GENERAL</u></b>	<b><u>5</u></b>
1.1	Scope	5
1.2	Type Variants	5
1.3	Maximum Ratings	5
1.4	Parameter Derating Information	5
1.5	Physical Dimensions	5
1.6	Functional Diagram	5
<b>2.</b>	<b><u>APPLICABLE DOCUMENTS</u></b>	<b><u>12</u></b>
<b>3.</b>	<b><u>TERMS, DEFINITIONS, ABBREVIATIONS, SYMBOLS AND UNITS</u></b>	<b><u>12</u></b>
<b>4.</b>	<b><u>REQUIREMENTS</u></b>	<b><u>12</u></b>
4.1	General	12
4.2	Deviations from Generic Specification	13
4.2.1	Deviations from Special In-process Controls	13
4.2.2	Deviations from Final Production Tests (Chart II)	13
4.2.3	Deviations from Burn-in and Electrical Measurements (Chart III)	13
4.2.4	Deviations from Qualification, Environmental and Endurance Tests (Chart IV)	13
4.2.5	Deviations from Lot Acceptance Tests (Chart V)	13
4.3	Mechanical Requirements	13
4.3.1	Dimension Check	13
4.3.2	Weight	13
4.3.3	Torque Value	13
4.4	Materials and Finishes	13
4.4.1	Screw Lock Assemblies and Brackets	14
4.5	Marking	14
4.5.1	General	14
4.5.2	The ESCC Component Number	14
4.5.3	Traceability Information	14
4.6	Electrical Measurements	14
4.7	Screening Tests (Tables 4 and 5)	14
4.8	Environmental and Endurance Tests	14
[4.4.2	Interfacial Seals	#

re-number  
if/as required

1. GENERAL

1.1 SCOPE

This specification details the ratings, physical and electrical characteristics, test and inspection data of Accessories for Microminiature Connectors 3401/029 (Type MDM) ~~and~~ Connector Savers 3401/041 ~~x~~ and Microminiature Connectors with Removable Contacts 3401/077 (Type MDMA).

It shall be read in conjunction with:

- ESCC Generic Specification No. 3401, Connectors, Electrical, Circular and Rectangular.
- ESCC Detail Specification No. 3401/029, Connectors, Electrical, Rectangular, Microminiature, based on Type MDM.
- ESCC Detail Specification No. 3401/041, Connector Savers, Electrical, Rectangular, Microminiature, based on type MDM.

the requirements of which are supplemented herein.

1.2 TYPE VARIANTS

the different type variants of accessories specified herein are detailed in Figure 2.

1.3 MAXIMUM RATINGS

The maximum ratings, which shall not be exceeded at any time during use or storage, applicable to the accessories specified herein, are as scheduled in Table 1.

1.4 PARAMETER DERATING INFORMATION

Not applicable.

1.5 PHYSICAL DIMENSIONS

The physical dimensions of the accessories specified herein are shown in Figure 2.

1.6 FUNCTIONAL DIAGRAM

Not applicable.

**Table 1 - MAXIMUM RATINGS**

No.	Characteristics	Symbol	Maximum Ratings	Unit
1	Operating Temperature Range	T <sub>op</sub>	-55 to +125	°C
2	Storage Temperature Range	T <sub>stg</sub>	-55 to +125	°C
3	Torque Value	T	See Figure 2	Nm

**FIGURE 1**

Not applicable.

[ - ESCC Detail Specification No. 3401/077, Connectors, Electrical, Rectangular, Microminiature, Removable Contacts, based on type MDMA.

**FIGURE 2 - PHYSICAL DIMENSIONS**  
 Variants 03 and 04 - 90° Mounting Bracket

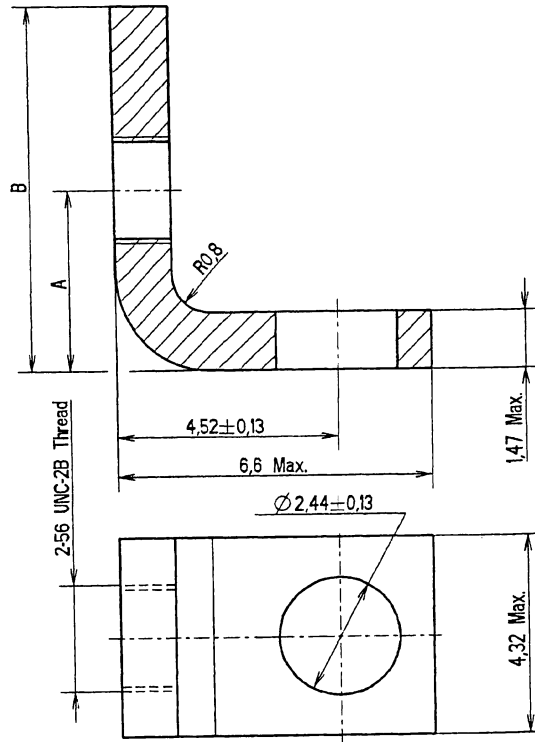

Variant	Sizes	A $\pm 0.13$	B Max
03	9 to 37	3.73	7.82
04	51	4.29	8.89

**NOTES:**

1. All dimensions in mm.
2. Weight:  
 Variant 03 0.42g  
 Variant 04 0.45g
3. Variant 04 is not applicable to MDMA connectors.

Variant 07 - Screw Sub-Assembly

Screw

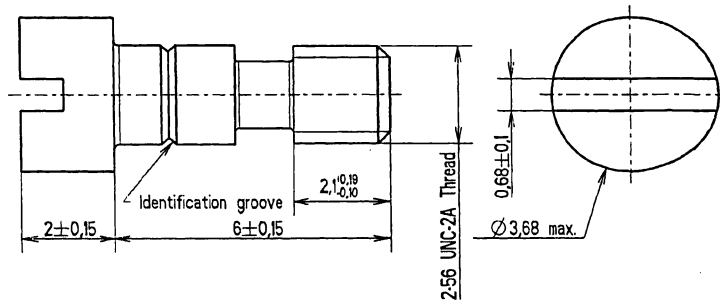

Clip

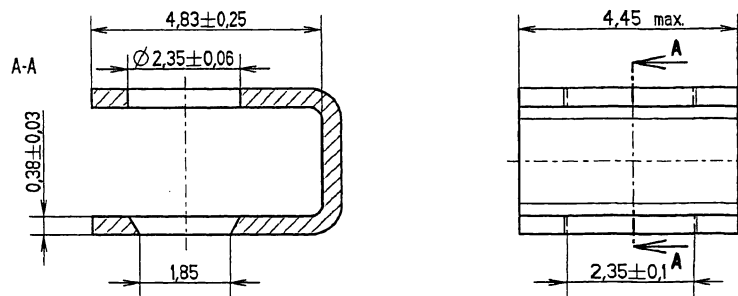

**NOTES:**

1. All dimensions in mm.
2. Weight:  
Screw 0.3g  
Clip 0.14g
- 3.

Torque Values	Min (Nm)	Max (Nm)
Screw	0.28	0.32

Variant 08 - Screwlock Sub-Assembly (Front Panel Mounting)

Screwlock

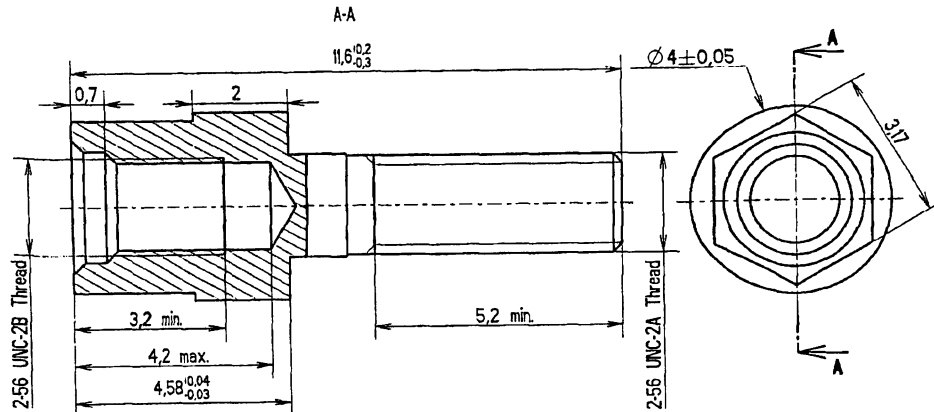

Nut

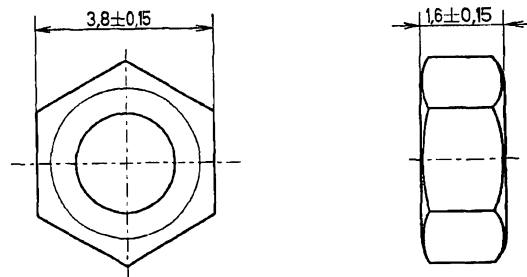

~~Lock-Washer~~

See attached

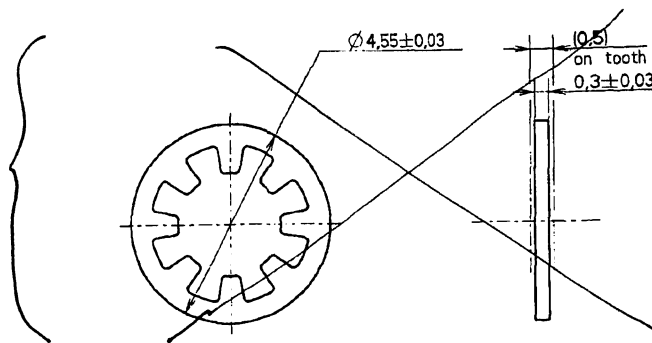

**NOTES:**

1. All dimensions in mm.
2. Weight:  
Screwlock 0.51g  
Nut 0.13g



Lock-Washer 0.02g

3.

Torque Values	Min (Nm)	Max (Nm)
Screwlock male side	0.44	0.48
Screwlock female side	0.28	0.32
Nut	0.44	0.48

Variant 09 - Screwlock Sub-Assembly (Rear Panel Mounting)

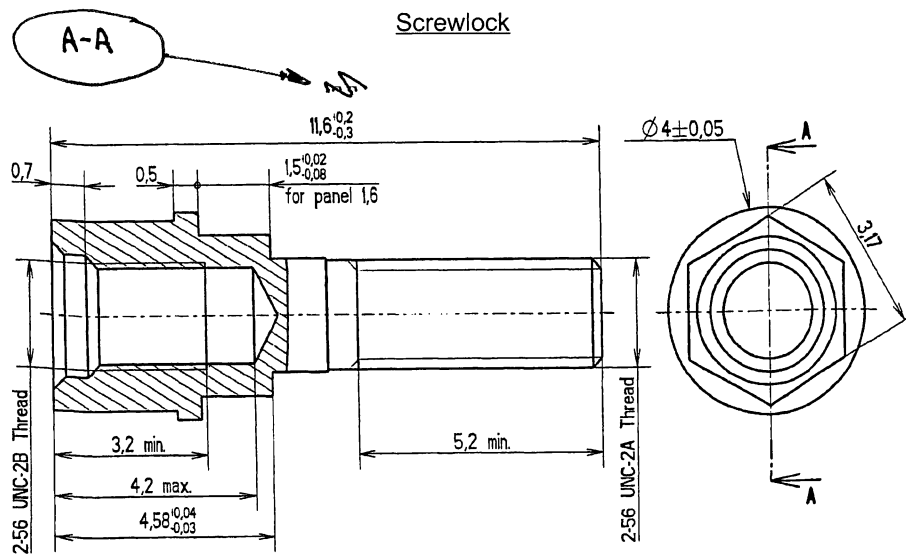

**Nut**

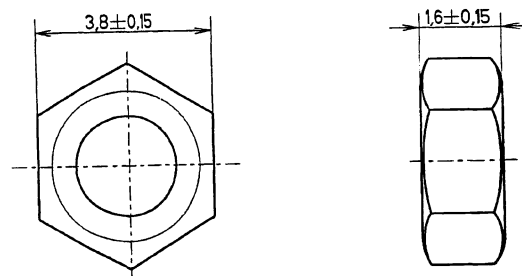

See attached

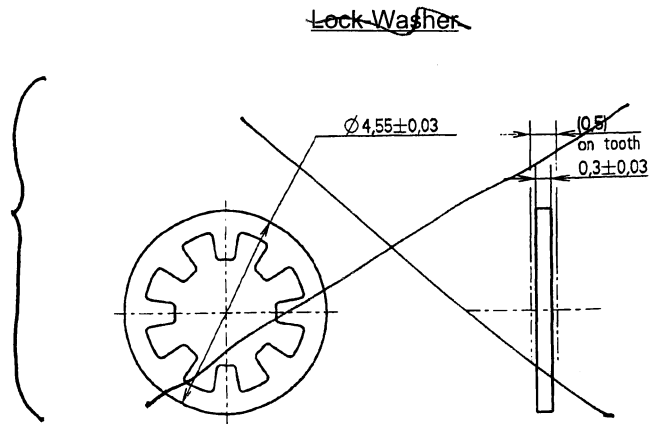

**NOTES:**

1. All dimensions in mm.
2. Weight:  
Screwlock 0.45g  
Nut 0.13g  
Lock-Washer 0.02g
- 3.

Torque Values	Min (Nm)	Max (Nm)
Screwlock male side	0.44	0.48
Screwlock female side	0.28	0.32
Nut	0.44	0.48

Variant 10 - Screwlock Assembly for Connector Savers

Screwlock

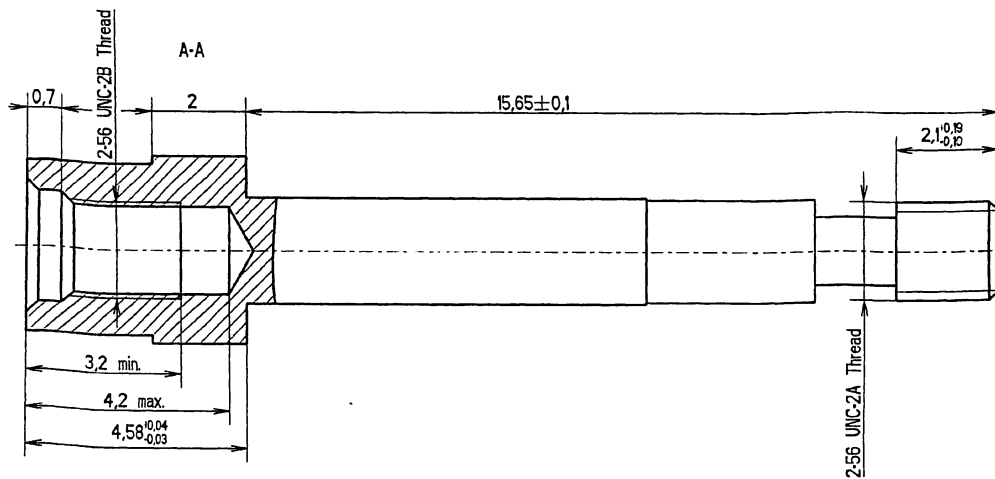

Variant 08 - Screwlock Sub-Assembly (Front Panel Mounting)

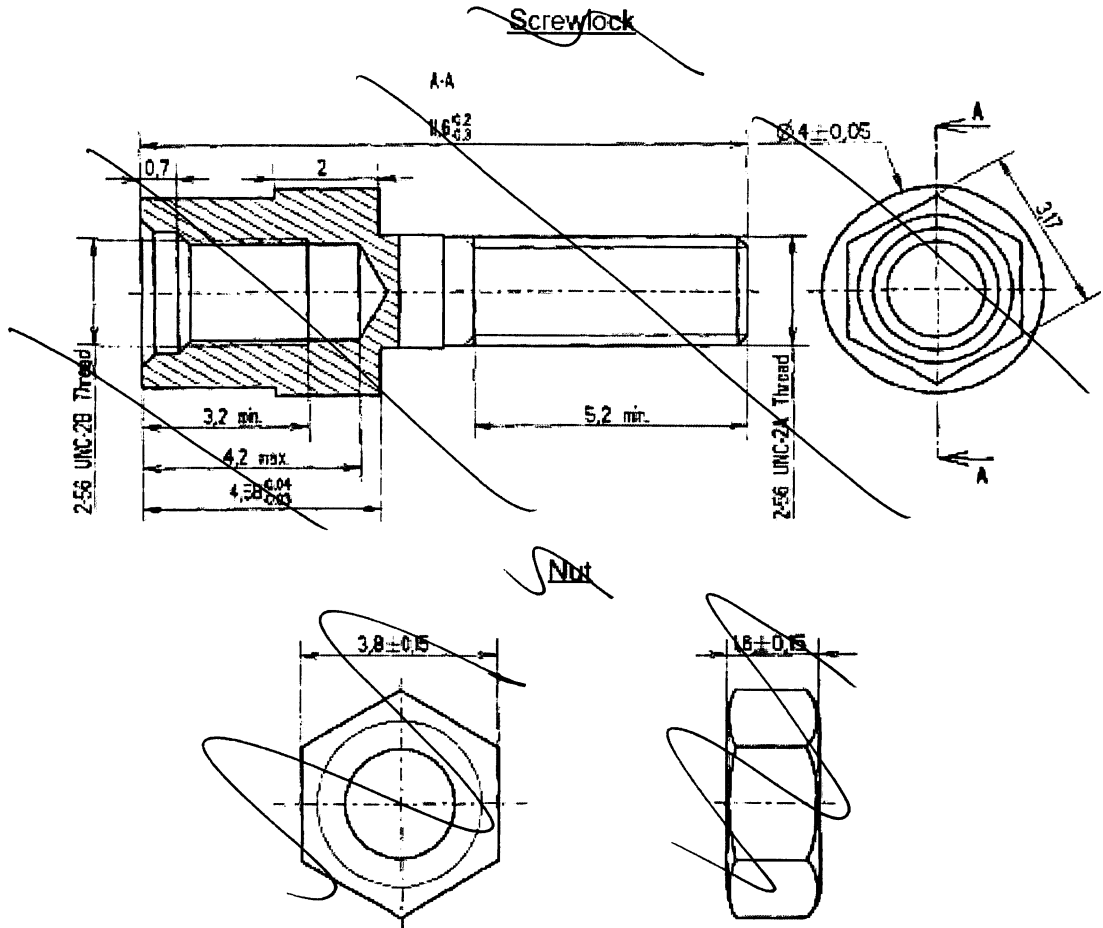

from C & K  
 3401-032A.doc  
 (plus amendments)  
 Variant 08  
 Lock-Washer  
 and  
 Variant 09  
 Lock-washer

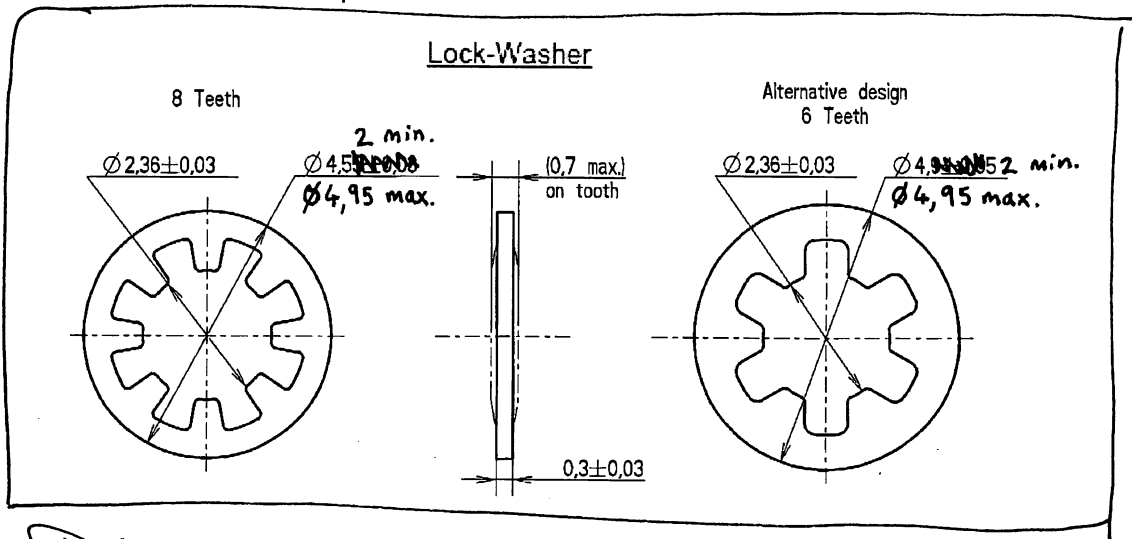

**NOTES:**

1. All dimensions in mm.
2. Weight:  
 Screwlock 0.51g  
 Nut 0.13g

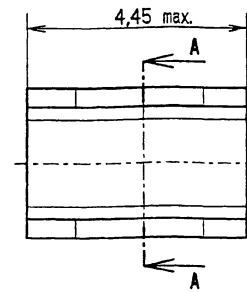
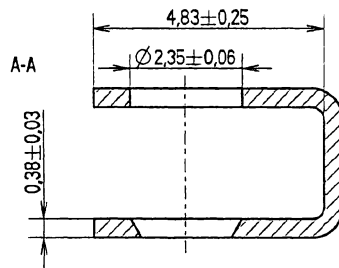
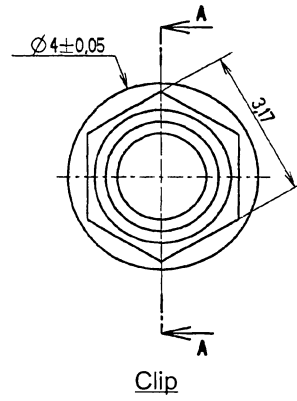

**NOTES:**

1. All dimensions in mm.
2. Weight:  
Screwlock 0.79g  
Clip 0.14g
- 3.

Torque Values	Min (Nm)	Max (Nm)
Screwlock male side	0.36	0.4
Screwlock female side	0.28	0.32

Variant 11 - Screwlock for Connectors FR136/FR139

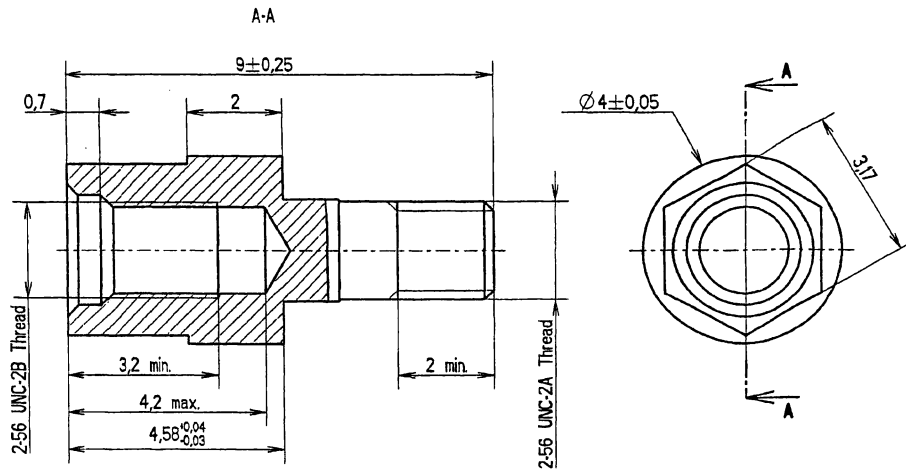

**NOTES:**

1. All dimensions in mm.
2. Weight:  
Screwlock 0.43g
- 3.

Torque Values	Min (Nm)	Max (Nm)
Screwlock male side	0.44	0.48
Screwlock female side	0.28	0.32

→ VARIANTS 12 TO 17 HERE (SEE ATTACHED) ←

**2. APPLICABLE DOCUMENTS**

The following documents form part of this specification and shall be read in conjunction with it:

- ESCC Generic Specification No. 3401, Connectors, Electrical, Circular and Rectangular.
- ESCC Detail Specification No. 3401/029, Connectors, Electrical, Rectangular, Microminiature, based on Type MDM.
- ESCC Detail Specification No. 3401/041, Connector Savers, Electrical, Rectangular, Microminiature, based on type MDM.

**3. TERMS, DEFINITIONS, ABBREVIATIONS, SYMBOLS AND UNITS**

For the purpose of this specification, the terms, definitions, abbreviations, symbols and units specified in ESCC Basic Specification No. 21300 shall apply.

**4. REQUIREMENTS**

**4.1 GENERAL**

The complete requirements for procurement of the accessories specified herein are stated in this

- ESCC Detail Specification No. 3401/077, Connectors, Electrical, Rectangular, Microminiature, Removable Contacts, based on type MDMA.

## Variants 12 to 17 - Interfacial Seals for MDMA Female Connectors

Variant 15 (shell size 25) shown for illustrative purposes

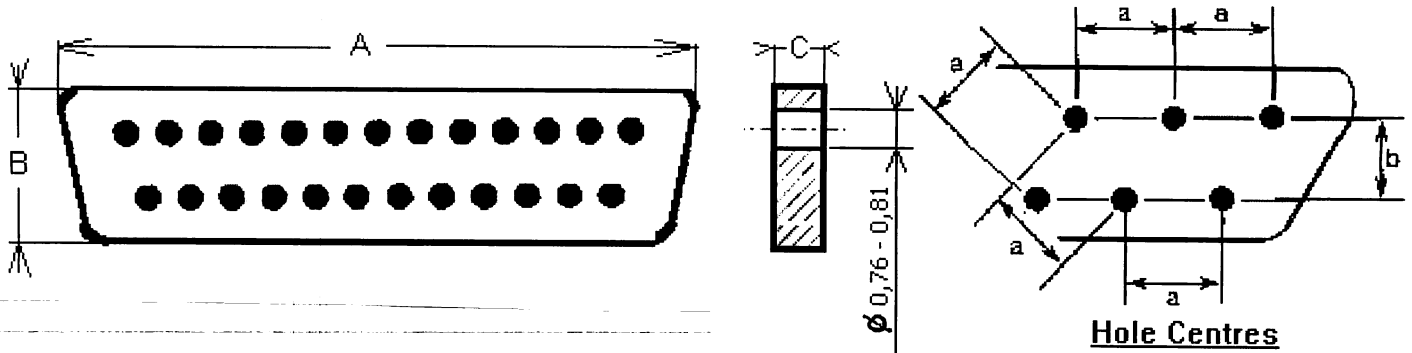

## NOTES :

1.  $a$  = Distance between hole centres : 1.27 mm typical.2.  $b$  = Distance between rows : 1.09 mm typical.(from C&K  
3401-032A.doc)

Variant No.	Shell Size	Dimensions (mm)						Weight Max. (g)
		A		B		C		
		Min.	Max.	Min.	Max.	Min.	Max.	
12	9	8.33	8.73	4.6	4.8	0.6	0.7	0.02
13	15	12.14	12.54	4.6	4.8	0.6	0.7	0.03
14	21	15.95	16.35	4.6	4.8	0.6	0.7	0.04
15	25	18.49	18.89	4.6	4.8	0.6	0.7	0.05
16	31	22.3	22.7	4.6	4.8	0.6	0.7	0.07
17	37	26.11	26.51	4.6	4.8	0.6	0.7	0.08

specification and ESCC Generic Specification No. 3401. Deviations from the Generic Specification, applicable to this specification only, are listed in Para. 4.2.

Deviations from the applicable Generic Specification and this Detail Specification, formally agreed with specific Manufacturers on the basis that the alternative requirements are equivalent to the ESCC requirements and do not affect the components' reliability, are listed in the appendices attached to this specification.

## 4.2 DEVIATIONS FROM GENERIC SPECIFICATION

### 4.2.1 Deviations from Special In-process Controls

None.

### 4.2.2 Deviations from Final Production Tests (Chart II)

~~Para. 9.5.7 External Visual Inspection and Para. 9.4.6, Dimension Check shall be performed. The following details shall apply:~~

~~Magnification to be used for visual inspection shall be X3.~~

~~The other tests are not applicable.~~

Para. to  
be  
re-written,  
see  
attached

### 4.2.3 Deviations from Burn-in and Electrical Measurements (Chart III)

Not applicable.

Chart III is

### 4.2.4 Deviations from Qualification, Environmental and Endurance Tests (Chart IV)

Chart IV is not applicable.

### 4.2.5 Deviations from Lot Acceptance Tests (Chart V)

Chart V is not applicable.

## 4.3 MECHANICAL REQUIREMENTS

### 4.3.1 Dimension Check

The dimensions of the accessories specified herein shall be verified in accordance with the requirements set out in Para. 9.1.1 of ESCC Generic Specification No. 3401 and Para. 4.2.2 of this specification; they shall conform to those shown in Figure 2.

### 4.3.2 Weight

The maximum weight of the accessories specified herein shall be as specified in Figure 2.

### 4.3.3 Torque Value

The torque value to be used for tightening the screws of the accessories specified herein shall be as specified in Table 1.

## 4.4 MATERIALS AND FINISHES

The materials and finishes shall be as specified herein. Where a definite material is not specified, a material which will enable the components specified herein to meet the performance requirements of this specification shall be used. Acceptance or approval of any constituent material does not guarantee

acceptance of the finished product.

#### 4.4.1 Screw Lock Assemblies and Brackets

These shall be made of passivated stainless steel, type 303.

#### 4.5 MARKING

##### 4.5.1 General

The marking of components delivered to this specification shall be in accordance with the requirements of ESCC Basic Specification No. 21700 and the following paragraphs. Each component shall be marked in respect of:-

- (a) The ESCC qualified components symbol (for ESCC qualified components only).
- (b) ~~(b)~~ The ESCC Component Number.
- (c) ~~(c)~~ Traceability Information

These components being too small to accommodate the marking specified above, the ESCC marking information shall accompany the component in its primary package.

##### 4.5.2 The ESCC Component Number

The ESCC Component Number shall be constituted and marked as follows:

340103<sup>3</sup>20XB

- Detail Specification Number: 3401032
- Type Variant (See Figure 2)
- Testing Level

##### 4.5.3 Traceability Information

Traceability information shall be marked in accordance with ESCC Basic Specification No. 21700.

#### 4.6 ELECTRICAL MEASUREMENTS

Not applicable.

#### 4.7 SCREENING TESTS (TABLES 4 AND 5)

Not applicable.

#### 4.8 ENVIRONMENTAL AND ENDURANCE TESTS

Not applicable.

#### 4.4.2 Interfacial Seals

These shall be made of silicon base rubber.



3401/032

4.2.2 Deviations from Final Production Tests (Chart 11)

Only the following tests shall be performed:

Para. 9.6, Dimension Check.

Para. 9.7, External Visual Inspection. The magnification shall be X3.