

MARK-UP FOR DCR 396

S. Marker  
17/07/08.



Pages 1 to 12

**DIODES, POWER RECTIFIER, HIGH EFFICIENCY, FAST  
RECOVERY**

**BASED ON TYPE BYV54-200**

**ESCC Detail Specification No. 5103/031**

\* 4 July 2008

Issue <del>3</del>	April 2007
--------------------	------------

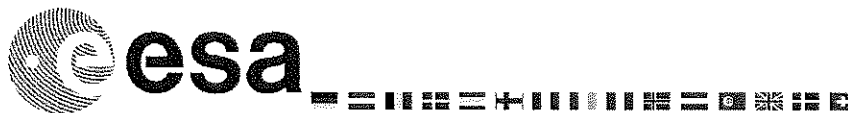

Document Custodian: European Space Agency - see <https://escies.org>



**LEGAL DISCLAIMER AND COPYRIGHT**

European Space Agency, Copyright © <sup>2008</sup>2007. All rights reserved.

The European Space Agency disclaims any liability or responsibility, to any person or entity, with respect to any loss or damage caused, or alleged to be caused, directly or indirectly by the use and application of this ESCC publication.

This publication, without the prior permission of the European Space Agency and provided that it is not used for a commercial purpose, may be:

- copied in whole, in any medium, without alteration or modification.
- copied in part, in any medium, provided that the ESCC document identification, comprising the ESCC symbol, document number and document issue, is removed.



**DOCUMENTATION CHANGE NOTICE**

(Refer to <https://escies.org> for ESCC DCR content)

DCR No.	CHANGE DESCRIPTION
287	Specification up issued to incorporate editorial and technical changes per DCR.

396

\*

**TABLE OF CONTENTS**

<b>1.</b>	<b><u>GENERAL</u></b>	<b><u>5</u></b>
1.1	Scope	5
1.2	Applicable Documents	5
1.3	Terms, Definitions, Abbreviations, Symbols and Units	5
1.4	The ESCC Component Number and Component Type Variants	5
1.4.1	The ESCC Component Number	5
1.4.2	Component Type Variants	5
1.5	Maximum Ratings	5
1.6	Handling Precautions	6
1.7	Physical Dimensions and Terminal Identification	6
1.8	Functional Diagram	7
1.9	Materials and Finishes	7
<b>2.</b>	<b><u>REQUIREMENTS</u></b>	<b><u>8</u></b>
2.1	General	8
2.1.1	Deviations from the Generic Specification	8
2.1.1.1	Deviations from Qualification and Periodic Tests - Chart F4	8
2.2	Marking	8
2.3	Terminal Strength	8
2.4	Electrical Measurements at Room, High and Low Temperatures	8
2.4.1	Room Temperature Electrical Measurements	8
2.4.2	High and Low Temperatures Electrical Measurements	9
2.4.3	Notes to Electrical Measurement Tables	9
2.5	Parameter Drift Values	10
2.6	Intermediate and End-Point Electrical Measurements	10
2.7	High Temperature Reverse Bias Burn-in Conditions	10
2.8	Power Burn-in Conditions	11
2.9	Operating Life Conditions	11
	APPENDIX 'A'	12



**1. GENERAL**

**1.1 SCOPE**

This specification details the ratings, physical and electrical characteristics and test and inspection data for the component type variants and/or the range of components specified below. It supplements the requirements of, and shall be read in conjunction with, the ESCC Generic Specification listed under Applicable Documents.

**1.2 APPLICABLE DOCUMENTS**

The following documents form part of this specification and shall be read in conjunction with it:

- (a) ESCC Generic Specification No. 5000
- (b) MIL-STD-750, Test Methods and Procedures for Semiconductor Devices

**1.3 TERMS, DEFINITIONS, ABBREVIATIONS, SYMBOLS AND UNITS**

For the purpose of this specification, the terms, definitions, abbreviations, symbols and units specified in ESCC Basic Specification No. 21300 shall apply.

**1.4 THE ESCC COMPONENT NUMBER AND COMPONENT TYPE VARIANTS**

**1.4.1 The ESCC Component Number**

The ESCC Component Number shall be constituted as follows:

Example: 510303101

- Detail Specification Reference: 5103031
- Component Type Variant Number: 01 (as required)

**1.4.2 Component Type Variants**

The component type variants applicable to this specification are as follows:

Variant Number	Based on Type	Case	Description	Lead Material and Finish	Weight max g
01	BYV54-200	TO-254	Single diode	H9	10

\*  
(Add variants 02 to 05 see attached)

→ The lead material and finish shall be in accordance with the requirements of ESCC Basic Specification No. 23500.

**1.5 MAXIMUM RATINGS**

The maximum ratings shall not be exceeded at any time during use or storage.

Maximum ratings shall only be exceeded during testing to the extent specified in this specification and when stipulated in Test Methods and Procedures of the ESCC Generic Specification.

Characteristics	Symbols	Maximum Ratings	Unit	Remarks
Forward Surge Current	$I_{FSM}$	400	A	Note 1
Repetitive Peak Reverse Voltage	$V_{RRM}$	200	V	Note 2

**Thacker, Steve**

---

\*

Para 1.4.2 Component Type Variants

Variant Number	Based on Type	Case	Description	Lead Material and Finish	Weight Max g
01	BYV54-200	TO-254	Single diode	H9	10
02	BYV54-200	TO-254	Single diode	H14	10
03	BYV54-200	TO-254	Single diode	H4	10
04	BYV54-200	TO-254AA	Single diode-Low Ohmic Package	S14	10
05	BYV54-200	TO-254AA	Single diode-Low Ohmic Package	S4	10

Characteristics	Symbols	Maximum Ratings	Unit	Remarks
Average Output Rectified Current	$I_O$	40	A	50% Duty Cycle Note 3
RMS Forward Current	$I_{F(rms)}$	60	A	
Operating Temperature Range (Case Temperature)	$T_{op}$	-55 to +150	°C	Note 4
Junction Temperature	$T_j$	+150	°C	
Storage Temperature Range	$T_{stg}$	-55 to +150	°C	Note 4
Soldering Temperature	$T_{sol}$	+260	°C	Note 5
Thermal Resistance, Junction to Case	$R_{th(j-c)}$	1	°C/W	Note 6

**NOTES:**

- Sinusoidal pulse of 10ms duration.
- Pulsed, duration 5ms,  $f = 50\text{Hz}$ .
- At  $T_{case} > +110^\circ\text{C}$ , derate linearly to 0A at  $+150^\circ\text{C}$ . for Variants 01, 02, 03  
 At  $T_{case} > +99^\circ\text{C}$ , derate linearly to 0A at  $+150^\circ\text{C}$ . for Variants 04, 05
- For Variants with hot solder dip lead finish, all testing performed at  $T_{amb} > +125^\circ\text{C}$  shall be carried out in a 100% inert atmosphere.
- Duration 10 seconds maximum at a distance of not less than 1.5mm from the device body and the same lead shall not be resoldered until 3 minutes have elapsed.
- Package mounted on an infinite heatsink.

\*  
\*  
01, 03, 05,

and TO-254AA packages

1.6 **HANDLING PRECAUTIONS**

The TO-254 package contains Beryllium Oxide (BeO) and therefore must not be ground, machined, sandblasted or subjected to any mechanical operation which will produce dust. The case must not be subjected to any chemical process (e.g. etching) which will produce fumes.

1.7 **PHYSICAL DIMENSIONS AND TERMINAL IDENTIFICATION**

Metal Flange Mount Package (TO-254) - 3 lead

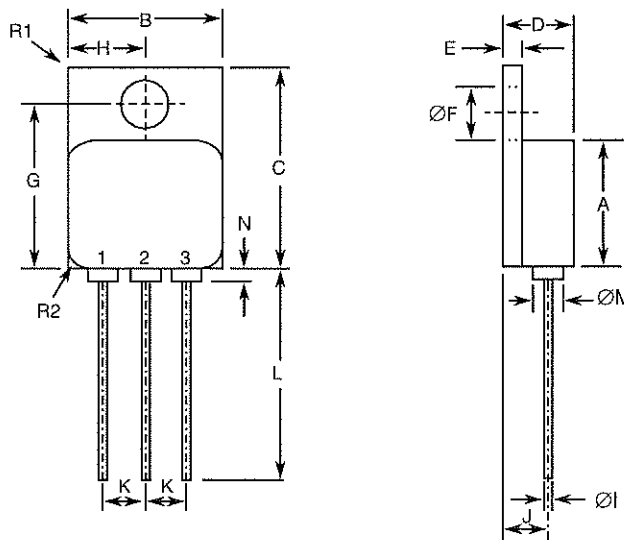

Symbols	Dimensions mm		Notes
	Min	Max	
A	13.59	13.84	
B	13.59	13.84	
C	20.07	20.32	
D	6.3	6.7	
E	1	1.35	
ØF	3.5	3.9	
G	16.89	17.4	
H	6.86 BSC		
ØI	0.89	1.14	2
J	3.81 BSC		
K	3.81 BSC		
L	12.95	14.5	
ØM	3.05 Typical		2
N	-	0.71	2
R1	-	1	3
R2	1.65 Typical		4

**NOTES:**

1. The terminal identification is specified by the components geometry. See Functional Diagram for the terminal connections.
2. 3 places.
3. Radius of heatsink flange corner, 4 places.
4. Radius of body corner, 4 places.

1.8

FUNCTIONAL DIAGRAM

*Variants 01, 02, 03*

Terminal 1: Cathode  
Terminal 2: Not connected  
Terminal 3: Anode

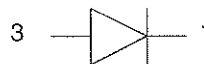

*\* Add new figure - see attached )*

**NOTES:**

1. The case is not connected to any lead.

1.9

MATERIALS AND FINISHES

Materials and finishes shall be as follows:

- a) Case  
The case shall be hermetically sealed and have a metal body. The leads pass through ceramic eyelets brazed into the frame and the lid shall be welded.



Para 1.8

\*

Terminal 1: Cathode  
Terminal 2: Anode  
Terminal 3: Anode

Variants 04,05

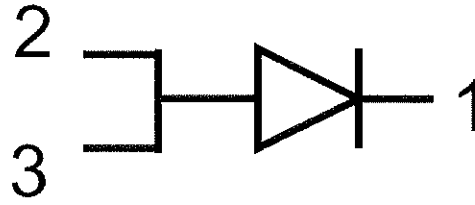

- b) Leads  
As specified in Component Type Variants.

## 2. REQUIREMENTS

### 2.1 GENERAL

The complete requirements for procurement of the components specified herein are as stated in this specification and the ESCC Generic Specification. Permitted deviations from the Generic Specification, applicable to this specification only, are listed below.

Permitted deviations from the Generic Specification and this Detail Specification, formally agreed with specific Manufacturers on the basis that the alternative requirements are equivalent to the ESCC requirement and do not affect the component's reliability, are listed in the appendices attached to this specification.

#### 2.1.1 Deviations from the Generic Specification

##### 2.1.1.1 *Deviations from Qualification and Periodic Tests - Chart F4*

- (a) Constant Acceleration is not applicable.

### 2.2 MARKING

The marking shall be in accordance with the requirements of ESCC Basic Specification No. 21700 and as follows.

The information to be marked on the component shall be:

- (a) The ESCC qualified components symbol (for ESCC qualified components only).
- (b) The ESCC Component Number.
- (c) Traceability information.
- (d) Warning sign for Beryllium Oxide.

### 2.3 TERMINAL STRENGTH

The test conditions for Terminal Strength, tested as specified in the ESCC Generic Specification, shall be as follows:

Test Condition: A, tension, with an applied force of 10N for a duration of 10s.

### 2.4 ELECTRICAL MEASUREMENTS AT ROOM, HIGH AND LOW TEMPERATURES

Electrical measurements shall be performed at room, high and low temperatures.  
Consolidated notes are given after the Tables.

#### 2.4.1 Room Temperature Electrical Measurements

The measurements shall be performed at  $T_{amb}=+22 \pm 3^{\circ}\text{C}$ .

Characteristics	Symbols	MIL-STD-750 Test Method	Test Conditions (Note 1)	Limits		Units
				Min	Max	
Reverse Current	$I_R$	4016	DC Method $V_R = 200V$	-	50	$\mu A$
Forward Voltage	$V_{F1}$	4011	Pulse Method $I_F = 20A$ , Note 2	-	1.1 0.95	V
	$V_{F2}$	4011	Pulse Method $I_F = 30A$ , Note 2	-	1.3 1.1	V
Breakdown Voltage	$V_{(BR)}$	4021	$I_R = 100\mu A$	200	-	V
Capacitance	C	4001	$V_R = 10V$ $f = 1MHz$	-	400	pF
Reverse Recovery Time	$t_{rr}$	4031	Test Condition A $I_F = 1A$ $V_R = 30V$ $di_F/dt = -50A/\mu s$	-	60	ns
Thermal Impedance, Junction to Case	$Z_{th(j-c)}$	3101	$I_H = 15V$ to 40A $t_H = 50ms$ $I_M = 50mA$ $t_{md} = 100\mu s$ Note 3	(Calculate $\Delta V_F$ , see Note 3) 4		$^{\circ}C/W$

\*  
\* (see changes as attached)

\*  
\*

2.4.2 High and Low Temperatures Electrical Measurements

Characteristics	Symbols	MIL-STD-750 Test Method	Test Conditions (Notes 1, 5)	Limits		Units
				Min	Max	
Reverse Current	$I_R$	4016	$T_{case} = +125(+0 -5)^{\circ}C$ DC Method $V_R = 200V$	-	40	mA
Forward Voltage	$V_{F1}$	4011	$T_{case} = +125(+0 -5)^{\circ}C$ Pulse Method $I_F = 20A$ , Note 2	-	1 0.85	V
			$T_{case} = -55(+5 -0)^{\circ}C$ Pulse Method $I_F = 20A$ , Note 2	-	1.3 1.15	V
	$V_{F2}$	4011	$T_{case} = +125(+0 -5)^{\circ}C$ Pulse Method $I_F = 30A$ , Note 2	-	1.1 1	V

\* (see changes as attached)

2.4.3 Notes to Electrical Measurement Tables

- 2 1. Pulsed Width  $\leq 300\mu s$ , Duty Cycle  $\leq 2\%$ .
- 3 2. Performed only during Screening Tests Parameter Drift Values (Initial Measurements), go-no-go.
- 4 3. The limits for  $\Delta V_F$  shall be defined by the manufacturer on every lot in accordance with MIL-STD-750 Method 3101 and shall guarantee the  $R_{th(j-c)}$  limits specified in Maximum Ratings.
- 5 4. Read and record measurements shall be performed on a sample of 5 components with 0 failures
- 1. For Variants 04, 05 testing shall be performed with both anode terminals 2 and 3 tied together

\*  
\*  
\*  
\*  
\*

Thacker, Steve

**Para 2.4.1 Room Temperature Electrical Measurements**

Characteristics	Symbols	MIL-STD-750 Test Method	Test Conditions (Note 1)	Limits		Units
				Min	Max	
Forward Voltage 1	V <sub>F1</sub>	4011	Pulse Method I <sub>F</sub> = 20 A, Note 2 Variants 01, 02, 03 Variants 04, 05	-	1.1 0.95	V
Forward Voltage 2	V <sub>F2</sub>	4011	Pulse Method I <sub>F</sub> = 30 A, Note 2 Variant 01 to 03 Variant 04 and 05	-	1.3 1.1	V

**Para 2.4.2 High and Low Temperature Electrical Measurements**

Characteristics	Symbols	MIL-STD-750 Test Method	Test Conditions (Notes 1, 5)	Limits		Units
				Min	Max	
Forward Voltage 1	V <sub>F1</sub>	4011	T <sub>case</sub> = +125(+0 -5)°C Pulse Method I <sub>F</sub> = 20 A, Note 2 Variants 01, 02, 03 Variants 04, 05	-	1 0.85	V
			T <sub>case</sub> = -55(+5 -0)°C Pulse Method I <sub>F</sub> = 20 A, Note 2 Variants 01, 02, 03 Variants 04, 05		1.3 1.15	V
Forward Voltage 2	V <sub>F2</sub>	4011	T <sub>case</sub> = +125(+0 -5)°C Pulse Method I <sub>F</sub> = 30 A, Note 2 Variants 01, 02, 03 Variants 04, 05	-	1.1 1	V

allowed. Alternatively a 100% inspection may be performed.

2.5 PARAMETER DRIFT VALUES

Unless otherwise specified, the measurements shall be performed at  $T_{amb}=+22 \pm 3^{\circ}C$ .

The test methods and test conditions shall be as per the corresponding test defined in Room Temperature Electrical Measurements.

The drift values ( $\Delta$ ) shall not be exceeded for each characteristic specified. The corresponding absolute limit values for each characteristic shall not be exceeded.

Characteristics	Symbols	Limits			Units
		Drift Value $\Delta$	Absolute		
			Min	Max	
Reverse Current	$I_R$	$\pm 6$ or (1) $\pm 100\%$	-	50	$\mu A$
Forward Voltage 1	$V_{F1}$	$\pm 0.07$	-	1.1	V

\* see changes as attached

\*

**NOTES:**

1. Whichever is the greater referred to the initial value.

0.95

2.6 INTERMEDIATE AND END-POINT ELECTRICAL MEASUREMENTS

Unless otherwise specified, the measurements shall be performed at  $T_{amb}=+22 \pm 3^{\circ}C$ .

The test methods and test conditions shall be as per the corresponding test defined in Room Temperature Electrical Measurements . The limit values for each characteristic shall not be exceeded.

Characteristics	Symbols	Limits		Units
		Min	Max	
Reverse Current	$I_R$	-	50	$\mu A$
Forward Voltage 1	$V_{F1}$	-	*	V
	$V_{F2}$	*	*	*

\* (see changes attached)

Add  $V_{F2}$

2.7 HIGH TEMPERATURE REVERSE BIAS BURN-IN CONDITIONS

Characteristics	Symbols	Limits	Units
Ambient Temperature	$T_{amb}$	+150 (+0 -5)	$^{\circ}C$
Reverse Voltage	$V_R$	160	V
Duration	t	$\geq 48$	hours

**NOTES:**

1. For variants 04, 05 testing shall be performed with both anode terminals 2 and 3 tied together.

Thacker, Steve

Para 2.5 PARAMETER DRIFT VALUES

Characteristics	Symbols	Limits		Units	
		Drift Value $\Delta$	Absolute		
			Min		Max
Forward Voltage 1 Variants 01, 02, 03 Variants 04, 05	V <sub>F1</sub>	$\pm 0.07$	-	1.1 0.95	V

Para 2.6 INTERMEDIATE AND END-POINT ELECTRICAL MEASUREMENTS

Characteristics	Symbols	Limits		Units
		Min	Max	
Forward Voltage 1 Variants 01, 02, 03 Variants 04, 05	V <sub>F1</sub>	-	1.1 0.95	V
Forward Voltage 2 Variants 01, 02, 03 Variants 04, 05	V <sub>F2</sub>	-	1.3 1.1	V

2.8 POWER BURN-IN CONDITIONS

Characteristics	Symbols	Test Conditions	Units
Case Temperature	$T_{case}$	+125 ±15, Note 1	°C
Junction Temperature	$T_j$	+150 (+0 -5)	°C
Average Output Rectified Current	$I_O$	≥ 10, Note 1	A

**NOTES:**

1. The case temperature and/or output current may be adjusted, within their given limit ranges, to attain the specified junction temperature.
2. For Variants 04, 05 testing shall be performed with both anode terminals 2 and 3 tied together.

2.9 OPERATING LIFE CONDITIONS

The conditions shall be as specified for Power Burn-in.



**APPENDIX 'A'**

**AGREED DEVIATIONS FOR STMICROELECTRONICS (F)**

ITEMS AFFECTED	DESCRIPTION OF DEVIATIONS
Deviations from Production Control- Chart F2	Special In-process Control Internal Visual Inspection. Wedge bonds equal to 1.1 wire diameters are acceptable for bonding with a V-Groove tool.